



12-2008

# MOTORREDUCTORI ROSSI

(«Lange» und normale) STIRNRAD- UND  
KEGELSTIRNRADGETRIEBE UND GETRIEBEMOTOREN  
PARALLEL (standard and «long») AND RIGHT ANGLE  
SHAFT GEAR REDUCERS AND GEARMOTORS

$P_1$  0,09 ... 160 kW,  $M_{N2} \leq 7\ 100$  daN m,  $i_N$  2,5 ... 12\ 500,  $n_2$  0,071 ... 224 min<sup>-1</sup>

## G05



## Inhalt

1 - Zeichen und Maßeinheiten	6
2 - Eigenschaften	8
3 - Bezeichnung	16
4 - Wärmeleistung $P_t$	17
5 - Betriebsfaktor $f_s$	18
6 - Auswahl	22
7 - Nennleistungen und Nenndrehmomente <b>(Stirnradgetriebe)</b>	25
8 - Bauarten, Abmessungen, Bauformen und Ölmengen	36
9 - Nennleistungen und Nenndrehmomente <b>(Kegelstirnradgetriebe)</b>	41
10 - Bauarten, Abmessungen, Bauformen und Ölmengen	55
11 - Herstellungsprogramm <b>(Stirnradtriebemoto- ren)</b>	59
12 - Herstellungsprogramm <b>(Stirnradtriebemoto- ren für Fahrtriebe)</b>	74
13 - Bauarten, Abmessungen, Bauformen und Ölmengen	83
14 - Herstellungsprogramm <b>(Kegelstirnradgetriebe- motoren)</b>	92
15 - Herstellungsprogramm <b>(Kegelstirnradgetriebe- motoren für Fahrtriebe)</b>	110
16 - Bauarten, Abmessungen, Bauformen und Ölmengen	119
17 - Kombieinheiten Getriebemotoren	126
18 - Radialbelastungen $F_{r1}$ auf dem schnelllaufen- den Wellenende	130
19 - Radial- $F_{r2}$ oder Axialbelastungen $F_{a2}$ auf dem langsamlaufenden Wellenende	130
20 - Bau- und Betriebsdetails	148
21 - Aufstellung und Wartung	154
22 - Zubehör und Sonderausführungen (inkl. Ausführ. für Rührwerke, Extruder, ⚠ ATEX)	161
23 - Technische Formeln	179

## Index

1 - Symbols and units of measure	6
2 - Specifications	8
3 - Designation	16
4 - Thermal power $P_t$	17
5 - Service factor $f_s$	18
6 - Selection	22
7 - Nominal powers and torques <b>(parallel shaft gear reducers)</b>	25
8 - Designs, dimensions, mounting positions and oil quantities	36
9 - Nominal powers and torques <b>(right angle shaft gear reducers)</b>	41
10 - Designs, dimensions, mounting positions and oil quantities	55
11 - Manufacturing programme <b>(parallel shaft gearmotors)</b>	59
12 - Manufacturing programme <b>(parallel shaft gearmotors for traverse movements)</b>	74
13 - Designs, dimensions, mounting positions and oil quantities	83
14 - Manufacturing programme <b>(right angle shaft gearmotors)</b>	92
15 - Manufacturing programme <b>(right angle shaft gearmotors for traverse movements)</b>	110
16 - Designs, dimensions, mounting positions and oil quantities	119
17 - Combined gearmotor units	126
18 - Radial loads $F_{r1}$ on high speed shaft end	130
19 - Radial loads $F_{r2}$ or axial loads $F_{a2}$ on low speed shaft end	130
20 - Structural and operational details	148
21 - Installation and maintenance	154
22 - Accessories and non-standard designs (designs for agitators, extruders, ⚠ ATEX, included)	161
23 - Technical formulae	179

## Stirnradgetriebe und -getriebemotoren

## Parallel shaft gear reducers and gearmotors

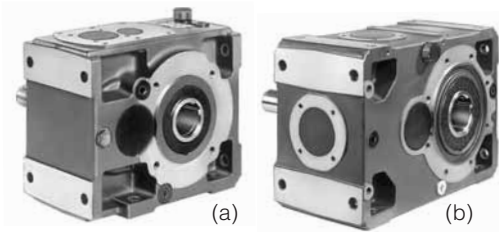

**I 63 ... 100 (a)**  
**I 125 ... 360 (b)**  
 mit 1 Stirnradpaar  
 with 1 cylindrical gear pair



**2I 40\* ... 125**  
 mit 2 Stirnradpaaren  
 with 2 cylindrical gear pairs

**4I\* 63 ... 125**  
 mit 4 Stirnradpaaren  
 with 4 cylindrical gear pairs

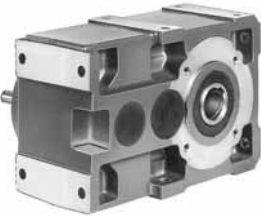

**3I 40\*, 50\* ... 125**  
 mit 3 Stirnradpaaren  
 with 3 cylindrical gear pairs



**2I, 3I 140 ... 360**  
 mit 2, 3 Stirnradpaaren  
 with 2, 3 cylindrical gear pairs



## «Lange» Serie (Patentanmeldung)

## «Long» series (patent pending)

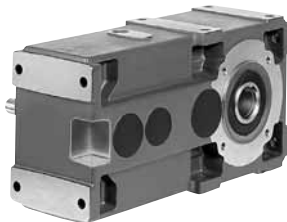

**2I, 3I\* 100, 125**  
 mit 2, 3 Stirnradpaaren  
 und 1 Zwischenrad  
 with 2, 3 cylindrical gear pairs  
 and 1 idle gear



**2I, 3I 140 ... 360\*\***  
 mit 2, 3 Stirnradpaaren  
 und 1 Zwischenrad  
 with 2, 3 cylindrical gear pairs  
 and 1 idle gear



## Kombieinheiten Getriebemotoren

## Combined gearmotors units

**63 ... 125**

**140 ... 360**



Stirnradtyp mit 2, 3 Stirnradpaaren gepaart mit Stirnradtyp (koaxiale Wellenanordnung) mit 2, 3 Stirnradpaaren  
 parallel shaft type with 2, 3 cylindrical gear pairs coupled with coaxial type having 2, 3 cylindrical gear pairs

\* nur Getriebemotoren  
 \*\* MR 2I, 3I 250 ... 360, auf Anfrage

\* gearmotors only  
 \*\* MR 2I, 3I 250 ... 360, on request

## Kegelstirnradgetriebe und Kegelstirnrad- getriebemotoren

## Right angle shaft gear reducers and gear- motors



**CI 40\* ... 100**  
mit 1 Kegelrad- und 1 Stirnradpaar  
with 1 bevel and 1 cylindrical gear pair

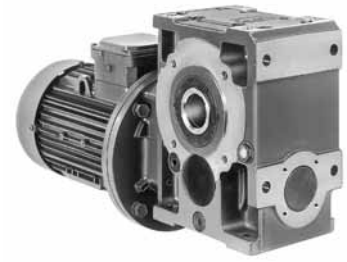

**C3I\* 50 ... 125**  
mit 1 Kegelrad- und 3 Stirnradpaaren  
with 1 bevel and 3 cylindrical gear pairs



**ICI 40\* ... 200**  
mit 1 Kegelrad- und 2 Stirnradpaaren  
with 1 bevel and 2 cylindrical gear pairs

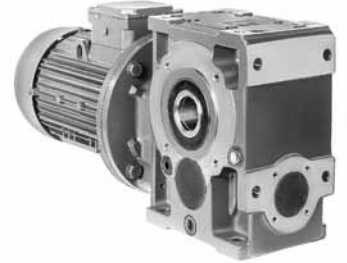

**CI 125 ... 360**  
mit 1 Kegelrad- und 1 Stirnradpaar  
with 1 bevel and 1 cylindrical gear pair



**C2I 140 ... 360**  
mit 1 Kegelrad- und 2 Stirnradpaaren  
with 1 bevel and 2 cylindrical gear pairs

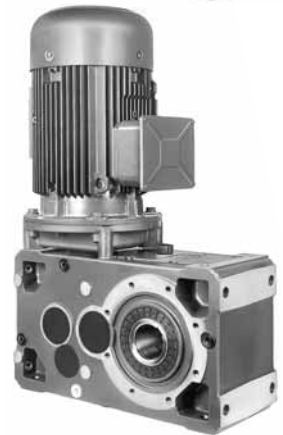

## Kombieinheiten Getriebemotoren

63 ... 200



## Combined gearmotors units

140 ... 360

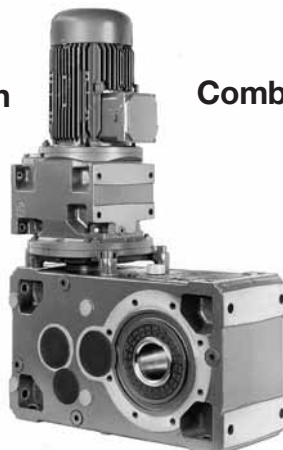

Kegelstirnradtyp mit 1 Kegelrad- und 2 Stirnradpaaren gepaart mit Stirnradtyp (koaxiale Wellenanordnung) mit 2, 3 Stirnradpaaren  
right angle shaft type with 1 bevel and 2 cylindrical gear pairs coupled with coaxial type having 2, 3 cylindrical gear pairs

**Ausführung für Rührwerke, Belüfter, Ventilatoren**

**Design for agitators, aerators, fans**



2I, 3I 125 ... 360



CI, C2I 125 ... 360

**Ausführung für Extruder**

**Design for extruders**



2I, 3I 125 ... 360



CI 125 ... 280  
C2I 140 ... 360

**Getriebemotoren für Fahrtriebe**

**Gearmotors for traverse movements**

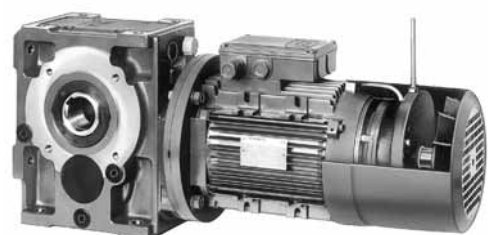

# 1 - Zeichen und Maßeinheiten

# 1 - Symbols and units of measure

Alphabetisch geordnete Zeichen mit entsprechenden Maßeinheiten (im Katalog und in den Formeln angewandt).

Symbols used in the catalogue and formulae, in alphabetical order, with relevant units of measure.

Symbol Symbol	Benennung Definition	Maßeinheit Units of measure			Anmerkungen Notes
		Im Katalog In the catalogue	In den Formeln In the formulae		
			Technisches Maßsystem Technical System	Maßsystem SI <sup>1)</sup> SI <sup>1)</sup> System	
	Abmessungen, Maße	dimensions	mm	–	
<i>a</i>	Beschleunigung	acceleration	–	m/s <sup>2</sup>	
<i>d</i>	Durchmesser	diameter	–	m	
<i>f</i>	Frequenz	frequency	Hz	Hz	
<i>f<sub>s</sub></i>	Betriebsfaktor	service factor			
<i>f<sub>t</sub></i>	Wärmefaktor	thermal factor			
<i>F</i>	Kraft	force	–	kgf   N <sup>2)</sup>	1 kgf ≈ 9,81 N ≈ 0,981 daN
<i>F<sub>r</sub></i>	Radialbelastung	radial load	daN	–	
<i>F<sub>a</sub></i>	Axialbelastung	axial load	daN	–	
<i>g</i>	Fallbeschleunigung	acceleration of gravity	–	m/s <sup>2</sup>	norm. Wert 9,81 m/s <sup>2</sup> normal value 9,81 m/s <sup>2</sup>
<i>G</i>	Gewicht (Gewichtskraft)	weight (weight force)	–	kgf   N	
<i>Gd<sup>2</sup></i>	Schwungmoment	dynamic moment	–	kgf m <sup>2</sup>   –	
<i>i</i>	Übersetzung	transmission ratio			$i = \frac{n_1}{n_2}$
<i>I</i>	Stromstärke	electric current	–	A	
<i>J</i>	Massenträgheitsmoment	moment of inertia	kg m <sup>2</sup>	–   kg m <sup>2</sup>	
<i>L<sub>h</sub></i>	Lagerlebensdauer	bearing life	h	–	
<i>m</i>	Masse	mass	kg	kgf s <sup>2</sup> /m   kg <sup>3)</sup>	
<i>M</i>	Drehmoment	torque	daN m	kgf m   N m	1 kgf m ≈ 9,81 N m ≈ 0,981 daN m
<i>n</i>	Drehzahl	speed	min <sup>-1</sup>	U/min rev/min   –	1 min <sup>-1</sup> ≈ 0,105 rad/s
<i>P</i>	Leistung	power	kW	CV   W	1 CV ≈ 736 W ≈ 0,736 kW
<i>P<sub>t</sub></i>	Wärmeleistung	thermal power	kW	–	
<i>r</i>	Radius	radius	–	m	
<i>R</i>	Verstellbereich	variation ratio			$R = \frac{n_{2 \max}}{n_{2 \min}}$
<i>s</i>	Weg	distance	–	m	
<i>t</i>	Celsius-Temperatur	Celsius temperature	°C	–	
<i>t</i>	Zeit	time	s min h d	s	1 min = 60 s 1 h = 60 min = 3 600 s 1 d = 24 h = 86 400 s
<i>U</i>	Spannung	voltage	V	V	
<i>v</i>	Geschwindigkeit	velocity	–	m/s	
<i>W</i>	Arbeit, Energie	work, energy	MJ	kgf m   J <sup>4)</sup>	
<i>z</i>	Schalzhäufigkeit	frequency of starting	Anl./h starts/h	–	
<i>α</i>	Winkelbeschleunigung	angular acceleration	–	rad/s <sup>2</sup>	
<i>η</i>	Wirkungsgrad	efficiency			
<i>η<sub>s</sub></i>	statischer Wirkungsgrad	static efficiency			
<i>μ</i>	Reibungszahl	friction coefficient			
<i>φ</i>	Ebener Winkel	plane angle	°	rad	1 giro = 2 π rad    1 rev = 2 π rad 1° = $\frac{\pi}{180}$ rad
<i>ω</i>	Winkelgeschwindigkeit	angular velocity	–	–   rad/s	1 rad/s ≈ 9,55 min <sup>-1</sup>

Zusätzliche Indizes und weitere Zeichen

Additional indexes and other signs

Ind.	Benennung	Definition
max	Maximum	maximum
min	Minimum	minimum
N	Nennwert	nominal
1	bezogen auf schnellauf. Welle (Antrieb)	relating to high speed shaft (input)
2	bezogen auf langsamlauf. Welle (Abtrieb)	relating to low speed shaft (output)
÷	von ... bis	from ... to
≈	ungefähr gleich	approximately equal to
≥	größer als oder gleich	greater than or equal to
≤	kleiner als oder gleich	less than or equal to

1) SI ist das Zeichen des Internationalen Einheitensystems, das von der Allgemeinen Konferenz der Gewichte und Maßeinheiten als einheitliches Maßsystem bestimmt und genehmigt wurde.  
S. CNR UNI 10 003-84 (DIN 1 301-93 NF X 02.004, BS 5 555-93, ISO 1 000-92).  
UNI: Ente Nazionale Italiano di Unificazione.  
DIN: Deutscher Normenausschuss (DNA).  
NF: Association Française de Normalisation (AFNOR).  
BS: British Standards Institution (BSI).  
ISO: International Organization for Standardization.

2) Das Newton [N] ist die Kraft, die bei einem Körper Masse 1 kg eine Beschleunigung von 1 m/s<sup>2</sup> verursacht.

3) Das Kilogramm [kg] ist die Masse des in Sèvres gewahrten Prototyps (d.h. 1 dm<sup>3</sup> destilliertes Wasser bei 4 °C).

4) Das Joule [J] ist die Arbeit der Kraft 1 N bei einer Bewegung von 1 m.

1) SI are the initials of the International Unit System, defined and approved by the General Conference on Weights and Measures as the only system of units of measure. Ref. CNR UNI 10 003-84 (DIN 1 301-93 NF X 02.004, BS 5 555-93, ISO 1 000-92).  
UNI: Ente Nazionale Italiano di Unificazione.  
DIN: Deutscher Normenausschuss (DNA).  
NF: Association Française de Normalisation (AFNOR).  
BS: British Standards Institution (BSI).  
ISO: International Organization for Standardization.

2) Newton [N] is the force imparting an acceleration of 1 m/s<sup>2</sup> to a mass of 1 kg.

3) Kilogramme [kg] is the mass of the prototype kept at Sèvres (i.e. 1 dm<sup>3</sup> of distilled water at 4 °C).

4) Joule [J] is the work done when the point of application of a force of 1 N is displaced through a distance of 1 m.

Größe <sup>1)</sup> - Size <sup>1)</sup> M <sub>N2</sub> [daN m] - F <sub>r2</sub> [daN]	I <sup>2)</sup>	CI <sup>4)</sup>	ICI	2I <sup>5)</sup>	3I	2I «lang» «long»	3I «lang» «long»	C2I
<b>40<sup>3)</sup></b> 8,5 - 224								
<b>50</b> 17 - 315								
<b>63</b> 31,5 - 500								
<b>64</b> 40 - 500								
<b>80</b> 67 - 800								
<b>81</b> 80 - 800								
<b>100</b> 140 - 1 250								
<b>125</b> 280 - 2 000								
<b>140</b> 425 - 2 800								
<b>160</b> 630 - 3 550								
<b>180</b> 900 - 4 500								
<b>200</b> 1 280 - 5 600								
<b>225</b> 1 800 - 7 100								
<b>250</b> 2 570 - 9 000								
<b>280</b> 3 550 - 11 200								
<b>320</b> 4 500 - 14 000								
<b>321</b> 5 600 - 14 000								
<b>360</b> 7 100 - 18 000								

1) Für größere Größen s. Kat. H.

2) Nur Getriebe.

3) Nur Getriebemotoren.

4) Auch C3I Größen 50 ... 125 (nur Getriebemotoren).

5) Auch 4I Größen 63 ... 125 (nur Getriebemotoren).

1) For greater sizes see cat. H.

2) Gearmotors reduce only.

3) Gearmotors only.

4) Also C3I sizes 50 ... 125 (gearmotors only).

5) Also 4I sizes 63 ... 125 (gearmotors only).

## 2 - Eigenschaften

«Symmetrische» Universalbefestigung: Waagrecht- oder Senkrechtmontagesfähigkeit

Stifes und präzises Monoblockgehäuse aus Gusseisen; hohe Ölkapazität

Langsamlaufende Hohlwelle serienmäßig, Vorbereitung für Rücklaufsperre, Option einer beidseitigen schnelllaufenden Welle

Einbaumöglichkeit leistungsstarker Motoren und hohe Belastbarkeit der Wellenenden

Ausführung geeignet für Mehrfach- und Winkelantriebe um 90° zueinander versetzt, bei freier Wahl der Drehrichtung der Antriebs- bzw. Abtriebswellen

Zwischengrößen 140, 180, 225, 280, 360 – ähnliche Abmessungen wie die Vorgößen 125, 160, 200, 250, 320, «vorstehende» Lagerung der langsamlaufenden Welle – **ausgedacht als Ergänzungsreihe für besondere Anwendungsfälle; drei Doppelgrößen**, normal und verstärkt, 63 und 64, 80 und 81, 320 und 321

Flexibilität bei der Fertigung und Materialwirtschaft

Hohe Fertigungsqualität

Nahezu wartungsfrei

Normmotor nach IEC

Hohe, zuverlässige und nachgeprüfte Leistungen

Umfangreiche Reihe von Größen, Zahnradgetrieben und Lösungen, weiter bereichert durch die Einführung der neuen Größe 40 und der neuen Serie von «langen» Stirnradgetrieben und -getriebemotoren für Anwendungen mit Motor/Maschinenwelle-U-Position und erheblich distanzierter Antriebs- und Abtriebswellen: Selbe Antriebs- und Abtriebskupplungsabmessungen, selbe Übersetzungen und Leistungen, selbe Motor/Getriebekombinationen der normalen Serie (**Patentanmeldung**).

In dieser Serie von Getrieben und Getriebemotoren werden die geschätzten Funktionseigenschaften der Stirnrad- und Kegelstirnradgetriebe – **Robustheit, Präzision, Zuverlässigkeit** – mit den Vorteilen eines modernen Konzeptes in der Konstruktion, Fertigung und Materialwirtschaft – **Eignung auch für die schwersten Betriebe, Universalität und Einsatzfreundlichkeit, umfangreiche Größenreihe, Service, Wirtschaftlichkeit** – hochqualitativer und in Großserie gebauter Getriebe ver-

Komplette Austauschbarkeit - bei derselben Größe - unabhängig von Zahnradgetriebe.

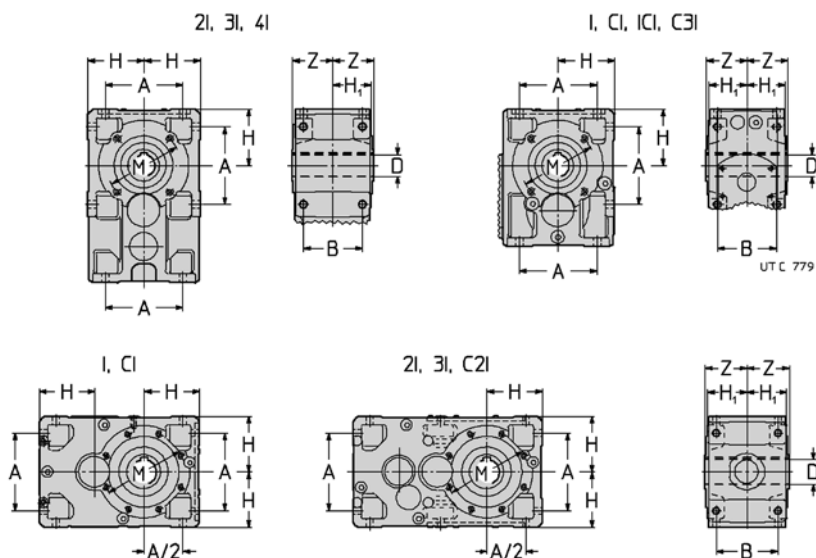

Fully interchangeable gear reducers – of the same size – independently from train of gears.

## a - Getriebe

### Baumerkmale

Haupteigenschaften:

- **Universalbefestigung** mit gehäuseeigenen Füßen auf 4 Seiten (3 Seiten Zahnradgetriebe; I Größen 63 ... 100, CI Größen 40 ... 100, C3I, IC1) und mit B14-Flansch auf 2 Seiten (1 Seite für normales Modell 2l, 3l und 4l Größen 40 ... 125); Getriebe und Getriebemotoren 2l, 3l Größen 40 ... 125 und 4l Größen 63 ... 125 mit Aussparung für Aufsteckbefestigung (s. Kap. 20); B5-Flansch mit «Zentrierbohrung» auf B14-Flanschseiten einbaubar (s. Kap. 22); Konstruktion und Robustheit des Gehäuses gestatten **bemerkenswerte Aufsteckbefestigungslösungen**, Paarungen mit Motoren in Fußausführung (s. Kap. 21) und Befestigungen von Hilfsvorrichtungen;
- Getriebegestaltung derart ausgelegt, um erhebliche Motorgrößen einzusetzen, **hohe Maximal- und Nenn Drehmomente** zu übertragen und **hohe Belastungen auf den langsam- und schnelllaufenden Wellenenden** aufzunehmen;
- **serienmäßig mit langsamlaufender Hohlwelle** aus Stahl, mit Passfeder und Sicherungsringnuten für Ausziehvorgang (ausschließlich Größen 40 und 63); normale (einseitig rechts oder links vorstehend) oder beidseitig vorstehende langsamlaufende Welle (s. Kap. 22).

## 2 - Specifications

Universal «symmetrical» mounting: suitable for horizontal or vertical mounting

Rigid and precise monolithic cast iron casing; high oil capacity Standard hollow low speed shaft, prearranged for installation of backstop device, option of double extension high speed shaft

Possibility of fitting particularly powerful motors and capable of withstanding high loads on the shaft end

Possibility of obtaining multiple and 90° drivers without restriction on direction of rotation of input/output shafts

Intermediate sizes 140, 180, 225, 280, 360 – dimensions similar to their previous sizes 125, 160, 200, 250, 320 «extended» low speed shaft bearings – **conceived to be also a supporting series in particular applications; three size pairs**, standard and strengthened, 63 and 64, 80 and 81, 320 and 321

Manufacturing and product management flexibility

High manufacturing quality standard

Minimum maintenance requirements

Motor standardized to IEC

High, reliable and tested performances

Wide range of sizes, trains of gears and solutions, further on improved with the insertion of the new size 40 and the new «long» series of parallel shaft **gear reducers** and **garmotors** for applications with «U» position of motor/machine shaft and **considerable distance** between input and output shafts: same input and output coupling dimensions, same transmission ratios and performances, same combinations of motors and gear reducers as the standard series (**patent pending**).

This series of gear reducers and gearmotors combines and exalts the traditional qualities of parallel and right angle shaft gear reducers – **strength, accuracy, and reliability** – with advantages derived from modern design, manufacturing and operating criteria – **suitability for the heaviest duties, universality and ease of application, wide size range, service, economy** – the advantages typically associated with high quality gear reducers produced in large series.

## a - Gear reducer

### Main structural features

Main specifications are:

- **universal** mounting having feet integral with casing on 4 faces (on 3 faces for train of gears: I sizes 63 ... 100, CI sizes 40 ... 100, C3I, IC1) and with B14 flange on 2 faces (1 face for 2l, 3l and 4l sizes 40 ... 125 standard model); gear reducers and gearmotors 2l, 3l sizes 40 ... 125 and 4l sizes 63 ... 125 with reaction embedding for shaft mounting system (see ch. 20); B5 flange with spigot «recess» mountable on faces with B14 flange (see ch. 22); design and strength of casing permit **interesting** shaft mounting **solutions**, foot-mounted motors fitting (see ch. 21) and connections for fitting auxiliary devices;
- gear reducer overall sized so as to accept particularly powerful motors, to permit the transmission of **high** nominal and maximum **torques**, and to withstand **high loads** on the high and low speed **shaft ends**;
- **standard hollow low speed shaft** in steel, with keyway and circlip grooves for extraction (excluding sizes 40 ... 63); standard (left or right hand extension) or double extension low speed shaft (see ch. 22).



## 2 - Eigenschaften

- Getriebemotoren MR 4l (Größen 63 ... 125), MR C3l (Größen 50 ... 125) mit aus **2** Koaxialstirnradpaaren bestehender **Vorstufe**, um hohe Übersetzungen mit Normmotor kompakt- und ökonomischerweise zu bekommen;
- ausgereiftes Baukastensystem bei den Einzelheiten und beim Endprodukt;
- Normabmessungen und Normentsprechung;
- Getriebe: Antriebsseite mit bearbeiteter Fläche (Flansch bei R 3l 63 ... 125, R ICl) und Bohrungen; schnelllaufendes Wellenende mit Passfeder;
- Getriebemotoren: Direkt mit der schnelllaufenden Hohlwelle verbundener **Normmotor nach IEC** (MR 2l, MR 3l 140 ... 360, MR Cl, MR C2l); bei Motorgröße 200 ... 315 **patentiertes** Verbindungsverfahren mit Passfeder und Bronzebuchse und, nur bei MR 2l, 3l, Passfeder und Bronzebuchse mit Stellring für eine optimale Fluchtung für leichteren Ein- und Ausbau und gegen Berührungsrostung: **Normmotor nach IEC** mit direkt auf Wellenende montiertem Ritzel (MR 3l 40 ... 125, MR 4l, MR ICl und MR C3l);
- Option einer **zweiten vorstehenden schnelllaufenden** Welle (bzw. Zwischenwelle bei Zahnradgetriebe 3l 40 ... 125, 4l, ICl, C3l);
- Kegelrollenlager mit Ausnahme einiger schnelllaufenden Wellen, wobei Zylinderrollen- oder Kugellager angewandt werden;
- Monoblockgehäuse aus **Gusseisen** 200 UNI ISO 185 (**Sphärogusseisen** UNI ISO 1083 bei Größen 140, 180, 225, 280, 360) mit **Versteifungsrippen** und **großer Ölkapazität**;
- Ölbadschmierung; Synthetiköl für **«Lebensdauerschmierung»** und mit 1 Schraube (Größen 40 ... 64) oder 2 Schrauben (Größen 80 und 81) mit **Ölfüllung** geliefert; Synthetik- oder Mineralöl (Kap. 21) mit Öleinfüllschraube mit **Ventil**, Ölablass- und Ölstands-schraube (Größen 100 ... 360); Dichtigkeit;
- Zusatzschmierung der Lager mit entsprechenden Leitungen oder Pumpe (Größen 100 ... 360);
- eigene oder zusätzliche Kühlung (mit Lüfter – auch mit **Flanschbefestigung** – und/oder Kühlschlange, s. Kap. 22);
- Lackierung: Außenschutz mit Epoxypulverlack (Größen 40 ... 81) oder Synthetiklack (100 ... 360) für normale Anwendung in Industriestätten und für Nachbehandlungen mit weiteren Synthetiklacken geeignet; Farbton blau RAL 5010 DIN 1843; Innenschutz mit synthetikölbeständigem Epoxypulverlack (Größen 40 ... 81) oder mit Synthetiklack (Größen 100 ... 360) gegen Mineralöle bzw. Synthetiköle auf Polyalphaolefine Basis beständig;
- Ausführbarkeit von Kombinationen Getriebe und Getriebemotoren mit hohen Übersetzungen;
- Sonderausführungen: Rücklauf Sperre (Vorbereitung serienmäßig, außer Größe 40 und bei Stirnradgetr. Größe 50), abgestufte langsamlaufende Hohlwelle, zusätzliche Kühlungs- u. Schmierungsverfahren, Aufsteckbefestigungen, Sonderlackierungen, **ATEX II 2 GD und 3 GD**, Ausführung für Extruder, Rührwerke, usw. (Kap. 22).
- **neuer «langer» Stirnradtyp** ist durch den normalen Typ mit der Einführung eines **Zwischenrads** zwischen Rad und Ritzel der vorletzten Unterstufe (erste Unterstufe für Zahnradgetriebe 2l) gegeben, um die Antriebs- und Abtriebswellen **erheblich zu distanzieren** und um die **Eigenschaften und Leistungen** des normalen Typs **ungeändert** behalten zu können. Im Einzelnen haben wir:
  - selbe **Antriebs- und Abtriebskupplungsabmessungen** (Wellen und B14-Abtriebsflasche, Motorgröße);
  - selbe **Lagerungen** (Lager und Wellen) der schnelllaufenden Welle bei derselben Übersetzung;
  - selbe **Fußbefestigungsabmessungen** (außer A<sub>1</sub>-Abmessung);
  - selbe **Übersetzungen und Leistungen**;
  - selbe **Motor/Getriebe-Kombinationen**;
  - selbe **Wärmeleistung** (dank der Gehäuseverlängerung);
  - selbes **Zubehör** und **Sonderausführungen**;
  - selbes **hohes Qualitätsniveau** (Designlösungen, Herstellungsprozess und Prüfung, Komponenten, Monoblockgehäuse, Baukastensystem, Ästhetik).

Das «lange» Getriebe, das durch diese Baulösung erreicht worden ist, bietet auch sehr niedrige Übersetzungen mit geeigneten erheblich dimensionierten Lagerungen von Lagern und Wellendurchmessern der langsamlaufenden Welle.

**Alles**, was in diesem Katalog angegeben ist, **gilt sowohl für das normale als auch für das lange Modell**, außer abweichender und expliziten Angabe.

Vergleich zwischen Getriebe R 2l 250 normales Modell UP2D und dem entsprechenden langen Modell **UP4D (Patentanmeldung)**; wichtig ist die Verlängerung der Achsabstände, das Vorhandensein des Zwischenrades und die Inversion der Drehrichtungen.

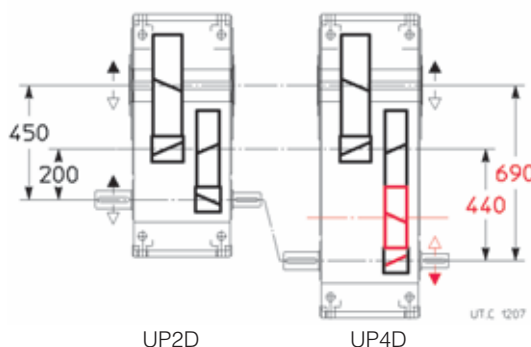

Comparison between the standard UP2D gear reducer R 2l 250 and the corresponding long model **UP4D (patent pending)**: centre distances, idle gear and reversal of rotation directions are here highlighted.

## 2 - Specifications

- gearmotors MR 4l (sizes 63 ... 125), MR C3l (sizes 50 ... 125) with **first reduction stage** consisting of **2** coaxial cylindrical gear pairs to have high transmission ratios, with standardized motor, in a compact and economic way;
- improved and up-graded modular construction both for component parts and assembled product;
- standardized dimensions and conformity to current standards;
- gear reducers: input face with machined surface (flange for R 3l 63 ... 125, R ICl) with fixing holes; high speed shaft end with key;
- gearmotors: **motor standardized to IEC** directly keyed into hollow high speed shaft (MR 2l, MR 3l 140 ... 360, MR Cl, MR C2l); for motor sizes 200 ... 315 **patented** keying system with key and bronze bush and, only for MR 2l, 3l, key and bronze bush with hub clamp for a perfect alignment, to obtain easier installing and removal and avoid fretting corrosion; **motor standardized to IEC** with pinion directly mounted onto the shaft end (MR 3l 40 ... 125, MR 4l, MR ICl and MR C3l);
- possibility of **second high speed shaft extension** (or intermediate shaft extension for train of gears 3l 40 ... 125, 4l, ICl, C3l);
- taper roller bearings, excluding some shafts (high speed shaft) on which bearings are cylindrical roller or ball type;
- monolithic **cast iron** casing 200 UNI ISO 185 (**spheroidal UNI ISO 1083** for sizes 140, 180, 225, 280, 360) with **stiffening ribs** and **high oil capacity**;
- oil bath lubrication; synthetic oil providing lubrication **«for life»**, with 1 (sizes 40 ... 64) or 2 plugs (sizes 80, 81), supplied **filled with oil**; synthetic or mineral oil (ch. 21) with filler plug with **valve**, drain and level plugs (sizes 100 ... 360); sealed;
- additional bearings lubrication through proper pipelines or pump (sizes 100 ... 360);
- natural or forced cooling (fan – also in **flange** mounting – and/or coil, see ch. 22);
- paint: external coating in epoxy powder paint (sizes 40 ... 81) or in synthetic paint (sizes 100 ... 360) appropriate for resistance to normal industrial environments and suitable for the application of further coats of synthetic paint; colour blue RAL 5010 DIN 1843; internal protection in epoxy powder paint (sizes 40 ... 81) appropriately resistant to synthetic oils, or with synthetic paint (sizes 100 ... 360) providing resistance to mineral oils or to polyalphaolefines synthetic oils;
- possibility of obtaining combined gear reducer and gearmotor units providing high transmission ratios;
- non-standard designs: backstop device (always prearranged, size 40 and parallel shafts size 50 excluded), stepped hollow low speed shaft, supplementary cooling and lubrication systems, shaft mounting arrangements, special paints, **ATEX II 2 GD and 3 GD**, design for extruders, agitators, etc. (ch. 22).
- **new parallel shaft «long» model**: it is derived from the standard one (completing it) through the addition of an **idle gear** between wheel and pinion of the second-last reduction stage (first reduction stage for 2l train of gears) hence allowing **to distance considerably** the input and output shafts, whilst maintaining **the same specifications and performances** as the standard model. In particular:
  - same **input and output coupling dimensions** (shafts and B14 out-put flange, motor sizes);
  - same **high speed shaft bearing** (shafts and bearings) with the same transmission ratio;
  - same **foot mounting dimensions** (A<sub>1</sub> dimension excluded);
  - same **transmission ratios and performances**;
  - same **combinations of motors and gear reducers**;
  - same **thermal power** (thanks to the greater length of the casing);
  - same **accessories** and **non-standard designs**;
  - same **high quality level** (design solutions, production processes and tests, components, monolithic casing, modular and aesthetic design).

The «long» gear reducer obtained through this new design concept, makes possible also very low transmission ratios with proportioned and generous bearings in terms of high speed shaft roller bearings and shaft diameters.

**Everything** stated in this catalogue is to be intended **valid both for standard and long model**, except otherwise stated.

## 2 - Eigenschaften

## 2 - Specifications



Stirnradtriebemotor mit **Rücklaufsperre** (Vorbereitung serienmäßig).  
Parallel shaft gearmotor with **backstop device** (always prearranged).



Kegelstirnradtriebemotor CI (auch C2I) mit schnellaufender Welle für **90° Mehrfachwinkelantriebe**.  
Right angle shaft gearmotor CI (also C2I) with high speed shaft for **90° multiple drives**.



Kegelstirnradtriebemotor ICI (auch CI) mit beidseitig vorstehender langsamlaufender Welle und **schnellaufender vorstehender Welle** (Ausführ. UO3D).  
Right angle shaft gearmotor ICI (also CI) with double extension low speed shaft and **high speed shaft extension** (design UO3D).

### Zahnradgetriebe:

- mit 1, 2, 3, 4 Stirnradpaaren (Stirnradgetriebe);
- mit 2, 3 Stirnradpaaren und **1 Zwischenrad** (Stirnradgetriebe, langer Typ);
- mit 1 Kegelrad- und 1, 2, 3 Stirnradpaaren (Kegelstirnradgetriebe);
- 6 Größen mit Enduntersetzungsachsabstand nach Normzahlreihe R 10 (40 ... 125, wovon 2 doppelt sind: normal und verstärkt); 9 Größen mit Enduntersetzungsachsabstand nach R 20 (140 ... 360, wovon 1 doppelt ist: normal und verstärkt), mit insgesamt **18 Größen**;
- Nennübersetzungen nach Normzahlreihe R 10 ( $i_N = 2,5 \dots 160$ ;  $i_N = 80 \dots 400$  bei 4I) für Stirnradgetriebe; nach Normzahlreihe R 10 ( $i_N = 5 \dots 200$ ;  $i_N = 80 \dots 500$  bei C3I) für Kegelstirnradgetriebe; nach Normzahlreihe R 20 ( $i_N = 9 \dots 90$ ), außer I und ICI, bei den Größen 140 ... 360;
- einsatzgehärtete Zahnradpaare aus Stahl 16 CrNi4 oder 20 MnCr5 (je nach Größe) und 18 NiCrMo5 UNI EN 10084;
- Stirnradpaare mit Schrägverzahnung und **geschliffenem** Profil;
- Kegelradpaare mit GLEASON-Kreisbogen-Verzahnung mit **geschliffenem** oder sorgfältig geläppter Profil;
- auf Zahnfußtragfähigkeit und Zahnflankentragsfähigkeit (Grübchenbildung) berechnete Belastbarkeit des Zahnradgetriebes.

### Train of gears:

- 1, 2, 3, 4 cylindrical gear pairs (parallel shafts);
- 2, 3 cylindrical gear pairs and **1 idle gear** (parallel shafts, «long» model);
- 1 bevel gear pair plus 1, 2, 3 cylindrical gear pairs (right angle shafts);
- 6 sizes, with final reduction centre distance to R 10 (40 ... 125, with 2 size pairs: standard and strengthened); 9 sizes with final reduction centre distance to R 20 series (140 ... 360, with 1 size pair: standard and strengthened), for a total of **18 sizes**;
- nominal transmission ratios to R 10 series ( $i_N = 2,5 \dots 160$ ;  $i_N = 80 \dots 400$  for 4I) for parallel shafts, to R 10 series ( $i_N = 5 \dots 200$ ;  $i_N = 80 \dots 500$  for C3I) for right angle shafts; to R 20 series ( $i_N = 9 \dots 90$ ), except I and ICI, for all sizes 140 ... 360;
- casehardened and hardened gear pairs in 16 CrNi4 or 20 MnCr5 steel (depending on size) and 18 NiCrMo5 steel, according to UNI EN 10084;
- helical toothed cylindrical gear pairs with **ground** profile;
- GLEASON spiral bevel gear pairs with **ground** or accurately lapped profile;
- gears load capacity calculated for tooth breakage and pitting.

### Schallpegel $L_{WA}$ und $\bar{L}_{pA}$ [dB(A)]

Normalwerte des Schalleistungspegels  $L_{WA}$  [dB(A)]<sup>1)</sup> und des mittleren Schalldruckpegels  $\bar{L}_{pA}$  [dB(A)]<sup>2)</sup> bei Nennbelastung und Antriebsdrehzahl  $n_1 = 1\ 400$ <sup>3)</sup> min<sup>-1</sup>. Messungstoleranz +3 dB(A).

### Sound levels $L_{WA}$ and $\bar{L}_{pA}$ [dB(A)]

Standard production sound power level  $L_{WA}$  [dB(A)]<sup>1)</sup> and mean sound pressure level  $\bar{L}_{pA}$  [dB(A)]<sup>2)</sup> assuming nominal load, and input speed  $n_1 = 1\ 400$ <sup>3)</sup> min<sup>-1</sup>. Tolerance +3 dB(A).

Größe Size	Stirnradgetriebe Parallel shaft gear reducers								Kegelstirnradgetriebe Right angle shaft gear reducers									
	R I		R 2I				R 3I, R 4I		R CI		R ICI, R C2I, R C3I							
	$i_N \leq 3,15$	$i_N \geq 4$	$i_N \leq 14$	$i_N \geq 16$	$i_N \leq 90$	$i_N \geq 100$	$i_N \leq 18$	$i_N \geq 20$	$i_N \leq 80$ (ICI) $i_N \leq 71$ (C2I)	$i_N \geq 100$ (ICI, C3I) $i_N \geq 80$ (C2I)	$L_{WA}$	$\bar{L}_{pA}$	$L_{WA}$	$\bar{L}_{pA}$	$L_{WA}$	$\bar{L}_{pA}$		
<b>40, 50</b>	—	—	<b>75</b>	66	<b>72</b>	63	<b>71</b>	64	—	—	<b>73</b>	64	<b>71</b>	62	<b>71</b>	62	<b>71</b>	62
<b>63, 64</b>	<b>83</b>	74	<b>79</b>	70	<b>78</b>	69	<b>75</b>	66	<b>74</b>	64	<b>72</b>	62	<b>76</b>	67	<b>73</b>	64	<b>73</b>	64
<b>80, 81</b>	<b>86</b>	77	<b>82</b>	73	<b>81</b>	72	<b>78</b>	69	<b>77</b>	67	<b>75</b>	65	<b>79</b>	70	<b>75</b>	66	<b>75</b>	66
<b>100</b>	<b>89</b>	80	<b>85</b>	76	<b>84</b>	75	<b>81</b>	72	<b>80</b>	70	<b>78</b>	68	<b>82</b>	73	<b>78</b>	69	<b>78</b>	69
<b>125, 140</b>	<b>92</b>	83	<b>88</b>	79	<b>87</b>	77	<b>84</b>	74	<b>83</b>	73	<b>80</b>	70	<b>85</b>	76	<b>80</b>	71	<b>82</b>	72
<b>160, 180</b>	<b>95</b>	86	<b>91</b>	82	<b>90</b>	79	<b>87</b>	76	<b>86</b>	75	<b>83</b>	72	<b>88</b>	79	<b>83</b>	74	<b>84</b>	74
<b>200, 225</b>	<b>99</b> <sup>4)</sup>	89 <sup>4)</sup>	<b>95</b> <sup>4)</sup>	85 <sup>4)</sup>	<b>93</b>	82	<b>90</b>	79	<b>89</b>	78	<b>86</b>	75	<b>92</b>	82	<b>87</b>	77	<b>87</b>	76
<b>250, 280</b>	<b>102</b> <sup>4)</sup>	92 <sup>4)</sup>	<b>98</b> <sup>4)</sup>	88 <sup>4)</sup>	<b>96</b>	85	<b>93</b>	82	<b>92</b>	81	<b>89</b>	78	<b>94</b>	84	<b>89</b>	79	<b>90</b>	79
<b>320 ... 360</b>	<b>106</b> <sup>4)</sup>	96 <sup>4)</sup>	<b>102</b> <sup>4)</sup>	92 <sup>4)</sup>	<b>100</b>	89	<b>97</b>	86	<b>96</b>	85	<b>93</b>	82	<b>98</b>	88	<b>93</b>	83	<b>93</b>	82

1) Nach ISO/CD 8579.

2) Mittelwerte gemessen bei 1 m Abstand von der Getriebe-Außenseite im freien Feld und auf Reflexionsfläche.

3) Im Bereich zwischen  $n_1 = 710 \div 1\ 800$  min<sup>-1</sup>, Tabellenwerte wie folgt aufrechnen: bei  $n_1 = 710$  min<sup>-1</sup>, -3 dB(A); bei  $n_1 = 900$  min<sup>-1</sup>, -2 dB(A); bei  $n_1 = 1\ 120$  min<sup>-1</sup>, -1 dB(A); bei  $n_1 = 1\ 800$  min<sup>-1</sup>, +2 dB(A).

4) Wertzunahme um 1 dB(A) bei Größen R 1225, 280 und 360.

Bei Getriebemotor (Motor von ROSSI MOTORIDUTTORI geliefert) die Tabellenwerte mit 1 dB(A) für 4-polige 50 Hz Motoren und mit 2 dB(A) für 4-polige 60 Hz Motoren addieren.

Bei Bedarf sind Getriebe mit herabgesetzten Schallpegelwerten erhältlich (normalerweise um 3 dB(A) geringer als in Tabelle): Bitte rückfragen.

Mit Getriebe mit zusätzlicher Kühlung mit Lüfter die Tabellenwerte mit 3dB(A) für einen Lüfter und mit 5 dB(A) für 2 Lüfter addieren.

1) To ISO/CD 8579.

2) Mean value of measurement at 1 m from external profile of gear reducer standing in free field on a reflecting surface.

3) For  $n_1 = 710 \div 1\ 800$  min<sup>-1</sup>, modify tabulated values: thus  $n_1 = 710$  min<sup>-1</sup>, -3 dB(A);  $n_1 = 900$  min<sup>-1</sup>, -2 dB(A);  $n_1 = 1\ 120$  min<sup>-1</sup>, -1 dB(A);  $n_1 = 1\ 800$  min<sup>-1</sup>, +2 dB(A).

4) For sizes R 1225, 280 and 360, increase values of 1 dB(A).

In case of gearmotor (motor supplied by ROSSI MOTORIDUTTORI) add 1 dB(A) to the values in the table for 4 poles 50 Hz motors, and add 2 dB(A) for 4 poles 60 Hz motors.

If required, gear reducers can be supplied with reduced sound levels (normally 3 dB(A) less than tabulated values): consult us.

In case of gear reducer with fan cooling, add to the values in the table 3 dB(A) for 1 fan and 5 dB(A) for 2 fans.



## 2 - Eigenschaften

### Spezifische Normen:

- Nennübersetzungen und Hauptabmessungen nach Normzahlen UNI 2016 (DIN 323-74, NF X 01.001, BS 2045-65, ISO 3-73);
- Zahnprofil nach UNI 6587-69 (DIN 867-86, NF E 23.011, BS 436.2-70, ISO 53-74);
- Achshöhen nach UNI 2946-68 (DIN 747-76, NF E 01.051, BS 5186-75, ISO 496-73);
- von UNEL 13501-69 (DIN 42948-65, IEC 72.2) abgeleitete Befestigungsflansche B14 und B5 (letztere mit «Zentrierbohrung»);
- Befestigungsbohrungen der mittleren Reihe nach UNI 1728-83 (DIN 69-71, NF E 27.040, BS 4186-67, ISO/R 273);
- zylindrische (lange oder kurze) Wellenenden nach UNI ISO 775-88 (DIN 748, NF E 22.051, BS 4506-70, ISO/R775); mit kopfseitiger Gewindebohrung nach UNI 9321 (DIN 332 Bl. 2-70, NF E 22.056) außer Übereinstimmung d-D;
- UNI 6604-69 Paßfedern (DIN 6885 Bl. 1-68, NF E 27.656 und 22.175, BS 4235.1-72, ISO/R/773-69) mit Ausnahme von bestimmten Motor-Getriebepaaraarungen, wobei sie abgeflacht sind;
- von CEI 2-14 (DIN EN 60034-7, IEC 34.7) abgeleitete Bauformen;
- Tragfähigkeitsnachweis nach UNI 8862, DIN 3990, AFNOR E 23-015, und ISO 6336 für Betriebsdauer  $\geq 25\ 000$  h; Nachprüfung der Wärmeleistung.

## b - Elektromotor

### Normalausführung:

- **Normmotor** nach IEC;
- geschlossener Asynchron-Käfigläufer-Drehstrommotor mit Außenbelüftung;
- Einzelpolarität, Frequenz 50 Hz, Spannung  $\Delta 230\ V\ Y\ 400\ V \pm 5\%$ <sup>1)</sup> bis zur Größe 132,  $\Delta 400\ V \pm 5\%$  ab Größe 160;
-  Drehstrommotoren Größen 80 ... 280, 2- und 4-polig, 400 V 50 Hz (nur IC 411) mit **erhöhtem eff2-Wirkungsgrad**.
- Schutzart IP 55, Isolationsklasse F, Übertemperatur Klasse B<sup>2)</sup>;
- die Leistung gilt für Dauerbetrieb (S1) bei Normalspannungen und -frequenzen; max Umgebungstemperatur 40 °C und max Aufstellungshöhe 1 000 m: Bei höheren Werten bitte rückfragen;
- eine oder mehrere Überbelastungen – von 1,6-facher Nennbelastung – sind für max Einwirkungszeit 2 min pro Stunde erlaubt;
- das Anlaufmoment ist bei direkter Einschaltung mindestens das 1,6-fache des Nennmoments (normalerweise liegt es höher);
- B5-Bauform und deren Ableitungen, s. folgende Tabelle;
- **geeignet für Frequenzrichterbetrieb** (reichlich elektromagnetische Dimensionierung, Elektrolech mit niedrigen Verlusten, Phasentrennung, usw.);
- umfangreiche Reihe von Ausführungen für jede Anfrage: Schwungrad, Fremddaxillüfter, Fremddaxillüfter und Drehgeber, usw.);
- Sonderausführung für Anwendung in Zonen mit potentiell explosibler Atmosphäre nach  ATEX 94/9/CE-Richtlinie, Kategorien 2 GD (2 G mit explosionsgeschützten Motoren) und 3 GD (s. Kap. 22).

Bei anderen Eigenschaften und Details s. **gesonderte Unterlage**.

- 1) Nennmotorspannungsbereich; für die minimalen und maximalen Motorversorgungsgrenzen ist ein weiterer  $\pm 5\%$  zu betrachten, z.B.: ein Motor  $\Delta 230\ Y 400\ V$  mit Spannungsbereich  $\pm 5\%$  ist für Netzspannungen bis zu  $\Delta 220\ Y 380\ V$  und  $\Delta 240\ Y 415\ V$  geeignet.
- 2) Übertemperaturklasse F für einige Motoren mit Leistung oder nicht genormter Entsprechung Leistung-Motorgröße und Motoren 200LR 6, 200L 6.

Motorgröße Motor size	Hauptpaarungsabmessungen Main coupling dimensions UNEL 13117-71 (DIN 42677 Bl 1.A-65, IEC 72.1)	
	Wellenende Shaft end $\varnothing D \times E$	Flansch $\varnothing P$ Flange $\varnothing P$ B5
<b>63, 71 B5R</b>	11 × 23	140
<b>71, 80 B5R</b>	14 × 30	160 <sup>1)</sup>
<b>80, 90 B5R<sup>3)</sup></b>	19 × 40	200 <sup>2)</sup>
<b>90, 100L B5R<sup>4)</sup></b>		
<b>112M B5R<sup>4)</sup></b>	24 × 50	200
<b>100, 112, 132M B5R<sup>4)</sup></b>	28 × 60	250
<b>132, 160 B5R</b>	38 × 80	300

- 1) Für Getriebemotor MR 2l 40  $\varnothing P$  140 mm; Bezeichnung Bauform B5A.
- 2) Für Getriebemotor MR 2l 50  $\varnothing P$  160 mm; Bezeichnung Bauform B5A.
- 3) Bauform **B5R** nicht vorgesehen für Motor **90S**; Motor **80C B5** anwenden.
- 4) Motorlänge **Y** und Außenmaße **Y**, (Kap. 13 und 16) erhöhen sich um 22 mm bei Größen 100 und 112, 29 mm bei Größe 132.



## 2 - Specifications

### Specific standards:

- nominal transmission ratios and main dimensions according to UNI 2016 standard numbers (DIN 323-74, NF X 01.001, BS 2045-65, ISO 3-73);
- tooth profiles to UNI 6587-69 (DIN 867-86, NF E 23.011, BS 436.2-70, ISO 53-74);
- shaft heights to UNI 2946-68 (DIN 747-76, NF E 01.051, BS 5186-75, ISO 496-73);
- fixing flanges B14 and B5 (the latter with spigot «recess») taken from UNEL 13501-69 (DIN 42948-65, IEC 72.2);
- medium series fixing holes to UNI 1728-83 (DIN 69-71, NF E 27.040, BS 4186-67, ISO/R 273);
- cylindrical shaft ends (long or short) to UNI ISO 775-88 (DIN 748, NF E 22.051, BS 4506-70, ISO/R775) with tapped butt-end hole to UNI 9321 (DIN 332 Bl. 2-70, NF E 22.056) excluding d-D diameter ratio;
- parallel keys to UNI 6604-69 (DIN 6885 Bl. 1-68, NF E 27.656 and 22.175, BS 4235.1-72, ISO/R/773-69) except for specific cases of motor-to-gear reducer coupling where key height is reduced;
- mounting positions derived from CEI 2-14 (DIN EN 60034-7, IEC 34.7);
- load capacity verified according to UNI 8862, DIN 3990, AFNOR E 23-015, and to ISO 6336 for running time  $\geq 25\ 000$  h; thermal capacity verified.

## b - Electric motor

### Standard design:

- motor **standardized to IEC**;
- asynchronous three-phase, totally-enclosed, externally ventilated, with cage rotor;
- single polarity, frequency 50 Hz, voltage  $\Delta 230\ V\ Y\ 400\ V \pm 5\%$ <sup>1)</sup> up to size 132,  $\Delta 400\ V \pm 5\%$  from size 160 upwards;
-  **Improved efficiency** three-phase motors, sizes 80 ... 280, 2 and 4 poles, 400 V 50 Hz (IC 411 only) according to eff2 class limit.
- IP 55 protection, insulation class F, temperature rise class B<sup>2)</sup>;
- rated power delivered on continuous duty (S1) and at standard voltage and frequency; maximum ambient temperature 40 °C, max altitude 1 000 m: consult us if higher;
- capacity to withstand one or more overloads up to 1,6 times the nominal load for a maximum total period of 2 min per single hour;
- starting torque with direct on-line start at least 1,6 times the nominal one (it is usually higher);
- mounting position B5 and derivatives as shown in the following table.
- **suitable for running with inverter** (generous electromagnetic sizing, low-loss electrical stamping, phase separators, etc.);
- design available for every application need; flywheel, independent cooling fan, independent cooling fan and encoder, etc.);
- non-standard design for use in zones with potentially explosive atmosphere according to  ATEX 94/9/CE directive, categories 2 GD (2 G with flameproof motors) and 3 GD (see ch. 22).

For other specifications and details see **specific literature**.

- 1) Nominal voltage range of motor; for maximum and minimum motor supply limits consider a further  $\pm 5\%$ , e.g.: a  $\Delta 230\ Y 400\ V$  motor with voltage range  $\pm 5\%$  is suitable for nominal mains voltages up to  $\Delta 220\ Y 380\ V$  and  $\Delta 240\ Y 415\ V$ .
- 2) Temperature rise class F for some motors with power-to-size correspondance not according to standard and motors 200LR 6, 200L 6.

Motorgröße Motor size	Hauptpaarungsabmessungen Main coupling dimensions UNEL 13117-71 (DIN 42677 Bl 1.A-65, IEC 72.1)	
	Wellenende Shaft end $\varnothing D \times E$	Flansch $\varnothing P$ Flange $\varnothing P$ B5
<b>160</b>	42 × 110	350
<b>180, 200 B5R</b>	48 × 110	350
<b>200</b>	55 × 110	400
<b>225, 250 B5R</b>	60 × 140	450
<b>250</b>	65 × 140	550
<b>280, 315S B5R</b>	75 × 140	550
<b>315</b>	80 × 170	660

- 1) Gearmotor MR 2l 40 has a 140  $\varnothing P$ ; mounting position designation B5A.
- 2) Gearmotor MR 2l 50 has a 160  $\varnothing P$ ; mounting position designation B5A.
- 3) **B5R** mounting position not available for motor **90S**; adopt motor **80C B5**.
- 4) Motor length **Y** and overall dimensions **Y**, (ch. 13 and 16) increase of 22 mm for sizes 100 and 112, 29 mm for size 132.

## 2 - Eigenschaften

### Bremsmotor (vor der Bestellbezeichnung: **F0**):

- IEC-Normmotor mit gleichen Eigenschaften des Normalmotors;
- solide Bauweise, um den Bremsbeanspruchungen standzuhalten;
- **maximale Geräuscharmut**;
- elektromagnetische **Gs-** Federbremse; direkt vom Klemmenbrett gespeist; separate Bremspeisung vom Netz vorgesehen;
- dem Motordrehmoment **proportioniertes** Bremsmoment (normalerweise  $M_f \approx 2 M_N$ ) und einstellbar durch Zusatz oder Abnahme von Federpaaren;
- hohe Schalthäufigkeit;
- schnelles und genaues Anhalten;
- Handlüftung durch Hebel mit automatischer Rückstellung; Abnehmbare Hebelstange.

Bei anderen Eigenschaften und Details s. **gesonderte Unterlage**.

### Wichtig

Die polumschaltbaren Motoren im nächsten Abschnitt sind auch als «normale Bremsmotoren» Ausführung **F0** vorgesehen (s. betreffende Tabelle); mögliche Kombinationen und Leistungen der Getriebemotoren entsprechen den Angaben in Kap. 12 und 15.

### Haupteigenschaften der Normal- und Bremsmotoren (außer **FV0**) (50 Hz)

Motorgröße Motor size	$M_{f_{max}}$ ≈ daN m 2) 4)	2 polig - poles - 2 800 min <sup>-1</sup> 1)				4 polig - poles - 1 400 min <sup>-1</sup> 1)				6 polig - poles - 900 min <sup>-1</sup> 1)			
		$P_1$ kW	$J_0$ ≈ kg m <sup>2</sup> 2)	$z_0$ 3)	$M$ Anlauf - start. $M_N$ ≈ 3)	$P_1$ kW	$J_0$ ≈ kg m <sup>2</sup> 2)	$z_0$ 3)	$M$ Anlauf - start. $M_N$ ≈ 3)	$P_1$ kW	$J_0$ ≈ kg m <sup>2</sup> 2)	$z_0$ 3)	$M$ Anlauf - start. $M_N$ ≈ 3)
<b>63 A</b>	0,35	0,18	0,0002	4 750	2,5	0,12	0,0002	12 500	2,9	0,09	0,0004	12 500	2,7
<b>63 B</b>	0,35	0,25	0,0003	4 750	2,7	0,18	0,0003	12 500	2,8	0,12	0,0004	12 500	2,7
<b>63 C</b>	0,35	0,37*	0,0003	4 000	3	0,25*	0,0003	10 000	2,6	—	—	—	—
<b>71 A</b>	0,5	0,37	0,0004	4 000	3	0,25	0,0005	10 000	2,6	0,18	0,0012	11 200	2,4
<b>71 B</b>	0,5	0,55	0,0005	4 000	3	0,37	0,0007	10 000	2,5	0,25	0,0012	11 200	2,1
<b>71 C</b>	0,75	0,75*	0,0006	3 000	2,8	0,55*	0,0008	8 000	2,4	0,37*	0,0013	10 000	2,1
<b>71 D</b>	—	—	—	—	—	0,75*	0,0009	8 000	2,8	—	—	—	—
<b>80 A</b>	1,1	0,75	0,0008	3 000	2,5	0,55	0,0015	8 000	2,6	0,37	0,0019	9 500	2,1
<b>80 B</b>	1,6	1,1	0,0011	3 000	2,2	0,75	0,0019	7 100	2,9	0,55	0,0024	9 000	2,1
<b>80 C</b>	1,6	1,5 *	0,0013	2 500	2,9	1,1 *	0,0025	5 000	3	0,75*	0,0033	7 100	2,1
<b>80 D</b>	—	—	—	—	—	1,5 *	0,0028	5 000	2,7	—	—	—	—
<b>90 S</b>	1,6	1,5	0,0013	2 500	2,9	1,1	0,0025	5 000	3	0,75	0,0033	7 100	2,1
<b>90 SB</b>	1,6	1,85*	0,0014	2 500	2,8	—	—	—	—	—	—	—	—
<b>90 L</b>	2,7	—	—	—	—	1,5	0,0041	4 000	2,7	1,1	0,005	5 300	2,3
<b>90 LA</b>	2,7	2,2	0,0017	2 500	2,9	—	—	—	—	—	—	—	—
<b>90 LB</b>	2,7	3	0,0019	1 800	2,8	1,85*	0,0044	4 000	2,7	—	—	—	—
<b>90 LC</b>	2,7	—	—	—	—	2,2 *	0,0048	3 150	2,8	1,5 *	0,0055	5 000	2,5
<b>100 LA</b>	4	3	0,0035	1 800	2,7	2,2	0,0051	3 150	2,6	1,5	0,0104	3 550	2,6
<b>100 LB</b>	4	4*	0,0046	1 500	3,6	3	0,0069	3 150	2,9	1,85*	0,0118	3 150	2,5
<b>112 M</b>	7,5 <sup>5)</sup>	4	0,0046	1 500	3,6	4	0,0097	2 500	3,1	2,2	0,0142	2 800	2,9
<b>112 MB</b>	4	5,5*	0,0054	1 400	3,9	—	—	—	—	—	—	—	—
<b>112 MC</b>	7,5	7,5*	0,0076	1 060	4	5,5 *	0,0115	1 800	3,1	3 *	0,0169	2 500	2,9
<b>132 S</b>	7,5 <sup>5)</sup>	5,5	0,0099	1 250	3,1	5,5	0,0216	1 800	3	3	0,0216	2 360	2,3
<b>132 SB</b>	5	7,5	0,0118	1 120	3,1	—	—	—	—	—	—	—	—
<b>132 SC</b>	7,5	9,2*	0,0137	1 060	3,7	—	—	—	—	—	—	—	—
<b>132 M</b>	10	—	—	—	—	7,5	0,0323	1 250	3,2	4	0,0323	1 400	2,9
<b>132 MA</b>	10	11*	0,0178	850	3,7	—	—	—	—	—	—	—	—
<b>132 MB</b>	15	15*	0,0226	710	3,8	9,2 *	0,0391	1 060	3,6	5,5	0,0391	1 250	2,6
<b>132 MC</b>	15	—	—	—	—	11 *	0,0424	900	3,4	7,5 *	0,0532	1 000	2,4
<b>160 MR</b>	8,5	11	0,039	450	2,1	—	—	—	—	—	—	—	—
<b>160 M</b>	17	15	0,044	425	2,4	11	0,072	900	2	7,5	0,096	1 120	2
<b>160 L</b>	25	18,5	0,049	400	2,6	15	0,084	800	2,3	11	0,119	950	2,3
<b>180 M</b>	25	22	0,057	355	2,5	18,5	0,099	630	2,3	—	—	—	—
<b>180 L</b>	30	—	—	—	—	22	0,13	500	2,4	15	0,15	630	2,3
<b>200 LR</b>	40	30	0,185	160	2,4	—	—	—	—	18,5	0,19	500	2,1
<b>200 L</b>	40	37	0,2	160	2,5	30	0,2	400	2,4	22	0,24	400	2,4
<b>225 S</b>	—	—	—	—	—	37	0,32	—	2,3	—	—	—	—
<b>225 M</b>	—	—	—	—	—	45	0,41	—	2,4	30	0,47	—	2,4
<b>250 M</b>	—	—	—	—	—	55	0,52	—	2,3	37	0,57	—	2,6
<b>280 S</b>	—	—	—	—	—	75	0,89	—	2,5	45	0,85	—	2,4
<b>280 M</b>	—	—	—	—	—	90	1,06	—	2,7	55	1,07	—	2,5
<b>315 S</b>	—	—	—	—	—	110	1,15	—	2,6	75	1,45	—	2,3
<b>315 M</b>	—	—	—	—	—	132	2,1	—	2,5	90	2,6	—	2,5
<b>315 MB</b>	—	—	—	—	—	—	—	—	—	110	3	—	2,4
<b>315 MC</b>	—	—	—	—	—	160	2,5	—	2,5	—	—	—	—

1) Motordrehzahlen, anhand derer die Getriebemotordrehzahlen  $n_g$  bestimmt wurden.  
 2) Massenträgheitsmoment  $J_0$  und Bremsmoment  $M_f$  sind nur für Bremsmotor gültig (Größe  $\leq 200L$ ).  
 3) Bei Größe  $\leq 132$ ,  $M_{Anlauf} / M_N$  Werte und Schalthäufigkeit bei Leerlauf  $z_0$  [Anlauf/h] sind nur für Bremsmotor gültig.  
 4) Normalerweise sind die Motoren auf ein kleineres Bremsmoment eingestellt (s. **gesonderte Unterlage**).  
 5) Für 2-polige Motoren 112M: 4 daN m; für 2-polige Motoren 132S: 5 daN m.  
 \* Leistung oder nicht genormte Entsprechung Leistung-Motorgröße.

## 2 - Specifications

### Brake motor (prefix to designation: **F0**):

- motor **standardized IEC** having the same specifications as normal motor;
- particularly strong construction to withstand braking stresses;
- **maximum reduction of noise level**;
- spring-loaded **d.c.** electromagnetic brake; feeding from the terminal box; brake can also be fed independently direct from the line;
- braking torque **proportioned** to motor torque (usually  $M_f \approx 2 M_N$ ) and adjustable by adding or removing spring pairs;
- high frequency of starting enabled;
- rapid, precise stopping;
- hand lever for manual release with automatic return; removable lever rod.

For other specifications and details see **specific literature**.

### Important

Two-speed motors in the following paragraph are also available in «standard brake motor» design **F0** (see relevant table); combinations and gearmotor performance data therefore remain in the same as in ch. 12 and 15.

### Main specifications of normal and brake motors (FV0 excluded) (50 Hz)

1) Motor speed on the basis of which the gearmotor speeds  $n_g$  have been calculated.  
 2) Moment of inertia values  $J_0$ , braking torque values  $M_f$  are valid for brake motor (size  $\leq 200L$ ), only.  
 3) For size  $\leq 132$ ,  $M_{Anlauf} / M_N$  values and no load starting frequency  $z_0$  [start/h] values are valid for brake motor, only.  
 4) Motor is usually supplied with lower braking torque (see **specific literature**).  
 5) For 2 poles 112M: 4 daN m; for 2 poles 132S: 5 daN m.  
 \* Power or motor power-to-size correspondence not according to standard.

## 2 - Eigenschaften

### Bremsmotor für Fahrtriebe (vor der Bestellbezeichnung: **FV0**)

Motor in Sonderausführung für Fahrtriebe mit progressiven Anläufen und Anhalten. Auf diese Weise werden Rütteleffekte, Schlupf, heftige Überbelastungen, Schwingungen hängender Lasten zuverlässig und wirtschaftlich beseitigt.

Der progressive Anlauf ist das Ergebnis der Änderung der Kennlinie «Drehmoment-Winkelgeschwindigkeit» des Motors und der Verlängerung der Anlaufzeit mit dem Anstieg des Trägheitsmomentes  $J_0$  des Motors durch ein Schwungrad.

Die Motoren halten den langen Anlaufzeiten (2 ÷ 4 s) stand, die mit dem progressiven Anlauf verbunden sind.

Einschalthäufigkeit, s. entsprechendes Kapitel.

Der geschilderte progressive Anlauf läßt sich auch mit einem serien-geschalteten Widerstand auf einer bzw. mehreren Phasen bei dem Anlauf ergänzen: **Bei Bedarf bitte rückfragen.**

## 2 - Specifications

### Brake motor for traverse movements (prefix to designation: **FV0**)

Non-standard design of motor of traverse movements ensures progressive start and stop, avoiding problems of jerky operation, slip, excessive stress and oscillation of suspended loads, whilst remaining reliable and economic.

Progressive start is obtained by modifying the motor «torque-speed» characteristic curve, prolonging the starting time, and increasing the motor's moment of inertia  $J_0$  by addition of a flywheel.

Motors are designed to withstand the long starting times (2 ÷ 4 s) that progressive start entails.

For frequency of starting, see relevant paragraph.

The progressive start as above can be integrated by wiring a resistor in series to one or more phases, and switching-in during starting: **consult us if need be.**

### Haupteigenschaften der zweifach polumschaltbaren (50 Hz) Bremsmotoren (außer FV0)

### Main specifications of two-speed brake motors (FV0 excluded) (50 Hz)

Motorgröße Motor size	$J_0$ ≈ kg m <sup>2</sup> (2)	$Mf_{max}$ ≈ daN m (2) 3)	2.4-polig - poles - 2 800 . 1 400 min <sup>-1</sup> 1)			2.6-polig - poles - 2 800 . 900 min <sup>-1</sup> 1)			2.8-polig - poles - 2 800 . 710 min <sup>-1</sup> 1)			2.12-polig - poles - 2 800 . 450 min <sup>-1</sup> 1)		
			$P_1$ kW	$z_0$ (2) 4)	$M_{Anlauf - start.}$ $M_N$ ≈	$P_1$ kW	$z_0$ (2) 4)	$M_{Anlauf - start.}$ $M_N$ ≈	$P_1$ kW	$z_0$ (2) 4)	$M_{Anlauf - start.}$ $M_N$ ≈	$P_1$ kW	$z_0$ (2) 4)	$M_{Anlauf - start.}$ $M_N$ ≈
<b>63 A</b>	0,0003	0,175	0,18 0,12	4 000 6 300	3 2,9	—	—	—	—	—	—	—	—	—
<b>63 B</b>	0,0003	0,35	0,25 0,18	2 800 5 300	3 2,9	—	—	—	—	—	—	—	—	—
<b>63 C</b>	0,0004	0,175	—	—	—	—	—	—	0,18 0,045	11 200 22 400	1,4 1,7	—	—	—
<b>71 A</b>	0,0010	0,25	0,25 0,18	2 800 5 300	2,7 2,4	0,18 0,065	9 000 19 000	2,6 3	0,18 0,045	9 000 22 400	2,6 3	—	—	—
<b>71 B</b>	0,0012	0,50	0,37 0,25	2 800 5 300	2,6 2,4	0,25 0,095	7 100 14 000	2,3 2,7	0,25 0,06	7 100 17 000	2,3 2,8	—	—	—
<b>71 C</b>	0,0013	0,50	0,55 0,37	2 360 4 250	2,4 2,2	0,37 0,14	6 700 13 200	2,1 3,2	0,37 0,09	6 000 14 000	2,1 3,5	—	—	—
<b>80 A</b>	0,0028	1,1	0,55 0,37	2 360 4 250	2 2,2	0,37 0,14	4 000 10 600	2,4 2,1	0,37 0,09	3 550 11 800	2,4 2,5	0,3 0,045	4 000 9 000	2,5 2,4
<b>80 B</b>	0,0033	1,1	0,75 0,55	2 000 3 550	2,4 2,3	0,55 0,21	3 000 9 000	2,2 2	0,55 0,13	2 650 11 200	2,2 2	0,45 0,07	3 000 8 000	2,4 2,4
<b>80 C</b>	0,0033	1,1	1,1 0,75	1 600 2 800	2,5 2,6	0,75 0,3	2 240 6 700	2,4 1,9	0,75 0,18	2 360 10 000	2,4 1,7	—	—	—
<b>90 S</b>	0,0033	1,1	1,1 0,75	1 600 2 800	2,5 2,6	0,75 0,3	2 240 6 700	2,4 1,9	0,75 0,18	2 360 10 000	2,4 1,7	—	—	—
<b>90 L</b>	0,0039	1,1	—	—	—	—	—	—	0,92 0,22	1 900 9 000	2,4 2,3	—	—	—
<b>90 LA</b>	0,0048	1,6	1,5 1,1	1 180 2 000	2,9 2,9	1,1 0,42	1 900 5 300	2,6 2,2	1,1 0,28	1 700 7 500	2,6 2,4	0,75 0,11	2 240 7 500	2,4 2,2
<b>90 LB</b>	0,0052	2,7	2,2 1,5	1 000 1 700	2,9 2,9	1,5 0,55	1 600 4 000	2,4 2,3	1,5 0,37	1 600 6 000	2,4 1,9	1,1 0,15	1 700 6 000	2,4 2
<b>100 LA</b>	0,0069	2,7	2,2 1,5	1 060 1 800	2,4 2,6	1,5 0,55	1 600 4 000	2,5 2,2	1,5 0,37	1 600 5 600	2,5 2,7	1,5 0,21	1 600 4 500	2,5 2,2
<b>100 LB</b>	0,0075	4	3 2,2	800 1 320	2,4 2,6	1,85 0,75	1 500 3 550	2,4 2,4	1,85 0,45	1 500 5 000	2,4 2,6	1,85 0,27	1 500 4 000	2,4 1,7
<b>112 MA</b>	0,0097	5	4 3	710 1 180	2 2	2,2 0,9	1 400 3 150	2,6 2,2	2,2 0,55	1 400 4 500	2,6 2,2	2,2 0,33	1 400 3 750	2,6 1,8
<b>112 MB</b>	0,0103	5	4,8 3,6	670 1 120	2,2 2,3	3 1,1	1 320 3 000	2,2 2,3	3 0,75	1 320 4 000	2,2 2,2	3 0,42	1 320 3 550	2,2 1,9
<b>132 S</b>	0,0235	7,5 <sup>5)</sup>	6 4,5	630 1 120	2 2	4 1,5	1 120 2 120	2,6 2,9	4 1,1	1 120 3 150	2,6 2,2	4 0,63	1 120 2 800	2,6 2
<b>132 SB</b>	0,0178	7,5	7,5 5,8	500 800	2,5 2,4	—	—	—	—	—	—	—	—	—
<b>132 MA</b>	0,0283	10	9,2 7,1	475 800	2,5 2,6	5,5 2,2	800 1 900	2,9 2,2	5,5 1,5	800 2 500	2,9 2,3	5,5 0,9	800 2 360	2,9 1,5
<b>132 MB</b>	0,0346	15	11 8,5	450 750	2,2 2,2	7,5 3	750 1 800	2,8 2,1	7,5 2,1	710 2 120	2,8 1,9	7,5 1,2	710 1 800	2,8 1,4

1) Motordrehzahlen, anhand derer die Getriebemotordrehzahlen  $n_2$  bestimmt wurden.

2) Massenträgheitsmoment  $J_0$ , Bremsmoment  $Mf$ , Schalzhäufigkeit bei Leerlauf  $z_0$  [Sch./h] sind nur für Bremsmotor gültig.

3) Normalerweise sind die Motoren auf ein kleineres Bremsmoment eingestellt (s. **gesonderte Unterlage**).

4) Wenn der Anlauf bei Niederdrehzahl und anschließender Umschaltung auf Hochdrehzahl erfolgt, ist der  $z_0$ -Wert mit der niedrigen Polarität mit 2 (2.4-polig), 1,8 (2.6-polig), 1,4 (2.8-polig), und 1,25 (2.12-polig) zu multiplizieren.

5) Für 2.6, 2.8, 2.12-polige Motoren: 15 daN m.

1) Motor speed on the basis of which the gearmotor speeds  $n_2$  have been calculated.

2) Moment of inertia  $J_0$ , braking torque  $Mf$ , no-load starting frequency  $z_0$  [starts/h] valid for brake motors, only.

3) Motor is usually supplied with lower braking torque setting (see **specific literature**).

4) Where starting is at low speed with subsequent switch to high speed, the  $z_0$  value for the lower set of poles is to be multiplied by 2 (2.4 poles), 1,8 (2.6 poles), 1,4 (2.8 poles), 1,25 (2.12 poles).

5) For 2.6, 2.8, 2.12 poles motor: 15 daN m

## 2 - Eigenschaften

Für «**leichte**» **Fahrertriebe**<sup>1)</sup> ist als Alternative ein **HFV**-Bremsmotor (vor der Bestellbezeichnung ist HFV anzugeben) **mit Gs-Sicherheits- und/oder Standbremse** (Größen 63 ... 132), für die **maximale Anwendungswirtschaftlichkeit** zur Verfügung.

Die progressiven Anläufe und Anhalten sind durch die Anwesenheit des Kühlungsflüters aus Gusseisen (höheres Trägheitsmoment  $J_b$ , s. spezifische Dokumentation) und eines mäßigen (nicht einstellbaren, normalerweise  $M_f \approx M_N$ ) Bremsmoments gewährleistet.

Der Motorraumbedarf ist sehr reduziert und fast gleich die Abmessungen eines Motors in normaler Ausführung, deren elektromagnetische Bemessung unverändert bleibt.

**Für Betrieb mit Frequenzrichter geeignet:** Reichliche elektromagnetische Dimensionierung, Elektroblech mit niedrigen Verlusten, Phasentrennung, usw.

Für Einphasen-Versorgung und für Sonderausführungen: «Fremdaxiallüfter», «Drehgeber» und «Fremdaxiallüfter und Drehgeber» geeignet.

Bei anderen Eigenschaften und Details s. **gesonderte Unterlagen**.

Das progressive Anhalten erhält man durch die Mehrenergie des Motors (infolge hohen Trägheitsmomentes) mit Verlängerung der Anhaltzeit sowie durch ein Bremsmoment immer im richtigen Verhältnis zum Moment des Motors (mit der Möglichkeit im Bedarfsfall reduziert zu werden).

Vorgesehene zweifach polumschaltbare Motoren: **2.4, 2.6, 2.8, 2.12** -polig.

Zweifach polumschaltbare Motoren haben:

- Einzelspannung 400 V 50 Hz und Direkteinschaltung;
- DAHLANDER-Einzelwicklung: 2.4-polig;
- zwei getrennte Wicklungen: 2.6, 2.8, 2.12-polig;
- Anläufe bei niedriger Drehzahl mit folgender Umschaltung zu hoher Drehzahl.

Bei Umschaltung von Hoch- auf Niederdrehzahl und schwachen, keinen bzw. negativen Widerstandsmomenten, **bitte rückfragen**.

<sup>1)</sup> Mechanismusgruppe M 4 (max 180 Anläufe/Stunde) und Vollastbetrieb L 1 (leicht) oder L 2 (mäßig) nach ISO 4301/1, F.E.M./II 1997.

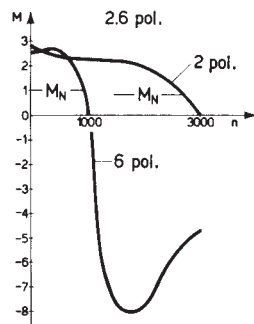
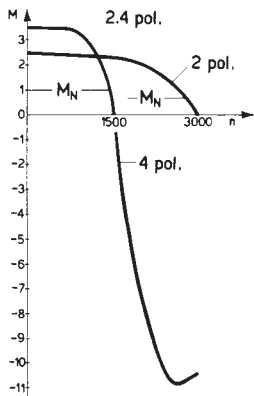

## 2 - Specifications

Für «**light**» **traverse movements**<sup>1)</sup> it is possible to have as alternative a brake motor type **HFV** (designation prefix) with d.c. **safety and/or parking brake** (sizes 63 ... 132), for **maximum application economy**.

The progressive starts and stops are granted by the presence of a cast iron cooling fan (higher moment of inertia  $J_b$ , see specific documentation) and by a smooth braking torque (not adjustable, usually  $M_f \approx M_N$ ).

Very reduced motor overall dimensions, nearly the same of a standard motor of which the electromagnetic dimensioning keeps unchanged.

**Suitable for the running with inverter:** generous electromagnetic sizing, low-loss electrical stamping, phase separators, etc..

Also available for single-phase supply and with following non -standard designs: «Axial independent cooling fan», «Encoder» and «Axial independent cooling fan and econdor».

For other specifications and details see **specific documentation**.

Progressive stop is obtained as a result of the greater energy which the motor possesses (due to increased moment of inertia) which prolongs the stopping time, and by a braking torque always proportioned to motor torque and with the possibility to be decreased when necessary.

Two-speed motors envisaged: **2.4, 2.6, 2.8, 2.12** poles.

Two-speed motors have:

- single voltage rating of 400 V 50 Hz, direct on-line starting;
- single DAHLANDER winding for 2.4 poles;
- separate windings for 2.6, 2.8, 2.12 poles;
- low speed start with subsequent switch to high speed run.

In those cases where switch from high to low speed is accompanied by low, non-existent or negative resisting torque, **consult us**.

<sup>1)</sup> Mechanism group M 4 (max 180 starts/h) and on-load running L 1 (light) or L 2 (moderate) to ISO 4301/1, F.E.M./II 1997.

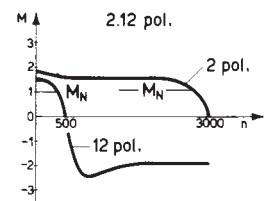
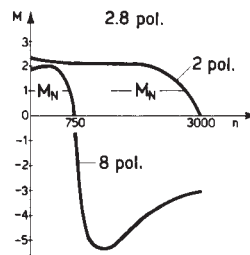

### Kurzzeitbetrieb (S2) und Aussetzbetrieb (S3); Betriebsarten S4 ... S10

Bei Betriebsarten S2 ... S10 kann die Motorleistung gemäß folgender Tabelle erhöht werden; das Anlaufdrehmoment bleibt un-verändert.

**Kurzzeitbetrieb (S2).** – Betrieb bei gleichmäßiger Belastung einer bestimmten Dauer, die jedoch nicht genügend lang ist, damit das Wärmegleichgewicht hergestellt wird. Daran schließt sich eine Stillstandzeit an, in der sich der Motor auf die Umgebungstemperatur abkühlen kann.

**Aussetzbetrieb (S3).** – Betriebsart, in welcher eine Reihe identischer Takte abläuft. Sämtliche Takte beinhalten eine Betriebszeit bei gleichmäßiger Belastung und eine Stillstandzeit. Weiterhin, dürfen in dieser Betriebsart die Stromspitzenwerte beim Anlauf die Motorenwärmung nur geringfügig beeinflussen.

$$\text{Einschaltdauer} = \frac{N}{N + R} \cdot 100\%$$

wobei:  $N$  die Betriebszeit bei gleichmäßiger Belastung ist,  
 $R$  die Stillstandzeit und  $N + R = 10$  min (falls höher, rückfragen) sind.

### Short time duty (S2) and intermittent periodic duty (S3); duty cycles S4 ... S10

In case of a duty-requirement type S2 ... S10 the motor power can be increased as per the following table; starting torque remains unchanged.

**Short time duty (S2).** – Running at constant load for a given period of time less than that necessary to reach normal running temperature, followed by a rest period long enough for motor's return to ambient temperature.

**Intermittent periodic duty (S3).** – Succession of identical work cycles consisting of a period of running at constant load and a rest period. Current peaks on starting are not to be of an order that will influence motor heat to any significant extent.

$$\text{Cyclic duration factor} = \frac{N}{N + R} \cdot 100\%$$

where:  $N$  being running time at constant load,  
 $R$  the rest period and  $N + R = 10$  min (if longer consult us).

Betrieb - Duty		Motorgröße <sup>1)</sup> - Motor size <sup>1)</sup>		
		63 ... 90	100 ... 132	160 ... 315
<b>S2</b>	Betriebsdauer	90 min	1	1,06
	duration of running	60 min	1	1,12
		30 min	1,12	1,18
		10 min	1,25	1,25
<b>S3</b>	Einschaltdauer	60%	1,12	
	cyclic duration factor	40%	1,18	
		25%	1,25	
		15%	1,32	
<b>S4 ... S10</b>		Rückfragen - consult us		

<sup>1)</sup> Für Motorgrößen 90LC 4, 112MC 4, 132MC 4 rückfragen.

<sup>1)</sup> For motor sizes 90LC 4, 112MC 4, 132MC 4, consult us.

## 2 - Eigenschaften

### Schalzhäufigkeit z

Bei direkter Einschaltung (bei einer max Anlaufzeit von  $0,5 \div 1$  s) soll die max Schalzhäufigkeit z 63 Sch./h bis Größe 90 (das gilt auch für **VO**), 32 Sch./h für die Größen 100 ... 132, 16 Sch./h für die Größen 160 ... 315 (für die Größen 160 ... 315 empfehlen wir die Stern-Dreieckschaltung).

Bremsmotoren: Doppelt so hohe Schalzhäufigkeit zugelassen (auch **FVO**), wie die oben angegebene bez. der normalen Motoren.

Oft wird bei Bremsmotoren (außer **FVO**) eine größere Schalzhäufigkeit z gefordert. In diesem Fall nachprüfen, ob:

$$z \leq z_0 \cdot \frac{J_0}{J_0 + J} \cdot \left[ 1 - \left( \frac{P}{P_1} \right)^2 \cdot 0,6 \right]$$

wobei:

$z_0, J_0, P_1$  in der Tabellen auf Seiten 12 und 13 angegeben sind;

J das auf die Motorachse bezogene Außenmassenträgheitsmoment in  $\text{kg m}^2$  ist (Getriebe, Kupplungen, angetriebene Maschine);

P [kW] der auf die Motorachse bezogene Leistungsbedarf der Maschine ist (der Wirkungsgrad wird daher berücksichtigt).

Falls der anlaufende Motor ein Widerstandsmoment überwinden muss, die Schalzhäufigkeit anhand folgender Formel überprüfen:

$$z \leq 0,63 \cdot z_0 \cdot \frac{J_0}{J_0 + J} \cdot \left[ 1 - \left( \frac{P}{P_1} \right)^2 \cdot 0,6 \right]$$

Bei zweifach polumschaltbaren Bremsmotoren (immer außer **FVO**) gilt für den Nachweis von z:

- Für die niedrige Polarität bei Anlauf bei Hochdrehzahl unter Berücksichtigung der jeweiligen Werte von  $z_0$  und  $P_1$ ;
- für beide Polaritäten bei Anlauf bei Niederdrehzahl und anschließender Umschaltung auf Hochdrehzahl unter Berücksichtigung der jeweiligen Werte von  $z_0$  und  $P_1$ , wobei der  $z_0$ -Wert der niedrigen Polarität mit 2 (2.4-polig), 1,8 (2.6-polig), 1,4 (2.8-polig), 1,25 (2.12-polig) zu multiplizieren ist.

Im Falle mangelhafter Ergebnisse oder hypersynchroner Abbremsungen (Umschaltung von Hoch- auf Niederdrehzahl) läßt sich der Nachweis mit erweiterten und detaillierten Formeln führen: **Bitte rückfragen**.

### Frequenz 60 Hz

Die **Normalmotoren** bis Größe 132 mit 50 Hz-Wicklung können mit 60 Hz versorgt werden: Die Drehzahl steigt um 20%. Wenn Anschlussspannung und Wicklungsspannung identisch sind, wenn höhere Übertemperaturen zugelassen werden und die Leistung nicht übermäßig ist, ergibt sich keine Leistungsänderung. Das Anlaufmoment und das Maximalmoment werden jedoch um 17% verringert. Ist die Anschlussspannung 20% höher als die Wicklungsspannung, dann steigt die Leistung um 20%, Anlauf- und Maximalmoment bleiben dabei unverändert.

Für **Bremsmotoren**, s. **gesonderte Unterlage**.

Ab Größe 160 – für Normal- und Bremsmotoren – empfiehlt sich eine 60 Hz Wicklung, weil somit auch der 20%-ige Leistungsanstieg genutzt werden kann.

### Spezifische Normen:

- Nennleistungen und -abmessungen nach CENELEC HD 231 (IEC 72-1, CNR-CEI UNEL 13117-71 und 13118-71, DIN 42677, NF C 51-120, BS 5000-10 und BS 4999-141) für Bauformen IM B5, IM B14 und deren Ableitungen;
- Nennleistungen und Betriebseigenschaften nach CENELEC EN 60034-1 (IEC 34-1, CEI EN 60034-1, DIN VDE 0530-1, NF C51-111, BS EN 60034-1);
- Schutzarten nach CENELEC EN 60034-5 (IEC 34-5, CEI 2-16, DIN EN 60034-5, NF C51-115, BS 4999-105);
- Bauformen nach CENELEC EN 60034-7 (IEC 34-7, CEI EN 60034-7, DIN IEC 34-7, NF C51-117, BS EN 60034-7);
- Schallpegel nach CENELEC 60034-9 (IEC 34.9, DIN 57530 pt. 9);
- Auswuchten und Vibrationsgeschwindigkeit (Vibrationsgrad nach Normklasse N) nach CENELEC HD 53.14 S1 (IEC 34-14, ISO 2373 CEI 2-23, BS 4999-142); die Motoren werden mit im Wellenende eingesteckter halber Passfeder ausgewuchtet;
- Kühlung nach CENELEC EN 60034-6 (CEI 2-7, IEC 34-6): Standardtyp IC 411; Typ IC 416 für Sonderausführung mit Fremdaxiallüfter.

## 2 - Specifications

### Frequency of starting z

As a general rule, the maximum permissible frequency of starting z for direct on-line start (maximum starting time  $0,5 \div 1$  s) is 63 starts/h up to size 90 (also valid for **VO**), 32 starts/h for sizes 100 ... 132 and 16 starts/h for sizes 160 ... 315 (star-delta starting is advisable for sizes 160 .. 315).

Brake motors can withstand a starting frequency double that of normal motors as described above **FVO** included).

A greater frequency of starting z is often required for brake motors (**FVO** excluded). In this case it is necessary to verify that:

where:

$z_0, J_0, P_1$  are shown in the tables at pages 12 and 13;

J is the external moment of inertia (of mass) in  $\text{kg m}^2$ , (gear reducers, couplings, driven machine) referred to the motor shaft;

P is the power in kW absorbed by the machine referred to the motor shaft (therefore taking into account efficiency).

If during starting the motor has to overcome a resisting torque, verify the frequency of starting by means of the following formula:

For two-speed brake motors (**FVO** always excluded) z must be verified:

- for the lower set of poles if starting is at high speed, taking into account relative  $z_0$  and  $P_1$  values;
- for both sets of poles, if starting is at low speed with subsequent switch to high speed, taking into account relative  $z_0$  and  $P_1$  values, though multiplying the  $z_0$  value for the lower set of poles by 2 (2.4 poles), 1,8 (2.6 poles), 1,4 (2.8 poles), 1,25 (2.12 poles).

Where results are unsatisfactory or where hypersynchronous braking occurs (switching from high to low speed), more complex and detailed verification formulae can be utilized: **consult us**.

### Frequenz 60 Hz

**Normal** motors up to size 132 wound for 50 Hz can be fed at 60 Hz; in this case speed increases by 20%. If input-voltage corresponds to winding voltage, power remains unchanged, providing that higher temperature rise values are acceptable and that the power requirement is not unduly demanding, whilst starting and maximum torques decrease by 17%. If input-voltage is 20% higher than winding voltage, power increases by 20% whilst starting and maximum torques keep unchanged.

For **brake** motors, see **specific literature**.

From size 160 upwards motors – both standard and brake ones – should be wound for 60 Hz exploiting the 20% power increase as a matter of course.

### Specific standards:

- nominal powers and dimensions to CENELEC HD 231 (IEC 72-1, CNR-CEI UNEL 13117-71 and 13118-71, DIN 42677, NF C 51-120, BS 5000-10 and BS 4999-141) for mounting positions IM B5, IM B14 and derivatives;
- nominal performances and running specifications to CENELEC EN 60034-1 (IEC 34-1, CEI EN 60034-1, DIN VDE 0530-1, NF C51-111, BS EN 60034-1);
- protection to CENELEC EN 60034-5 (IEC 34-5, CEI 2-16, DIN EN 60034-5, NF C51-115, BS 4999-105);
- mounting positions to CENELEC EN 60034-7 (IEC 34-7, CEI EN 60034-7, DIN IEC 34-7, NF C51-117, BS EN 60034-7);
- sound levels to CENELEC 60034-9 (IEC 34.9, DIN 57530 pt. 9);
- balancing and vibration velocity (vibration under standard rating N) to CENELEC HD 53.14 S1 (IEC 34-14, ISO 2373 CEI 2-23, BS 4999-142); motors are balanced with half key inserted into shaft extension;
- cooling to CENELEC EN 60034-6 (CEI 2-7, IEC 34-6): standard type IC 411; type IC 416 for non-standard design with axial inde-

### 3 - Bezeichnung

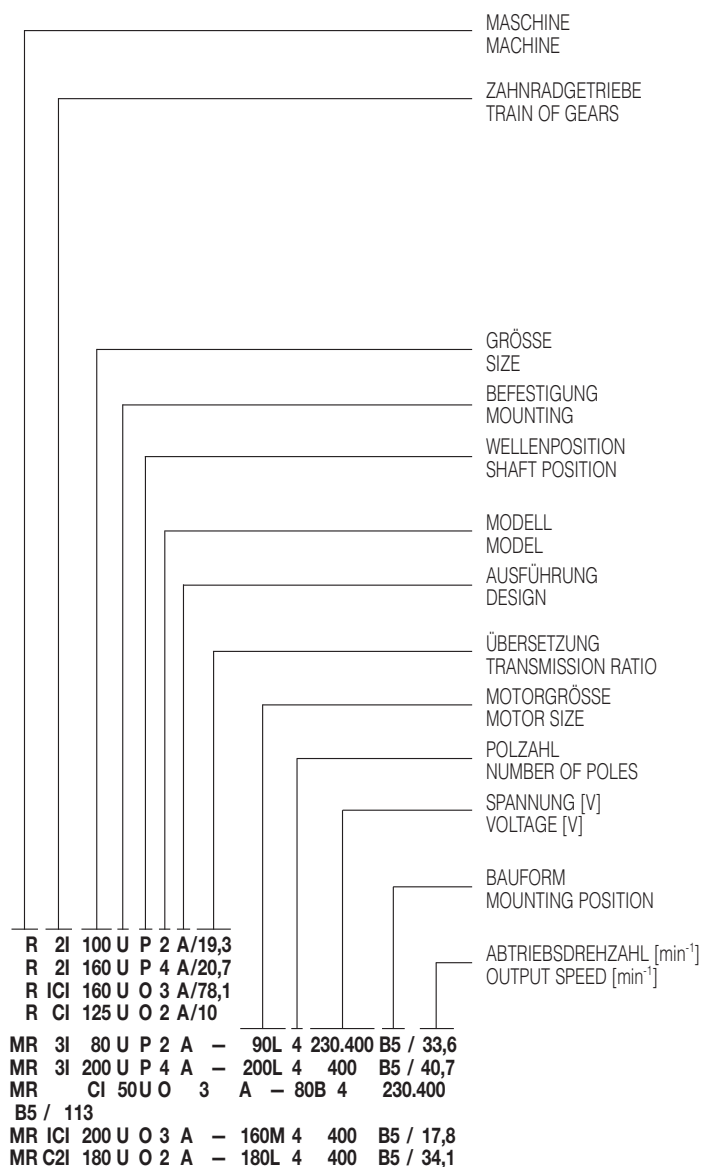

In den ▲, ♀, Ⓞ gekennzeichneten Fällen (Kap. 7, 8, 9, 10, 13, 16) und auch bei Bedarf der zusätzlichen Kühlung, ist die Bezeichnung mit Angaben der **Antriebsdrehzahl**  $n_1$ , sofern größer als 1 400  $\text{min}^{-1}$  bzw. kleiner als 355  $\text{min}^{-1}$  und der Bauform zu ergänzen, wenn dieselbe von **B3<sup>1)</sup>** abweicht.

z.B.: R ICI 125 UO3A/50 **Bauform V5**  
 MR 2I 80 UP2A - 100LA 4 230.400 B5/67,2 **Bauform B6**  
 R I 125 UP2A/2,53 **Bauform V6**,  $n_1 = 900 \text{ min}^{-1}$   
 R CI 360 UO2V/16  $n_1 = 1800 \div 600 \text{ min}^{-1}$

Bei Bremsmotoren die Buchstaben **FO** vor Motorgröße setzen.

z.B.: MR ICI 200 UO3A - **FO** 160M 4 400 B5/17,8

Bei Bremsmotoren mit progressivem Anlauf die Buchstaben **FVO** vor Motorgröße setzen.

z.B.: MR CI 100 UO3A - **FVO** 112MB 2.8 400 B5/116 - 29,5

Wird der Motor vom Kunden beigestellt, Spannungsangabe auslassen und Bezeichnung mit dem Wortlaut **Motor von uns beigestellt** vervollständigen.

z.B.: MR 2I 140 UP2A - 180M 4 ... B5/71,3 **Motor von uns beigestellt**

Falls das Getriebe bzw. der Getriebemotor **anders** als in der oben angegebenen Bauart gewünscht wird, bitte ausführlich angeben (Kap. 22).

<sup>1)</sup> Die Bezeichnung der Bauform (s. Kap. 8, 10, 13, 16) ist der Einfachheit halber nur auf die Fußbefestigung bezogen, obschon es sich um Getriebe mit Universalbefestigung handelt (z.B.: Befestigung mit B14-Flansch und abgeleiteten Formen; Befestigung mit B5-Flansch und abgeleiteten Formen, s. Kap. 22).

### 3 - Designation

<b>R</b>	Getriebe	gear reducer
<b>MR</b>	Getriebemotor	garmotor
<b>I</b>	1 Stirnradpaar	1 cylindrical gear pair
<b>2I</b>	2 Stirnradpaare	2 cylindrical gear pairs
<b>3I</b>	3 Stirnradpaare	3 cylindrical gear pairs
<b>4I</b>	4 Stirnradpaare	4 cylindrical gear pairs
<b>CI</b>	1 Kegelradpaar und 1 Stirnradpaar	1 bevel and 1 cylindrical gear pair
<b>ICI, C2I</b>	1 Kegelradpaar und 2 Stirnradpaare	1 bevel and 2 cylindrical gear pairs
<b>C3I</b>	1 Kegelrad und 3 Stirnradpaare	1 bevel and 3 cylindrical gear pairs
<b>40 ... 360</b>	Enduntersetzungsachsabstand [mm]	final reduction centre distance [mm]
<b>U</b>	universal	universal
<b>P</b>	parallel	parallel
<b>O</b>	orthogonal	orthogonal
<b>2, 3</b>	normal (s. Kap. 8, 10, 13, 16)	standard (see ch. 8, 10, 13, 16)
<b>4</b>	lang (s. Kap. 8, 13)	long (see ch. 8, 13)
<b>A</b>	normal	standard
<b>...</b>	andere (s. Kap. 8, 10, 13, 16)	other (see ch. 8, 10, 13, 16)
<b>63A ... 315MC</b>		
<b>2 ... 6; 2.4 ... 2.12</b>		
<b>230.400</b>	Größe ≤ 132	size ≤ 132
<b>400</b>	Größe ≥ 160 oder polumschaltbare Motoren	size ≥ 160 or two speed motors
<b>B5</b>		
<b>B5R</b>	für einige Kombieinheiten (s. Kap. 13, 16)	for some combinations (see ch. 13, 16)

The designation is to be completed stating mounting position, though only if **different** from **B3<sup>1)</sup>**, **input speed**  $n_1$  if greater than 1 400  $\text{min}^{-1}$  or less than 355  $\text{min}^{-1}$ , in the cases marked with ▲, ♀, Ⓞ (ch. 7, 8, 9, 10, 13, 16), when forced cooling is required.

E.g.: R ICI 125 UO3A/50 **mounting position V5**  
 MR 2I 80 UP2A - 100LA 4 230.400 B5/67,2 **mounting position B6**  
 R I 125 UP2A/2,53 **mounting position V6**,  $n_1 = 900 \text{ min}^{-1}$   
 R CI 360 UO2V/16  $n_1 = 1800 \div 600 \text{ min}^{-1}$

Where brake motor is required, insert the letters **FO** before motor size.

E.g.: MR ICI 200 UO3A - **FO** 160M 4 400 B5/17,8

Where progressive start brake motor is required, insert the letters **FVO** before motor size.

E.g.: MR CI 100 UO3A - **FVO** 112MB 2.8 400 B5/116 - 29,5

Where motor is supplied by the Buyer, omit voltage and complete designation by adding **motor supplied by us**.

E.g.: MR 2I 140 UP2A - 180M 4 ... B5/71,3 **motor supplied by us**

In the event of a gear reducer or garmotor being required in a design **different** from those stated above, specify it in detail (ch. 22).

<sup>1)</sup> To make things easier, the designation of mounting position (see ch. 8, 10, 13, 16) is referred to foot mounting only, even if gear reducers are in universal mounting (e.g.: B14 flange mounting and derivatives; B5 flange mounting and derivatives, see ch. 22).



## 4 - Wärmeleistung $P_t$ [kW]

Die roten Werten in der Tabelle weisen die Nennwärmeleistung  $P_{tN}$ , (auch für die **lange** Version gültig) aus, welche diejenige Leistung ist, die am Getriebeantrieb bei Dauerbetrieb, max Antriebsdrehzahl  $n_1 \leq 1400 \text{ min}^{-1}$  (bei höheren Drehzahlen bitte rückfragen), max Umgebungstemperatur  $40^\circ\text{C}$ , max Höhe  $1000 \text{ m}$  und Luftgeschwindigkeit  $\geq 1,25 \text{ m/s}$  angewendet werden kann, ohne eine Öltemperatur  $95^\circ\text{C}$  zu überschreiten.

Zahnradgetriebe Train of gears		Getriebegröße - Gear reducer size													
		$P_{tN}$ kW													
		50	63, 64	80, 81	100	125	140	160	180	200	225	250	280	320, 321	360
Stirnradgetriebe Parallel shafts	<b>1</b>	–	11,2	17	25	37,5	50	56	80	90	125	140	200	224	315
	<b>2I</b>	5	7,5	11,2	17	25	28	37,5	42,5	60	67	95	106	150	170
	<b>3I</b>	–	–	–	–	–	21,2	28	31,5	45	50	71	80	112	125
Kegelstirnradgetriebe Right angle shafts	<b>CI</b>	4,75	7,1	10,6	16	23,6	31,5	35,5	50	56	80	90	125	140	200
	<b>ICI</b>	–	–	–	–	16	18	23,6	26,5	37,5	–	–	–	–	–
	<b>C2I</b>	–	–	–	–	–	21,2	28	31,5	45	50	71	80	112	125

**WICHTIG.** Bei Getrieben und Getriebemotoren mit  $\Psi$  (Kap. 8, 10, 13, 16) gekennzeichneten Größen und Bauformen ist  $P_{tN}$  mit **0,71** oder **0,85** zu multiplizieren. Bei Kegelstirnradgetrieben und -getriebemotoren mit beidseitiger schnelllaufender Welle ist  $P_{tN}$  mit **0,85** zu multiplizieren.

**Die Wärmeleistung  $P_t$  kann höher liegen als die beschriebene Nennwärmeleistung  $P_{tN}$ .** Es gilt die Formel  $P_t = P_{tN} \cdot ft$  wo  $ft$  der Wärmefaktor ist, dessen Werte im Verhältnis zu Kühlung, Antriebsdrehzahl, Umgebungstemperatur und Betriebsart stehen und die Tabelle entnommen werden können.

Wärmefaktor in Abhängigkeit von **Kühlung** und **Antriebsdrehzahl** (dieser Wert ist mit dem der untenliegenden Tabelle zu multiplizieren).

## 4 - Thermal power $P_t$ [kW]

Nominal thermal power  $P_{tN}$ , indicated in red in the table (also valid for **long** model), is that which can be applied at the gear reducer input when operating on continuous duty, with input speed  $n_1 \leq 1400 \text{ min}^{-1}$  (for higher speed, consult us), maximum ambient temperature of  $40^\circ\text{C}$ , max altitude  $1000 \text{ m}$  and air speed  $\geq 1,25 \text{ m/s}$ , without exceeding  $95^\circ\text{C}$  approximately oil temperature.

**IMPORTANT.** For gear reducers and gearmotors of size and mounting position marked with  $\Psi$  multiply  $P_{tN}$  by **0,71** or **0,85** (ch. 8, 10, 13, 16). For right angle shaft gear reducers and gearmotors with double extension high speed shaft multiply  $P_{tN}$  by **0,85**.

**Thermal power  $P_t$  can be higher than the nominal  $P_{tN}$**  described above, as per the following formula:  $P_t = P_{tN} \cdot ft$  where  $ft$  is the thermal factor depending on cooling system, input speed, ambient temperature and type of duty as indicated in the tables.

Thermal factor as dependent on **cooling system** and input **speed** (this value is to be multiplied by that given in the following table).

Kühlung Cooling system	$n_1$ [ $\text{min}^{-1}$ ]			
	710	900	1 120	1 400
<b>Eigen Natural</b>	1			
<b>Zusätzlich mit Lüfter<sup>1)</sup> Fan cooling<sup>1)</sup></b>	<b>Stirnradgetriebe mit 1 Lüfter Parallel shafts with 1 fan</b> <sup>2)</sup>			
	1,12	1,18	1,25	1,32
<b>Zusätzlich mit Kühlschlange Water cooling by coil</b>	<b>Kegelstirnradgetriebe. Stirnradgetriebe mit 2 Lüftern Right angle shafts. Parallel shafts with 2 fans</b> <sup>2)</sup>			
	1,25	1,4	1,6	1,8 <sup>3)</sup>
	2			

- 1) Bei gleichzeitigem Einsatz der Kühlschlange, Werte mit **1,8** multiplizieren.  
2) Lage, Aussehenmaß und Bauartnachprüfung s. Kap. 22.  
3) Gilt auch für dazu geeigneten elektrischen Lüfter (Einbau kundenseitig).

- 1) With simultaneous water cooling by coil, values are multiplied by **1,8**.  
2) For positions, dimensions and design verification see ch. 22.  
3) Value also valid for electric fan (installed by the Buyer).

Wärmefaktor in Abhängigkeit von **Umgebungstemperatur** und **Betriebsart**.

Max Umgebungs- temperatur $^\circ\text{C}$	Dauer- S1	Betrieb Intermittier-Belastung S3 ... S6 Einschaltdauer [%] bei 60 min Betrieb <sup>1)</sup>			
		60	40	25	15
		<b>40</b>	1	1,18	1,32
<b>30</b>	1,18	1,4	1,6	1,8	2
<b>20</b>	1,32	1,6	1,8	2	2,24
<b>10</b>	1,5	1,8	2	2,24	2,5

$$1) \frac{\text{Betriebszeit unter Belastung [min]}}{60} \cdot 100$$

Wird im Katalog die Nennwärmeleistung  $P_{tN}$  angegeben, muss es nachgeprüft werden, ob die Leistung  $P_1$  kleiner oder gleich der Wärmeleistung  $P_t$  ( $P_1 \leq P_t = P_{tN} \cdot ft$ ). Bei Bedarf zusätzliche Kühlung, und/oder Sonderschmiermittel, vorsehen.

Falls die Wärmenachprüfung nicht erfüllt würde, obwohl man über zusätzliche Kühlmittel verfügt, ist es möglich, eine unabhängige Kühleinheit mit **Wärmeaustauscher** (s. Kap. 22) einzubauen; bitte rückfragen.

Die Wärmeleistung braucht nicht berücksichtigt zu werden, wenn der Dauerbetrieb höchstens  $1 \div 3 \text{ h}$  währt (von den kleinen Getriebegrößen zu den großen), und sich daran genügend lange Stillstandzeiten (ca.  $1 \div 3 \text{ h}$ ) anschließen, damit im Getriebe wieder ca. die Umgebungstemperatur herrscht.

Bei max Umgebungstemperaturen über  $40^\circ\text{C}$  oder unter  $0^\circ\text{C}$ , bitte rückfragen.

Thermal factor as dependent on **ambient temperature** and type of **duty**.

Maximum ambient temperature $^\circ\text{C}$	continuous S1	Duty on intermittent load S3 ... S6 Cyclic duration factor [%] for 60 min running <sup>1)</sup>			
		60	40	25	15
		<b>40</b>	1	1,18	1,32
<b>30</b>	1,18	1,4	1,6	1,8	2
<b>20</b>	1,32	1,6	1,8	2	2,24
<b>10</b>	1,5	1,8	2	2,24	2,5

$$1) \frac{\text{Duration of running on load [min]}}{60} \cdot 100$$

Wherever nominal thermal power  $P_{tN}$  is indicated in the catalogue it should be verified that the applied power  $P_1$  is less than or equal to the  $P_t$  value ( $P_1 \leq P_t = P_{tN} \cdot ft$ ), making provision for forced cooling and/or special lubricants, if necessary.

Whenever the thermal verification should not be satisfied, in spite of the prearrangement of cooling systems, it is possible to install an independent cooling unit with a **heat exchanger** (see ch. 22); consult us.

Thermal power needs not be taken into account when maximum duration of continuous running time is  $1 \div 3 \text{ h}$  (from small to large gear reducer sizes) followed by rest periods long enough to restore the gear reducer to near ambient temperature (likewise  $1 \div 3 \text{ h}$ ).

In case of maximum ambient temperature above  $40^\circ\text{C}$  or below  $0^\circ\text{C}$  consult us.

## 4 - Wärmeleistung $P_t$ [kW]

Zusätzliche Kühlung mit Lüfter, jeweils bei Stirnradgetrieben und Kegelstirnradgetrieben.



In den Bauarten mit beidseitig vorstehender schnelllaufender Welle (... **D**, ... **H** und ... **R**) ist der Zugang zu beiden Wellenenden auch mit eingebautem Lüfter möglich: **Der Kunde ist für die Zurüstung der Unfallschutzvorrichtung zuständig (98/37/EWG).**

## 4 - Thermal power $P_t$ [kW]

Fan cooling for parallel and right angle shaft gear reducers, respectively.

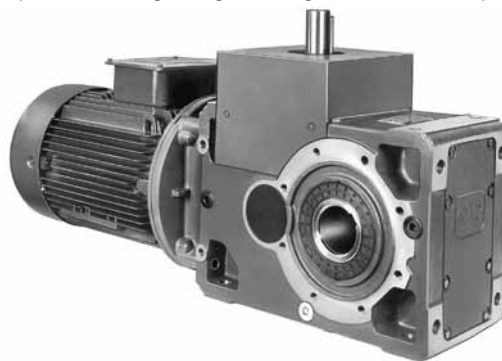

With double extension high speed shaft designs, (... **D**, ... **H** and ... **R**) both extensions are **accessible** even with fan fitted: **personal safety-guards are the Buyer's responsibility (98/37/CEE).**

## 5 - Betriebsfaktor $f_s$

Der Betriebsfaktor  $f_s$  bezieht sich auf die verschiedenen Betriebsbedingungen des Getriebes (Belastungen, Betriebsdauer, Schalthäufigkeit, Abtriebsdrehzahl  $n_2$ , u.a.) und ist daher bei Auswahl- und Nachprüfberechnungen unerlässlich.

Die im Katalog angegebenen Leistung und Drehmomente sind Nennwerte (das heißt, sie gelten für  $f_s = 1$ ) für die Getriebe und entsprechen dem angegebenen  $f_s$  für die Getriebemotoren.

**Betriebsfaktor in Abhängigkeit:** Von **Belastungsart** und **Betriebsdauer** (dieser Wert ist mit den daneben angegebenen Tabellenwerten zu multiplizieren).

**Service factor based:** on the **nature of load** and **running time** (this value is to be multiplied by the values shown in the tables alongside).

## 5 - Service factor $f_s$

Service factor  $f_s$  takes into account the different running conditions (nature of load, running time, frequency of starting, speed  $n_2$ , other considerations) which must be referred to when performing calculations of gear reducer selection and verification.

The powers and torques shown in the catalogue are nominal (i.e. valid for  $f_s = 1$ ) for gear reducers, corresponding to the  $f_s$  indicated for gearmotors.

... von der auf die Belastungsart bezogene **Schalthäufigkeit**.

... on **frequency of starting** referred to the nature of load.

... von der **Abtriebsdrehzahl  $n_2$** .

... on **output speed  $n_2$** .

Bez. Ref.	Belastungsart <sup>1)</sup> der angetriebenen Maschine Nature of load <sup>1)</sup> of the driven machine Beschreibung Description	Betriebsdauer [h] Running time [h]				
		6 300 2h/d	12 500 4h/d	25 000 8h/d	50 000 16h/d	80 000 24h/d
<b>a</b>	<b>Gleichmäßig</b> <b>Uniform</b>	0,8	0,9	1	1,18	1,32
<b>b</b>	<b>Mäßige Überbelastungen</b> (1,6 x normal) <b>Moderate overloads</b> (1,6 x normal)	1	1,12	1,25	1,5	1,7
<b>c</b>	<b>Heftige Überbelastungen</b> (2,5 x normal) <b>Heavy overloads</b> (2,5 x normal)	1,32	1,5	1,7	2	2,24

Belast. Bezug Load ref.	Schalthäufigkeit z [Sch./h] Frequency of starting z [starts/h]							
	2	4	8	16	32	63	125	250
<b>a</b>	1	1,06	1,12	1,18	1,25	1,32	1,4	1,5
<b>b</b>	1	1	1,06	1,12	1,18	1,25	1,32	1,4
<b>c</b>	1	1	1	1,06	1,12	1,18	1,25	1,32

$n_2$ min <sup>-1</sup>	
560 ÷ 355	1,25
355 ÷ 224	1,18
224 ÷ 140	1,12
140 ÷ 90	1,06
≤ 90	1

1) Zur Angabe der Belastungsart der angetriebenen Maschine gemäß Anwendung s. Tabelle auf Seite 20.  
1) For indication on the nature of load of the driven machine according to the application, see table on page 21

Erläuterungen und Betrachtungen zum Betriebsfaktor.

Die vorgenannten  $f_s$ -Werte gelten für:

- Elektromotor mit Käfigläufer, direkte Einschaltung bis 9,2 kW, Stern-Dreieck-Einschaltung für höhere Leistungen; für direkte Einschaltung bei Leistungen über 9,2 kW oder für Bremsmotoren muss der Betriebsfaktor  $f_s$  auf Grund einer doppelten Schalthäufigkeit als unter tatsächlichen Verhältnissen gewählt werden; bei Verbrennungsmotoren,  $f_s$  mit 1,25 (Mehrzylindermotor) oder mit 1,5 (Einzyliermotor) multiplizieren;
- Max Überbelastungsdauer 15 s, max Anlaufdauer 3 s; bei längerer Dauer u/o bei heftigen Stößen bitten wir um Rückfrage;
- eine Ganzzahl von Überbelast- oder Anlaufzyklen, die **nicht genau** in 1, 2, 3 oder 4 Umdrehungen der langsamlauf. Welle abgeschlossen werden; wenn das **genau** stattfindet, ist die Überbelastung als ständig wirkend zu betrachten;
- **normalen** Zuverlässigkeitsgrad; bei **erhöhten** Ansprüchen (schwierige Wartung, große Bedeutung des Getriebes für den Produktionsablauf, Unfallschutz usw.) ist  $f_s$  mit **1,25 ÷ 1,4** zu multiplizieren.

Motoren mit einem nicht über dem Nennmoment liegenden Anlaufmoment (Y-Δ-Einschaltung, bestimmte Gleichstrom- und Einphasenstromarten) und bestimmte Verbindungsarten des Getriebes an Motor und angetriebene Maschine (elastische, hydraulische, Schleuder-, Sicherheits- und Reibkupplungen, Riementriebe) üben einen günstigen Einfluss auf den Betriebsfaktor aus, weshalb in diesen Fällen auch unter erschwerten Betriebsbedingungen ein kleiner Betriebsfaktor angewandt werden kann. Im Bedarfsfall bitte rückfragen.

Details of service factor and considerations.

Given  $f_s$  values are valid for:

- electric motor with cage rotor, direct on-line starting up to 9,2 kW, star-delta starting for higher power ratings; for direct on-line starting above 9,2 kW or for brake motors, select  $f_s$  according to a frequency of starting double the actual frequency; for internal combustion engines multiply  $f_s$  by 1,25 (multicylinder) or 1,5 (single-cylinder);
- maximum time on overload 15 s; on starting 3 s; if over and/or subject to heavy shock effect, consult us;
- a whole number of overload cycles (or start) **imprecisely** completed in 1, 2, 3 or 4 revolutions of low speed shaft; if **precisely** a continuous overloads should be assumed;
- **standard** level of reliability; if a **higher** degree of reliability is required (particularly difficult maintenance conditions, key importance of gear reducer to production, personnel safety, etc.) multiply  $f_s$  by **1,25 ÷ 1,4**.

Motors having a starting torque not exceeding nominal values (star-delta starting, particular types of motor operating on direct current, and single-phase motors), and particular types of coupling between gear reducer and motor, and gear reducer and driven machine (flexible, centrifugal, fluid and safety couplings, clutches and belt drives) affect service factor favourably, allowing its reduction in certain heavy-duty applications; consult us if need be.

Anwendungslösungsbeispiele mit **langem Getriebemodell**.

Examples of applications which can make use of **long model** gear reducer.

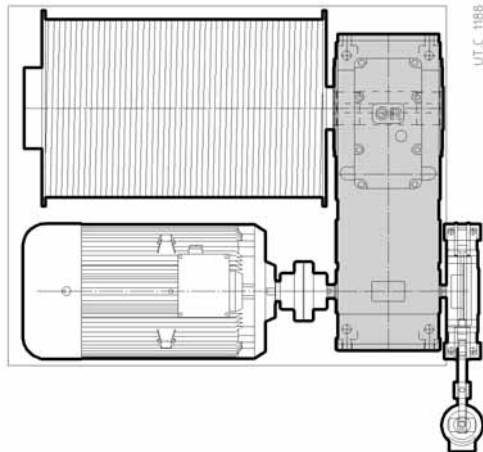
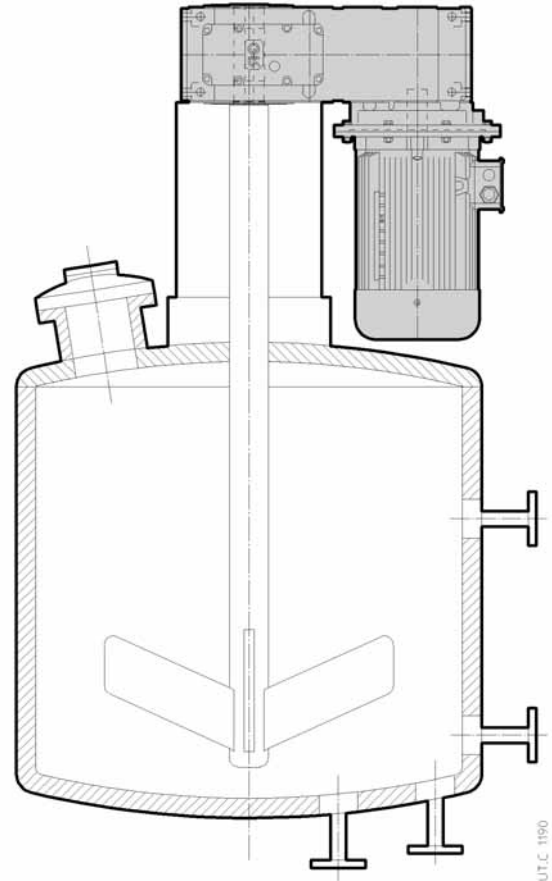
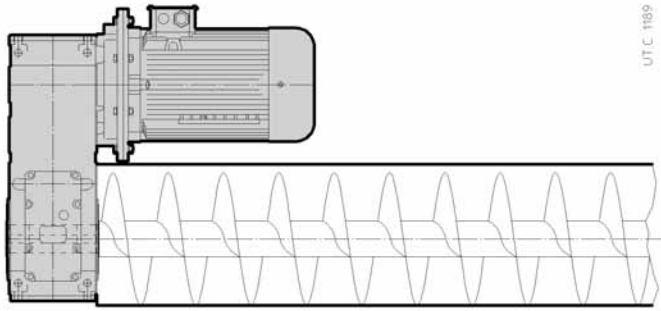

Andere Anwendungsbeispiele mit der neuen vorteilhaften Lösung der «**langen**» **Reihe**: Extruder, Pressen zur Kunststoffbearbeitung, Rührwerke, Belüfter, Förderer mit besonderen Raumbedarfserfordernissen, Mühle, Laufkrantranslation.

Other examples of applications that can take advantage of this innovative «**long**» **range** may be: extruders, injection presses for plastics, stirrers, aerators, conveyors with special dimension requirements, mills, bridge cranes.

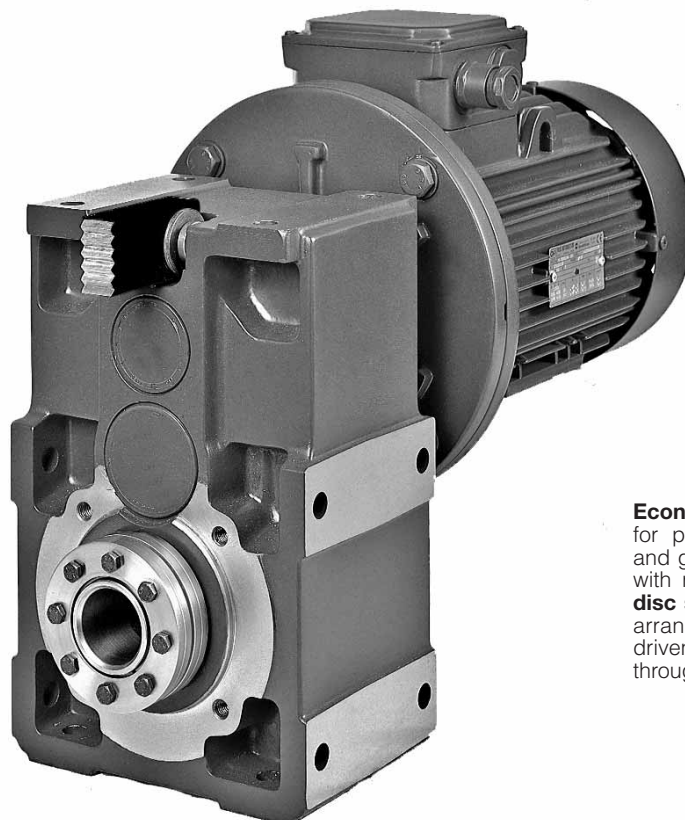

**Ökonomisches** Reaktionssystem für Stirnradgetriebe und -getriebemotoren Größen 40 ... 125, mit Aussparung und **Tellerfedersatz** zur Aufsteckbefestigung auf Maschinenzapfen oder Durchgangswelle.

**Economic** reaction arrangement for parallel shaft gear reducer and gearmotors sizes 40 ... 125, with reaction recess and **kit of disc springs**, for shaft mounting arrangement on shaft end of driven machine or on passing through shaft.

## 5 - Betriebsfaktor *f<sub>s</sub>*

### Belastungsartklassifizierung gemäß Anwendung

Anwendung	Bel. Bezug *	Anwendung	Bel. Bezug *	Anwendung	Bel. Bezug *
<b>Rühr- und Mischwerke</b> für Flüssiggut: – Mit konstanter Dichte – mit veränderlicher Dichte, suspendierten Feststoffen, erheblicher Viskosität Betonmischer, Mühlsteine, Wirbellöser <b>Beschickungs- und Dosierwerke</b> Rototypen (mit Rollen, Tisch, Segmenten) Band-, Schnecken- und Plattentypen Alternier- und Rütteltypen <b>Kompressoren</b> Kreiselkompressoren (einstufig, Mehrkamertypen) Kapselkompressoren (Zellenrad-, Nokken- und Schraubentypen) Axialkompressoren Kolbenkompressoren: – Mehrzylinder – Einzylinder <b>Höhenförderer</b> Bandtypen, mit Flieh- bzw. Schwerkraftentladung, Schneckenhebezug und Rolltreppen Becherwerke, Umlaufförderer, Hubräder, Lastaufzüge, Skips Aufzüge, mobile Gerüste, Beförderungsanlagen (Drahtseilbahnen, Sessellifts, Skillifts, Seilbahngondeln, usw.) <b>Förderanlagen und Naßbagger</b> Seilauflöser, Förderer, Pumpen, Winden (Betriebs- und Hilfszeug), Häufer, Abflusrräder Fräsköpfe, Verwitterungsanlagen, Förderanlagen (Bechertypen, mit Schaufelrädern, Frästypen) Fahrzeuge: – Auf Schiene – mit Ketten <b>Brecher und Granulatoren</b> Zuckerrohr, Gummi, Kunststoff, Mineralien, Steine <b>Krane, Winden und Regalförderer</b> Antrieb (Brücken, Stapler, Gabelgreifer) <sup>1)</sup> Armschwenkung Hub <sup>2)</sup> <b>Lebensmittelindustrie</b> Kochkessel (für Getreide und Malz), Mazerationsbottiche Aufschnittsmaschinen, Teigmaschinen, Fleischwolf, Schneiden (für Zuckerrüben), Schleudern, Schälmaschinen, Weinbereiter, Flaschenwaschanlagen, Kistenwaschgeräte, Korbwaschanlagen, Spülmaschinen, Einfüllmaschinen, Verschlussmaschinen, Kapselmaschinen, Ziehmaschinen, Kistenfüllmaschinen, Kistenentleermaschinen <b>Papierindustrie</b> Auf- und Abwickler, Saugzylinder, Trockner, Prägmaschinen, Bleichmaschinen, Muffenpressen, Streichwalzen, Papierwalzen, Massenauszieher Rühr- und Mischwerke, Strangpressmaschinen, Chipsbeschicker, Kalanders, Trocknungs- und Streckzylinder, Auflösehölländer, Waschmaschinen, Eindicker Schneidemaschinen, Zerkleinerer, Hochkalanders, Filzrüttler, Glättungsmaschinen, Pressen	 <b>a</b> <b>b</b> <b>c</b>  <b>a</b> <b>a, b</b> <b>c</b>  <b>a</b> <b>b</b> <b>b</b>  <b>b</b> <b>c</b>  <b>a, b</b>  <b>a, b</b>  <b>a, b</b>  <b>b</b>  <b>c</b>  <b>b</b>  <b>c</b>  <b>b</b>  <b>c</b>  <b>a, b</b>  <b>a, b</b>  <b>a, b</b>  <b>b</b>  <b>b</b>  <b>a, b</b>  <b>a</b>  <b>b</b>  <b>c</b>  <b>a</b>  <b>b</b>  <b>c</b>  <b>a</b>  <b>b</b>  <b>c</b>  <b>a</b>  <b>b</b>  <b>c</b>	<b>Holzindustrie</b> Mechaniklader, Palettenstapler Förderer für: – Platten, Späne, Ausschuss – Stämme Werkzeugmaschinen (Hobel, Fräsen, Ablängsägen, Schneiden, Zapfenschneidemaschinen, Sägen, Abkantmaschinen, Profilschneidemaschinen, Schleifmaschinen, Kalibrier- und Stainiermaschinen, usw.): – Vorschubsteuerung – Schnittsteuerung Rindenschälmaschinen: – mechanisch und hydrisch – mit Trommel <b>Erdölindustrie</b> Filter, Paraffinpressen, Kühltürme Rotary Bohrvorrichtungen, Pumpvorrichtungen <b>Textilindustrie</b> Kalander, Kardenmaschinen, Aufreißmaschinen, Trockner, Plüschmaschinen, Spinnmaschinen, Schlichtmaschinen, Abdichtmaschinen, Einseifmaschinen, Waschmaschinen, Mangeln, Bäummaschinen, Trockenbügler, Webstühle (Jacquard), Schärmaschinen, Spulmaschinen, Strickmaschinen, Färbmaschinen, Garnspulmaschinen, Zwirnmaschinen, Rauhaschinen, Schermaschinen <b>Maschinen für Tonbehandlung</b> Knetmaschinen, Strangpressmaschinen, Ausschlämmschaukelwerke Pressen (für Ziegel und Fliesen) <b>Maschinen für Gummi und Kunststoff</b> Strangpressmaschinen für: – Kunststoff – Gummi Mischwerke, Vorerhitzer, Kalander, Raffineure, Ziehnmaschinen, Walzwerke Mahlwerke, Knetmaschinen <b>Verpackungs- und Stapelmaschinen</b> Verpackungsmaschinen (Folie und Karton), Einwickelmaschinen, Umreifungsmaschinen, Etikettiermaschinen Palettisieranlagen, Depalettisiermaschinen, Stapler, Abstapler, Palettisierroboter <b>Werkzeugmaschinen für Metalle</b> Bohrmaschinen, Feilmaschinen, Hobler, Räummaschinen, Verzahnungsmaschinen, FMS, usw.: – Hauptsteuerungen (Schnitt und Vorschub) – Hilfssteuerungen (Werkzeugmagazin, Spannförderer, Bestücker) <b>Vorrichtungen</b> Schrittschalter, Schwingensteuerungen, Malteserkreuze, Parallelkurbel-Gelenkvierecke Kurbelgetriebe (Pleuel und Kurbel), Exzenter (Nocken und Stößel bzw. Nocken und Kipphebel) <b>Metallurgie</b> Schneiden: – Beschneiden, Abschöpfen, Köpfen – Bleche, Barren, Knüppel	 <b>a, b</b>  <b>b</b> <b>c</b>   <b>b</b> <b>c</b>  <b>b</b>  <b>c</b>  <b>b</b>  <b>c</b>  <b>b</b>  <b>c</b>  <b>a, b</b>  <b>a</b>  <b>b</b>  <b>c</b>  <b>a, b</b>  <b>a</b>  <b>b</b>  <b>c</b>  <b>b</b>  <b>c</b>  <b>a</b>  <b>b</b>  <b>c</b>  <b>a</b>  <b>b</b>  <b>c</b>  <b>a</b>  <b>b</b>  <b>c</b>  <b>a</b>  <b>b</b>	Querantriebsrollen, Drahtziehmaschinen, Wickler, Stückwender, Kettentriebe, Rollenrichtmaschinen, Rollenblechbiegemaschinen Schubvorrichtungen, Entzunderungsanlagen, Rohrschweißmaschinen, Walzstraßen, Walzwerken, Druckpressen, Knüppelschneidemaschinen, Schmiedehammer, Locher, Tiefziehmaschinen, Gewindeschneider, Richtmaschinen Rollgänge <b>Mühlen</b> Rotomühlen (mit Stäben, Walzen, Steinen oder Kugeln) Hammer-, Pendel-, Sprossen-, Schleuders-, Schlag- und Walzmühlen (Kugeln oder Rollen) <b>Pumpen</b> Kapsel- (Zahnrad-, Schrauben-, Flügelzellenpumpen) und Axialpumpen Kreispumpen: – Druckmedien konstanter Dichte – Druckmedien veränderlicher Dichte oder erheblicher Viskosität Dosierpumpen Kolbenpumpen: – Einfachwirkend ( $\geq 3$ Zylinder), doppelwirkend ( $\geq 2$ Zylinder) – einfachwirkend ( $\leq 2$ Zylinder), doppelwirkend einzylinder <b>Rototrommeln</b> Trockner, Kühler, Rotoöfen, Waschmaschinen Trommeln, Zementofen <b>Förderanlagen</b> Förderbänder (Kunststoff, Gummi, Metall) für: – Schüttgut feiner Körnung – Schüttgut grober Körnung oder Einzelgüter Riemen-, Platten-, Becher-, Leisten-, Pendel-, Rollen-, Schnecken-, Ketten-, Decken-, Montageförderer Förderer mit Mitnehmerelementen (Leisten, Kratzer, Ketten, Redler, usw.), mit Bodenketten und Speicherförderer Alternier- und Stroßförderer Elektrohängebahn - Getriebemotoren <b>Wasserbehandlung</b> Bioscheiben Entwässerungsschnecken, Schlammbletter, Rotoroste, Schlammverdicker, Vakuumfilter, anaerobische Digestoren Belüfter, Rotozylinder <b>Siebe und Rüttelsiebe</b> Luftreinigung, mobile Wasseranschlüsse Rotosiebe (Steine, Kies, Getreide) Siebe und Rüttelsiebe <b>Lüfter und Gebläse</b> mit kleinen Durchmessern (Fliehkraft- und Axialtypen) mit großen Durchmessern (Gruben, Ofen, usw.) Kühltürme (Künstlicher Zug), Turbolüfter, Rotokolbenventilatoren	

\* Der Belastungsbezug kann eventuell nach genauer Betriebskenntnis verändert werden.

1) Beim Verfahren der Brückenkrane wird normalerweise  $f_s > 1,6$  und der Umschlagkrane (Containerrangieren)  $f_s > 2$  angesetzt.

2) Zur Wahl von  $f_s$  nach F.E.M./I-10.1987, bitte rückfragen.

3) S. Katalog S.

4) S. Beiblatt zu Katalog A.

## 5 - Service factor $f_s$

### Classification of nature of load according to application

Application	Load ref. *	Application	Load ref. *	Application	Load ref. *
<b>Stirrers and mixers</b> Liquids: – constant density – varying density, solids in suspension, high viscosity concrete mixers, mullers, flash mixers	a	<b>Lumber and woodworking industries</b> mechanical loaders, pallet stackers conveyors: – boards, chips, waste – logs	a, b	transverse drive rollers, draw benches, coilers, inverters, draglines, flattening rolls, bending rolls pushers, descaling equipment, pipe welders, mill roll train drives, rolling mills, forging presses, billet croppers, power hammers, punches, impact extruders, tapping machines, straightening presses roller ways	b
<b>Feeders and batchers</b> rotary (roller, table, sector) belt, screw, plate reciprocating, vibrator	a, b, c	machine tools (planing, cutting, cross-cut and re-sawing, tenoning, bevelling, moulding, sanding, sizing and scratch-brushing machinery etc.): – feed drive – cutter drive	b, c	<b>Mills</b> rotary (rod, roller, pebble, ball) hammer, pin crusher, centrifugal, impact, rolling (ball or roller)	c <sup>3)</sup>
<b>Compressors</b> centrifugal (single-stage, multi-stage) rotary (vane, lobe, screw) axial reciprocating: – multi-cylinder – single-cylinder	a, b, c	<b>Oil industry</b> paraffin filter presses, chillers rotary drilling equipment pumping equipment	b, c	<b>Pumps</b> rotary (gear, screw, lobe, vane) and axial centrifugal: – liquids, constant density – liquids, variable density or high viscosity proportioning reciprocating: – single acting ( $\geq 3$ cylinders), double acting ( $\geq 2$ cylinders) – single acting ( $\leq 2$ cylinders), double acting single cylinder	a, b
<b>Elevators</b> belt, centrifugal or gravity discharge, screw jacks, escalators bucket, arm and tray elevators, paddle wheel, hoists, skips man lifts, mobile scaffolding, passenger transport (cable cars, chair, ski, gondola lifts etc.)	a, b	<b>Textile industry</b> calenders, cards, pickers, dryers, nappers, spinners, slashers, pads, soapers, washers, mangles, tenter frames, looms (Jacquard), warping machines, winders, knitting machines, dyeing machines, twisting frames, gig mills, cutters	b	<b>Rotating drums</b> dryers, chillers, rotary kilns, washing machines tumblers, cement kilns	a, b, c
<b>Excavators and dredges</b> cable reels, conveyors, pumps, winches (manoeuvring and utility), stackers, draining wheels cutter head drives, cutters, excavators (bucket ladder, paddle wheel, cutter) vehicles: – on rails – crawlers	a, b, c	<b>Clay working machinery</b> pug mills, extruders, rotary deslimers brick and tile presses	b, c	<b>Conveyors</b> belts (plastic, rubber, metal) for: – fine grade loose material – coarse grade loose material or discrete items belt, apron, bucket, slat, tray, roller, screw, chain, overhead rail, assembly drag (slat, flight, chain, Redler, etc.) ground level chain, flow accumulating reciprocating, shaker overhead power rail	a, b, c <sup>4)</sup>
<b>Crushers and granulators</b> sugar cane, rubber, plastics minerals, stone	b, c	<b>Rubber and plastics industries</b> extruders: – plastics – rubber mixing mills, warming mills, friction calenders, refiners, tubers and strainers, rolling mills crackers, masticators	b, c	<b>Sewage treatment</b> biological tanks (revolving disk) dewatering screws, collectors, rotary screens, thickeners, vacuum filters, anaerobic digestion tanks aerators, rotary breakers	a, b, c
<b>Cranes, winches and travelling lifts</b> travel (bridge, trolley, forks) <sup>1)</sup> slewing hoist <sup>2)</sup>	b, a, b	<b>Wrapping and stacking machinery</b> wrapping (film, cardboard), binding, strapping and labelling equipment palletizing/depalletizing and stacking/unstacking machinery, palletizing robots	a	<b>Screen and riddles</b> air washing, travelling water intake rotary (stone, gravel, cereals) vibrating screens, riddles, jigs	a, b, c
<b>Food industry</b> cookers (cereals and malt), mash tubs slicers, dough mixers, meat grinders, beet slicers, centrifuges, peelers, winemaking plant, bottle/bin/crate washers, rinsers, fillers, corks, cappers, extruders, crate filling and emptying equipment	a, b	<b>Engineering machine tools</b> boring, shaping, planing, broaching, gear cutting and FMS machines, etc.: – main drivers (cut and feed) – auxiliary drives (tools magazine, chip conveyor, workpiece infeed)	b, a	<b>Fans</b> small diameter (centrifugal, axial-flow) large diameter (mines, furnaces, etc.) cooling towers (inducted or forced draft), ducted, piston	a, b
<b>Paper mills</b> winders, suction rolls, dryers, embossing machinery, bleachers, press rolls, coating rolls, paper rolls, beaters, and pulpers agitators, mixers, extruders, chip feeders, calenders, felt dryers and stretchers, rag grinders, washers, thickeners cutters, chippers, calenders (super), felt whippers, glazing machines, presses	a, b, c	<b>Mechanisms</b> indexing, crank and slotted link, Maltese cross, articulated parallelogram rod and crank, cam control (cam and tappet, cam and rocker) <b>Metal mills</b> shears: – trimming, cropping, facing – for sheet/plate, ingots, billets	a, b, c		

\* Nature-of-load reference admits of modification where precise knowledge of duty is available.

1) In the traverse movement of the bridge usually it is necessary to have at least  $f_s > 1,6$  and in the storeyard cranes  $f_s > 2$  (container handling).

2) For selection of  $f_s$  to F.E.M./I-10.1987, consult us.

3) See cat. S.

4) See supplement to cat. A.

## 6 - Auswahl

### a - Getriebe

#### Bestimmung der Getriebegröße

- Die erforderlichen Angaben aufstellen: Die erforderliche Leistung  $P_2$  an der Getriebeabtriebswelle, Drehzahlen  $n_2$  und  $n_1$ , Betriebsbedingungen (Belastungsart, Dauer, Schalthäufigkeit  $z$ , andere Betrachtungen) mit Bezug auf Kap. 5.
- Den Betriebsfaktor  $f_s$  in Abhängigkeit von den Betriebsbedingungen bestimmen (Kap. 5).
- Die Getriebegröße (gleichzeitig, ebenso das Zahnradgetriebe und die Übersetzungen  $i$ ) in Abhängigkeit von  $n_2$ ,  $n_1$  und einer Leistung  $P_{N2}$  auswählen, die gleich oder größer als  $P_2 \cdot f_s$  sein soll (Kap. 7, 9).
- Die an der Getriebeantriebswelle erforderliche Leistung  $P_1$  mit Formel  $\frac{P_2}{\eta}$  berechnen, wobei  $\eta = 0,98 \div 0,92$  der Wirkungsgrad des Getriebes ist (Kap. 20).

Falls die Motornormierung ergibt, dass (unter Berücksichtigung des eventuellen Motor/Getriebe-Wirkungsgrades) die an der Getriebeantriebswelle angelegte Leistung  $P_1$  größer als die erforderliche Leistung ist, muss es sicher sein, dass die angelegte Mehrleistung niemals erfordert wird und dass die Schalthäufigkeit  $z$  so klein ist, dass der Betriebsfaktor nicht beeinflusst wird (Kap. 5).

Anderenfalls für die Auswahl ist  $P_{N2}$  mit  $\frac{P_1 \text{ angelegt}}{P_1 \text{ erfordert}}$  zu multiplizieren.

Die Berechnungen können anstatt von den Leistungen auch von den Drehmomenten ausgehen; bei kleinen  $n_2$ -Werten ist dies sogar vorzuziehen.

#### Nachprüfungen

- Anhand der in den Kapiteln 18 und 19 angeführten Anleitungen und Werte etwaige Radialbelastungen  $F_{r1}$ ,  $F_{r2}$  und Axialbelastung  $F_{a2}$  nachprüfen.
- Ist das Belastungsdiagramm aufgezeichnet und/oder verzeichnet man Überbelastungen – bedingt durch Anläufe unter voller Belastung (besonders für hohe Trägheiten und niedrige Übersetzungen), Abbremsungen, Stöße, Getriebe, in denen die langsamlaufende Welle durch die Trägheit der angetriebenen Maschine als Antrieb wirkt, andere statische oder dynamische Ursachen - darauf achten, dass der Spitzenwert des Drehmomentes (Kap. 20) stets unterhalb von  $2 \cdot M_{N2}$  liegt; falls es höher liegt oder nicht schätzbar ist, Sicherheitsvorrichtungen – bei den obengenannten Fällen – aufstellen, damit  $2 \cdot M_{N2}$  nicht übertreten wird.
- Nachprüfen, dass bei  $f_s < 1$  das Drehmoment  $M_2$  gleich oder kleiner als der bei  $n_1 \leq 90 \text{ min}^{-1}$  gültige Wert von  $M_{N2}$  ist (s. Seiten 33, 50).
- Die etwaige Notwendigkeit der zusätzlichen Kühlung nachprüfen, normalerweise bei Größen  $\geq 100$ , (Kap. 4 und 22).
- Für Getriebe mit Rücklaufsperrung – Größen 140, 180, 225, 280, 321, 360 – und bestimmten  $i_N$  bzw. niedrigen  $f_s$ -Werten, die Belastbarkeit der Rücklaufsperrung nach Tabellenwerten «Belastbarkeit der Rücklaufsperrung» (Kap. 22) nachprüfen.

#### Bestellbezeichnung

Bei der Bestellung ist die Getriebebezeichnung gem. Kap. 3 zu ergänzen, und zwar mit: Bauart, Bauform (nur falls von B3 abweichend) (Kap. 8 und 10); Antriebsdrehzahl  $n_1$ , sofern größer als  $1400 \text{ min}^{-1}$  bzw. kleiner als  $355 \text{ min}^{-1}$ , bei den  $\blacktriangle$ ,  $\Psi$ ,  $\diamond$  gekennzeichneten Fällen (Kap. 7, 8, 9, 10) und bei zusätzlicher Kühlung; eventuelle Sonderausführungen (Kap. 22).

z.B.: R 2l 100 UP2A/16,1 Bauform B7

R ICI 160 UO3A/78,1 abgestufte langsamlaufende Hohlwelle,  $n_1 = 1800 \text{ min}^{-1}$ .

### b - Getriebemotor

#### Bestimmung der Getriebemotorgröße

- Die erforderlichen Angaben aufstellen: Die erforderliche Leistung  $P_2$  an der Getriebemotorabtriebswelle, Drehzahl  $n_2$ , Betriebsbedingungen (Belastungsart, Betriebsdauer, Schalthäufigkeit  $z$ , andere Betrachtungen) mit Bezug auf Kap. 5.
  - Bei **Getriebemotoren für Fahrtriebe** ist es wichtig, bei der Ermittlung der erforderlichen Leistung  $P_2$  nicht übermäßig hohe Werte anzusetzen und das zu berücksichtigen (s. «Betrachtungen für die Auswahl»): Normalerweise wird die Motorleistung für Betrieb **S3** betrachtet.
  - Den Betriebsfaktor  $f_s$  bezogen auf die Betriebsbedingungen bestimmen (Kap. 5).
  - Die Getriebemotorgröße in Abhängigkeit von  $n_2$ ,  $f_s$  und einer Leistung  $P_1$  auswählen, die gleich oder größer als  $P_2$  sein soll (Kap. 11, 12, 14 und 15).
- Wenn  $P_2$  das Ergebnis einer genauen Berechnung ist, so ist der Getriebemotor in Abhängigkeit von einer Leistung  $P_1$  auszuwählen, die  $\geq \frac{P_2}{\eta}$  sein soll, wobei  $\eta = 0,96 \div 0,92$  der Wirkungsgrad des Getriebes ist (Kap. 20). Das Drehmoment  $M_2$  berücksichtigt bereits den Wirkungsgrad.

## 6 - Selection

### a - Gear reducer

#### Determining the gear reducer size

- Make available all necessary data: required output power  $P_2$  of gear reducer, speeds  $n_2$  and  $n_1$ , running conditions (nature of load, running time, frequency of starting  $z$ , other considerations) with reference to ch. 5.
- Determine service factor  $f_s$  on the basis of running conditions (ch. 5).
- Select the gear reducer size (also, the train of gears and transmission ratio  $i$  at the same time) on the basis of  $n_2$ ,  $n_1$  and of a power  $P_{N2}$  greater than or equal to  $P_2 \cdot f_s$  (ch. 7 and 9).
- Calculate power  $P_1$  required at input side of gear reducer using the formula  $\frac{P_2}{\eta}$ , where  $\eta = 0,98 \div 0,92$  is the efficiency of the gear reducer (ch. 20).

When for reasons of motor standardization, power  $P_1$  applied at input side of gear reducer turns out to be higher than the power required (considering motor/gear reducer efficiency), it must be certain that this excess power applied will never be required, and frequency of starting  $z$  is so low as not to affect service factor (ch. 5).

Otherwise, make the selection by multiplying  $P_{N2}$  by  $\frac{P_1 \text{ applied}}{P_1 \text{ required}}$ .

Calculations can also be made on the basis of torque instead of power; this method is even preferable for low  $n_2$  values.

#### Verifications

- Verify possible radial loads  $F_{r1}$ ,  $F_{r2}$  and axial load  $F_{a2}$  by referring to instructions and values given in ch. 18 and 19.
- When the load chart is available, and/or there are overloads – due to starting on full load (mainly for high inertias and low transmission ratios), braking, shocks, gear reducers in which the low speed shaft becomes driving member due to driven machine inertia, or other static or dynamic causes – verify that the maximum torque peak (ch. 20) is always less than  $2 \cdot M_{N2}$ ; if it is higher or cannot be evaluated in the above cases, install a safety device so that  $2 \cdot M_{N2}$  will never be exceeded.
- Verify, when  $f_s < 1$ , that torque  $M_2$  is less or equal to  $M_{N2}$  value valid for  $n_1 \leq 90 \text{ min}^{-1}$  (see pages 33 and 50).
- Verify, usually for sizes  $\geq 100$ , possible need for forced cooling (ch. 4 and 22).
- For gear reducers sizes 140, 180, 225, 280, 321, 360 with backstop device having particular  $i_N$  or low  $f_s$  values, verify load capacity of backstop device according to the values given in the table «Backstop device load capacity» (ch. 22).

#### Designation for ordering

When ordering give the complete designation of the gear reducer as shown in ch. 3. The following information is to be given: design and mounting position (only when different from B3) (ch. 8 and 10); input speed  $n_1$ , if greater than  $1400 \text{ min}^{-1}$  or less than  $355 \text{ min}^{-1}$  and for cases marked with  $\blacktriangle$ ,  $\Psi$ ,  $\diamond$  (ch. 7, 8, 9, 10) and when fan cooling is required; possible non-standard designs (ch. 22).

E.g.: R 2l 100 UP2A/16,1 mounting position B7

R ICI 160 UO3A/78,1 stepped hollow low speed shaft,  $n_1 = 1800 \text{ min}^{-1}$ .

### b - Gearmotor

#### Determining the gearmotor size

- Make available all necessary data: required output power  $P_2$  of gearmotor, speed  $n_2$ , running conditions (nature of load, running time, frequency of starting  $z$ , other considerations) with reference to ch. 5.
- In the case of **gearmotors for traverse movements** it is important when determining required power  $P_2$  not to overestimate, and to take into account starting torque (see «Considerations on selection»): usually consider motor power for **S3** duty.
- Determine service factor  $f_s$  on the basis of running conditions (ch. 5).
- Select the gearmotor size on the basis of  $n_2$ ,  $f_s$  and of a power  $P_1$  greater than or equal  $P_2$  (ch. 11, 12, 14 and 15).

If power  $P_2$  required is the result of a precise calculation, the gearmotor should be selected on the basis of a power  $P_1$  equal to or greater than  $\frac{P_2}{\eta}$ , where  $\eta = 0,96 \div 0,92$  is gear reducer efficiency (ch. 20). The torque value  $M_2$  has been calculated taking into account efficiency.

## 6 - Auswahl

Falls die Motornormierung ergibt, dass die verfügbare Leistung  $P_1$  im Katalog viel größer als die erforderliche Leistung  $P_2$  ist, so kann Getriebemotor nur dann in Abhängigkeit von einem kleineren Betriebsfaktor ( $fs \cdot \frac{P_2}{P_1}$ ) gewählt werden, wenn es ganz sicher ist, dass die verfügbare Mehrleistung unter kleinen Umständen erfordert wird und dass die Schalthäufigkeit z derart gering ist, dass der Betriebsfaktor nicht beeinflusst wird (Kap. 5).

Die Berechnungen können anstatt von den Leistungen auch von den Drehmomenten ausgehen; bei kleinen  $n_2$ -Werten ist dies sogar vorzuziehen.

### Nachprüfungen

- Anhand der in Kapitel 19 angeführten Anleitungen und Werte die etwaige Radial-  $F_{r2}$  und Axialbelastung  $F_{a2}$  nachprüfen.
- Für den Motor die Schalthäufigkeit z anhand der in Kap. 2b erteilten Anleitungen und Werte nachprüfen, falls sie oberhalb der normalerweise zulässigen Schalthäufigkeit liegt. Normalerweise ist diese Nachprüfung nur bei Bremsmotoren durchzuführen.
- Bei aufgestelltem Belastungsdiagramm und/oder Überbelastungen, – bedingt durch Anläufe unter voller Belastung (besonders für hohe Trägheiten und niedrige Übersetzungen), Abbremsungen, Stöße, Getriebe, in denen die langsamlaufende Welle durch die Trägheit der angetriebenen Maschine als Antrieb wirkt, andere statische oder dynamische Ursachen – darauf achten, dass der Spitzenwert des Drehmomentes (Kap. 20) stets unterhalb von  $2 \cdot M_{N2}$  ( $M_{N2} = M_2 \cdot fs$ , s. Kap. 11, 12, 14 und 15) liegt: Falls es höher liegt oder nicht schätzbar ist, Sicherheitsvorrichtungen – bei den obengenannten Fällen – aufstellen, damit  $2 \cdot M_{N2}$  nicht übertreten wird.
- Die etwaige Notwendigkeit der zusätzlichen Kühlung nachprüfen, normalerweise bei  $P_1 \geq 30$  kW, (Kap. 4 und 22).

### Bestellbezeichnung

Bei der Bestellung ist die Getriebemotorbezeichnung gem. Kap. 3 zu ergänzen und zwar mit: Bauart und Bauform des Getriebemotors (nur falls von B3 abweichend) (Kap. 13 und 16), Spannung und Bauform (B5 oder B5A oder B5R) des Motors; eventuelle Sonderausführungen (Kap. 22).

z.B.: MR 2l 80 UP2A - 112M 4 230.400 B5/89,4 Bauform V5  
MR CI 100 UO3D - F0 100LB 4 230.400 B5/46,5 2. Motorwellenende  
MR 3l 100 UP2A - FV0 100LA 2.8 400 B5/87,1 - 22,1 Bauform B8  
MR ICI 200 UO3A - 160L 4 400 B5/33,1 Rücklauf Sperre, Freidrehung lt. weißem Pfeil.

Wird der Motor vom Kunden beigestellt, Spannungsangabe auslassen und Bezeichnung vervollständigen mit: Motor von uns beigestellt.

z.B.: MR ICI 160 UO3A - 180M 4 ... B5/70,8 Motor von uns beigestellt.

Der kundenseitig beigestellte Motor muss den **UNEL-Normen** entsprechen, mit Präzisionspassungen (UNEL 13501-69) ausgeführt sein und **frei unser Werk** verschickt werden, wo er mit dem Getriebe gepaart wird.

## Betrachtungen für die Auswahl

### Motorleistung

Die Motorleistung muss unter Berücksichtigung des Wirkungsgrades des Getriebes und eventueller anderer Antriebe möglichst genau so groß wie die von der angetriebenen Maschine erforderliche Leistung sein, und ist daher möglichst genau zu bestimmen.

Die erforderliche Leistung der Maschine kann berechnet werden, während man vor Augen hält, dass die Leistung für die auszuführende Arbeit, die Reibungen (Anlaufgleit-, Gleit- und Wälzreibung), sowie die Trägheit (insbesondere wenn die Massen und/oder die Beschleunigung oder Verzögerung beträchtlich sind) aufgebracht werden soll. Die erforderliche Leistung der Maschine kann auch durch Versuche, durch Vergleich mit ausgeführten Anlagen, durch Strom- oder elektrische Leistungsmessungen versuchsweise festgelegt werden.

Bei überdimensioniertem Motor ergeben sich höhere Anzugsströme, so dass größere Sicherungen und Leiterquerschnitte erforderlich sind; die Betriebskosten steigen, da sich der Leistungsfaktor ( $\cos \varphi$ ) und der Wirkungsgrad verschlechtern; der Antrieb wird stärker beansprucht und es besteht Bruchgefahr, da er normalerweise auf die erforderliche Leistung der Maschine und nicht auf die Leistung des Motors ausgelegt ist.

Insbesondere ist es bei den **Getriebemotoren für Fahrtriebe (FV0-Motor)** wichtig – damit der progressive Anlauf nicht beeinträchtigt wird –, die installierte Leistung nicht übermäßig hoch i.V. mit der aufgenommenen anzusetzen; bei der Ermittlung **bitte unbedingt rückfragen**: Ein **spezifisches Berechnungsprogramm** erlaubt uns eine zuverlässige und rechtzeitige Antwort zu geben.

## 6 - Selection

When for reasons of motor standardization, power  $P_1$  available in catalogue is much greater than the power  $P_2$  required, the gearmotor can be selected on the basis of a lower service factor ( $fs \cdot \frac{P_2}{P_1}$ ) provided it is certain that this excess power available will never be required and frequency of starting z is low enough not to affect service factor (ch. 5).

Calculations can also be made on the basis of torque instead of power; this method is even preferable for low  $n_2$  values.

### Verifications

- Verify possible radial load  $F_{r2}$  and axial load  $F_{a2}$  referring to directions and values given in ch. 19.
- For the motor, verify frequency of starting z when higher than that normally permissible, referring to directions and values given in ch. 2b; this will normally be required for brake motors only.
- When a load chart is available, and/or there are overloads – due to starting on full load (especially with high inertias and low transmission ratios), braking, shocks, gear reducers in which the low speed shaft becomes driving member due to driven machine inertia, or other static or dynamic causes – verify that the maximum torque peak (ch. 20) is always less than  $2 \cdot M_{N2}$  ( $M_{N2} = M_2 \cdot fs$ , see ch. 11, 12, 14 and 15); if it is higher or cannot be evaluated in the above instances, install suitable safety devices so that  $2 \cdot M_{N2}$  will never be exceeded.
- Verify, usually for  $P_1 \geq 30$  kW, possible need for forced cooling (ch. 4 and 22).

### Designation for ordering

When ordering give the complete designation of the gearmotor as shown in ch. 3. The following information is to be given: design and mounting position of gearmotor (only if different from B3) (ch. 13 and 16), voltage and mounting position of motor (B5 or B5A or B5R); non-standard designs, if any (ch. 22).

E.g.: MR 2l 80 UP2A - 112M 4 230.400 B5/89,4 mounting position V5  
MR CI 100 UO3D - F0 100LB 4 230.400 B5/46,5 2<sup>nd</sup> motor shaft end  
MR 3l 100 UP2A - FV0 100LA 2.8 400 B5/87,1 - 22,1 mounting position B8  
MR ICI 200 UO3A - 160L 4 400 B5/33,1 backstop device white arrow free-rotation.

Where motor is supplied by the Buyer, do not specify voltage, and complete the designation with the words: motor supplied by us.

E.g.: MR ICI 160 UO3A - 180M 4 ... B5/70,8 motor supplied by us.

The motor supplied by the Buyer must be to **UNEL standards** with mating surfaces machined under accuracy rating (UNEL 13501-69) and is to be sent **carriage and expenses paid to our factory** for fitting to the gear reducer.

## Considerations on selection

### Motor power

Taking into account the efficiency of the gear reducer, and other drives – if any – motor power is to be as near as possible to the power rating required by the driven machine: accurate calculation is therefore recommended.

The power required by the machine can be calculated, seeing that it is related directly to the power-requirement of the work to be carried out, to friction (starting, sliding or rolling friction) and inertia (particularly when mass and/or acceleration or deceleration are considerable). It can also be determined experimentally on the basis of tests, comparisons with existing applications, or readings taken with amperometers or wattmeters.

An oversized motor would involve: a greater starting current and consequently larger fuses and heavier cable; a higher running cost as power factor ( $\cos \varphi$ ) and efficiency would suffer; greater stress on the drive, causing danger of mechanical failure, drive being normally proportionate to the power rating required by the machine, not to motor power.

In the particular case of **gearmotors for traverse movements (FV0 motor)** it is essential that rated power should not far exceed power consumption if progressive start is not to be compromised; with this in mind, **consult us every time** when determining: a **detailed programme of calculation** enables us to give a quick and reliable answer.

## 6 - Auswahl

Hierbei **muss** der Betrieb genauestens **bekannt sein**: Zeiten und Frequenz/h der Betriebszyklen, eventuell notwendige Beschleunigungen und Abbremsungen, Trägheiten, betriebs- und reibungsbedingte Belastungen. Fehlen diese Angaben, so **müssen** jedoch die Nachweisquellen zu deren Ermittlung vorhanden sein.

Höhere Motorleistungen sind nur erforderlich, wenn hohe Werte der Umgebungstemperatur, der Aufstellungshöhe, der Einschaltfrequenz oder anderer Bedingungen gefragt sind.

### Antriebsdrehzahl

Max Antriebsdrehzahl ist bez. des Zahnradgetriebes diejenige der ersten Tabelle (für die nicht angegebenen Zahnradgetriebe muss immer  $n_1 \leq 2\,800 \text{ min}^{-1}$  sein); bei Aussetzbetrieb oder bei Sondererfordernissen sind höhere Drehzahlen möglich; bitte rückfragen.

Bei  $n_1$  größer als  $1\,400 \text{ min}^{-1}$ , ändern sich die **Leistung** und das **Drehmoment** bei entsprechender Übersetzung, wie aus der nachfolgenden Tabelle ersichtlich. In diesem Falle sind Belastungen auf dem schnelllaufenden Wellenende zu vermeiden.

Bei veränderlicher  $n_1$  berücksichtigt man bei der Auswahl den Höchstwert von  $n_{1 \text{ max}}$ , die Auswahl jedoch auch bei  $n_{1 \text{ min}}$  nachprüfen.

Wenn zwischen Motor und Getriebe ein Riementrieb ist, sollten bei der Auswahl verschiedene  $n_1$  berücksichtigt werden, um die technisch und wirtschaftlich optimale Lösung zu finden. Der Katalog erleichtert diese Auslegung, weil in einer einzigen Spalte mehrere Antriebsdrehzahlen  $n_1$ , für eine bestimmte Abtriebsdrehzahl  $n_{N2}$  angegeben sind. Dabei ist stets zu beachten, dass – außer bei verschiedenen Anforderungen – die Antriebsdrehzahl niemals  $> 1\,400 \text{ min}^{-1}$  liegt, dagegen soll der Antrieb ausgenutzt werden und die Antriebsdrehzahl vorzugsweise  $< 900 \text{ min}^{-1}$  liegen.

### Zähnezahlverhältnis der Stirnradvorstufe

Es kann der Drehzahlberechnung der vorstehenden Zwischenwelle, Bauarten ... D (s. Kap. 8, 10, 13, 16) nützlich sein.

## 6 - Selection

In such cases, a detailed description of duty requirement **must be made available**: duration and frequency per hour of work cycle, acceleration and deceleration requirements if any, inertia, loads deriving from friction and work. In the absence of such data **it is essential** to provide all details which will permit their determination.

Only high values of ambient temperature, altitude, frequency of starting or other particular conditions require an increase in motor power.

### Input speed

Maximum input speed is, according to train of gears, the one stated in the first table (for unstated train of gears, it must be always  $n_1 \leq 2\,800 \text{ min}^{-1}$ ); for intermittent duty or for particular needs higher speeds may be accepted; consult us.

For  $n_1$  higher than  $1\,400 \text{ min}^{-1}$ , **power** and **torque** ratings relating to a given transmission ratio vary as shown in the second table. In this case no loads should be imposed on the high speed shaft end.

For variable  $n_1$ , the selection should be carried out on the basis of  $n_{1 \text{ max}}$ ; but it should also be verified on the basis of  $n_{1 \text{ min}}$ .

When there is a belt drive between motor and gear reducer, different input speeds  $n_1$  should be examined in order to select the most suitable unit from engineering and economy standpoints alike (our catalogue favours this selection as it shows a number of input speed values  $n_1$  relating to a determined output speed  $n_{N2}$  in the same section). Input speed should

not be  $> 1\,400 \text{ min}^{-1}$ , unless conditions make it necessary; better to take advantage of the transmission, and use an input speed  $< 900 \text{ min}^{-1}$ .

### Gear ratio of input cylindrical train of gears

This ratio may be useful when calculating the speed of the intermediate shaft extension for ... D designs (see ch. 8, 10, 13, 16).

Getriebe- größe Gear reducer size	Zähnezahlverhältnis der Stirnradvorstufe - Gear ratio of input cylindrical train of gears									
	Getriebe Gear reducers		Getriebemotoren - Gearmotors Motorgröße - Motor size							
	$i_N \leq 80$	$i_N \geq 100$	63, 71 B5R	71, 80 B5R	80, 90 B5R	90, 100 B5R, 112 B5R	100, 112, 132 B5R	132, 160 B5R	160, 180, 200 B5R	200, 225
3I 40	—	—	2,41	—	—	—	—	—	—	—
3I 50	—	—	2,59	1,89	—	—	—	—	—	—
3I 63, 64 ICI 40, 50	3,12	—	3,5	2,54	2,03	—	—	—	—	—
4I 63, 64 C3I 40,50	—	—	10,9	7,91	—	—	—	—	—	—
3I, ICI 80, 81 ICI 63, 64	3,18	—	—	3,18 (3,8) <sup>1)</sup>	2,54	2	—	—	—	—
4I, C3I 80, 81 C3I 63, 64	—	—	—	10,1 (12,1) <sup>1)</sup>	8,08	—	—	—	—	—
3I, ICI 100	3,18	6,38	—	—	3,18 (3,8) <sup>1)</sup>	2,54	2	—	—	—
4I, C3I 100	—	—	—	—	10,1 (12,1) <sup>1)</sup>	8,08	—	—	—	—
3I, ICI 125 ICI 140	3,13	6,36	—	—	—	3,13 (3,86) <sup>1)</sup>	2,54 (3,13) <sup>2)</sup>	2,03	—	—
4I, C3I 125	—	—	—	—	—	9,77 (12,1) <sup>1)</sup>	7,92	—	—	—
ICI 160, 180	3,17	6,38	—	—	—	—	3,17 (4) <sup>1)</sup>	2,56	2 (2,56) <sup>3)</sup>	—
ICI 200	3,17	6,38	—	—	—	—	—	3,17 (3,8) <sup>1)</sup>	2,56 (3,17) <sup>2)</sup>	2 (2,56) <sup>3)</sup>

1) Werte gültig für Zahnradgetriebe: 3I mit  $i_N \geq 100$ , ICI mit  $i_N \geq 100$ , 4I mit  $i_N \geq 315$ , C3I mit  $i_N = 400$ .

2) Werte gültig für Zahnradgetriebe: 3I mit  $i_N = 80$ , ICI mit  $i_N \geq 80$ .

3) Werte gültig für Zahnradgetriebe: ICI mit  $i_N \geq 63$ .

1) Values valid for trains of gears: 3I with  $i_N \geq 100$ , ICI with  $i_N \geq 100$ , 4I with  $i_N \geq 315$ , C3I with  $i_N = 400$ .

2) Values valid for trains of gears: 3I with  $i_N = 80$ , ICI with  $i_N \geq 80$ .

3) Values valid for train of gears: ICI with  $i_N \geq 63$ .

### Netzfrequenz 60 Hz

Wenn der Motor mit einer Frequenz von 60 Hz (Kap. 2 b) versorgt wird, so ändern sich die Eigenschaften des Getriebemotors wie folgt.

- Die Drehzahl  $n_2$  steigt um 20%.
- Die Leistung  $P_1$  kann konstant bleiben oder steigen (Kap. 2 b).
- Das Drehmoment  $M_2$  und der Betriebsfaktor  $f_s$  ändern sich wie folgt:

$$M_{2 \text{ 60 Hz}} = M_{2 \text{ 50 Hz}} \cdot \frac{P_{1 \text{ 60 Hz}}}{1,2 \cdot P_{1 \text{ 50 Hz}}};$$

### Operation on 60 Hz supply

When motor is fed with 60 Hz frequency (ch. 2 b), the gearmotor specifications vary as follows.

- Speed  $n_2$  increases by 20%.
- Power  $P_1$  may either remain constant or increase (ch. 2 b).
- Torque  $M_2$  and service factor  $f_s$  vary as follows:

$$f_{s \text{ 60 Hz}} = f_{s \text{ 50 Hz}} \cdot \frac{1,12 \cdot P_{1 \text{ 50 Hz}}}{P_{1 \text{ 60 Hz}}}$$

### Kombieinheiten Getriebe und Getriebemotoren

Für hohe Übersetzungen und niedrige Abtriebsdrehzahlen lassen sich **normale einzelne** Getriebe und/oder Getriebemotoren paaren (Stirnrad- und Kegelstirnradtypen + Getriebe oder Getriebemotoren mit koaxialer Wellenannordnung) (s. Kap. 17); bei Bedarf bitte rückfragen.

### Combined gear reducer and gearmotor units

In order to obtain high transmission ratios and low output speeds it is possible to combine **normal single** gear reducers and/or gearmotors (parallel or right angle shafts + coaxial gear reducers or gearmotors) (see ch. 17); consult us if need be.



**7 - Nennleistungen und Nenndrehmomente (Stirradgetriebe)**  
**7 - Nominal powers and torques (parallel shafts)**

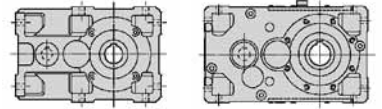

			Getriebegröße - Gear reducer size																
$n_{N2}$	$n_1$	$i_N$	$P_{N2}$ kW $M_{N2}$ daN m ... / i																
			50	63	64	80	81	100	125	140	160	180	200	225	250	280	320	321	360
min <sup>-1</sup>																			
560	1 400	2,5	—	15,4 26,5 1/2,53	—	33,6 56 1/2,44	—	64 112 1/2,55	130 224 1/2,53	—	300 500 1/2,44	—	591 1 030 1/2,55	—	1 190 2 060 1/2,53	—	2 130 3 550 1/2,44 ▲	2 700 4 500 1/2,44 ▲	—
450	1 400	3,15	—	11,8 26,5 1/3,28	—	26,2 56 1/3,13	—	50 112 1/3,27	100 224 1/3,28	157 335 1/3,13	234 500 1/3,13	320 710 1/3,25	462 1 030 1/3,27	646 1 400 1/3,18	919 2 060 1/3,28	1 290 2 800 1/3,19	1 660 3 550 1/3,13	2 110 4 500 1/3,13	2 530 5 600 1/3,25 ▲
	1 120	2,5	—	12,5 27 1/2,53	—	27,4 57 1/2,44	—	53 115 1/2,55	107 230 1/2,53	—	247 514 1/2,44	—	485 1 060 1/2,55	—	981 2 120 1/2,53	—	1 750 3 650 1/2,44	2 220 4 620 1/2,44	—
355	1 400	4	—	9,7 26,5 1/4	—	19,7 56 1/4,16	—	41,9 112 1/3,92	82 224 1/4	117 325 1/4,08	173 487 1/4,13	244 690 1/4,15	355 1 000 1/4,13	490 1 360 1/4,07	733 2 000 1/4	978 2 720 1/4,08	1 240 3 450 1/4,07	1 530 4 250 1/4,07	2 000 5 450 1/4
	1 120	3,15	—	9,7 27 1/3,28	—	21,4 57 1/3,13	—	41,3 115 1/3,27	82 230 1/3,28	129 345 1/3,13	192 514 1/3,13	264 731 1/3,25	380 1 060 1/3,27	533 1 440 1/3,18	755 2 120 1/3,28	1 060 2 880 1/3,19	1 370 3 650 1/3,13	1 730 4 620 1/3,13	2 080 5 760 1/3,25
	900	2,5	—	10,3 27,6 1/2,53	—	22,5 58 1/2,44	—	43,5 118 1/2,55	88 236 1/2,53	—	204 528 1/2,44	—	400 1 080 1/2,55	—	808 2 170 1/2,53	—	1 450 3 760 1/2,44	1 830 4 740 1/2,44	—
280	1 400	5	—	6,7 23 1/5	—	13,7 48,7 1/5,2	—	29,7 98 1/4,82	57 195 1/5	82 280 1/4,92	127 425 1/5,07	173 600 1/4,13	261 875 1/4,92	341 1 180 1/5,07	505 1 750 1/5,08	692 2 360 1/5	893 3 000 1/4,92	1 060 3 550 1/4,92	1 370 4 750 1/5,07
	1 120	4	—	7,9 27 1/4	—	16,1 57 1/4,16	—	34,4 115 1/3,92	67 230 1/4	96 334 1/4,08	142 501 1/4,13	200 710 1/4,15	291 1 030 1/4,13	404 1 400 1/4,07	602 2 050 1/4	805 2 800 1/4,08	1 020 3 550 1/4,07	1 260 4 360 1/4,07	1 640 5 610 1/4
	900	3,15	—	7,9 27,6 1/3,28	—	17,6 58 1/3,13	—	34,1 118 1/3,27	68 236 1/3,28	107 354 1/3,13	159 528 1/3,13	218 751 1/3,25	313 1 080 1/3,27	441 1 490 1/3,18	622 2 170 1/3,28	876 2 960 1/3,19	1 130 3 760 1/3,13	1 430 4 740 1/3,13	1 720 5 920 1/3,25
	710	2,5	—	8,3 28,2 1/2,53	—	18,1 60 1/2,44	—	35,3 121 1/2,55	71 243 1/2,53	—	165 543 1/2,44	—	324 1 110 1/2,55	—	655 2 230 1/2,53	—	1 180 3 860 1/2,44	1 480 4 860 1/2,44	—
224	1 400	6,3	3,33 14,6 21/6,42	6,1 27,4 21/6,53	7 32,7 21/6,86	13,1 57 21/6,41	14,9 65 21/6,41	27,2 119 21/6,42	54 239 21/6,53	—	109 478 21/6,41	—	251 1 100 21/6,42	—	493 2 200 21/6,53	—	852 3 730 21/6,41	1 010 4 400 21/6,41	—
	1 120	5	—	5,5 23,5 1/5	—	11,2 49,7 1/5,2	—	24,4 100 1/4,82	47 200 1/5	68 288 1/5	143 436 1/4,92	143 616 1/5,07	214 898 1/4,92	281 1 220 1/5,07	415 1 800 1/5,08	570 2 430 1/5	734 3 080 1/4,92	870 3 650 1/4,92	1 130 4 890 1/5,07
	900	4	—	6,5 27,6 1/4	—	13,2 58 1/4,16	—	28,4 118 1/3,92	56 236 1/4	79 344 1/4,08	117 515 1/4,13	166 730 1/4,15	240 1 050 1/4,13	334 1 440 1/4,07	497 2 110 1/4	665 2 880 1/4,08	845 3 650 1/4,07	1 040 4 480 1/4,07	1 360 5 760 1/4
	710	3,15	—	6,4 28,2 1/3,28	—	14,2 60 1/3,13	—	27,6 121 1/3,27	55 243 1/3,28	87 365 1/3,13	129 543 1/3,13	177 773 1/3,25	253 1 110 1/3,27	359 1 530 1/3,18	504 2 230 1/3,28	711 3 050 1/3,19	917 3 860 1/3,13	1 150 4 860 1/3,13	1 400 6 100 1/3,25
	560	2,5	—	6,7 28,7 1/2,53	—	14,6 61 1/2,44	—	28,6 125 1/2,55	58 249 1/2,53	—	134 558 1/2,44	—	262 1 140 1/2,55	—	530 2 290 1/2,53	—	953 3 970 1/2,44	1 200 4 990 1/2,44	—
180	1 400	8	3,03 16,6 21/8,01	5,5 30,9 21/8,26	7 38,3 21/7,99	11,9 65 21/8,03	14,2 78 21/8,03	24,4 133 21/8,01	47,4 267 21/8,26	—	109 599 21/8,03	—	224 1 220 21/8,01	—	436 2 460 21/8,26	—	783 4 290 21/8,03	976 5 350 21/8,03	—
	1 120	6,3	2,68 14,7 21/6,42	4,94 27,5 21/6,53	5,6 32,9 21/6,86	10,6 58 21/6,41	12 66 21/6,41	22,1 121 21/6,42	43,4 242 21/6,53	—	89 485 21/6,41	—	203 1 110 21/6,42	—	399 2 230 21/6,53	—	694 3 800 21/6,41	815 4 460 21/6,41	—
	900	5	—	4,51 23,9 1/5	—	9,2 51 1/5,2	—	20,1 103 1/4,82	38,7 205 1/5	56 296 1/5	86 448 1/4,92	118 632 1/5,07	176 921 1/4,92	232 1 250 1/5,07	342 1 840 1/5,08	471 2 500 1/5	605 3 160 1/4,92	719 3 760 1/4,92	933 5 020 1/5,07
	710	4	—	5,2 28,2 1/4	—	10,6 60 1/4,16	—	23 121 1/3,92	45,1 243 1/4	65 354 1/4,08	95 529 1/4,13	134 751 1/4,15	195 1 080 1/4,13	272 1 490 1/4,07	402 2 170 1/4	540 2 960 1/4,08	686 3 760 1/4,07	841 4 600 1/4,07	1 100 5 930 1/4
	560	3,15	—	5,1 28,7 1/3,28	—	11,4 61 1/3,13	—	22,3 125 1/3,27	44,4 249 1/3,28	70 375 1/3,13	104 558 1/3,13	143 795 1/3,25	205 1 140 1/3,27	291 1 580 1/3,18	408 2 290 1/3,28	577 3 140 1/3,19	744 3 970 1/3,13	934 4 990 1/3,13	1 130 6 270 1/3,25
160	1 400	9	—	—	—	—	—	—	—	55 346 21/9,22	95 601 21/9,24	109 694 21/9,31	203 1 220 21/8,85	257 1 560 21/8,88	392 2 460 21/9,19	506 3 180 21/9,22	681 4 290 21/9,24	848 5 350 21/9,24	1 010 6 390 21/9,31
	1 250	8	2,72 16,6 21/8,01	4,9 30,9 21/8,26	6,3 38,5 21/7,99	10,7 66 21/8,03	12,7 78 21/8,03	21,9 134 21/8,01	42,6 269 21/8,26	—	98 603 21/8,03	—	201 1 230 21/8,01	—	391 2 470 21/8,26	—	704 4 320 21/8,03	877 5 380 21/8,03	—
	1 000	6,3	2,4 14,7 21/6,42	4,43 27,6 21/6,53	5 33 21/6,86	9,4 58 21/6,41	10,8 66 21/6,41	19,8 121 21/6,42	39 243 21/6,53	—	80 488 21/6,41	—	182 1 120 21/6,42	—	359 2 240 21/6,53	—	626 3 830 21/6,41	732 4 490 21/6,41	—

Bei  $n_1$  größer als 1 400 min<sup>-1</sup> oder kleiner als 560 min<sup>-1</sup> s. Kap. 6 und Tabelle auf Seite 35.  
 ▲ Eventuelle Zwangsschmierung mit Wärmeaustauscher: Bitte rückfragen.

For  $n_1$  higher than 1 400 min<sup>-1</sup> or lower than 560 min<sup>-1</sup>, see ch. 6 and table on page 35.  
 ▲ Possible forced lubrication with heat exchanger: consult us.

7 - Nennleistungen und Nenndrehmomente (Stirradgetriebe)  
 7 - Nominal powers and torques (parallel shafts)

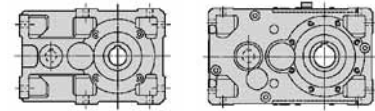

$n_{N2}$   $n_1$   $i_N$ min <sup>-1</sup>			Getriebegröße - Gear reducer size																
			$P_{N2}$ kW $M_{N2}$ daN m ... / i																
			50	63	64	80	81	100	125	140	160	180	200	225	250	280	320	321	360
160	800	5	—	4,05 24,1 1/5	—	8,3 51 1/5,2	—	18,1 104 1/4,82	34,9 208 1/5	50 300 1/5	77 454 1/4,92	106 641 1/5,07	159 934 1/4,92	209 1270 1/5,07	308 1870 1/5,08	425 2540 1/5	545 3210 1/4,92	648 3810 1/4,92	841 5090 1/5,07
	630	4	—	4,69 28,4 1/4	—	9,5 60 1/4,16	—	20,7 123 1/3,92	40,5 246 1/4	58 359 1/4,08	86 537 1/4,13	121 762 1/4,15	175 1100 1/4,13	245 1510 1/4,07	362 2200 1/4	486 3000 1/4,08	618 3810 1/4,07	756 4660 1/4,07	992 6010 1/4
140	1400	10	2,37 16,6 21/10,2	4,22 30,9 21/10,7	5,1 38,9 21/11,2	9,3 65 21/10,3	11,1 78 21/10,3	19,1 133 21/10,2	36,5 267 21/10,7	55 383 21/10,2	86 601 21/10,3	109 796 21/10,7	175 1220 21/10,2	252 1710 21/9,95	335 2460 21/10,7	476 3380 21/10,4	611 4290 21/10,3	762 5350 21/10,3	929 6760 21/10,7
	1250	9	—	—	—	—	—	—	49,4 348 21/9,22	86 604 21/9,24	98 699 21/9,31	182 1230 21/8,85	231 1570 21/8,88	352 2470 21/9,19	454 3200 21/9,22	612 4320 21/9,24	762 5380 21/9,24	904 6430 21/9,31	
	1120	8	2,44 16,7 21/8,01	4,4 31 21/8,26	5,7 38,6 21/7,99	9,6 66 21/8,03	11,5 78 21/8,03	19,8 135 21/8,01	38,4 271 21/8,26	—	89 607 21/8,03	—	181 1240 21/8,01	—	353 2490 21/8,26	—	634 4340 21/8,03	790 5410 21/8,03	—
	900	6,3	2,17 14,8 21/6,42	3,99 27,7 21/6,53	4,55 33,1 21/6,86	8,5 58 21/6,41	9,7 66 21/6,41	17,9 122 21/6,42	35,3 245 21/6,53	—	72 491 21/6,41	—	165 1120 21/6,42	—	325 2250 21/6,53	—	568 3870 21/6,41	663 4510 21/6,41	—
	710	5	—	3,63 24,4 1/5	—	7,4 52 1/5,2	—	16,3 106 1/4,82	31,4 211 1/5	45,3 305 1/5	69 460 1/4,92	95 650 1/5,07	143 946 1/4,92	189 1290 1/5,07	277 1890 1/5,08	382 2570 1/5	491 3250 1/4,92	584 3860 1/4,92	757 5160 1/5,07
	560	4	—	4,21 28,7 1/4	—	8,6 61 1/4,16	—	18,6 125 1/3,92	36,5 249 1/4	52 364 1/4,08	77 544 1/4,13	109 773 1/4,15	158 1110 1/4,13	221 1530 1/4,07	326 2220 1/4	438 3050 1/4,08	557 3860 1/4,07	680 4720 1/4,07	894 6100 1/4
125	1400	11,2	—	—	—	—	—	—	49,8 404 21/11,9	74 601 21/11,9	106 858 21/11,8	160 1220 21/11,2	218 1710 21/11,5	305 2460 21/11,8	416 3380 21/11,9	547 4290 21/11,5	682 5350 21/11,5	838 6760 21/11,8	
	1250	10	2,12 16,6 21/10,2	3,77 30,9 21/10,7	4,57 39,1 21/11,2	8,3 66 21/10,3	9,9 78 21/10,3	17,2 134 21/10,2	32,8 269 21/10,7	49,4 385 21/10,2	77 604 21/10,3	98 802 21/10,7	157 1230 21/10,2	227 1720 21/9,95	301 2470 21/10,7	428 3400 21/10,4	549 4320 21/10,3	684 5380 21/10,3	834 6810 21/10,7
	1120	9	—	—	—	—	—	—	44,6 350 21/9,22	77 608 21/9,24	89 703 21/9,31	164 1240 21/8,85	208 1580 21/8,88	317 2490 21/9,19	410 3220 21/9,22	551 4340 21/9,24	687 5410 21/9,24	815 6470 21/9,31	
	1000	8	2,19 16,7 21/8,01	3,94 31,1 21/8,26	5,1 38,7 21/7,99	8,6 66 21/8,03	10,3 79 21/8,03	17,8 136 21/8,01	34,5 272 21/8,26	—	80 611 21/8,03	—	163 1240 21/8,01	—	317 2500 21/8,26	—	570 4370 21/8,03	710 5450 21/8,03	—
	800	6,3	1,94 14,8 21/6,42	3,56 27,8 21/6,53	4,05 33,2 21/6,86	7,6 58 21/6,41	8,7 66 21/6,41	16 123 21/6,42	31,6 246 21/6,53	—	65 494 21/6,41	—	147 1130 21/6,42	—	290 2260 21/6,53	—	510 3900 21/6,41	593 4540 21/6,41	—
	630	5	—	3,25 24,6 1/5	—	6,6 52 1/5,2	—	14,7 107 1/4,82	28,2 214 1/5	40,8 309 1/5	62 466 1/4,92	86 658 1/5,07	128 959 1/4,92	170 1310 1/5,07	249 1920 1/5,08	344 2610 1/5	441 3290 1/4,92	525 3920 1/4,92	681 5240 1/5,07
112	1400	12,5	1,91 16,1 21/12,3	3,46 30,9 21/13,1	4,07 37,8 21/13,6	7 65 21/13,7	8,1 76 21/13,7	15,9 133 21/12,3	30 267 21/13,1	43,2 392 21/13,3	63 586 21/13,6	89 833 21/13,6	135 1190 21/13	191 1660 21/12,8	268 2390 21/13,1	362 3290 21/13,3	456 4160 21/13,4	556 5070 21/13,4	734 6590 21/13,1
	1250	11,2	—	—	—	—	—	—	44,7 407 21/11,9	67 604 21/11,9	96 864 21/11,8	144 1230 21/11,2	196 1720 21/11,5	274 2470 21/11,8	374 3400 21/11,9	491 4320 21/11,5	612 5380 21/11,5	753 6810 21/11,8	
	1120	10	1,91 16,7 21/10,2	3,39 31 21/10,7	4,11 39,2 21/11,2	7,5 66 21/10,3	8,9 78 21/10,3	15,5 135 21/10,2	29,6 271 21/10,7	44,6 388 21/10,2	69 608 21/10,3	89 807 21/10,7	142 1240 21/10,2	204 1730 21/9,95	272 2490 21/10,7	386 3420 21/10,4	495 4340 21/10,3	617 5410 21/10,3	752 6850 21/10,7
	1000	9	—	—	—	—	—	—	40 353 21/9,22	69 612 21/9,24	80 708 21/9,31	147 1240 21/8,85	187 1590 21/8,88	285 2500 21/9,19	368 3240 21/9,22	495 4370 21/9,24	617 5450 21/9,24	732 6510 21/9,31	
	900	8	1,97 16,8 21/8,01	3,56 31,2 21/8,26	4,58 38,8 21/7,99	7,8 66 21/8,03	9,3 79 21/8,03	16,1 137 21/8,01	31,2 274 21/8,26	—	72 614 21/8,03	—	147 1250 21/8,01	—	287 2510 21/8,26	—	516 4400 21/8,03	643 5480 21/8,03	—
	710	6,3	1,73 14,9 21/6,42	3,17 27,9 21/6,53	3,61 33,3 21/6,86	6,8 58 21/6,41	7,7 67 21/6,41	14,3 124 21/6,42	28,2 248 21/6,53	—	58 497 21/6,41	—	132 1140 21/6,42	—	259 2280 21/6,53	—	457 3940 21/6,41	530 4570 21/6,41	—
560	5	—	2,92 24,9 1/5	—	6 53 1/5,2	—	13,2 108 1/4,82	25,4 216 1/5	36,8 314 1/5	56 472 1/4,92	77 667 1/5,07	116 971 1/4,92	153 1320 1/5,07	224 1940 1/5,08	310 2650 1/5	397 3340 1/4,92	473 3970 1/4,92	614 5310 1/5,07	
100	1400	14	—	—	—	—	—	—	39,1 392 21/14,7	63 601 21/14,1	88 868 21/14,4	132 1250 21/13,9	157 1560 21/14,6	227 2260 21/14,6	309 3100 21/14,7	451 4400 21/14,3	552 5380 21/14,3	696 6840 21/14,4	
	1250	12,5	1,72 16,1 21/12,3	3,1 30,9 21/13,1	3,64 37,9 21/13,6	6,3 66 21/13,7	7,3 76 21/13,7	14,3 134 21/12,3	26,9 269 21/13,1	38,8 395 21/13,3	57 589 21/13,6	80 839 21/13,6	121 1200 21/13,2	172 1670 21/12,8	241 2400 21/13,1	325 3310 21/13,4	410 4190 21/13,4	500 5100 21/13,4	660 6630 21/13,1

Bei  $n_1$  größer als 1 400 min<sup>-1</sup> oder kleiner als 560 min<sup>-1</sup> s. Kap. 6 und Tabelle auf Seite 35.

For  $n_1$  higher than 1 400 min<sup>-1</sup> or lower than 560 min<sup>-1</sup>, see ch. 6 and table on page 35.









7 - Nennleistungen und Nenndrehmomente (Stirradgetriebe)  
7 - Nominal powers and torques (parallel shafts)

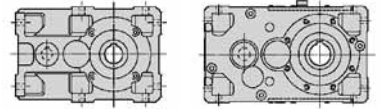

			Getriebegröße - Gear reducer size																	
			50	63	64	80	81	100	125	140	160	180	200	225	250	280	320	321	360	
$n_{N2}$	$n_1$	$i_N$	$P_{N2}$ kW $M_{N2}$ daN m ... / i																	
$\text{min}^{-1}$																				
31,5	560	18	—	—	—	—	—	—	—	14,2 425 21/17,6	20,4 630 21/18,1	26,3 809 21/18	42,7 1 280 21/17,6	58 1 800 21/17,8	85 2 570 21/17,8	116 3 550 21/17,9	149 4 500 21/17,8	185 5 600 21/17,8	228 7 100 21/18,3	
28	1 400	50	—	0,93 31,5 31/49,4	1,14 40 31/51,5	1,97 67 31/49,8	2,35 80 31/49,8	4,01 140 31/51,2	8,3 280 31/49,5	12 412 31/50,4	17,8 615 31/50,8	25,1 875 31/51	34,9 1 250 31/52,6	49,5 1 750 31/51,8	71 2 500 31/51,7	96 3 450 31/52,7	121 4 370 31/52,9	147 5 300 31/52,9	195 6 900 31/52	
	1 250	45	—	—	—	—	—	—	—	12,3 425 31/45,1	18,6 630 31/44,4	26,6 900 31/44,2	36,9 1 280 31/45,4	51 1 800 31/46,6	72 2 570 31/46,7	99 3 550 31/47,1	129 4 500 31/45,5	161 5 600 31/45,5	199 7 100 31/46,8	
	1 120	40	—	0,91 31,5 31/40,8	1,07 38,7 31/42,5	1,8 67 31/43,6	2,09 78 31/43,6	4,2 140 31/39,1	8 280 31/40,8	12,5 414 31/38,7	19,2 630 31/38,5	25,2 859 31/39,9	36,1 1 280 31/41,5	52 1 800 31/40,4	71 2 570 31/42,4	101 3 550 31/41,2	130 4 500 31/40,7	161 5 600 31/40,7	197 7 100 31/42,3	
	1 000	35,5	—	—	—	—	—	—	—	—	11,9 425 31/37,5	18,1 630 31/36,5	25,9 900 31/36,3	38,9 1 280 31/34,4	53 1 800 31/35,4	73 2 570 31/36,9	100 3 550 31/37,2	126 4 500 31/37,4	157 5 600 31/37,4	193 7 100 31/38,4
	900	31,5	—	0,84 30 31/33,5	0,9 33,5 31/34,9	1,93 67 31/32,8	2,16 75 31/32,8	3,7 128 31/32,6	7,4 265 31/33,5	12,2 418 31/32,2	18,8 630 31/31,6	25 869 31/32,8	38,3 1 280 31/31,5	55 1 800 31/30,6	72 2 570 31/33,5	103 3 550 31/32,5	127 4 500 31/33,5	158 5 600 31/33,5	193 7 100 31/34,7	
	800	28	—	—	—	—	—	—	3,17 109 21/28,8	11 380 31/29,1	18,6 630 31/28,4	22,3 762 31/28,6	39,4 1 280 31/27,2	53 1 710 31/27,3	75 2 570 31/28,7	100 3 440 31/28,8	126 4 500 31/30	156 5 600 31/30	194 7 020 31/30,3	
	710	25	—	0,39 12,8 21/24,4	0,84 27,2 21/24,1	0,99 33,5 21/25,1	1,66 58 21/26	1,92 67 21/26	3,82 122 21/23,7	7,5 243 21/24,1	11 355 21/24,1	16 530 21/24,6	22 750 21/25,4	33,4 1 090 21/24,2	44,7 1 500 21/25	65 2 180 21/25	91 3 000 21/24,6	112 3 750 21/25	134 4 500 21/25	173 6 000 21/25,7
	630	22,4	—	—	—	—	—	—	—	—	11,8 387 21/21,7	17 580 21/22,5	23,3 825 21/23,3	35,1 1 180 21/22,2	47,4 1 650 21/23	71 2 360 21/22	97 3 250 21/22,2	119 4 120 21/22,8	141 4 870 21/22,8	184 6 500 21/23,4
	560	20	—	0,424 14,5 21/20,1	0,96 31,5 21/19,3	1,13 38,7 21/20,1	1,89 67 21/20,8	2,18 78 21/20,8	4,25 140 21/19,3	8,5 280 21/19,6	12,3 412 21/19,6	17,4 615 21/20,7	24,7 875 21/20,8	36 1 250 21/20,3	51 1 750 21/20	74 2 500 21/19,7	101 3 450 21/20,1	124 4 370 21/20,6	151 5 300 21/20,6	199 6 900 21/20,3
25	1 400	56	—	—	—	—	—	—	—	11 415 31/55,4	16,6 630 31/55,5	22,9 864 31/55,3	34,7 1 280 31/54,1	47,5 1 800 31/55,5	68 2 570 31/55,6	93 3 550 31/56	114 4 500 31/57,8	142 5 600 31/57,8	175 7 100 31/59,4	
	1 250	50	—	0,83 31,5 31/49,4	1,02 40 31/51,5	1,76 67 31/49,8	2,1 80 31/49,8	3,58 140 31/51,2	7,4 280 31/49,5	10,7 412 31/50,4	15,9 615 31/50,8	22,4 875 31/51	31,1 1 250 31/52,6	44,2 1 750 31/51,8	63 2 500 31/51,7	86 3 450 31/52,7	108 4 370 31/52,9	131 5 300 31/52,9	174 6 900 31/52	
	1 120	45	—	—	—	—	—	—	—	11,1 425 31/45,1	16,6 630 31/44,4	23,9 900 31/44,2	33 1 280 31/45,4	45,3 1 800 31/46,6	65 2 570 31/46,7	88 3 550 31/47,1	116 4 500 31/45,5	144 5 600 31/45,5	178 7 100 31/46,8	
	1 000	40	—	0,81 31,5 31/40,8	0,95 38,7 31/42,5	1,61 67 31/43,6	1,86 78 31/43,6	3,75 140 31/39,1	7,2 280 31/40,8	11,3 416 31/38,7	17,1 630 31/38,5	22,7 864 31/39,9	32,3 1 280 31/41,5	46,7 1 800 31/40,4	63 2 570 31/42,4	90 3 550 31/41,2	116 4 500 31/40,7	144 5 600 31/40,7	176 7 100 31/42,3	
	900	35,5	—	—	—	—	—	—	—	—	10,7 425 31/37,5	16,3 630 31/36,5	23,3 900 31/36,3	35 1 280 31/34,4	48 1 800 31/35,4	66 2 570 31/36,9	90 3 550 31/37,2	113 4 500 31/37,4	141 5 600 31/37,4	174 7 100 31/38,4
	800	31,5	—	0,75 30 31/33,5	0,8 33,5 31/34,9	1,71 67 31/32,8	1,92 75 31/32,8	3,29 128 31/32,6	6,6 265 31/33,5	11 421 31/32,2	16,7 630 31/31,6	22,3 875 31/32,8	34 1 280 31/31,5	49,2 1 800 31/30,6	64 2 570 31/33,5	91 3 550 31/32,5	113 4 500 31/33,5	140 5 600 31/33,5	171 7 100 31/34,7	
	710	28	—	—	—	—	—	—	2,81 109 21/28,8	9,8 383 31/29,1	16,5 630 31/28,4	20 767 31/28,6	35 1 280 31/27,2	47 1 730 31/27,3	67 2 570 31/28,7	89 3 470 31/28,8	111 4 500 31/30	139 5 600 31/30	174 7 070 31/30,3	
	630	25	—	0,346 12,8 21/24,4	0,74 27,2 21/24,1	0,88 33,5 21/25,1	1,47 58 21/26	1,7 67 21/26	3,39 122 21/23,7	6,7 243 21/24,1	9,7 355 21/24,1	14,2 530 21/24,6	19,5 750 21/25,4	29,7 1 090 21/24,2	39,6 1 500 21/25	58 2 180 21/25	80 3 000 21/24,6	99 3 750 21/25	119 4 500 21/25	154 6 000 21/25,7
	560	22,4	—	—	—	—	—	—	—	—	10,5 387 21/21,7	15,1 580 21/22,5	20,7 825 21/23,3	31,2 1 180 21/22,2	42,1 1 650 21/23	63 2 360 21/22	86 3 250 21/22,2	106 4 120 21/22,8	125 4 870 21/22,8	163 6 500 21/23,4
22,4	1 400	63	—	0,77 31,5 31/60,1	0,91 38,7 31/62,6	1,48 67 31/66,3	1,71 78 31/66,3	3,34 140 31/61,5	6,8 280 31/60,2	9,7 412 31/62	14,2 615 31/63,5	20,1 875 31/63,8	29,3 1 250 31/62,6	41,6 1 750 31/61,7	60 2 500 31/61,5	81 3 450 31/62,7	95 4 370 31/67,1	116 5 300 31/67,1	153 6 900 31/66	
	1 250	56	—	—	—	—	—	—	—	9,9 418 31/55,4	14,9 630 31/55,5	20,6 869 31/55,3	31 1 280 31/54,1	42,4 1 800 31/55,5	60 2 570 31/56	83 3 550 31/57,8	102 4 500 31/57,8	127 5 600 31/57,8	156 7 100 31/59,4	
	1 120	50	—	0,75 31,5 31/49,4	0,91 40 31/51,5	1,58 67 31/49,8	1,88 80 31/49,8	3,21 140 31/51,2	6,6 280 31/49,5	9,6 412 31/50,4	14,2 615 31/50,8	20,1 875 31/51	27,9 1 250 31/52,6	39,6 1 750 31/51,8	57 2 500 31/51,7	77 3 450 31/52,7	97 4 370 31/52,9	118 5 300 31/52,9	156 6 900 31/52	
	1 000	45	—	—	—	—	—	—	—	—	9,9 425 31/45,1	14,9 630 31/44,4	21,3 900 31/44,2	29,5 1 280 31/45,4	40,4 1 800 31/46,6	58 2 570 31/47,1	79 3 550 31/47,1	104 4 500 31/45,5	129 5 600 31/45,5	159 7 100 31/46,8

Bei  $n_1$  größer als 1 400 min<sup>-1</sup> oder kleiner als 560 min<sup>-1</sup> s. Kap. 6 und Tabelle auf Seite 35.

For  $n_1$  higher than 1 400 min<sup>-1</sup> or lower than 560 min<sup>-1</sup>, see ch. 6 and table on page 35.

7 - Nennleistungen und Nenndrehmomente (Stirnradgetriebe)  
 7 - Nominal powers and torques (parallel shafts)

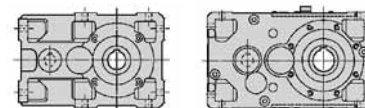

			Getriebegröße - Gear reducer size																
$n_{N2}$	$n_1$	$i_N$	$P_{N2}$ kW $M_{N2}$ daNm ... // $i$																
			50	63	64	80	81	100	125	140	160	180	200	225	250	280	320	321	360
22,4	900	40	—	0,73 31,5 31/40,8	0,86 38,7 31/42,5	1,45 67 31/43,6	1,68 78 31/43,6	3,37 140 31/39,1	6,5 280 31/40,8	10,2 418 31/38,7	15,4 630 31/38,5	20,5 869 31/39,9	29 1 280 31/41,5	42 1 800 31/40,4	57 2 570 31/42,4	81 3 550 31/41,2	104 4 500 31/40,7	130 5 600 31/40,7	158 7 100 31/42,3
	800	35,5	—	—	—	—	—	—	—	9,5 425 31/37,5	14,5 630 31/36,5	20,8 900 31/36,3	31,1 1 280 31/34,4	42,7 1 800 31/35,4	58 2 570 31/36,9	80 3 550 31/37,2	101 4 500 31/37,4	126 5 600 31/37,4	155 7 100 31/38,4
	710	31,5	—	0,67 30 31/33,5	0,71 33,5 31/34,9	1,52 67 31/32,8	1,7 75 31/32,8	2,92 128 31/32,6	5,9 265 31/33,5	9,8 424 31/32,2	14,8 630 31/31,6	20 880 31/32,8	30,2 1 280 31/31,5	43,7 1 800 31/30,6	57 2 570 31/33,5	81 3 550 31/32,5	100 4 500 31/33,5	124 5 600 31/33,5	152 7 100 31/34,7
	630	28	—	—	—	—	—	2,49 109 21/28,8	—	8,7 385 31/29,1	14,6 630 31/28,4	17,8 772 31/28,6	31 1 280 31/27,2	42 1 740 31/27,3	59 2 570 31/28,7	80 3 490 31/28,8	99 4 500 31/30	123 5 600 31/30	155 7 100 31/30,3
	560	25	—	0,308 12,8 21/24,4	0,66 27,2 21/24,1	0,78 33,5 21/25,1	1,31 58 21/26	1,51 67 21/26	3,02 122 21/23,7	5,9 243 21/24,1	8,6 355 21/24,1	12,6 530 21/24,6	17,3 750 21/25,4	26,4 1 090 21/24,2	35,2 1 500 21/25	51 2 180 21/25	71 3 000 21/24,6	88 3 750 21/25	106 4 500 21/25,7
20	1 400	71	—	—	—	—	—	—	—	8,6 425 31/72,8	12,3 630 31/74,9	17,7 900 31/74,6	25,9 1 280 31/72,6	35,4 1 800 31/74,5	50 2 570 31/74,7	69 3 550 31/75,3	93 4 500 31/71	116 5 600 31/71	143 7 100 31/73
	1 250	63	—	0,69 31,5 31/60,1	0,81 38,7 31/62,6	1,32 67 31/66,3	1,53 78 31/66,3	2,98 140 31/61,5	6,1 280 31/60,2	8,7 412 31/62	12,7 615 31/63,5	18 875 31/63,8	26,1 1 250 31/62,6	37,1 1 750 31/61,7	53 2 500 31/61,5	72 3 450 31/62,7	85 4 370 31/67,1	103 5 300 31/67,1	137 6 900 31/66
	1 120	56	—	—	—	—	—	—	—	8,9 420 31/55,4	13,3 630 31/55,5	18,5 874 31/55,3	27,7 1 280 31/54,1	38 1 800 31/55,5	54 2 570 31/55,6	74 3 550 31/56	91 4 500 31/57,8	114 5 600 31/57,8	140 7 100 31/59,4
	1 000	50	—	0,67 31,5 31/49,4	0,81 40 31/51,5	1,41 67 31/49,8	1,68 80 31/49,8	2,86 140 31/51,2	5,9 280 31/49,5	8,6 412 31/50,4	12,7 615 31/50,8	18 875 31/51	24,9 1 250 31/52,6	35,4 1 750 31/51,8	51 2 500 31/51,7	69 3 450 31/52,7	87 4 370 31/52,9	105 5 300 31/52,9	139 6 900 31/52
	900	45	—	—	—	—	—	—	—	8,9 425 31/45,1	13,4 630 31/44,4	19,2 900 31/44,2	26,6 1 280 31/45,4	36,4 1 800 31/46,6	52 2 570 31/46,7	71 3 550 31/47,1	93 4 500 31/45,5	116 5 600 31/45,5	143 7 100 31/46,8
	800	40	—	0,65 31,5 31/40,8	0,76 38,7 31/42,5	1,29 67 31/43,6	1,49 78 31/43,6	3 140 31/39,1	5,7 280 31/40,8	9,1 421 31/38,7	13,7 630 31/38,5	18,3 875 31/39,9	25,8 1 280 31/41,5	37,3 1 800 31/40,4	51 2 570 31/42,4	72 3 550 31/41,2	93 4 500 31/40,7	115 5 600 31/40,7	141 7 100 31/42,3
	710	35,5	—	—	—	—	—	—	—	8,4 425 31/37,5	12,8 630 31/36,5	18,4 900 31/36,3	27,6 1 280 31/34,4	37,9 1 800 31/35,4	52 2 570 31/36,9	71 3 550 31/37,2	90 4 500 31/37,4	111 5 600 31/37,4	137 7 100 31/38,4
	560	28	—	0,59 30 31/33,5	0,63 33,5 31/34,9	1,35 67 31/32,8	1,51 75 31/32,8	2,59 128 31/32,6	5,2 265 31/33,5	8,7 425 31/32,2	13,1 630 31/31,6	17,8 886 31/32,8	26,8 1 280 31/31,5	38,8 1 800 31/30,6	51 2 570 31/33,5	72 3 550 31/32,5	89 4 500 31/33,5	110 5 600 31/33,5	135 7 100 31/34,7
18	1 400	80	—	0,53 27,2 31/75,2	0,63 33,5 31/78,2	1,03 58 31/82,7	1,19 67 31/82,7	2,37 122 31/75,5	4,73 243 31/75,3	7,4 412 31/81,4	10,5 615 31/85,7	14,9 875 31/86,1	21,8 1 250 31/84	31 1 750 31/82,7	44,3 2 500 31/82,7	60 3 450 31/84,3	78 4 370 31/82,5	94 5 300 31/82,5	125 6 900 31/81,1
	1 250	71	—	—	—	—	—	—	—	7,6 425 31/72,8	11 630 31/74,9	15,8 900 31/74,6	23,1 1 280 31/72,6	31,6 1 800 31/74,5	45 2 570 31/74,7	62 3 550 31/75,3	83 4 500 31/71	103 5 600 31/71	127 7 100 31/73
	1 120	63	—	0,61 31,5 31/60,1	0,72 38,7 31/62,6	1,19 67 31/66,3	1,37 78 31/66,3	2,67 140 31/61,5	5,5 280 31/60,2	7,8 412 31/62	11,4 615 31/63,5	16,1 875 31/63,8	23,4 1 250 31/62,6	33,3 1 750 31/61,7	47,6 2 500 31/61,5	65 3 450 31/62,7	76 4 370 31/67,1	93 5 300 31/67,1	123 6 900 31/66
	1 000	56	—	—	—	—	—	—	—	8 423 31/55,4	11,9 630 31/55,5	16,7 879 31/55,3	24,8 1 280 31/54,1	33,9 1 800 31/55,5	48,4 2 570 31/55,6	66 3 550 31/56	82 4 500 31/57,8	102 5 600 31/57,8	125 7 100 31/59,4
	900	50	—	0,6 31,5 31/49,4	0,73 40 31/51,5	1,27 67 31/49,8	1,51 80 31/49,8	2,58 140 31/51,2	5,3 280 31/49,5	7,7 412 31/50,4	11,4 615 31/50,8	16,2 875 31/51	22,4 1 250 31/52,6	31,9 1 750 31/51,8	45,6 2 500 31/51,7	62 3 450 31/52,7	78 4 370 31/52,9	94 5 300 31/52,9	125 6 900 31/52
	800	45	—	—	—	—	—	—	—	7,9 425 31/45,1	11,9 630 31/44,4	17 900 31/44,2	23,6 1 280 31/45,4	32,3 1 800 31/46,6	46,1 2 570 31/46,7	63 3 550 31/47,1	83 4 500 31/45,5	103 5 600 31/45,5	127 7 100 31/46,8
	710	40	—	0,57 31,5 31/40,8	0,68 38,7 31/42,5	1,14 67 31/43,6	1,32 78 31/43,6	2,66 140 31/39,1	5,1 280 31/40,8	8,1 424 31/38,7	12,2 630 31/38,5	16,4 880 31/39,9	22,9 1 280 31/41,5	33,1 1 800 31/40,4	45 2 570 31/42,4	64 3 550 31/41,2	82 4 500 31/40,7	102 5 600 31/40,7	125 7 100 31/42,3
	560	28	—	0,53 30 31/33,5	0,56 33,5 31/34,9	1,2 67 31/32,8	1,34 75 31/32,8	2,3 128 31/32,6	4,63 265 31/33,5	7,7 425 31/32,2	11,7 630 31/31,6	15,9 891 31/32,8	23,8 1 280 31/31,5	34,5 1 800 31/30,6	44,9 2 570 31/33,5	64 3 550 31/32,5	79 4 500 31/33,5	98 5 600 31/33,5	120 7 100 31/34,7

Bei  $n_1$  größer als 1 400 min<sup>-1</sup> oder kleiner als 560 min<sup>-1</sup> s. Kap. 6 und Tabelle auf Seite 35.

For  $n_1$  higher than 1 400 min<sup>-1</sup> or lower than 560 min<sup>-1</sup>, see ch. 6 and table on page 35.



7 - Nennleistungen und Nenndrehmomente (Stirradgetriebe)  
7 - Nominal powers and torques (parallel shafts)

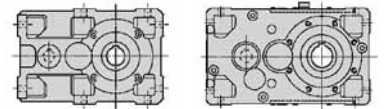

			Getriebegröße - Gear reducer size																
$n_{N2}$	$n_1$	$i_N$																	
			50	63	64	80	81	100	125	140	160	180	200	225	250	280	320	321	360
			$P_{N2}$ kW $M_{N2}$ daN m ... / i																
16	1 400	90	—	—	—	—	—	—	—	7 425 31/89,4	9,9 630 31/93,7	13,2 840 31/93,3	21,7 1 280 31/86,4	29,7 1 800 31/88,8	42,3 2 570 31/89	58 3 550 31/89,7	73 4 500 31/90,1	91 5 600 31/90,1	112 7 100 31/92,7
	1 250	80	—	0,474 27,2 31/75,2	0,56 33,5 31/78,2	0,92 58 31/82,7	1,06 67 31/82,7	2,12 122 31/75,5	4,22 243 31/75,3	6,6 412 31/81,4	9,4 615 31/85,7	13,3 875 31/86,1	19,5 1 250 31/84	27,7 1 750 31/82,7	39,6 2 500 31/82,7	54 3 450 31/84,3	69 4 370 31/82,5	84 5 300 31/81,1	111 6 900 31/81,1
	1 120	71	—	—	—	—	—	—	—	6,9 425 31/72,8	9,9 630 31/74,9	14,1 900 31/74,6	20,7 1 280 31/72,6	28,3 1 800 31/74,5	40,3 2 570 31/74,7	55 3 550 31/75,3	74 4 500 31/71	93 5 600 31/71	114 7 100 31/73
	1 000	63	—	0,55 31,5 31/60,1	0,65 38,7 31/62,6	1,06 67 31/66,3	1,22 78 31/66,3	2,39 140 31/61,5	4,87 280 31/60,2	7 412 31/62	10,1 615 31/63,5	14,4 875 31/63,8	20,9 1 250 31/62,6	29,7 1 750 31/61,7	42,5 2 500 31/61,5	58 3 450 31/62,7	68 4 370 31/67,1	83 5 300 31/67,1	109 6 900 31/66
	900	56	—	—	—	—	—	—	—	7,2 425 31/55,4	10,7 630 31/55,5	15,1 884 31/55,3	22,3 1 280 31/54,1	30,5 1 800 31/55,5	43,5 2 570 31/55,6	60 3 550 31/56	73 4 500 31/57,8	91 5 600 31/57,8	113 7 100 31/59,4
	800	50	—	0,53 31,5 31/49,4	0,65 40 31/51,5	1,13 67 31/49,8	1,34 80 31/49,8	2,29 140 31/51,2	4,74 280 31/49,5	6,8 412 31/50,4	10,1 615 31/50,8	14,4 875 31/51	19,9 1 250 31/52,6	28,3 1 750 31/51,8	40,5 2 500 31/51,7	55 3 450 31/52,7	69 4 370 31/52,9	84 5 300 31/52,9	111 6 900 31/52
	710	45	—	—	—	—	—	—	—	7 425 31/45,1	10,5 630 31/44,4	15,1 900 31/44,2	21 1 280 31/45,4	28,7 1 800 31/46,6	40,9 2 570 31/46,7	56 3 550 31/47,1	74 4 500 31/45,5	92 5 600 31/45,5	113 7 100 31/46,8
	630	40	—	0,51 31,5 31/40,8	0,6 38,7 31/42,5	1,01 67 31/43,6	1,17 78 31/43,6	2,36 140 31/39,1	4,52 280 31/40,8	7,3 425 31/38,7	10,8 630 31/38,5	14,6 886 31/39,9	20,3 1 280 31/41,5	29,4 1 800 31/40,4	39,9 2 570 31/42,4	57 3 550 31/41,2	73 4 500 31/40,7	91 5 600 31/40,7	111 7 100 31/42,3
	560	35,5	—	—	—	—	—	—	—	6,6 425 31/37,5	10,1 630 31/36,5	14,5 900 31/36,3	21,8 1 280 31/34,4	29,9 1 800 31/35,4	40,8 2 570 31/36,9	56 3 550 31/37,2	71 4 500 31/37,4	88 5 600 31/37,4	108 7 100 31/38,4
	14	1 400	100	—	—	—	—	—	2 140 31/103	4,08 280 31/101	6 412 31/100	8,4 615 31/107	11,9 875 31/108	18,3 1 250 31/100	26 1 750 31/98,5	37,2 2 500 31/98,5	50 3 450 31/100	61 4 370 31/105	74 5 300 31/105
1 250		90	—	—	—	—	—	—	—	6,2 425 31/89,4	8,8 630 31/93,7	11,9 845 31/93,3	19,4 1 280 31/86,4	26,5 1 800 31/88,8	37,8 2 570 31/89	52 3 550 31/89,7	65 4 500 31/90,1	81 5 600 31/90,1	100 7 100 31/92,7
1 120		80	—	0,424 27,2 31/75,2	0,5 33,5 31/78,2	0,82 58 31/82,7	0,95 67 31/82,7	1,9 122 31/75,5	3,79 243 31/75,3	5,9 412 31/81,4	8,4 615 31/85,7	11,9 875 31/86,1	17,5 1 250 31/84	24,8 1 750 31/82,7	35,5 2 500 31/82,7	48,7 3 450 31/84,3	62 4 370 31/82,5	75 5 300 31/82,5	100 6 900 31/81,1
1 000		71	—	—	—	—	—	—	—	6,1 425 31/72,8	8,8 630 31/74,9	12,6 900 31/74,6	18,5 1 280 31/72,6	25,3 1 800 31/74,5	36 2 570 31/74,7	49,4 3 550 31/75,3	66 4 500 31/71	83 5 600 31/71	102 7 100 31/73
900		63	—	0,494 31,5 31/60,1	0,58 38,7 31/62,6	0,95 67 31/66,3	1,1 78 31/66,3	2,15 140 31/61,5	4,38 280 31/60,2	6,3 412 31/62	9,1 615 31/63,5	12,9 875 31/63,8	18,8 1 250 31/62,6	26,7 1 750 31/61,7	38,3 2 500 31/61,5	52 3 450 31/62,7	61 4 370 31/67,1	74 5 300 31/67,1	99 6 900 31/66
800		56	—	—	—	—	—	—	—	6,4 425 31/55,4	9,5 630 31/55,5	13,5 890 31/55,3	19,8 1 280 31/54,1	27,1 1 800 31/55,5	38,7 2 570 31/55,6	53 3 550 31/56	65 4 500 31/57,8	81 5 600 31/57,8	100 7 100 31/59,4
710		50	—	0,474 31,5 31/49,4	0,58 40 31/51,5	1 67 31/49,8	1,19 80 31/49,8	2,03 140 31/51,2	4,21 280 31/49,5	6,1 412 31/50,4	9 615 31/50,8	12,7 875 31/51	17,7 1 250 31/52,6	25,1 1 750 31/51,8	36 2 500 31/51,7	48,7 3 450 31/52,7	61 4 370 31/52,9	75 5 300 31/52,9	99 6 900 31/52
630		45	—	—	—	—	—	—	—	6,2 425 31/45,1	9,4 630 31/44,4	13,4 900 31/44,2	18,6 1 280 31/45,4	25,5 1 800 31/46,6	36,3 2 570 31/46,7	49,8 3 550 31/47,1	65 4 500 31/45,5	81 5 600 31/45,5	100 7 100 31/46,8
560		40	—	0,453 31,5 31/40,8	0,53 38,7 31/42,5	0,9 67 31/43,6	1,04 78 31/43,6	2,1 140 31/39,1	4,02 280 31/40,8	6,4 425 31/38,7	9,6 630 31/38,5	13,1 891 31/39,9	18,1 1 280 31/41,5	26,1 1 800 31/40,4	35,5 2 570 31/42,4	51 3 550 31/41,2	65 4 500 31/40,7	81 5 600 31/40,7	99 7 100 31/42,3
11,2		1 400	125	—	—	—	—	—	1,66 140 31/123	3,35 280 31/123	4,24 355 31/123	6,1 530 31/128	8,4 750 31/131	13,4 1 090 31/119	17,9 1 500 31/123	25,6 2 180 31/125	35,7 3 000 31/123	43,4 3 750 31/127	52 4 500 31/127
	1 120	100	—	—	—	—	—	1,6 140 31/103	3,26 280 31/101	4,83 412 31/100	6,7 615 31/107	9,5 875 31/108	14,7 1 250 31/100	20,8 1 750 31/98,5	29,8 2 500 31/98,5	40,3 3 450 31/105	48,9 4 370 31/105	59 5 300 31/105	79 6 900 31/103
	1 000	90	—	—	—	—	—	—	—	4,98 425 31/89,4	7 630 31/93,7	9,6 854 31/93,3	15,5 1 280 31/86,4	21,2 1 800 31/88,8	30,2 2 570 31/89	41,5 3 550 31/89,7	52 4 500 31/90,1	65 5 600 31/90,1	80 7 100 31/92,7
	900	80	—	0,341 27,2 31/75,2	0,404 33,5 31/78,2	0,66 58 31/82,7	0,76 67 31/82,7	1,52 122 31/75,5	3,04 243 31/75,3	4,77 412 31/81,4	6,8 615 31/85,7	9,6 875 31/86,1	14 1 250 31/84	19,9 1 750 31/82,7	28,5 2 500 31/82,7	38,6 3 450 31/84,3	49,9 4 370 31/82,5	61 5 300 31/82,5	80 6 900 31/81,1
	800	71	—	—	—	—	—	—	—	4,89 425 31/72,8	7 630 31/74,9	10,1 900 31/74,6	14,8 1 280 31/72,6	20,2 1 800 31/74,5	28,8 2 570 31/74,7	39,5 3 550 31/75,3	53 4 500 31/71	66 5 600 31/71	81 7 100 31/73

Bei  $n_1$  größer als 1 400 min<sup>-1</sup> oder kleiner als 560 min<sup>-1</sup> s. Kap. 6 und Tabelle auf Seite 35.

For  $n_1$  higher than 1 400 min<sup>-1</sup> or lower than 560 min<sup>-1</sup>, see ch. 6 and table on page 35.

7 - Nennleistungen und Nenndrehmomente (Stirnradgetriebe)  
 7 - Nominal powers and torques (parallel shafts)

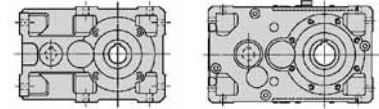

$n_{N2}$   $n_1$   $i_N$ min <sup>-1</sup>			Getriebegröße - Gear reducer size																
			50	63	64	80	81	100	125	140	160	180	200	225	250	280	320	321	360
			$P_{N2}$ kW $M_{N2}$ daNm ... // i																
11,2	710	63	—	0,389 31,5 31/60,1	0,459 38,7 31/62,6	0,75 67 31/66,3	0,87 78 31/66,3	1,69 140 31/61,5	3,46 280 31/60,2	4,94 412 31/62	7,2 615 31/63,5	10,2 875 31/63,8	14,8 1 250 31/62,6	21,1 1 750 31/61,7	30,2 2 500 31/61,5	40,9 3 450 31/62,7	48,4 4 370 31/67,1	59 5 300 31/67,1	78 6 900 31/66
	630	56	—	—	—	—	—	—	—	5,1 425 31/55,4	7,5 630 31/55,5	10,7 900 31/55,3	15,6 1 280 31/54,1	21,4 1 800 31/55,5	30,5 2 570 31/55,6	41,8 3 550 31/56	51 4 500 31/57,8	64 5 600 31/57,8	79 7 100 31/59,4
	560	50	—	0,374 31,5 31/49,4	0,455 40 31/51,5	0,79 67 31/49,8	0,94 80 31/49,8	1,6 140 31/51,2	3,32 280 31/49,5	4,79 412 31/50,4	7,1 615 31/50,8	10,1 875 31/51	13,9 1 250 31/52,6	19,8 1 750 31/51,8	28,4 2 500 31/51,7	38,4 3 450 31/52,7	48,5 4 370 31/52,9	59 5 300 31/52,9	78 6 900 31/52
9	1 400	160	—	—	—	—	—	1,18 122 31/151	2,33 243 31/153	—	—	—	—	—	—	—	—	—	—
	1 120	125	—	—	—	—	—	1,33 140 31/123	2,68 280 31/123	3,39 355 31/123	4,87 530 31/128	6,7 750 31/131	10,7 1 090 31/119	14,3 1 500 31/123	20,5 2 180 31/125	28,6 3 000 31/123	34,7 3 750 31/127	41,6 4 500 31/127	54 6 000 31/131
	900	100	—	—	—	—	—	1,28 140 31/103	2,62 280 31/101	3,88 412 31/100	5,4 615 31/107	7,7 875 31/108	11,8 1 250 31/100	16,7 1 750 31/98,5	23,9 2 500 31/98,5	32,4 3 450 31/100	39,3 4 370 31/105	47,7 5 300 31/105	63 6 900 31/103
	800	90	—	—	—	—	—	—	—	3,98 425 31/89,4	5,6 630 31/93,7	7,7 857 31/93,3	12,4 1 280 31/86,4	17 1 800 31/88,8	24,2 2 570 31/89	33,2 3 550 31/89,7	41,8 4 500 31/90,1	52 5 600 31/90,1	64 7 100 31/92,7
	710	80	—	0,269 27,2 31/75,2	0,319 33,5 31/78,2	0,52 58 31/82,7	0,6 67 31/82,7	1,2 122 31/75,5	2,4 243 31/75,3	3,76 412 31/81,4	5,3 615 31/85,7	7,6 875 31/86,1	11,1 1 250 31/84	15,7 1 750 31/82,7	22,5 2 500 31/82,7	30,4 3 450 31/84,3	39,4 4 370 31/82,5	47,8 5 300 31/82,5	63 6 900 31/81,1
	630	71	—	—	—	—	—	—	—	—	3,85 425 31/72,8	5,5 630 31/74,9	8 900 31/74,6	11,6 1 280 31/72,6	15,9 1 800 31/74,5	22,7 2 570 31/74,7	31,1 3 550 31/75,3	41,8 4 500 31/71	52 5 600 31/71
560	63	—	0,307 31,5 31/60,1	0,362 38,7 31/62,6	0,59 67 31/66,3	0,69 78 31/66,3	1,34 140 31/61,5	2,73 280 31/60,2	3,9 412 31/62	5,7 615 31/63,5	8 875 31/63,8	11,7 1 250 31/62,6	16,6 1 750 31/61,7	23,8 2 500 31/61,5	32,3 3 450 31/62,7	38,2 4 370 31/67,1	46,3 5 300 31/67,1	61 6 900 31/66	
7,1	1 120	160	—	—	—	—	—	0,94 122 31/151	1,86 243 31/153	—	—	—	—	—	—	—	—	—	—
	900	125	—	—	—	—	—	1,07 140 31/123	2,15 280 31/123	2,73 355 31/123	3,92 530 31/128	5,4 750 31/131	8,6 1 090 31/119	11,5 1 500 31/123	16,4 2 180 31/125	23 3 000 31/123	27,9 3 750 31/127	33,5 4 500 31/127	43,3 6 000 31/131
	710	100	—	—	—	—	—	1,01 140 31/103	2,07 280 31/101	3,06 412 31/100	4,27 615 31/107	6 875 31/108	9,3 1 250 31/100	13,2 1 750 31/98,5	18,9 2 500 31/98,5	25,6 3 450 31/100	31 4 370 31/105	37,6 5 300 31/105	49,8 6 900 31/103
	630	90	—	—	—	—	—	—	—	3,14 425 31/89,4	4,44 630 31/93,7	6,1 857 31/93,3	9,8 1 280 31/86,4	13,4 1 800 31/88,8	19,1 2 570 31/89	26,1 3 550 31/89,7	32,9 4 500 31/90,1	41 5 600 31/90,1	51 7 100 31/92,7
560	80	—	0,212 27,2 31/75,2	0,251 33,5 31/78,2	0,411 58 31/82,7	0,475 67 31/82,7	0,95 122 31/75,5	1,89 243 31/75,3	2,97 412 31/81,4	4,21 615 31/85,7	6 875 31/86,1	8,7 1 250 31/84	12,4 1 750 31/82,7	17,7 2 500 31/82,7	24 3 450 31/84,3	31,1 4 370 31/82,5	37,7 5 300 31/82,5	49,9 6 900 31/81,1	
5,6	900	160	—	—	—	—	—	0,76 122 31/151	1,5 243 31/153	—	—	—	—	—	—	—	—	—	—
	710	125	—	—	—	—	—	0,84 140 31/123	1,7 280 31/123	2,15 355 31/123	3,09 530 31/128	4,24 750 31/131	6,8 1 090 31/119	9,1 1 500 31/123	13 2 180 31/125	18,1 3 000 31/123	22 3 750 31/127	26,4 4 500 31/127	34,2 6 000 31/131
	560	100	—	—	—	—	—	0,8 140 31/103	1,63 280 31/101	2,42 412 31/100	3,37 615 31/107	4,77 875 31/108	7,3 1 250 31/100	10,4 1 750 31/98,5	14,9 2 500 31/98,5	20,2 3 450 31/100	24,5 4 370 31/105	29,7 5 300 31/105	39,3 6 900 31/103
4,5	710	160	—	—	—	—	—	0,6 122 31/151	1,18 243 31/153	—	—	—	—	—	—	—	—	—	—
	560	125	—	—	—	—	—	0,67 140 31/123	1,34 280 31/123	1,7 355 31/123	2,44 530 31/128	3,35 750 31/131	5,4 1 090 31/119	7,2 1 500 31/123	10,2 2 180 31/125	14,3 3 000 31/123	17,3 3 750 31/127	20,8 4 500 31/127	26,9 6 000 31/131
3,55	560	160	—	—	—	—	—	0,472 122 31/151	0,93 243 31/153	—	—	—	—	—	—	—	—	—	

Bei  $n_1$  größer als 1 400 min<sup>-1</sup> oder kleiner als 560 min<sup>-1</sup> s. Kap. 6 und Tabelle auf Seite 35.

For  $n_1$  higher than 1 400 min<sup>-1</sup> or lower than 560 min<sup>-1</sup>, see ch. 6 and table on page 35.



# 8 - Bauarten, Abmessungen, Bauformen und Ölmengen

# 8 - Designs, dimensions, mounting positions and oil quantities

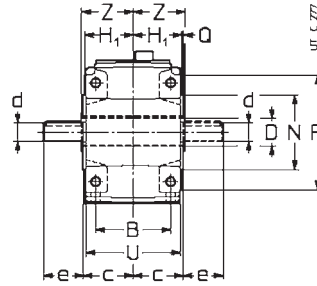
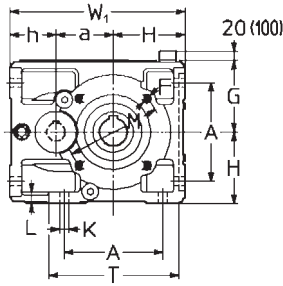

## RI 63 ... 100

**Bauart (Drehsinn)**  
**Design (direction of rotation)**

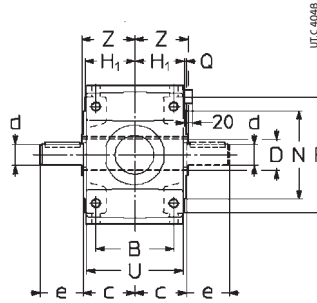
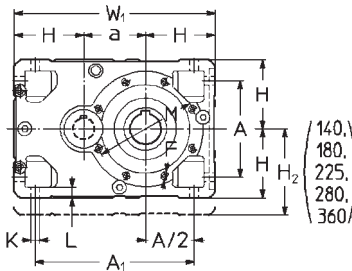
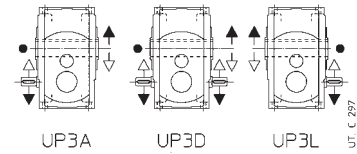

## RI 125 ... 360

**Bauart (Drehsinn)**  
**Design (direction of rotation)**

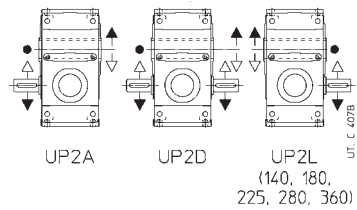

● Position der Bezugsrille (s. Kap. 20) zur Ermittlung der Radialbelastung.

● Position of the reference groove (see ch. 20) for verification of radial load.

Größe Size	a	A	A <sub>1</sub>	B	c	D Ø H7	d Ø	e	d Ø	e	F	H h11 G	H <sub>1</sub>	H <sub>2</sub> h11	h h11	K Ø	L	M Ø	N Ø h6	P Ø	Q	T	U	W <sub>1</sub>	Z	Masse Mass kg
<b>63</b>	63	102	—	90	61	30	24	50	19	40	M8	80	58,5	—	62	11,5	14	100	80	120	3	143	114	205	63	12
<b>80</b>	80	132	—	106	72	38	28	60	24	50	M10	100	69,5	—	70	14	17	130	110	160	3,5	180	135	250	75	23
<b>100</b>	100	172	—	131	87	48	32	80	28	60	M12	125	84,5	—	80	16	20	165	130	200	3,5	228	165	305	90	43
<b>125</b>	125	212	337	162	107	60	48	110	38	80	2)	150	103,5	—	18	23	215	180	250	4	—	201	425	110	84	
<b>140</b>	140	212	352	162	107	70	48	110	38 <sup>3)</sup>	80 <sup>3)</sup>	2)	150	103,5	180	—	18	23	265	230	300	4	—	201	440	125	97
<b>160</b>	160	252	412	201	132	80	55	110	48	110	M16	180	128,5	—	22	28	265	230	300	4	—	249	520	136	148	
<b>180</b>	180	252	432	201	132	90	55	110	48 <sup>3)</sup>	110 <sup>3)</sup>	M16	180	128,5	225	—	22	28	300	250	350	5	—	249	540	150	171
<b>200</b>	200	320	520	250	162	100	70	140	60	140	2)	225	158	—	27	34	350	300	400	5	—	307	650	167	262	
<b>225</b>	225	320	545	250	162	110	70	140	60 <sup>3)</sup>	140 <sup>3)</sup>	M20	225	158	280	—	27	34	400	350	450	5	—	307	675	180	303
<b>250</b>	250	396	646	310	204	125	90	170	75	140	2)	280	195	—	33	42	500	450	550	5	—	380	810	206	467	
<b>280</b>	280	396	676	310	204	140	90	170	75 <sup>3)</sup>	140 <sup>3)</sup>	M24	280	195	355	—	33	42	500	450	550	5	—	380	840	222	540
<b>320, 321</b>	320	510	830	386	256	160	110	210	95	170	2)	355	241	—	39	52	600	550	660	6	—	470	1030	254	832	
<b>360</b>	360	510	870	386	256	180	110	210	95 <sup>3)</sup>	170 <sup>3)</sup>	M30	355	241	450	—	39	52	600	550	660	6	—	470	1070	273	963

1) Nutzlänge des Gewindes 2 · F.  
2) Abmessung, Zahl und Winkelposition s. Kap. 20.  
3) Für  $h_1 = 4$ , s. Spalte  $h_1 \leq 3,15$ .

1) Working length of thread 2 · F.  
2) For dimension, number and angular position see ch. 20.  
3) For  $h_1 = 4$ , see column  $h_1 \leq 3,15$ .

## Bauformen und Ölmengen [l]

## Mounting positions and oil quantities [l]

Bauart - Design	Bauform						Größe Size	Ölmengen			
	B3	B6	B7	B8	V5	V6		B3	B8	B7	B6, V5, V6
UP3A UP3D UP3L							<b>63</b>	0,7	0,8	1	
							<b>80</b>	1,2	1,5	1,9	
							<b>100</b>	2,1	2,6	3,6	
UP2A UP2D UP2L							<b>125</b>	4,25	5,6	6,3	
							<b>140</b>	6,8	7,8	8,8	
						<b>160</b>	8	10,6	11,8		
						<b>180</b>	12,8	14,8	16,5		
						<b>200</b>	15	20	22,4		
						<b>225</b>	24	28	31,5		
						<b>250</b>	28	37,5	42,5		
						<b>280</b>	45	53	60		
						<b>320, 321</b>	53	71	80		
						<b>360</b>	85	100	112		

Falls nicht anders angegeben, werden die Getriebe in der normalen Bauform **B3** geliefert, die als solche **nicht** in der Bezeichnung aufzutreten braucht.

1) Größen 140, 180, 225, 280 und 360: Nennwärmeleistung  $P_{T_N}$  (Kap. 4) ist mit **0,85** zu multiplizieren.

☑ ggf. hohe Ölspritzleistung: Die Nennwärmeleistung  $P_{T_N}$  (Kap. 4) ist mit **0,71** (B6), **0,85** (B7) zu multiplizieren;

☑ ggf. Lagerschmierpumpe. Bei Bedarf bitte rückfragen.

Unless otherwise stated, gear reducers are supplied in mounting position **B3** which, being standard, is **omitted** from the designation.

1) Sizes 140, 180, 225, 280 and 360: nominal thermal power  $P_{T_N}$  (ch. 4) is to be multiplied by **0,85**.

☑ possible high oil-splash; nominal thermal power  $P_{T_N}$  (ch. 4) is to be multiplied by **0,71** (B6), **0,85** (B7);

☑ possible bearings lubrication pump: consult us if need be.

## 8 - Bauarten, Abmessungen, Bauformen und Ölmengen

## 8 - Designs, dimensions, mounting positions and oil quantities

R 2I 50 ... 125

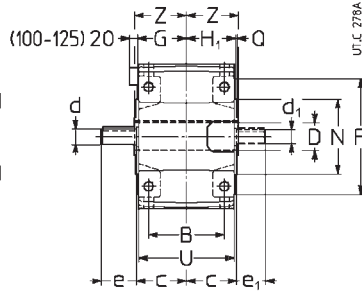
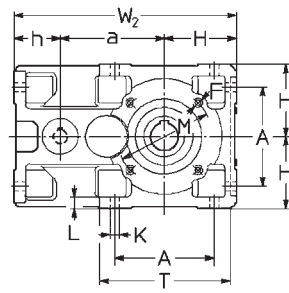
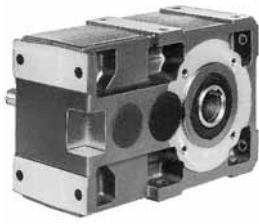

**Bauart (Drehsinn)**  
**Design (direction of rotation)**

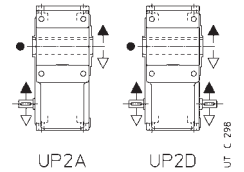

● Position der Bezugsrille (s. Kap. 20) zur Ermittlung der Radialbelastung.

● Position of the reference groove (see ch. 20) for verification of radial load.

Größe Size	a	A	B	c	D Ø H7	d Ø	e	d Ø	e	d <sub>1</sub> Ø	e <sub>1</sub>	F	H h11	H <sub>1</sub> G	h h11	K Ø	L	M Ø	N Ø h6	P Ø	Q	T	U	W <sub>2</sub>	Z	Masse Mass kg
<b>50</b>	90	86	75	51	24	16	30	14	30	14	30	M6	67	49	50	9,5	12	85	70	105	2,5	120	95	207	53	9
<b>63</b>	113	102	90	61	30	19	40	16	30	16	30	M8	80	58,5	62	11,5	14	100	80	120	3	143	114	255	63	14
<b>64</b>	115	102	90	61	32	19	40	16	30	16	30	M8	80	58,5	62	11,5	14	100	80	120	3	143	114	257	63	14
<b>80</b>	142,5	132	106	72	38	24	50	19	40	19	40	M10	100	69,5	70	14	17	130	110	160	3,5	180	135	313	75	26
<b>81</b>	142,5	132	106	72	40	24	50	19	40	19	40	M10	100	69,5	70	14	17	130	110	160	3,5	180	135	313	75	26
<b>100</b>	180	172	131	87	48	28	60	24	50	24	50	M12	125	84,5	80	16	20	165	130	200	3,5	228	165	385	90	47
<b>125</b>	225	212	162	107	60	32	80	32	80	28	60	2)	150	103,5	100	18	23	215	180	250	4	274	201	475	110	84

1) Nutzlänge des Gewindes 2 · F.  
2) Abmessung, Zahl und Winkelposition s. Kap. 20.

1) Working length of thread 2 · F.  
2) For dimension, number and angular position see ch. 20.

### Bauformen und Ölmengen [l]

### Mounting positions and oil quantities [l]

Größe Size	B3	B6	B7	B8	V5 ≥ 100	V6	B3, B8	B6	B7, V5, V6
<b>50</b>							0,6	0,9	0,8
<b>63, 64</b>							0,9	1,4	1,2
<b>80, 81</b>							1,5	2,7	2,3
<b>100</b>							2,9	5,3	4,5
<b>125</b>							5,6	9,5	8

Falls nicht anders angegeben, werden die Getriebe in der normalen Bauform **B3** geliefert, die als solche **nicht** in der Bezeichnung aufzutreten braucht.

Unless otherwise stated, gear reducers are supplied in mounting position **B3** which, being standard, is **omitted** from the designation.

⚠ ggf. Lagerschmierpumpe oder Schmiervorrichtung schnelllaufender Welle: Bei Bedarf bitte rückfragen.

⚠ possible bearings lubrication pump or high speed shaft lubrication device: consult us if need be.

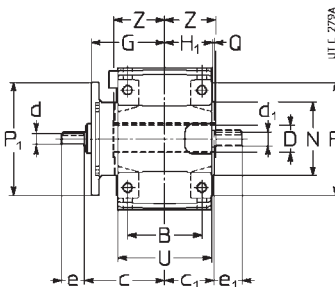
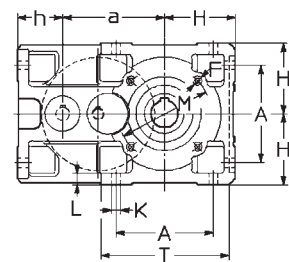
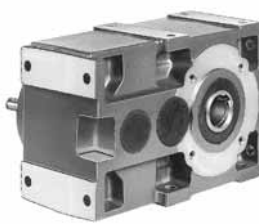

**Bauart (Drehsinn)**  
**Design (direction of rotation)**

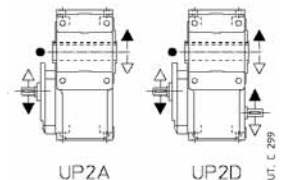

R 3I 63 ... 125

● Position der Bezugsrille (s. Kap. 20) zur Ermittlung der Radialbelastung.

● Position of the reference groove (see ch. 20) for verification of radial load.

Größe Size	a	a <sub>1</sub>	A	B	c	c <sub>1</sub>	D Ø H7	d Ø	e	d Ø	e	d <sub>1</sub> Ø	e <sub>1</sub>	F	G	H h11	H <sub>1</sub> h11	h h11	h <sub>0</sub> h11	h <sub>1</sub> h11	K Ø	L	M Ø	N Ø h6	P Ø	P <sub>1</sub> Ø	Q	T	U	W <sub>1</sub>	W <sub>2</sub>	Z	Masse Mass kg
<b>63</b>	113	40	102	90	99	61	30	11	23	—	—	16	30	M8	90	80	58,5	62	153	102	11,5	14	100	80	120	140 <sup>3)</sup>	3	143	114	40	255	63	17
<b>64</b>	115	40	102	90	99	61	32	11	23	—	—	16	30	M8	90	80	58,5	62	155	102	11,5	14	100	80	120	140 <sup>3)</sup>	3	143	114	40	257	63	17
<b>80</b>	142,5	50	132	106	117	72	38	14	30	—	—	19	40	M10	108	100	69,5	70	192,5	120	14	17	130	110	160	160 <sup>3)</sup>	3,5	180	135	50	313	75	29
<b>81</b>	142,5	50	132	106	117	72	40	14	30	—	—	19	40	M10	108	100	69,5	70	192,5	120	14	17	130	110	160	160 <sup>3)</sup>	3,5	180	135	50	313	75	29
<b>100</b>	180	63	172	131	141	87	48	19	40	16	30	24	50	M12	130	125	88,5	80	242	143	16	20	165	130	200	200	3,5	228	165	62	385	90	52
<b>125</b>	225	80	212	162	170	107	60	24	50	19	40	28	60	2)	159	150	103,5	100	295	180	18	23	215	180	250	200	4	274	201	86	475	110	92

1) Nutzlänge des Gewindes 2 · F.  
2) Abmessung, Zahl und Winkelposition s. Kap. 20.  
3) Viereckiger Flansch: Abmessungen s. Kap. 20.

1) Working length of thread 2 · F.  
2) For dimension, number and angular position see ch. 20.  
3) Square flange: for dimensions see ch. 20.

### Bauformen und Ölmengen [l]

### Mounting positions and oil quantities [l]

Größe Size	B3	B6	B7	B8	V5	V6	B3, B8	B6	B7, V5 <sup>1)</sup> , V6
<b>63, 64</b>							1	1,5	1,3
<b>80, 81</b>							1,7	2,9	2,5
<b>100</b>							3,3	5,7	4,9
<b>125</b>							6,1	10,2	8,8

Falls nicht anders angegeben, werden die Getriebe in der normalen Bauform **B3** geliefert, die als solche **nicht** in der Bezeichnung aufzutreten braucht.

Unless otherwise stated, gear reducers are supplied in mounting position **B3** which, being standard, is **omitted** from the designation.

1) Die erste Übersetzungsstufe ist mit Fett «lebensdauergeschmiert» (Menge 5% i.V. mit Öl).

1) First reduction gear pair lubricated «for life» with grease (5% oil quantity).

8 - Bauarten, Abmessungen, Bauformen und Ölmengen

8 - Designs, dimensions, mounting positions and oil quantities

R 2I, 3I 140 ...

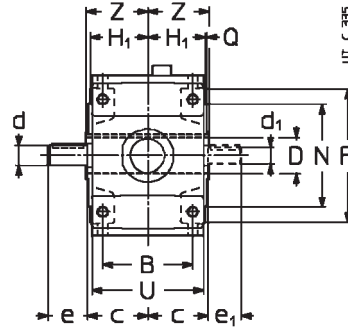
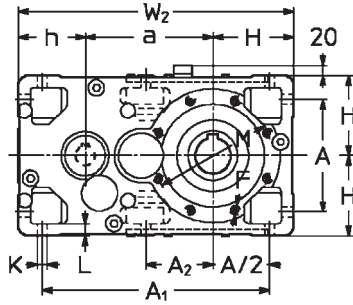

Bauart (Drehsinn)

Design (direction of rotation)

2I

3I

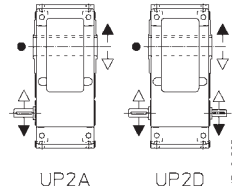
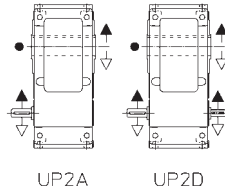

● Position der Bezugsrille (s. Kap. 20) zur Ermittlung der Radialbelastung.

● Position of the reference groove (see ch. 20) for verification of radial load.

Größe Size	a	A	A <sub>1</sub>	A <sub>2</sub>	B	c	D	d	e	d <sub>1</sub>	e <sub>1</sub>	d	e	d	e	d <sub>1</sub>	e <sub>1</sub>	F	H	H <sub>1</sub>	h	K	L	M	N	P	Q	U	W <sub>2</sub>	Z	Masse Mass
	Ø	Ø	Ø	Ø	Ø	Ø	H7	Ø	Ø	Ø	Ø	Ø	Ø	Ø	Ø	Ø	Ø	h11	h11	h11	Ø	Ø	Ø	Ø	Ø	Ø	Ø	Ø	Ø	Ø	Ø
<b>140</b>	240	212	427	127	162	107	70	32	80	28	60	28	60	24	50	24	50	2)	150	103,5	125	18	23	265	230	300	4	201	515	125	108
<b>160</b>	285	252	507	—	201	132	80	42	110	38	80	32	80	28	60	28	60	M16	180	128,5	150	22	28	265	230	300	4	249	615	136	176
<b>180</b>	305	252	527	170	201	132	90	42	110	38	80	32	80	28	60	28	60	M16	180	128,5	150	22	28	300	250	5	249	635	150	194	
<b>200</b>	360	320	635	—	250	162	100	55	110	48	110	42	110	38	80	38	80	2)	225	158	180	27	34	350	300	400	5	307	765	167	309
<b>225</b>	385	320	660	223	250	162	110	55	110	48	110	42	110	38	80	38	80	M20	225	158	180	27	34	400	350	450	5	307	790	180	340
<b>250</b>	450	396	791	—	310	200	125	70	140	55	110	55	110	48	110	48	110	2)	280	195	225	33	42	500	450	550	5	380	955	206	543
<b>280</b>	480	396	821	277	310	200	140	70	140	55	110	55	110	48	110	48	110	M24	280	195	225	33	42	500	450	550	5	380	985	222	597
<b>320, 321</b>	570	510	1005	—	386	245	160	90	170	70	140	70	140	55	110	55	110	2)	355	241	280	39	52	600	550	660	6	470	1205	254	1150
<b>360</b>	610	510	1045	358	386	245	180	90	170	70	140	70	140	55	110	55	110	M30	355	241	280	39	52	600	550	660	6	470	1245	273	1300

1) Nutzlänge des Gewindes 2 · F.  
2) Abmessung, Zahl und Winkelposition s. Kap. 20.

1) Working length of thread 2 · F.  
2) For dimension, number and angular position see ch. 20.

Bauformen und Ölmengen [l]

Mounting positions and oil quantities [l]

Größe Size	B3	B6		B8		V5	V6		B7, V5, V6
		2I	3I	2I	3I		2I	3I	
<b>140</b>	6	10,6	9,5	6	9,5	9,5			9,5
<b>160</b>	10	18	16	10	16	16			16
<b>180</b>	10,6	19	17	10,6	17	17			17
<b>200</b>	19	34	30	19	30	30			30
<b>225</b>	20	36	32	20	32	32			32
<b>250</b>	36	63	56	36	56	56			56
<b>280</b>	38	67	60	38	60	60			60
<b>320, 321</b>	67	118	106	67	106	106			106
<b>360</b>	71	126	112	71	112	112			112

Falls nicht anders angegeben, werden die Getriebe in der normalen Bauform **B3** geliefert, die als solche **nicht** in der Bezeichnung aufzutreten braucht.

Unless otherwise stated, gear reducers are supplied in mounting position **B3** which, being standard, is **omitted** from the designation.

☞ ggf. hohe Ölspritzleistung: Die Nennwärmeleistung  $P_{th}$  (Kap. 4) ist mit **0,85** (B6 oder V6), **0,71** (B7 oder V5) zu multiplizieren;

☞ possible high oil-splash; normal thermal power  $P_{th}$  (ch. 4) is to be multiplied by **0,85** (B6 or V6), **0,71** (B7 or V5);

☞ ggf. Lagerschmierpumpe oder Schmiervorrichtung schnelllaufender Welle: Bei Bedarf bitte rückfragen.

☞ possible bearings lubrication pump or high speed shaft lubrication device: consult us if need be.

8 - Bauarten, Abmessungen, Bauformen und Ölmengen

8 - Designs, dimensions, mounting positions and oil quantities

**Langes Modell - Long model  
R 2I 100, 125**

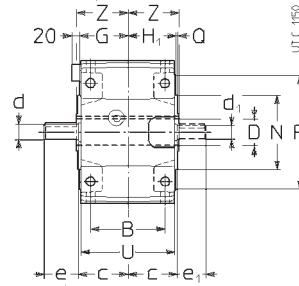
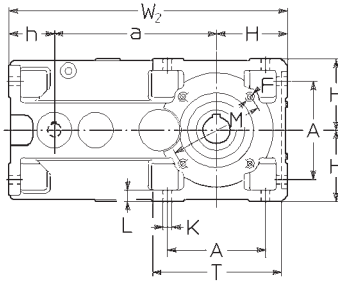
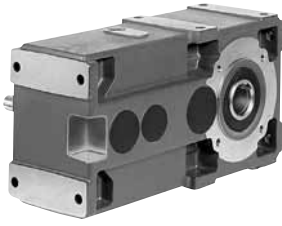

**Bauart (Drehsinn)**

**Design (direction of rotation)**

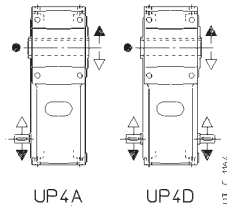

● Position der Bezugsrille (s. Kap. 20) zur Ermittlung der Radialbelastung.

● Position of the reference groove (see ch. 20 of cat. G 02) for verification of radial load.

Größe Size	a	A	B	c	D Ø H7	d Ø	e	d Ø	e	d <sub>1</sub> Ø	e <sub>1</sub>	F	H	H <sub>1</sub>	h h11	K Ø	L	M Ø	N Ø h6	P Ø	Q	T	U	W <sub>2</sub>	Z	Masse Mass kg
<b>100</b>	284,7	172	131	87	48	28	60	24	50	24	50	M12	125	84,5	80,3	16	20	165	130	200	3,5	228	165	490	90	56
<b>125</b>	358	212	162	107	60	32	80	32	80	28	60	2)	150	103,5	100	18	23	215	180	250	4	274	201	608	110	100

1) Nutzlänge des Gewindes 2 · F.  
2) Abmessung, Zahl und Winkelposition s. Kap. 20.

1) Working length of thread 2 · F.  
2) For dimension, number and angular position see ch. 20.

**Bauformen und Ölmengen [l]**

**Mounting positions and oil quantities [l]**

	B3	B6	B7	B8	V5 ⊖ ≥ 100	V6	Größe Size	B3,B8	B6	B7	V5, V6
							<b>100</b>	3,9	7,9	7,1	6,1
							<b>125</b>	7,8	14,8	13	11

Falls nicht anders angegeben, werden die Getriebe in der normalen Bauform **B3** geliefert, die als solche **nicht** in der Bezeichnung aufzutreten braucht. (s. Kap. 3).

⊖ ggf. Lageschmierpumpe oder Schmiervorrichtung schnelllaufender Welle: Bei Bedarf bitte rückfragen.

Unless otherwise stated, gear reducers are supplied in mounting position **B3** which, being standard, is **omitted** from the designation (see ch. 3).

⊖ possible bearings lubrication pump or high speed shaft lubrication device: consult us if need be.

**Langes Modell - Long model**  
**R 2I, 3I 140 ... 360**

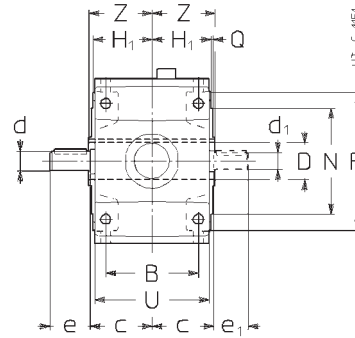
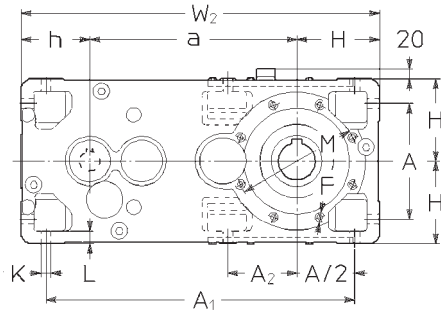
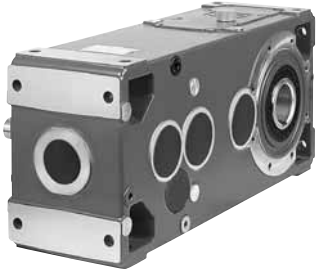

**Bauart (Drehsinn)**

**Design (direction of rotation)**

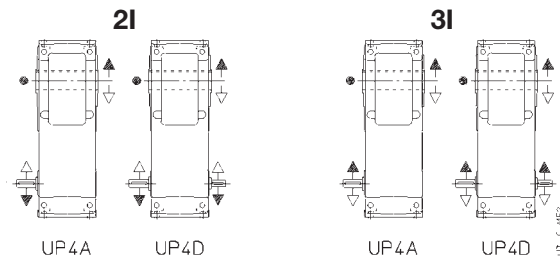

● Position der Bezugsrille (s. Kap. 20) zur Ermittlung der Radialbelastung.

● Position of the reference groove (see ch. 20) for verification of radial load.

Größe Size	a	A	A <sub>1</sub>	A <sub>2</sub>	B	c	D	d	e	d <sub>1</sub>	e <sub>1</sub>	d	e	d	e	d	e <sub>1</sub>	F	H	H <sub>1</sub>	h	K	L	M	N	P	Q	U	W <sub>2</sub>	Z	Masse Mass					
	2I																3I																			
																$i_n \leq 63$	$i_n \geq 71$																			
140	373	212	560	127	162	107	70	32	80	28	60	28	60	24	50	24	50	2)	150	103,5	125	18	23	265	230	300	4	201	648	125	124					
160	450	252	672	—	201	132	80	42	110	38	80	32	80	28	60	28	60	M16	180	128,5	150	22	28	265	230	300	4	249	780	136	204					
180	470	252	692	170	201	132	90	42	110	38	80	32	80	28	60	28	60	M16	180	128,5	150	22	28	300	250	350	5	249	800	150	222					
200	556	320	831	—	250	162	100	55	110	48	110	42	110	38	80	38	80	2)	225	158	180	27	34	350	300	400	5	307	961	167	357					
225	581	320	856	223	250	162	110	55	110	48	110	42	110	38	80	38	80	M20	225	158	180	27	34	400	350	450	5	307	986	180	389					
250	690	396	1 031	—	310	200	125	70	140	55	110	55	110	48	110	48	110	2)	280	195	225	33	42	500	450	550	5	380	1 195	206	625					
280	720	396	1 061	277	310	200	140	70	140	55	110	55	110	48	110	48	110	M24	280	195	225	33	42	500	450	550	5	380	1 225	222	682					
320, 321	870	510	1 305	—	386	245	160	90	170	70	140	70	140	55	110	55	110	2)	355	241	280	39	52	600	550	660	6	470	1 505	254	1 290					
360	910	510	1 345	358	386	245	180	90	170	70	140	70	140	55	110	55	110	M30	355	241	280	39	52	600	550	660	6	470	1 545	273	1 445					

1) Nutzlänge des Gewindes 2 · F.  
2) Abmessung, Zahl und Winkelposition s. Kap. 20.

1) Working length of thread 2 · F.  
2) For dimension, number and angular position see ch. 20.

**Bauformen und Ölmengen [l]**

**Mounting positions and oil quantities [l]**

Größe Size	B3		B6		B7		B8		V5		V6		B3	B6	B8	B7	V5, V6
	2I	3I	2I	3I	2I	3I	2I	3I	2I	3I	2I	3I	2I	3I	2I	3I	
140	8,2	16	15	8,2	12	15	13						8,2	16	15	13	
160	14	28	26	14	20	26	22						14	28	26	22	
180	15	29	27	15	21	27	23						15	29	27	23	
200	27	53	49	27	38	49	42						27	53	49	42	
225	28	55	51	28	40	51	44						28	55	51	44	
250	51	99	92	51	71	92	78						51	99	92	78	
280	53	103	96	53	75	96	82						53	103	96	82	
320, 321	94	180	168	94	133	168	146						94	180	168	146	
360	98	188	174	98	139	174	152						98	188	174	152	

Falls nicht anders angegeben, werden die Getriebe in der normalen Bauform **B3** geliefert, die als solche **nicht** in der Bezeichnung aufzutreten braucht (s. Kap. 3).

Unless otherwise stated, gear reducers are supplied in mounting position **B3** which, being standard, is **omitted** from the designation (see ch. 3).

☑ ggf. hohe Ölspritzleistung: Die Nennwärmeleistung  $P_{tn}$  (Kap. 4) ist mit **0,85** (B6 oder V6), **0,71** (B7 oder V5) zu multiplizieren;

☑ possible high oil-splash; normal thermal power  $P_{tn}$  (ch. 4) is to be multiplied by **0,85** (B6 or V6), **0,71** (B7 or V5);

☑ ggf. Lagerschmierpumpe oder Schmiervorrichtung schnelllaufender Welle: Bei Bedarf bitte rückfragen.

☑ possible bearings lubrication pump or high speed shaft lubrication device: consult us if need be.



# 9 - Nennleistungen und Nenndrehmomente (Kegelstirradgetriebe)

## 9 - Nominal powers and torques (right angle shafts)

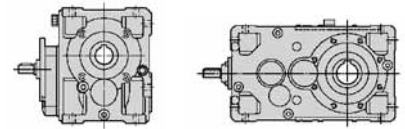

$n_{N2}$   $n_1$ min <sup>-1</sup>			$i_N$			Getriebegröße - Gear reducer size													
						50	63	64	80	81	100	125	140	160	180	200	225	250	280
<b>280</b>	1 400	5	—	—	—	—	—	—	51 176 CI/5,06	—	101 335 CI/4,89	—	201 701 CI/5,11	—	402 1 390 CI/5,06	—	718 2 400 CI/4,89▲	898 2 990 CI/4,89▲	—
			<b>224</b>	1 400	6,3	3,05 13,6 CI/6,53	5,4 24,2 CI/6,57	6,8 30,6 CI/6,57	12,2 52 CI/6,27	13,6 58 CI/6,27	24,1 107 CI/6,53	51 229 CI/6,57	—	101 430 CI/6,27	—	201 896 CI/6,53	—	402 1 800 CI/6,57	718 3 070 CI/6,27▲
	1 120	5	—			—	—	—	—	—	41,6 180 CI/5,06	—	82 343 CI/4,89	—	164 715 CI/5,11	—	328 1 420 CI/5,06	—	586 2 440 CI/4,89
<b>180</b>	1 400	8	2,96 15,8 CI/7,85	5,4 29,4 CI/8	6,8 37,2 CI/8	11,3 64 CI/8,33	13,1 75 CI/8,33	24,1 129 CI/7,85	47,7 260 CI/8	57 320 CI/8,15	92 519 CI/8,27	115 651 CI/8,31	184 1 040 CI/8,27	226 1 260 CI/8,14	345 1 930 CI/8,21	453 2 520 CI/8,15	609 3 260 CI/7,83	759 4 050 CI/7,83	898 4 900 CI/8▲
			1 120	6,3	2,47 13,7 CI/6,53	4,36 24,4 CI/6,57	5,5 30,9 CI/6,57	9,9 53 CI/6,27	11 59 CI/6,27	19,4 108 CI/6,53	41,6 233 CI/6,57	—	82 440 CI/6,27	—	164 915 CI/6,53	—	328 1 840 CI/6,57	—	586 3 130 CI/6,27
	900	5	—	—	—	—	—	—	—	34,1 183 CI/5,06	—	68 351 CI/4,89	—	135 729 CI/5,11	—	269 1 440 CI/5,06	—	480 2 490 CI/4,89	600 3 110 CI/4,89
<b>160</b>	1 400	9	—	—	—	—	—	—	—	57 353 CI/9	86 531 CI/9,04	115 732 CI/9,33	172 1 050 CI/8,93	226 1 440 CI/9,33	345 2 130 CI/9,04	453 2 780 CI/9	609 3 640 CI/8,75	759 4 530 CI/8,75	875 5 490 CI/9,2▲
			1 250	8	2,65 15,9 CI/7,85	4,84 29,6 CI/8	6,1 37,4 CI/8	10,1 65 CI/8,33	11,7 75 CI/8,33	21,6 129 CI/7,85	42,8 262 CI/8	52 323 CI/8,15	83 525 CI/8,27	104 658 CI/8,31	166 1 050 CI/8,27	204 1 270 CI/8,14	311 1 950 CI/8,21	408 2 540 CI/8,15	549 3 290 CI/7,83
	1 000	6,3	2,21 13,8 CI/6,53	3,91 24,5 CI/6,57	4,94 31 CI/6,57	8,8 53 CI/6,27	9,9 59 CI/6,27	17,4 109 CI/6,53	37,6 236 CI/6,57	—	74 445 CI/6,27	—	148 924 CI/6,53	—	296 1 860 CI/6,57	—	528 3 160 CI/6,27	660 3 950 CI/6,27	—
	800	5	—	—	—	—	—	—	—	30,7 185 CI/5,06	—	61 355 CI/4,89	—	121 737 CI/5,11	—	242 1 460 CI/5,06	—	431 2 510 CI/4,89	538 3 140 CI/4,89
<b>140</b>	1 400	10	2,16 15,2 CI/10,3	4,5 30,7 CI/10	5,5 37,5 CI/10	9,1 65 CI/10,4	10,6 75 CI/10,4	19,7 132 CI/9,81	38,6 263 CI/10	48,8 340 CI/10,2	75 530 CI/10,3	98 692 CI/10,4	150 1 060 CI/10,3	193 1 340 CI/10,2	309 2 110 CI/10	385 2 680 CI/10,2	542 3 760 CI/10,2	663 4 600 CI/10,2	759 5 170 CI/10
			1 250	9	—	—	—	—	—	—	52 356 CI/9	78 537 CI/9,04	104 739 CI/9,33	155 1 060 CI/8,93	204 1 460 CI/9,33	311 2 150 CI/9,04	408 2 810 CI/9	549 3 670 CI/8,75	685 4 580 CI/8,75
	1 120	8	2,38 15,9 CI/7,85	4,36 29,7 CI/8	5,5 37,5 CI/8	9,1 65 CI/8,33	10,6 75 CI/8,33	19,4 130 CI/7,85	38,6 263 CI/8	46,9 326 CI/8,15	75 530 CI/8,27	94 665 CI/8,31	150 1 060 CI/8,27	185 1 280 CI/8,14	281 1 970 CI/8,21	370 2 570 CI/8,15	496 3 320 CI/7,83	620 4 140 CI/7,83	732 5 000 CI/8
	900	6,3	2 13,9 CI/6,53	3,54 24,7 CI/6,57	4,46 31,1 CI/6,57	8 53 CI/6,27	8,9 59 CI/6,27	15,8 109 CI/6,53	34,1 238 CI/6,57	—	68 450 CI/6,27	—	135 932 CI/6,53	—	269 1 880 CI/6,57	—	480 3 190 CI/6,27	600 3 990 CI/6,27	—
	710	5	—	—	—	—	—	—	—	27,5 187 CI/5,06	—	55 359 CI/4,89	—	108 745 CI/5,11	—	217 1 470 CI/5,06	—	386 2 540 CI/4,89	482 3 170 CI/4,89
<b>125</b>	1 400	11,2	—	—	—	—	—	—	—	47,4 364 CI/11,3	64 496 CI/11,4	97 772 CI/11,7	128 980 CI/11,3	193 1 530 CI/11,7	255 1 980 CI/11,4	385 2 960 CI/11,3	456 3 430 CI/11	569 4 290 CI/11	714 5 600 CI/11,5
			1 250	10	1,94 15,3 CI/10,3	4,03 30,8 CI/10	4,92 37,6 CI/10	8,2 65 CI/10,4	9,5 75 CI/10,4	17,7 133 CI/9,81	34,7 265 CI/10	44 343 CI/10,2	68 535 CI/10,3	88 699 CI/10,4	135 1 070 CI/10,3	174 1 350 CI/10,2	279 2 130 CI/10	347 2 700 CI/10,2	489 3 800 CI/10,2
	1 120	9	—	—	—	—	—	—	—	46,9 360 CI/9	70 543 CI/9,04	94 747 CI/9,33	141 1 070 CI/8,93	185 1 470 CI/9,33	281 2 170 CI/9,04	370 2 840 CI/9	496 3 700 CI/8,75	620 4 630 CI/8,75	714 5 600 CI/9,2
	1 000	8	2,14 16 CI/7,85	3,91 29,9 CI/8	4,92 37,6 CI/8	8,2 65 CI/8,33	9,5 75 CI/8,33	17,4 131 CI/7,85	34,7 265 CI/8	42,3 329 CI/8,15	68 535 CI/8,27	85 671 CI/8,31	135 1 070 CI/8,27	167 1 300 CI/8,14	253 1 990 CI/8,21	333 2 600 CI/8,15	447 3 350 CI/7,83	560 4 190 CI/7,83	660 5 040 CI/8
	800	6,3	1,79 13,9 CI/6,53	3,16 24,8 CI/6,57	3,98 31,2 CI/6,57	7,1 53 CI/6,27	8 60 CI/6,27	14,1 110 CI/6,53	30,7 240 CI/6,57	—	61 455 CI/6,27	—	121 942 CI/6,53	—	242 1 900 CI/6,57	—	431 3 220 CI/6,27	538 4 030 CI/6,27	—
630	5	—	—	—	—	—	—	—	24,6 189 CI/5,06	—	49 363 CI/4,89	—	97 752 CI/5,11	—	194 1 490 CI/5,06	—	346 2 560 CI/4,89	432 3 200 CI/4,89	—
<b>112</b>	1 400	12,5	1,9 16,1 CI/12,4	3,42 29,4 CI/12,6	4,33 37,2 CI/12,6	7,3 65 CI/13,1	8,4 76 CI/13,1	15,3 129 CI/12,4	31 267 CI/12,6	36,4 320 CI/12,9	64 567 CI/13	73 651 CI/13,1	128 1 130 CI/13	143 1 260 CI/12,8	255 2 200 CI/12,6	287 2 520 CI/12,9	389 3 410 CI/12,8	476 4 170 CI/12,8	569 4 900 CI/12,6
			1 250	11,2	—	—	—	—	—	—	—	42,6 366 CI/11,3	58 502 CI/11,4	87 778 CI/11,7	115 990 CI/11,3	174 1 550 CI/11,7	230 2 010 CI/11,4	347 2 980 CI/11,3	411 3 460 CI/11

Bei  $n_1$  größer als 1 400 min<sup>-1</sup> oder kleiner als 560 min<sup>-1</sup> s. Kap. 6 und Tabelle auf Seite 54.  
▲ Eventuelle Zwangsschmierung mit Wärmeaustauscher: Bitte rückfragen.

For  $n_1$  higher than 1 400 min<sup>-1</sup> or lower than 560 min<sup>-1</sup>, see ch. 6 and table on page 54.  
▲ Possible forced lubrication with heat exchanger: consult us.

9 - Nennleistungen und Nenndrehmomente (Kegelstirradgetriebe)  
 9 - Nominal powers and torques (right angle shafts)

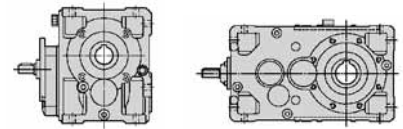

$n_{N2}$ min <sup>-1</sup>	$n_1$ min <sup>-1</sup>	$i_N$	Getriebegröße - Gear reducer size																
			50	63	64	80	81	100	125	140	160	180	200	225	250	280	320	321	360
			$P_{N2}$ kW $M_{N2}$ daN m ... / i																
112	1 120	10	1,75 15,3 CI/10,3	3,62 30,8 CI/10	4,42 37,7 CI/10	7,3 65 CI/10,4	8,5 75 CI/10,4	15,9 133 CI/9,81	31,3 267 CI/10	39,8 345 CI/10,2	61 540 CI/10,3	80 705 CI/10,4	122 1 080 CI/10,3	157 1 360 CI/10,2	252 2 150 CI/10	314 2 730 CI/10,2	442 3 830 CI/10,2	541 4 690 CI/10,2	620 5 290 CI/10
	1 000	9	—	—	—	—	—	—	—	42,3 364 CI/9	64 549 CI/9,04	85 754 CI/9,33	127 1 080 CI/8,93	167 1 490 CI/9,33	253 2 190 CI/9,04	333 2 870 CI/9	447 3 740 CI/8,75	560 4 680 CI/8,75	644 5 660 CI/9,2
	900	8	1,93 16,1 CI/7,85	3,54 30 CI/8	4,44 37,7 CI/8	7,4 65 CI/8,33	8,5 75 CI/8,33	15,8 131 CI/7,85	31,4 267 CI/8	38,4 332 CI/8,15	62 540 CI/8,27	77 678 CI/8,31	123 1 080 CI/8,27	151 1 310 CI/8,14	230 2 010 CI/8,21	303 2 620 CI/8,15	406 3 370 CI/7,83	509 4 230 CI/7,83	600 5 090 CI/8
	710	6,3	1,59 14 CI/6,53	2,82 24,9 CI/6,57	3,55 31,4 CI/6,57	6,4 54 CI/6,27	7,1 60 CI/6,27	12,6 110 CI/6,53	27,5 243 CI/6,57	—	55 460 CI/6,27	—	108 952 CI/6,53	—	217 1 920 CI/6,57	—	386 3 250 CI/6,27	482 4 070 CI/6,27	—
	560	5	—	—	—	—	—	—	22,1 191 CI/5,06	—	44,1 367 CI/4,89	—	87 760 CI/5,11	—	174 1 500 CI/5,06	—	310 2 590 CI/4,89	388 3 230 CI/4,89	—
100	1 400	14	—	—	—	—	—	—	—	36,4 353 CI/14,2	57 551 CI/14,2	73 732 CI/14,7	116 1 130 CI/14,2	143 1 440 CI/14,7	235 2 250 CI/14,1	287 2 780 CI/14,2	373 3 610 CI/14,2	443 4 290 CI/14,2	569 5 640 CI/14,5
	1 250	12,5	1,7 16,1 CI/12,4	3,07 29,6 CI/12,6	3,88 37,4 CI/12,6	6,5 65 CI/13,1	7,5 76 CI/13,1	13,7 129 CI/12,4	27,9 268 CI/12,6	32,9 323 CI/12,9	58 574 CI/13	66 658 CI/13,1	115 1 150 CI/13	129 1 270 CI/12,8	230 2 220 CI/12,6	259 2 540 CI/12,9	351 3 440 CI/12,8	430 4 210 CI/12,8	513 4 950 CI/12,6
	1 120	11,2	—	—	—	—	—	—	—	38,4 368 CI/11,3	52 508 CI/11,4	79 783 CI/11,7	104 1 000 CI/11,3	157 1 560 CI/11,7	208 2 020 CI/11,4	314 3 010 CI/11,3	372 3 500 CI/11	464 4 370 CI/11	582 5 710 CI/11,5
	1 000	10	1,57 15,4 CI/10,3	3,24 30,9 CI/10	3,96 37,8 CI/10	6,6 65 CI/10,4	7,6 76 CI/10,4	14,3 134 CI/9,81	28,1 268 CI/10	35,9 345 CI/10,2	55 545 CI/10,3	72 712 CI/10,4	110 1 090 CI/10,3	142 1 380 CI/10,2	227 2 170 CI/10	283 2 760 CI/10,2	399 3 870 CI/10,2	487 4 730 CI/10,2	560 5 350 CI/10
	900	9	—	—	—	—	—	—	—	38,4 367 CI/9	58 554 CI/9,04	77 771 CI/9,33	115 1 090 CI/8,93	151 1 500 CI/9,33	230 2 210 CI/9,04	303 2 890 CI/9	406 3 770 CI/8,75	509 4 730 CI/8,75	600 5 710 CI/9,2
	800	8	1,72 16,1 CI/7,85	3,16 30,2 CI/8	3,96 37,8 CI/8	6,6 65 CI/8,33	7,6 76 CI/8,33	14,1 132 CI/7,85	28,1 268 CI/8	34,5 336 CI/8,15	55 545 CI/8,27	69 685 CI/8,31	110 1 090 CI/8,27	136 1 320 CI/8,14	206 2 020 CI/8,21	272 2 650 CI/8,15	364 3 410 CI/7,83	458 4 280 CI/7,83	538 5 140 CI/8
630	6,3	1,42 14,1 CI/6,53	2,52 25,1 CI/6,57	3,16 31,5 CI/6,57	5,7 54 CI/6,27	6,3 60 CI/6,27	11,2 111 CI/6,53	24,6 245 CI/6,57	—	49 466 CI/6,27	—	97 962 CI/6,53	—	194 1 930 CI/6,57	—	346 3 290 CI/6,27	432 4 110 CI/6,27	—	
90	1 400	16	1,36 14,1 CI/15,2	2,47 26,5 CI/15,8	3,03 32,6 CI/15,8	5 56 CI/16,4	5,8 65 CI/16,4	11,2 116 CI/15,2	21,6 232 CI/15,8	31,4 337 CI/15,8	47,8 506 CI/15,5	66 715 CI/16	98 1 040 CI/15,8	130 1 420 CI/16	190 2 080 CI/15,8	265 2 850 CI/16,3	305 3 390 CI/16,3	381 4 220 CI/16,3	497 5 420 CI/16
	1 250	14	—	—	—	—	—	—	—	32,9 356 CI/14,2	51 555 CI/14,7	66 739 CI/14,7	105 1 130 CI/14,7	129 1 460 CI/14,7	211 2 270 CI/14,7	259 2 810 CI/14,2	337 3 650 CI/14,2	399 4 330 CI/14,2	513 5 690 CI/14,5
	1 120	12,5	1,53 16,2 CI/12,4	2,76 29,7 CI/12,6	3,49 37,6 CI/12,6	5,9 66 CI/13,1	6,8 76 CI/13,1	12,3 130 CI/12,4	25,1 270 CI/12,6	29,7 326 CI/12,9	52 580 CI/13	59 665 CI/13,1	104 1 160 CI/13	117 1 280 CI/12,8	208 2 240 CI/12,6	234 2 570 CI/12,9	317 3 470 CI/12,8	389 4 250 CI/12,8	464 5 000 CI/12,6
	1 000	11,2	—	—	—	—	—	—	—	34,5 371 CI/11,3	47,1 513 CI/11,4	71 788 CI/11,7	94 1 010 CI/11,3	141 1 570 CI/11,7	188 2 050 CI/11,4	283 3 040 CI/11,3	335 3 530 CI/11	419 4 410 CI/11	525 5 770 CI/11,5
	900	10	1,41 15,5 CI/10,3	2,92 31 CI/10	3,58 38 CI/10	5,9 66 CI/10,4	6,9 76 CI/10,4	13 135 CI/9,81	25,4 270 CI/10	32,6 345 CI/10,2	50 550 CI/10,3	65 718 CI/10,4	100 1 100 CI/10,3	129 1 390 CI/10,2	206 2 190 CI/10	257 2 780 CI/10,2	362 3 910 CI/10,2	442 4 770 CI/10,2	509 5 400 CI/10
	800	9	—	—	—	—	—	—	—	34,5 371 CI/9	52 560 CI/9,04	69 769 CI/9,33	103 1 100 CI/8,93	136 1 520 CI/9,33	206 2 230 CI/9,04	272 2 920 CI/9	364 3 800 CI/8,75	458 4 780 CI/8,75	525 5 770 CI/9,2
710	8	1,53 16,2 CI/7,85	2,82 30,4 CI/8	3,53 38 CI/8	5,9 66 CI/8,33	6,8 76 CI/8,33	12,6 133 CI/7,85	25,1 270 CI/8	29,7 339 CI/8,15	52 591 CI/8,27	62 692 CI/8,31	99 1 100 CI/8,27	122 1 340 CI/8,14	185 2 040 CI/8,21	244 2 680 CI/8,15	326 3 440 CI/7,83	411 4 330 CI/7,83	482 5 190 CI/8	
560	6,3	1,27 14,1 CI/6,53	2,25 25,2 CI/6,57	2,83 31,7 CI/6,57	5,1 54 CI/6,27	5,7 60 CI/6,27	10 112 CI/6,53	22,1 248 CI/6,57	—	44,1 471 CI/6,27	—	87 971 CI/6,53	—	174 1 950 CI/6,57	—	310 3 320 CI/6,27	388 4 150 CI/6,27	—	
80	1 400	18	—	—	—	—	—	—	—	27,8 342 CI/18	43,8 538 CI/18	56 709 CI/18,7	87 1 070 CI/18	110 1 400 CI/18,7	175 2 130 CI/17,9	221 2 710 CI/18	267 3 280 CI/18	337 4 140 CI/18	438 5 500 CI/18,4
	1 250	16	1,22 14,2 CI/15,2	2,21 26,6 CI/15,8	2,72 32,7 CI/15,8	4,52 57 CI/16,4	5,2 65 CI/16,4	10,1 117 CI/15,2	19,4 233 CI/15,8	28,2 340 CI/15,8	42,9 509 CI/15,5	59 719 CI/16	88 1 050 CI/15,5	117 1 430 CI/16	171 2 090 CI/16	238 2 870 CI/15,8	275 3 420 CI/16,3	343 4 260 CI/16,3	446 5 450 CI/16
	1 120	14	—	—	—	—	—	—	—	29,7 360 CI/14,2	46,1 558 CI/14,2	59 747 CI/14,7	94 1 140 CI/14,7	117 1 470 CI/14,7	190 2 280 CI/14,2	234 2 840 CI/14,2	304 3 690 CI/14,2	361 4 370 CI/14,2	464 5 750 CI/14,5

Bei  $n_1$  größer als 1 400 min<sup>-1</sup> oder kleiner als 560 min<sup>-1</sup> s. Kap. 6 und Tabelle auf Seite 54.

For  $n_1$  higher than 1 400 min<sup>-1</sup> or lower than 560 min<sup>-1</sup>, see ch. 6 and table on page 54.

9 - Nennleistungen und Nenndrehmomente (Kegelstirnradgetriebe)  
 9 - Nominal powers and torques (right angle shafts)

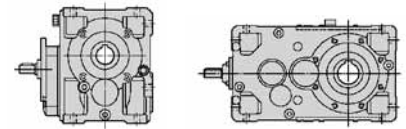

$n_{N2}$   $n_1$ min <sup>-1</sup>		$i_N$	Getriebegröße - Gear reducer size																
			50	63	64	80	81	100	125	140	160	180	200	225	250	280	320	321	360
			$P_{N2}$ kW $M_{N2}$ daN m ... / i																
80	1 000	12,5	1,37 16,2 CI/12,4	2,48 29,9 CI/12,6	3,13 37,7 CI/12,6	5,3 66 CI/13,1	6,1 76 CI/13,1	11,1 131 CI/12,4	22,6 272 CI/12,6	26,8 329 CI/12,9	47,1 587 CI/13	54 671 CI/13,1	94 1 170 CI/13	106 1 300 CI/12,8	188 2 260 CI/12,6	211 2 600 CI/12,9	286 3 500 CI/12,8	350 4 290 CI/12,8	419 5 040 CI/12,6
	900	11,2	—	—	—	—	—	—	—	31,2 373 CI/11,3	42,9 519 CI/11,4	64 793 CI/11,7	85 1 020 CI/11,3	128 1 580 CI/11,7	171 2 060 CI/11,4	257 3 070 CI/11,3	304 3 560 CI/11	380 4 450 CI/11	477 5 820 CI/11,5
	800	10	1,26 15,5 CI/10,3	2,6 31,1 CI/10	3,19 38,1 CI/10	5,3 66 CI/10,4	6,1 76 CI/10,4	11,6 136 CI/9,81	22,8 272 CI/10	29,3 345 CI/10,2	45,1 556 CI/10,3	59 725 CI/10,4	90 1 110 CI/10,3	115 1 400 CI/10,2	185 2 210 CI/10	231 2 810 CI/10,2	315 3 950 CI/10,2	397 4 820 CI/10,2	458 5 460 CI/10
	710	9	—	—	—	—	—	—	—	30,8 373 CI/9	46,6 567 CI/9,04	62 777 CI/9,33	92 1 110 CI/8,93	122 1 530 CI/9,33	185 2 250 CI/9,04	244 2 950 CI/9	326 3 840 CI/8,75	411 4 830 CI/8,75	471 5 830 CI/9,2
	630	8	1,36 16,2 CI/7,85	2,52 30,5 CI/8	3,14 38,1 CI/8	5,2 66 CI/8,33	6 76 CI/8,33	11,2 133 CI/7,85	22,4 272 CI/8	27,7 343 CI/8,15	44,4 557 CI/8,27	55 699 CI/8,31	88 1 110 CI/8,27	109 1 350 CI/8,14	166 2 060 CI/8,21	219 2 700 CI/8,15	292 3 470 CI/7,83	368 4 380 CI/7,83	432 5 240 CI/8
71	1 400	20	—	—	—	—	—	—	—	26,4 368 C21/20,4	44,4 624 C21/20,6	56 820 C21/21,4	91 1 270 C21/20,5	113 1 530 C21/19,9	174 2 550 C21/21,5	222 3 150 C21/20,8	317 4 460 C21/20,6	394 5 540 C21/20,6	443 6 460 C21/21,4
	1 400	20	1,08 14,2 CI/19,3	1,96 26,7 CI/20	2,41 32,9 CI/20	4,01 57 CI/20,8	4,63 66 CI/20,8	9 118 CI/19,3	17,2 235 CI/20	24,8 338 CI/20	38,1 512 CI/19,7	48,8 676 CI/20,3	78 1 050 CI/19,7	98 1 350 CI/20,3	152 2 110 CI/20,3	196 2 670 CI/20	257 3 450 CI/19,7	307 4 120 CI/19,7	381 5 270 CI/20,3
	1 250	18	—	—	—	—	—	—	—	24,9 342 CI/18	39,5 543 CI/18	49,7 709 CI/18,7	79 1 080 CI/18	98 1 400 CI/18,7	158 2 150 CI/17,9	197 2 710 CI/18	241 3 310 CI/18	304 4 180 CI/18	391 5 500 CI/18,4
	1 120	16	1,1 14,2 CI/15,2	1,99 26,7 CI/15,8	2,44 32,8 CI/15,8	4,06 57 CI/16,4	4,7 66 CI/16,4	9,1 118 CI/15,2	17,5 235 CI/15,8	25,4 342 CI/15,8	38,7 512 CI/15,5	53 723 CI/16	79 1 050 CI/15,5	106 1 440 CI/16	154 2 100 CI/16	214 2 880 CI/15,8	249 3 450 CI/16,3	310 4 300 CI/16,3	401 5 480 CI/16
	1 000	14	—	—	—	—	—	—	—	26,8 364 CI/14,2	41,5 562 CI/14,2	54 754 CI/14,7	85 1 150 CI/14,2	106 1 490 CI/14,7	170 2 290 CI/14,1	211 2 870 CI/14,2	275 3 720 CI/14,2	325 4 410 CI/14,2	419 5 800 CI/14,5
	900	12,5	1,24 16,3 CI/12,4	2,24 30 CI/12,6	2,83 37,9 CI/12,6	4,74 66 CI/13,1	5,5 76 CI/13,1	10 131 CI/12,4	20,4 273 CI/12,6	24,4 332 CI/12,9	42,9 593 CI/13	48,7 678 CI/13,1	85 1 180 CI/13	96 1 310 CI/12,8	171 2 280 CI/12,6	192 2 620 CI/12,9	260 3 530 CI/12,8	318 4 330 CI/12,8	380 5 090 CI/12,6
	800	11,2	—	—	—	—	—	—	—	27,9 375 CI/11,3	38,6 525 CI/11,4	57 798 CI/11,7	77 1 030 CI/11,3	114 1 590 CI/11,7	153 2 090 CI/11,4	219 3 100 CI/11,3	273 3 600 CI/11	341 4 500 CI/11	428 5 880 CI/11,5
	710	10	1,13 15,6 CI/10,3	2,32 31,2 CI/10	2,84 38,2 CI/10	4,72 66 CI/10,4	5,5 76 CI/10,4	10,4 137 CI/9,81	20,3 273 CI/10	26,2 345 CI/10,2	40,4 561 CI/10,3	52 732 CI/10,4	80 1 120 CI/10,3	103 1 420 CI/10,2	166 2 230 CI/10	207 2 840 CI/10,2	291 3 990 CI/10,2	355 4 860 CI/10,2	411 5 520 CI/10
	630	9	—	—	—	—	—	—	—	27,5 376 CI/9	41,8 573 CI/9,04	55 785 CI/9,33	83 1 120 CI/8,93	109 1 550 CI/9,33	166 2 270 CI/9,04	219 2 980 CI/9	292 3 880 CI/8,75	368 4 890 CI/8,75	422 5 880 CI/9,2
	560	8	1,22 16,3 CI/7,85	2,25 30,7 CI/8	2,8 38,2 CI/8	4,65 66 CI/8,33	5,4 77 CI/8,33	10 134 CI/7,85	20 274 CI/8	24,9 346 CI/8,15	39,9 562 CI/8,27	49,8 706 CI/8,31	79 1 120 CI/8,27	98 1 360 CI/8,14	149 2 080 CI/8,21	196 2 730 CI/8,15	262 3 500 CI/7,83	331 4 420 CI/7,83	388 5 290 CI/8
63	1 400	22,4	—	—	—	—	—	—	—	25,9 421 C21/23,8	38,5 624 C21/23,8	55 892 C21/23,7	83 1 270 C21/23,8	113 1 770 C21/23	158 2 550 C21/23,6	217 3 520 C21/23,8	284 4 460 C21/23	354 5 550 C21/23	436 7 030 C21/23,7
	1 250	20	—	—	—	—	—	—	—	23,7 370 C21/20,4	39,9 628 C21/20,6	51 829 C21/21,4	81 1 270 C21/20,5	102 1 550 C21/19,9	156 2 560 C21/21,5	200 3 180 C21/20,8	285 4 490 C21/20,6	355 5 580 C21/20,6	400 6 530 C21/21,4
	1 250	20	0,97 14,3 CI/19,3	1,75 26,8 CI/20	2,16 33 CI/20	3,59 57 CI/20,8	4,15 66 CI/20,8	8 119 CI/19,3	15,5 236 CI/20	22,4 342 CI/20	34,2 515 CI/19,7	44,1 684 CI/20,3	70 1 060 CI/19,7	88 1 370 CI/20,3	137 2 120 CI/20,3	177 2 700 CI/20	231 3 470 CI/19,7	275 4 140 CI/19,7	343 5 320 CI/20,3
	1 120	18	—	—	—	—	—	—	—	22,3 342 CI/18	35,7 548 CI/18	44,5 709 CI/18,7	71 1 090 CI/18	98 1 400 CI/18,7	143 2 170 CI/17,9	177 2 710 CI/18	218 3 340 CI/18	275 4 220 CI/18	351 5 500 CI/18,4
	1 000	16	0,98 14,3 CI/15,2	1,78 26,8 CI/15,8	2,19 32,9 CI/15,8	3,64 57 CI/16,4	4,21 66 CI/16,4	8,2 118 CI/15,2	15,7 236 CI/15,8	22,8 344 CI/15,8	34,7 515 CI/15,5	47,7 728 CI/16	71 1 060 CI/15,5	95 1 450 CI/16	138 2 120 CI/16	193 2 900 CI/15,8	224 3 490 CI/16,3	279 4 340 CI/16,3	360 5 500 CI/16
	900	14	—	—	—	—	—	—	—	24,4 367 CI/14,2	37,5 565 CI/14,2	48,7 761 CI/14,7	77 1 150 CI/14,2	96 1 500 CI/14,7	154 2 310 CI/14,1	192 2 890 CI/14,2	249 3 750 CI/14,2	295 4 450 CI/14,2	380 5 850 CI/14,5
	800	12,5	1,11 16,3 CI/12,4	2,01 30,2 CI/12,6	2,53 38 CI/12,6	4,23 66 CI/13,1	4,89 77 CI/13,1	8,9 132 CI/12,4	18,3 275 CI/12,6	21,9 336 CI/12,9	38,6 600 CI/13	43,8 685 CI/13,1	77 1 190 CI/13	86 1 320 CI/12,8	153 2 310 CI/12,6	172 2 650 CI/12,9	233 3 570 CI/12,8	286 4 370 CI/12,8	341 5 140 CI/12,6
710	11,2	—	—	—	—	—	—	—	25 378 CI/11,3	34,6 531 CI/11,4	51 804 CI/11,7	69 1 040 CI/11,3	102 1 610 CI/11,4	137 3 130 CI/11,3	207 3 630 CI/11	245 4 540 CI/11	306 5 940 CI/11	384 5 940 CI/11,5	

Bei  $n_1$  größer als 1 400 min<sup>-1</sup> oder kleiner als 560 min<sup>-1</sup> s. Kap. 6 und Tabelle auf Seite 54.

For  $n_1$  higher than 1 400 min<sup>-1</sup> or lower than 560 min<sup>-1</sup>, see ch. 6 and table on page 54.

9 - Nennleistungen und Nenndrehmomente (Kegelstirnradgetriebe)  
 9 - Nominal powers and torques (right angle shafts)

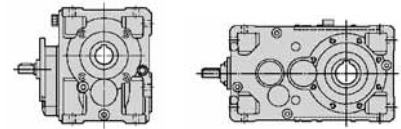

		Getriebegröße - Gear reducer size																																
$n_{N2}$	$n_1$	$i_N$																	$P_{N2}$ kW															
																			$M_{N2}$ daNm															
																		... / i																
																		50	63	64	80	81	100	125	140	160	180	200	225	250	280	320	321	360
63	630	10	1 15,7 CI/10,3	2,06 31,3 CI/10	2,53 38,3 CI/10	4,2 66 CI/10,4	4,86 77 CI/10,4	9,3 138 CI/9,81	18,1 275 CI/10	23,5 345 CI/10,2	36,2 567 CI/10,3	47 739 CI/10,4	72 1 130 CI/10,3	93 1 430 CI/10,2	148 2 250 CI/10	185 2 860 CI/10,2	261 4 030 CI/10,2	318 4 910 CI/10,2	368 5 590 CI/10															
	560	9	—	—	—	—	—	—	—	24,6 378 CI/9	37,5 579 CI/9,04	49,8 793 CI/9,33	74 1 130 CI/8,93	98 1 560 CI/9,33	149 2 290 CI/9,04	196 3 010 CI/9	262 3 910 CI/8,75	331 4 940 CI/8,75	379 5 940 CI/9,2															
56	1 400	25	—	—	—	—	—	—	—	23,8 398 C21/24,5	36,8 630 C21/25,1	46,7 829 C21/26	69 1 280 C21/27	99 1 770 C21/26,3	139 2 570 C21/27,2	198 3 550 C21/26,4	263 4 500 C21/25,1	328 5 600 C21/25,1	400 7 100 C21/26															
	1 400	25	0,87 14,3 CI/24,1	1,48 25,2 CI/25	1,87 31,9 CI/25	3,23 57 CI/26	3,68 65 CI/26	6,6 109 CI/24,1	13,9 238 CI/25	—	28 470 CI/24,6	—	56 941 CI/24,6	—	111 1 930 CI/25,4	—	—	—	—	—														
	1 250	22,4	—	—	—	—	—	—	—	23,3 424 C21/23,8	34,6 628 C21/23,8	49,6 897 C21/23,7	74 1 270 C21/22,4	102 1 780 C21/23	142 2 560 C21/23,6	195 3 540 C21/23,8	255 4 490 C21/23	318 5 580 C21/23	392 7 080 C21/23,7															
	1 120	20	—	—	—	—	—	—	—	21,3 371 C21/20,4	35,9 630 C21/20,6	46 837 C21/21,4	73 1 280 C21/20,5	92 1 560 C21/19,9	140 2 570 C21/21,5	181 3 210 C21/20,8	256 4 500 C21/20,6	319 5 600 C21/20,6	362 6 590 C21/21,4															
	1 120	20	0,87 14,3 CI/19,3	1,58 26,9 CI/20	1,94 33,1 CI/20	3,23 57 CI/20,8	3,73 66 CI/20,8	7,3 119 CI/19,3	13,9 238 CI/20	20,2 345 CI/20	30,9 518 CI/19,7	40 691 CI/20,3	63 1 070 CI/19,7	80 1 380 CI/20,3	123 2 130 CI/20,3	160 2 730 CI/20	208 3 490 CI/19,7	248 4 160 CI/19,7	310 5 370 CI/20,3															
	1 000	18	—	—	—	—	—	—	—	19,9 342 CI/18	32,2 553 CI/18	39,8 709 CI/18,7	64 1 100 CI/18	79 1 400 CI/18,7	129 2 190 CI/17,9	158 2 710 CI/18	196 3 370 CI/18	248 4 260 CI/18	313 5 500 CI/18,4															
	900	16	0,89 14,3 CI/15,2	1,61 26,9 CI/15,8	1,98 33,1 CI/15,8	3,29 57 CI/16,4	3,8 66 CI/16,4	7,4 119 CI/15,2	14,2 237 CI/15,8	20,7 346 CI/15,8	31,4 518 CI/15,5	43,1 732 CI/16	65 1 060 CI/15,5	86 1 460 CI/16	125 2 130 CI/16	175 2 920 CI/15,8	204 3 520 CI/16,3	254 4 380 CI/16,3	326 5 530 CI/16															
	800	14	—	—	—	—	—	—	—	21,9 371 CI/14,2	33,6 569 CI/14,2	43,8 769 CI/14,7	68 1 160 CI/14,2	86 1 520 CI/14,7	138 2 320 CI/14,1	172 2 920 CI/14,2	224 3 790 CI/14,2	265 4 490 CI/14,2	341 5 910 CI/14,5															
	710	12,5	0,98 16,4 CI/12,4	1,79 30,4 CI/12,6	2,25 38,2 CI/12,6	3,77 67 CI/13,1	4,36 77 CI/13,1	8 133 CI/12,4	16,3 277 CI/12,6	19,6 339 CI/12,9	34,6 607 CI/13	39,2 692 CI/13,1	69 1 200 CI/13	77 1 340 CI/12,8	137 2 330 CI/12,6	155 2 680 CI/12,9	209 3 600 CI/12,8	256 4 420 CI/12,8	306 5 190 CI/12,6															
	630	11,2	—	—	—	—	—	—	—	22,3 380 CI/11,3	31,1 537 CI/11,4	45,8 809 CI/11,7	62 1 050 CI/11,3	91 1 620 CI/11,7	123 2 130 CI/11,4	185 3 160 CI/11,3	219 3 670 CI/11	274 4 590 CI/11	344 5 990 CI/11,5															
560	10	0,9 15,7 CI/10,3	1,84 31,3 CI/10	2,26 38,5 CI/10	3,75 67 CI/10,4	4,34 77 CI/10,4	8,3 138 CI/9,81	16,2 277 CI/10	21,1 345 CI/10,2	32,5 572 CI/10,3	42,1 746 CI/10,4	65 1 140 CI/10,3	83 1 440 CI/10,2	133 2 270 CI/10	166 2 890 CI/10,2	234 4 060 CI/10,2	286 4 950 CI/10,2	331 5 650 CI/10																
50	1 400	28	—	—	—	—	—	—	—	21,8 425 C21/28,6	31,9 630 C21/28,9	45,8 900 C21/28,8	64 1 280 C21/29,5	87 1 800 C21/30,3	126 2 570 C21/29,9	173 3 550 C21/30,1	236 4 500 C21/28	293 5 600 C21/28	361 7 100 C21/28,8															
	1 250	25	—	—	—	—	—	—	—	21,4 401 C21/24,5	32,9 630 C21/25,1	42 834 C21/26	62 1 280 C21/27	89 1 780 C21/26,3	124 2 570 C21/27,2	176 3 550 C21/26,4	235 4 500 C21/25,1	292 5 600 C21/25,1	357 7 100 C21/26															
	1 250	25	0,78 14,4 CI/24,1	1,33 25,4 CI/25	1,68 32 CI/25	2,89 57 CI/26	3,3 66 CI/26	5,9 109 CI/24,1	12,5 239 CI/25	—	25,3 475 CI/24,6	—	51 950 CI/24,6	—	100 1 950 CI/25,4	—	—	—	—	—														
	1 120	22,4	—	—	—	—	—	—	—	20,9 425 C21/23,8	31,1 630 C21/23,8	44,6 900 C21/23,7	67 1 280 C21/22,4	92 1 800 C21/23	128 2 570 C21/23,6	175 3 550 C21/23,8	229 4 500 C21/23	286 5 600 C21/23	352 7 100 C21/23,7															
	1 000	20	—	—	—	—	—	—	—	19,2 374 C21/20,4	32 630 C21/20,6	41,4 844 C21/21,4	65 1 280 C21/20,5	83 1 580 C21/19,9	125 2 570 C21/21,5	163 3 250 C21/20,8	229 4 500 C21/20,6	285 5 600 C21/20,6	327 6 660 C21/21,4															
	1 000	20	0,78 14,4 CI/19,3	1,41 27 CI/20	1,74 33,2 CI/20	2,89 57 CI/20,8	3,34 66 CI/20,8	6,5 120 CI/19,3	12,5 239 CI/20	18,2 348 CI/20	27,7 521 CI/19,7	36,1 699 CI/20,3	57 1 070 CI/19,7	72 1 390 CI/20,3	111 2 140 CI/20,3	144 2 760 CI/20	186 3 500 CI/19,7	222 4 180 CI/19,7	279 5 410 CI/20,3															
	900	18	—	—	—	—	—	—	—	17,9 342 CI/18	29,2 558 CI/18	35,8 709 CI/18,7	58 1 110 CI/18	71 1 400 CI/18,7	117 2 210 CI/17,9	142 2 710 CI/18	178 3 400 CI/18	225 4 300 CI/18	282 5 500 CI/18,4															
	800	16	0,79 14,3 CI/15,2	1,43 26,9 CI/15,8	1,76 33,2 CI/15,8	2,93 57 CI/16,4	3,39 66 CI/16,4	6,6 120 CI/15,2	12,7 239 CI/15,8	18,5 348 CI/15,8	28,1 521 CI/15,5	38,6 737 CI/16	58 1 070 CI/15,5	77 1 470 CI/16	112 2 140 CI/16	156 2 940 CI/15,8	183 3 550 CI/16,3	228 4 420 CI/16,3	291 5 560 CI/16															
	710	14	—	—	—	—	—	—	—	19,6 375 CI/14,2	30 573 CI/14,2	39,2 777 CI/14,7	61 1 170 CI/14,2	77 1 530 CI/14,7	123 2 330 CI/14,1	155 2 950 CI/14,2	201 3 800 CI/14,2	238 4 540 CI/14,2	306 5 970 CI/14,5															
	630	12,5	0,88 16,4 CI/12,4	1,6 30,5 CI/12,6	2,01 38,4 CI/12,6	3,35 67 CI/13,1	3,88 77 CI/13,1	7,1 133 CI/12,4	14,6 278 CI/12,6	17,6 343 CI/12,9	30,9 611 CI/13	35,2 699 CI/13,1	62 1 220 CI/13	69 1 350 CI/12,8	123 2 360 CI/12,6	139 2 700 CI/12,9	187 3 640 CI/12,8	229 4 460 CI/12,8	274 5 240 CI/12,6															

Bei  $n_1$  größer als 1 400 min<sup>-1</sup> oder kleiner als 560 min<sup>-1</sup> s. Kap. 6 und Tabelle auf Seite 54.

For  $n_1$  higher than 1 400 min<sup>-1</sup> or lower than 560 min<sup>-1</sup>, see ch. 6 and table on page 54.

9 - Nennleistungen und Nenndrehmomente (Kegelstirnradgetriebe)  
9 - Nominal powers and torques (right angle shafts)

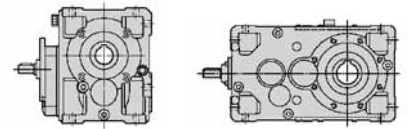

			Getriebegröße - Gear reducer size																	
$n_{N2}$	$n_1$	$i_N$	$P_{N2}$ kW $M_{N2}$ daN m ... / l																	
			50	63	64	80	81	100	125	140	160	180	200	225	250	280	320	321	360	
50	560	11,2	—	—	—	—	—	—	—	19,9 383 CI/11,3	27,9 543 CI/11,4	41 815 CI/11,7	55 1 060 CI/11,3	82 1 630 CI/11,7	111 2 150 CI/11,4	166 3 190 CI/11,3	197 3 710 CI/11	246 4 630 CI/11	309 6 050 CI/11,5	
45	1 400	31,5	—	—	—	—	—	—	—	18,9 412 C21/32	27,3 615 C21/33,1	38,6 875 C21/33,2	54 1 250 C21/34,2	76 1 750 C21/33,7	111 2 500 C21/33,1	150 3 450 C21/33,7	211 4 500 C21/31,3	262 5 600 C21/31,3	320 7 100 C21/32,5	
	1 400	31,5	0,72 15,9 ICI/32,1	1,21 27,1 ICI/33	1,42 31,9 ICI/33	2,82 60 ICI/31,4	3,09 66 ICI/31,4	5,7 127 ICI/32,8	11,6 257 ICI/32,4	—	25,4 543 ICI/31,4	—	50 1 120 ICI/32,7	—	—	—	—	—	—	—
	1 400	31,5	—	0,98 20,8 CI/31,3	1,15 24,5 CI/31,3	1,95 43,3 CI/32,5	2,37 52 CI/32,5	4,37 90 CI/30,1	8,2 174 CI/31,3	—	16,3 343 CI/30,8	—	32,2 675 CI/30,8	—	64 1 390 CI/31,7	—	—	—	—	—
	1 250	28	—	—	—	—	—	—	—	19,5 425 C21/28,6	28,5 630 C21/28,9	40,9 900 C21/28,8	57 1 280 C21/29,5	78 1 800 C21/30,3	113 2 570 C21/29,9	154 3 550 C21/30,1	210 4 500 C21/28	262 5 600 C21/28	323 7 100 C21/28,8	
	1 120	25	—	—	—	—	—	—	—	19,3 403 C21/24,5	29,5 630 C21/25,1	37,8 839 C21/26	56 1 280 C21/27	80 1 790 C21/26,3	111 2 570 C21/27,2	158 3 550 C21/26,4	211 4 500 C21/25,1	262 5 600 C21/25,1	320 7 100 C21/26	
	1 120	25	0,7 14,4 CI/24,1	1,2 25,5 CI/25	1,51 32,2 CI/25	2,6 58 CI/26	2,97 66 CI/26	5,3 110 CI/24,1	11,3 240 CI/25	—	22,8 479 CI/24,6	—	45,7 959 CI/24,6	—	91 1 970 CI/25,4	—	—	—	—	—
	1 000	22,4	—	—	—	—	—	—	—	18,7 425 C21/23,8	27,8 630 C21/23,8	39,8 900 C21/23,7	60 1 280 C21/22,4	82 1 800 C21/23	114 2 570 C21/23,6	156 3 550 C21/23,8	205 4 500 C21/23	255 5 600 C21/23	314 7 100 C21/23,7	
	900	20	—	—	—	—	—	—	—	17,3 375 C21/20,4	28,8 630 C21/20,6	37,5 849 C21/21,4	59 1 280 C21/20,5	75 1 590 C21/19,9	113 2 570 C21/21,5	148 3 280 C21/20,8	206 4 500 C21/20,6	256 5 600 C21/20,6	297 6 720 C21/21,4	
	900	20	0,7 14,4 CI/19,3	1,27 27 CI/20	1,57 33,3 CI/20	2,61 58 CI/20,8	3,02 67 CI/20,8	5,9 121 CI/19,3	11,3 240 CI/20	—	16,5 351 CI/20	25,1 524 CI/19,7	32,8 706 CI/20,3	52 1 080 CI/19,7	65 1 410 CI/20,3	100 2 160 CI/20,3	131 2 780 CI/20	168 3 520 CI/19,7	201 4 200 CI/19,7	254 5 460 CI/20,3
	800	18	—	—	—	—	—	—	—	15,9 342 CI/18	26,2 563 CI/18	31,8 709 CI/18,7	52 1 120 CI/18	63 1 400 CI/18,7	105 2 240 CI/17,9	126 2 710 CI/18	160 3 430 CI/18	202 4 340 CI/18	250 5 500 CI/18,4	
710	16	0,7 14,4 CI/15,2	1,27 27 CI/15,8	1,57 33,3 CI/15,8	2,61 58 CI/16,4	3,02 67 CI/16,4	5,9 121 CI/15,2	11,3 240 CI/15,8	—	16,5 351 CI/15,8	25,1 524 CI/15,5	34,5 741 CI/16	52 1 080 CI/15,5	69 1 480 CI/16	100 2 160 CI/16	140 2 960 CI/15,8	164 3 590 CI/16,3	204 4 460 CI/16,3	260 5 580 CI/16	
630	14	—	—	—	—	—	—	—	17,6 378 CI/14,2	26,8 577 CI/14,2	35,2 785 CI/14,7	55 1 170 CI/14,2	69 1 550 CI/14,7	110 2 350 CI/14,1	139 2 980 CI/14,2	180 3 870 CI/14,2	213 4 580 CI/14,2	274 6 030 CI/14,5		
560	12,5	0,78 16,5 CI/12,4	1,43 30,7 CI/12,6	1,79 38,5 CI/12,6	2,99 67 CI/13,1	3,46 78 CI/13,1	6,3 134 CI/12,4	13 280 CI/12,6	—	15,8 346 CI/12,9	27,7 615 CI/13	31,6 706 CI/13,1	55 1 230 CI/13	62 1 360 CI/12,8	111 2 380 CI/12,6	125 2 730 CI/12,9	168 3 670 CI/12,8	206 4 500 CI/12,8	246 5 290 CI/12,6	
40	1 400	35,5	—	—	—	—	—	—	—	16,6 425 C21/37,5	24,7 630 C21/37,5	35,4 900 C21/37,3	53 1 280 C21/35,3	71 1 770 C21/36,2	101 2 570 C21/37,2	139 3 550 C21/37,5	182 4 500 C21/36,3	226 5 600 C21/36,3	279 7 100 C21/37,3	
	1 250	31,5	—	—	—	—	—	—	—	16,9 412 C21/32	24,3 615 C21/33,2	34,5 875 C21/33,2	47,9 1 250 C21/34,2	68 1 750 C21/33,7	99 2 500 C21/33,1	134 3 450 C21/33,7	188 4 500 C21/31,3	234 5 600 C21/31,3	286 7 100 C21/32,5	
	1 250	31,5	0,65 15,9 ICI/32,1	1,08 27,3 ICI/33	1,27 32,1 ICI/33	2,54 61 ICI/31,4	2,78 67 ICI/31,4	5,1 127 ICI/32,8	10,4 257 ICI/32,4	—	22,9 548 ICI/31,4	—	45,1 1 130 ICI/32,7	—	—	—	—	—	—	—
	1 250	31,5	—	0,88 20,9 CI/31,3	1,03 24,6 CI/31,3	1,75 43,5 CI/32,5	2,12 53 CI/32,5	3,92 90 CI/30,1	7,4 176 CI/31,3	—	14,7 346 CI/30,8	—	29,1 683 CI/30,8	—	58 1 410 CI/31,7	—	—	—	—	—
	1 120	28	—	—	—	—	—	—	—	17,4 425 C21/28,6	25,5 630 C21/28,9	36,6 900 C21/28,8	51 1 280 C21/29,5	70 1 800 C21/30,3	101 2 570 C21/29,9	138 3 550 C21/30,1	188 4 500 C21/28	235 5 600 C21/28	289 7 100 C21/28,8	
	1 000	25	—	—	—	—	—	—	—	17,3 406 C21/24,5	26,3 630 C21/25,1	34 844 C21/26	49,6 1 280 C21/26	72 1 800 C21/26,3	99 2 570 C21/27,2	141 3 550 C21/26,4	188 4 500 C21/25,1	234 5 600 C21/25,1	286 7 100 C21/26	
	1 000	25	0,63 14,5 CI/24,1	1,07 25,6 CI/25	1,35 32,3 CI/25	2,33 58 CI/26	2,67 66 CI/26	4,79 110 CI/24,1	10,1 242 CI/25	—	20,6 484 CI/24,6	—	41,2 968 CI/24,6	—	82 1 990 CI/25,4	—	—	—	—	—
	900	22,4	—	—	—	—	—	—	—	16,8 425 C21/23,8	25 630 C21/23,8	35,9 900 C21/23,7	54 1 280 C21/22,4	74 1 800 C21/23	103 2 570 C21/23,6	141 3 550 C21/23,8	184 4 500 C21/23	229 5 600 C21/23	283 7 100 C21/23,7	
	800	20	—	—	—	—	—	—	—	15,5 377 C21/20,4	25,6 630 C21/20,6	33,5 855 C21/21,4	52 1 280 C21/20,5	68 1 610 C21/19,9	100 2 570 C21/21,5	133 3 310 C21/20,8	183 4 500 C21/20,6	228 5 600 C21/20,6	266 6 790 C21/21,4	

Bei  $n_1$  größer als 1 400 min<sup>-1</sup> oder kleiner als 560 min<sup>-1</sup> s. Kap. 6 und Tabelle auf Seite 54.

For  $n_1$  higher than 1 400 min<sup>-1</sup> or lower than 560 min<sup>-1</sup>, see ch. 6 and table on page 54.

9 - Nennleistungen und Nenndrehmomente (Kegelstirnradgetriebe)  
 9 - Nominal powers and torques (right angle shafts)

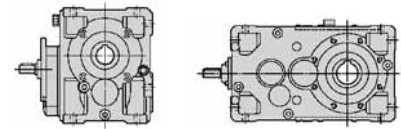

			Getriebegröße - Gear reducer size																	
$n_{N2}$	$n_1$	$i_N$	$P_{N2}$ kW $M_{N2}$ daN m ... //																	
			50	63	64	80	81	100	125	140	160	180	200	225	250	280	320	321	360	
40	800	20	0,63 14,5 CI/19,3	1,14 27,1 CI/20	1,4 33,4 CI/20	2,33 58 CI/20,8	2,69 67 CI/20,8	5,3 121 CI/19,3	10,1 242 CI/20	14,8 353 CI/20	22,4 527 CI/19,7	29,5 714 CI/20,3	46,1 1 080 CI/19,7	59 1 420 CI/20,3	89 2 170 CI/20,3	118 2 810 CI/20	150 3 530 CI/19,7	180 4 230 CI/19,7	228 5 510 CI/20,3	
	710	18	—	—	—	—	—	—	—	14,1 342 CI/18	23,5 569 CI/18	28,2 709 CI/18,7	46,9 1 140 CI/18,7	56 1 400 CI/17,9	94 2 260 CI/17,9	112 2 710 CI/18	143 3 460 CI/18	181 4 380 CI/18	222 5 500 CI/18,4	
	630	16	0,63 14,5 CI/15,2	1,13 27,1 CI/15,8	1,4 33,4 CI/15,8	2,33 58 CI/16,4	2,69 67 CI/16,4	5,3 121 CI/15,2	10,1 242 CI/15,8	14,8 353 CI/15,8	22,4 527 CI/15,5	30,8 746 CI/16	46,1 1 080 CI/15,5	61 1 490 CI/16	89 2 170 CI/16	125 2 980 CI/15,8	147 3 620 CI/16,3	183 4 500 CI/16,3	231 5 610 CI/16	
	560	14	—	—	—	—	—	—	—	15,8 382 CI/14,2	24 580 CI/14,2	31,6 793 CI/14,7	48,8 1 180 CI/14,7	62 1 560 CI/14,7	98 2 360 CI/14,1	125 3 010 CI/14,2	161 3 910 CI/14,2	191 4 620 CI/14,2	246 6 090 CI/14,5	
35,5	1 400	40	—	—	—	—	—	—	—	15,5 409 C21/38,7	23,4 630 C21/39,5	30,4 850 C21/41	44,1 1 280 C21/42,6	64 1 800 C21/41,4	88 2 570 C21/42,8	125 3 550 C21/41,6	167 4 500 C21/39,5	208 5 600 C21/39,5	254 7 100 C21/41	
	1 400	40	0,63 16,5 ICI/38,6	1,15 31,5 ICI/40,1	1,41 38,7 ICI/40,1	2,35 67 ICI/41,8	2,72 78 ICI/41,8	5,2 140 ICI/39,4	10,4 280 ICI/39,4	11,9 325 ICI/40,2	21,8 615 ICI/41,4	25,4 720 ICI/41,6	44,3 1 250 ICI/41,4	—	—	—	—	—	—	—
	1 250	35,5	—	—	—	—	—	—	—	14,8 425 C21/37,5	22 630 C21/37,5	31,6 900 C21/37,3	47,5 1 280 C21/35,3	64 1 780 C21/36,2	90 2 570 C21/37,2	124 3 550 C21/37,5	162 4 500 C21/36,3	202 5 600 C21/36,3	249 7 100 C21/37,3	
	1 120	31,5	—	—	—	—	—	—	—	15,1 412 C21/32	21,8 615 C21/33,1	30,9 875 C21/33,2	42,9 1 250 C21/34,2	61 1 750 C21/33,7	89 2 500 C21/33,1	120 3 450 C21/33,7	168 4 500 C21/31,3	210 5 600 C21/31,3	256 7 100 C21/32,5	
	1 120	31,5	0,58 16 ICI/32,1	0,97 27,4 ICI/33	1,15 32,2 ICI/33	2,29 61 ICI/31,4	2,5 67 ICI/31,4	4,58 128 ICI/32,8	9,3 257 ICI/32,4	—	20,7 553 ICI/31,4	—	40,8 1 140 ICI/32,7	—	—	—	—	—	—	—
	1 120	31,5	—	0,79 21 CI/31,3	0,93 24,7 CI/31,3	1,58 43,7 CI/32,5	1,91 53 CI/32,5	3,52 90 CI/30,1	6,7 178 CI/31,3	—	13,3 350 CI/30,8	—	26,3 691 CI/30,8	—	53 1 420 CI/31,7	—	—	—	—	—
	1 000	28	—	—	—	—	—	—	—	15,6 425 C21/28,6	22,8 630 C21/28,9	32,7 900 C21/28,8	45,4 1 280 C21/29,5	62 1 800 C21/30,3	90 2 570 C21/29,9	123 3 550 C21/30,1	168 4 500 C21/28	209 5 600 C21/28	258 7 100 C21/28,8	
	900	25	—	—	—	—	—	—	—	15,7 408 C21/24,5	23,7 630 C21/25,1	30,8 849 C21/26	44,7 1 280 C21/27	65 1 800 C21/26,3	89 2 570 C21/27,2	127 3 550 C21/26,4	169 4 500 C21/25,1	211 5 600 C21/25,1	257 7 100 C21/26	
	900	25	0,57 14,5 CI/24,1	0,97 25,7 CI/25	1,22 32,5 CI/25	2,1 58 CI/26	2,41 67 CI/26	4,33 111 CI/24,1	9,2 243 CI/25	—	18,7 488 CI/24,6	—	37,4 977 CI/24,6	—	74 2 010 CI/25,4	—	—	—	—	—
	800	22,4	—	—	—	—	—	—	—	15 425 C21/23,8	22,2 630 C21/23,8	31,9 900 C21/23,7	47,9 1 280 C21/22,4	66 1 800 C21/23	91 2 570 C21/23,6	125 3 550 C21/23,8	164 4 500 C21/23	204 5 600 C21/23	251 7 100 C21/23,7	
	710	20	—	—	—	—	—	—	—	13,8 380 C21/20,4	22,7 630 C21/20,6	29,9 860 C21/21,4	46,5 1 280 C21/20,5	61 1 620 C21/19,9	89 2 570 C21/21,5	119 3 350 C21/20,8	162 4 500 C21/20,6	202 5 600 C21/20,6	239 6 860 C21/21,4	
	710	20	0,56 14,5 CI/19,3	1,01 27,2 CI/20	1,25 33,5 CI/20	2,07 58 CI/20,8	2,39 67 CI/20,8	4,71 122 CI/19,3	9 243 CI/20	13,2 355 CI/20	20 530 CI/19,7	26,5 723 CI/20,3	41,2 1 090 CI/19,7	53 1 440 CI/20,3	80 2 180 CI/20,3	106 2 840 CI/20	134 3 550 CI/19,7	160 4 250 CI/19,7	204 5 560 CI/20,3	
	630	18	—	—	—	—	—	—	—	12,5 342 CI/18	21 574 CI/18	25,1 709 CI/18,7	42 1 150 CI/18	49,6 1 400 CI/18,7	84 2 280 CI/17,9	99 2 710 CI/18	128 3 500 CI/18	162 4 420 CI/18	197 5 500 CI/18,4	
	560	16	0,56 14,5 CI/15,2	1,01 27,2 CI/15,8	1,25 33,5 CI/15,8	2,07 58 CI/16,4	2,4 67 CI/16,4	4,71 122 CI/15,2	9 243 CI/15,8	13,2 355 CI/15,8	20 530 CI/15,5	27,5 750 CI/16	41,2 1 090 CI/15,5	55 1 500 CI/16	80 2 180 CI/16	112 3 000 CI/15,8	132 3 650 CI/16,3	164 4 540 CI/16,3	207 5 640 CI/16	
	31,5	1 400	45	—	—	—	—	—	—	13,8 425 C21/45,1	20,2 630 C21/45,6	29,1 900 C21/45,4	40,3 1 280 C21/46,6	55 1 800 C21/47,8	80 2 570 C21/47,1	110 3 550 C21/47,5	149 4 500 C21/44,2	186 5 600 C21/44,2	229 7 100 C21/45,4	
		1 250	40	—	—	—	—	—	—	13,9 411 C21/38,7	20,9 630 C21/39,5	27,3 855 C21/41	39,3 1 280 C21/42,6	57 1 800 C21/41,4	79 2 570 C21/42,8	112 3 550 C21/41,6	149 4 500 C21/39,5	185 5 600 C21/39,5	227 7 100 C21/41	
1 250		40	0,56 16,5 ICI/38,6	1,03 31,5 ICI/40,1	1,26 38,7 ICI/40,1	2,1 67 ICI/41,8	2,43 78 ICI/41,8	4,65 140 ICI/39,4	9,3 280 ICI/39,4	10,6 325 ICI/40,2	19,5 615 ICI/41,4	22,9 727 ICI/41,6	39,5 1 250 ICI/41,4	—	—	—	—	—	—	
1 120		35,5	—	—	—	—	—	—	—	13,3 425 C21/37,5	19,7 630 C21/37,5	28,3 900 C21/37,3	42,5 1 280 C21/35,3	58 1 800 C21/36,2	81 2 570 C21/37,2	111 3 550 C21/37,5	146 4 500 C21/36,3	181 5 600 C21/36,3	223 7 100 C21/37,3	
1 000		31,5	—	—	—	—	—	—	—	13,5 412 C21/32	19,5 615 C21/33,1	27,6 875 C21/33,2	38,3 1 250 C21/34,2	54 1 750 C21/33,7	79 2 500 C21/33,1	107 3 450 C21/31,3	150 4 500 C21/31,3	187 5 600 C21/31,3	229 7 100 C21/32,5	

Bei  $n_1$  größer als 1 400 min<sup>-1</sup> oder kleiner als 560 min<sup>-1</sup> s. Kap. 6 und Tabelle auf Seite 54.

For  $n_1$  higher than 1 400 min<sup>-1</sup> or lower than 560 min<sup>-1</sup>, see ch. 6 and table on page 54.

9 - Nennleistungen und Nenndrehmomente (Kegelstirnradgetriebe)  
9 - Nominal powers and torques (right angle shafts)

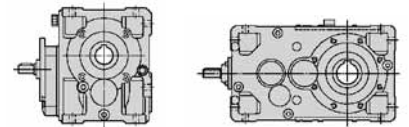

		Getriebegröße - Gear reducer size																		
		$P_{N2}$ kW $M_{N2}$ daN m ... / i																		
$n_{N2}$	$n_1$	$i_N$	50	63	64	80	81	100	125	140	160	180	200	225	250	280	320	321	360	
min <sup>-1</sup>																				
31,5	1 000	31,5	0,52 16 ICI/32,1	0,87 27,4 ICI/33	1,02 32,2 ICI/33	2,05 61 ICI/31,4	2,23 67 ICI/31,4	4,09 128 ICI/32,8	8,3 257 ICI/32,4	—	18,5 553 ICI/31,4	—	36,4 1 140 ICI/32,7	—	—	—	—	—	—	
	1 000	31,5	—	0,71 21,1 CI/31,3	0,83 24,9 CI/31,3	1,42 43,9 CI/32,5	1,72 53 CI/32,5	3,16 91 CI/30,1	6 179 CI/31,3	—	12 353 CI/30,8	—	23,8 699 CI/30,8	—	47,4 1 440 CI/31,7	—	—	—	—	
	900	28	—	—	—	—	—	—	—	14 425 C21/28,6	20,5 630 C21/28,9	29,5 900 C21/28,8	40,9 1 280 C21/29,5	56 1 800 C21/30,3	81 2 570 C21/29,9	111 3 550 C21/30,1	151 4 500 C21/28	188 5 600 C21/28	232 7 100 C21/28,8	
	800	25	—	—	—	—	—	—	—	14 411 C21/24,5	21,1 630 C21/25,1	27,5 855 C21/26	39,7 1 280 C21/27	57 1 800 C21/26,3	79 2 570 C21/27,2	113 3 550 C21/26,4	150 4 500 C21/25,1	187 5 600 C21/25,1	229 7 100 C21/26	
	800	25	0,5 14,5 CI/24,1	0,87 25,8 CI/25	1,09 32,6 CI/25	1,87 58 CI/26	2,16 67 CI/26	3,86 111 CI/24,1	8,1 243 CI/25	—	16,8 493 CI/24,6	—	33,6 986 CI/24,6	—	67 2 030 CI/25,4	—	—	—	—	—
	710	22,4	—	—	—	—	—	—	—	13,3 425 C21/23,8	19,7 630 C21/23,8	28,3 900 C21/23,7	42,5 1 280 C21/22,4	58 1 800 C21/23	81 2 570 C21/23,6	111 3 550 C21/23,8	145 4 500 C21/23	181 5 600 C21/23	223 7 100 C21/23,7	
	630	20	—	—	—	—	—	—	—	12,3 382 C21/20,4	20,2 630 C21/20,6	26,7 866 C21/21,4	41,2 1 280 C21/20,5	54 1 640 C21/19,9	79 2 570 C21/21,5	107 3 380 C21/20,8	144 4 500 C21/20,6	179 5 600 C21/20,6	214 6 940 C21/21,4	
	630	20	0,496 14,5 CI/19,3	0,9 27,2 CI/20	1,1 33,5 CI/20	1,84 58 CI/20,8	2,12 67 CI/20,8	4,18 122 CI/19,3	8 243 CI/20	11,7 355 CI/20	17,8 530 CI/19,7	23,8 731 CI/20,3	36,5 1 090 CI/19,7	47,3 1 450 CI/20,3	71 2 180 CI/20,3	95 2 870 CI/20	120 3 570 CI/19,7	143 4 270 CI/19,7	183 5 620 CI/20,3	
	560	18	—	—	—	—	—	—	—	11,1 342 CI/18	18,9 579 CI/18	22,3 709 CI/18,7	37,7 1 160 CI/18	44,1 1 400 CI/18,7	76 2 300 CI/17,9	88 2 710 CI/18	115 3 530 CI/18	145 4 460 CI/18	175 5 500 CI/18,4	
	28	1 400	50	—	—	—	—	—	—	—	12 412 C21/50,4	17,3 615 C21/52,1	24,5 875 C21/52,4	34 1 250 C21/53,9	48,3 1 750 C21/53,1	70 2 500 C21/52,1	95 3 450 C21/53,1	125 4 370 C21/51,3	151 5 300 C21/51,3	200 6 900 C21/50,5
1 400		50	0,494 16,5 ICI/49	0,82 28,4 ICI/50,9	0,98 34 ICI/50,9	1,73 63 ICI/53	1,96 71 ICI/53	3,86 131 ICI/49,9	8,2 280 ICI/50	10,6 355 ICI/49,3	17,2 615 ICI/52,5	21,7 750 ICI/50,8	34,1 1 220 ICI/52,5	—	—	—	—	—	—	
1 250		45	—	—	—	—	—	—	—	12,3 425 C21/45,1	18,1 630 C21/45,6	25,9 900 C21/45,4	36 1 280 C21/46,6	49,3 1 800 C21/47,8	71 2 570 C21/47,1	98 3 550 C21/47,5	133 4 500 C21/44,2	166 5 600 C21/44,2	205 7 100 C21/45,4	
1 120		40	—	—	—	—	—	—	—	12,5 414 C21/38,7	18,7 630 C21/39,5	24,6 860 C21/41	35,3 1 280 C21/42,6	51 1 800 C21/41,4	70 2 570 C21/42,8	100 3 550 C21/41,6	134 4 500 C21/39,5	166 5 600 C21/39,5	203 7 100 C21/41	
1 120		40	0,5 16,5 ICI/38,6	0,92 31,5 ICI/40,1	1,13 38,7 ICI/40,1	1,88 67 ICI/41,8	2,17 78 ICI/41,8	4,17 140 ICI/39,4	8,3 280 ICI/39,4	9,5 325 ICI/40,2	17,4 615 ICI/41,4	20,7 733 ICI/41,6	35,4 1 250 ICI/41,4	—	—	—	—	—	—	
1 000		35,5	—	—	—	—	—	—	—	11,9 425 C21/37,5	17,6 630 C21/37,5	25,3 900 C21/37,3	38 1 280 C21/35,3	52 1 800 C21/36,2	72 2 570 C21/37,2	99 3 550 C21/37,5	130 4 500 C21/36,3	162 5 600 C21/36,3	199 7 100 C21/37,3	
900		31,5	—	—	—	—	—	—	—	12,1 412 C21/32	17,5 615 C21/33,1	24,8 875 C21/33,2	34,5 1 250 C21/34,2	49 1 750 C21/33,7	71 2 500 C21/33,1	96 3 450 C21/33,7	135 4 500 C21/31,3	168 5 600 C21/31,3	206 7 100 C21/32,5	
900		31,5	0,469 16 ICI/32,1	0,78 27,4 ICI/33	0,92 32,2 ICI/33	1,84 61 ICI/31,4	2,01 67 ICI/31,4	3,68 128 ICI/32,8	7,5 257 ICI/32,4	—	16,6 553 ICI/31,4	—	32,8 1 140 ICI/32,7	—	—	—	—	—	—	
900		31,5	—	0,64 21,2 CI/31,3	0,75 25 CI/31,3	1,28 44,1 CI/32,5	1,43 49,2 CI/32,5	2,86 91 CI/30,1	5,5 181 CI/31,3	—	10,9 357 CI/30,8	—	21,6 707 CI/30,8	—	43 1 450 CI/31,7	—	—	—	—	
800		28	—	—	—	—	—	—	—	12,5 425 C21/28,6	18,2 630 C21/28,9	26,2 900 C21/28,8	36,3 1 280 C21/29,5	49,7 1 800 C21/30,3	72 2 570 C21/29,9	99 3 550 C21/30,1	135 4 500 C21/28	168 5 600 C21/28	207 7 100 C21/28,8	
710		25	—	—	—	—	—	—	—	12,5 414 C21/24,5	18,7 630 C21/25,1	24,6 860 C21/26	35,2 1 280 C21/27	51 1 800 C21/26,3	70 2 570 C21/27,2	100 3 550 C21/26,4	133 4 500 C21/25,1	166 5 600 C21/25,1	203 7 100 C21/26	
710		25	0,447 14,5 CI/24,1	0,77 26 CI/25	0,98 32,8 CI/25	1,66 58 CI/26	1,92 67 CI/26	3,45 112 CI/24,1	7,2 243 CI/25	—	15 498 CI/24,6	—	30,1 996 CI/24,6	—	60 2 050 CI/25,4	—	—	—	—	
630		22,4	—	—	—	—	—	—	—	11,8 425 C21/23,8	17,5 630 C21/23,8	25,1 900 C21/23,7	37,7 1 280 C21/22,4	48,8 1 800 C21/23	70 2 570 C21/23,6	98 3 550 C21/23,8	129 4 500 C21/23	161 5 600 C21/23	198 7 100 C21/23,7	
560	20	—	—	—	—	—	—	—	11 384 C21/20,4	17,9 630 C21/20,6	23,9 871 C21/21,4	36,7 1 280 C21/20,5	48,8 1 660 C21/19,9	70 2 570 C21/21,5	96 3 420 C21/20,8	128 4 500 C21/20,6	159 5 600 C21/20,6	192 7 010 C21/21,4		

Bei  $n_1$  größer als 1 400 min<sup>-1</sup> oder kleiner als 560 min<sup>-1</sup> s. Kap. 6 und Tabelle auf Seite 54.

For  $n_1$  higher than 1 400 min<sup>-1</sup> or lower than 560 min<sup>-1</sup>, see ch. 6 and table on page 54.

9 - Nennleistungen und Nenndrehmomente (Kegelstirradgetriebe)  
9 - Nominal powers and torques (right angle shafts)

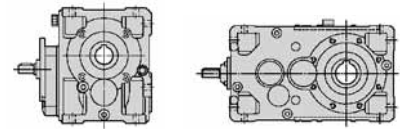

$n_{N2}$ min <sup>-1</sup>	$n_1$ min <sup>-1</sup>	$i_N$	Getriebegröße - Gear reducer size																	
			$P_{N2}$ kW $M_{N2}$ daNm ... / i																	
			50	63	64	80	81	100	125	140	160	180	200	225	250	280	320	321	360	
28	560	20	0,441 14,5 CI/19,3	0,8 27,2 CI/20	0,98 33,5 CI/20	1,64 58 CI/20,8	1,89 67 CI/20,8	3,71 122 CI/19,3	7,1 243 CI/20	10,4 355 CI/20	15,8 530 CI/19,7	21,4 739 CI/20,3	32,5 1 090 CI/19,6	42,4 1 470 CI/20,3	63 2 180 CI/20,3	85 2 900 CI/20	107 3 590 CI/19,7	128 4 290 CI/19,7	164 5 670 CI/20,3	
25	1 400	56	—	—	—	—	—	—	—	11,3 425 C21/55,4	16,2 630 C21/57	21,1 818 C21/56,8	33,8 1 280 C21/55,5	46,3 1 800 C21/56,9	67 2 570 C21/56,1	92 3 550 C21/56,6	118 4 500 C21/56	146 5 600 C21/56	181 7 100 C21/57,6	
	1 250	50	—	—	—	—	—	—	—	10,7 412 C21/50,4	15,4 615 C21/52,1	21,9 875 C21/52,4	30,4 1 250 C21/53,9	43,2 1 750 C21/53,1	63 2 500 C21/52,1	85 3 450 C21/53,1	111 4 370 C21/51,3	135 5 300 C21/51,3	179 6 900 C21/50,5	
	1 250	50	0,441 16,5 ICI/49	0,73 28,5 ICI/50,9	0,88 34,2 ICI/50,9	1,55 63 ICI/53	1,76 71 ICI/53	3,46 132 ICI/49,9	7,3 280 ICI/50	9,4 355 ICI/49,3	15,3 615 ICI/52,5	19,3 750 ICI/50,8	30,8 1 230 ICI/52,5	—	—	—	—	—	—	—
	1 120	45	—	—	—	—	—	—	—	11,1 425 C21/45,1	16,2 630 C21/45,6	23,2 900 C21/45,4	32,2 1 280 C21/46,6	44,2 1 800 C21/47,8	64 2 570 C21/47,1	88 3 550 C21/47,5	120 4 500 C21/44,2	149 5 600 C21/44,2	183 7 100 C21/45,4	
	1 000	40	—	—	—	—	—	—	—	11,3 416 C21/38,7	16,7 630 C21/39,5	22,1 865 C21/41	31,5 1 280 C21/42,6	45,5 1 800 C21/41,4	63 2 570 C21/42,8	89 3 550 C21/41,6	119 4 500 C21/39,5	148 5 600 C21/39,5	181 7 100 C21/41	
	1 000	40	0,448 16,5 ICI/38,6	0,82 31,5 ICI/40,1	1,01 38,7 ICI/40,1	1,68 67 ICI/41,8	1,94 78 ICI/41,8	3,72 140 ICI/39,4	7,4 280 ICI/39,4	8,5 325 ICI/40,2	15,6 615 ICI/41,4	18,5 733 ICI/41,6	31,6 1 250 ICI/41,4	—	—	—	—	—	—	—
	900	35,5	—	—	—	—	—	—	—	10,7 425 C21/37,5	15,8 630 C21/37,5	22,7 900 C21/37,3	34,2 1 280 C21/35,3	46,8 1 800 C21/36,2	65 2 570 C21/37,2	89 3 550 C21/37,5	117 4 500 C21/36,3	146 5 600 C21/36,3	179 7 100 C21/37,3	
	800	31,5	—	—	—	—	—	—	—	10,8 412 C21/32	15,6 615 C21/33,1	22,1 875 C21/33,2	30,6 1 250 C21/34,2	43,6 1 750 C21/33,7	63 2 500 C21/33,1	86 3 450 C21/33,7	120 4 500 C21/31,3	150 5 600 C21/31,3	183 7 100 C21/32,5	
	800	31,5	0,417 16 ICI/32,1	0,7 27,4 ICI/33	0,82 32,2 ICI/33	1,64 61 ICI/31,4	1,78 67 ICI/31,4	3,27 128 ICI/32,8	6,6 257 ICI/32,4	—	14,8 553 ICI/31,4	—	29,1 1 140 ICI/32,7	—	—	—	—	—	—	—
	800	31,5	—	0,57 21,3 CI/31,3	0,67 25,1 CI/31,3	1,14 44,4 CI/32,5	1,39 54 CI/32,5	2,55 92 CI/30,1	4,9 183 CI/31,3	—	9,8 360 CI/30,8	—	19,5 715 CI/30,8	—	38,7 1 460 CI/31,7	—	—	—	—	—
	710	28	—	—	—	—	—	—	—	11,1 425 C21/28,6	16,2 630 C21/28,9	23,2 900 C21/28,8	32,2 1 280 C21/29,5	44,1 1 800 C21/30,3	64 2 570 C21/29,9	88 3 550 C21/30,1	119 4 500 C21/28	149 5 600 C21/28	183 7 100 C21/28,8	
	630	25	—	—	—	—	—	—	—	11,2 416 C21/24,5	16,6 630 C21/25,1	22 866 C21/26	31,3 1 280 C21/27	45,2 1 800 C21/26,3	62 2 570 C21/27,2	89 3 550 C21/26,4	118 4 500 C21/25,1	147 5 600 C21/25,1	180 7 100 C21/26	
	630	25	0,397 14,5 CI/24,1	0,69 26,1 CI/25	0,87 33 CI/25	1,47 58 CI/26	1,7 67 CI/26	3,07 112 CI/24,1	6,4 243 CI/25	—	13,5 503 CI/24,6	—	26,9 1 010 CI/24,6	—	54 2 070 CI/25,4	—	—	—	—	—
	560	22,4	—	—	—	—	—	—	—	10,5 425 C21/23,8	15,5 630 C21/23,8	22,3 900 C21/23,7	33,5 1 280 C21/22,4	45,9 1 800 C21/23	64 2 570 C21/23,6	87 3 550 C21/23,8	115 4 500 C21/23	143 5 600 C21/23	176 7 100 C21/23,7	
	22,4	1 400	63	—	—	—	—	—	—	—	9,7 412 C21/62	13,8 615 C21/65,2	19,6 875 C21/65,5	28,6 1 250 C21/64,2	40,6 1 750 C21/63,2	59 2 500 C21/62,1	80 3 450 C21/63,3	98 4 370 C21/65,1	119 5 300 C21/65,1	158 6 900 C21/64
1 400		63	0,354 14,5 ICI/60,1	0,63 27,2 ICI/63,6	0,77 33,5 ICI/63,6	1,28 58 ICI/66,2	1,48 67 ICI/66,2	2,92 122 ICI/61,3	5,7 243 ICI/62,5	8,3 355 ICI/62,5	12,4 530 ICI/62,5	17,1 750 ICI/64,4	25,6 1 090 ICI/62,5	—	—	—	—	—	—	
1 250		56	—	—	—	—	—	—	—	10 425 C21/55,4	14,5 630 C21/57	19 823 C21/56,8	30,2 1 280 C21/55,5	41,4 1 800 C21/56,9	60 2 570 C21/56,1	82 3 550 C21/56,6	105 4 500 C21/56	131 5 600 C21/56	161 7 100 C21/57,6	
1 120		50	—	—	—	—	—	—	—	9,6 412 C21/50,4	13,8 615 C21/52,1	19,6 875 C21/52,4	27,2 1 250 C21/53,9	38,7 1 750 C21/53,1	56 2 500 C21/52,1	76 3 450 C21/53,1	100 4 370 C21/51,3	121 5 300 C21/51,3	160 6 900 C21/50,5	
1 120		50	0,395 16,5 ICI/49	0,66 28,6 ICI/50,9	0,79 34,3 ICI/50,9	1,4 63 ICI/53	1,58 71 ICI/53	3,12 133 ICI/49,9	6,6 280 ICI/50	8,4 355 ICI/49,3	13,7 615 ICI/52,5	17,3 750 ICI/50,8	27,8 1 240 ICI/52,5	—	—	—	—	—	—	
1 000		45	—	—	—	—	—	—	—	9,9 425 C21/45,1	14,5 630 C21/45,6	20,8 900 C21/45,4	28,8 1 280 C21/46,6	39,4 1 800 C21/47,8	57 2 570 C21/47,1	78 3 550 C21/47,5	107 4 500 C21/44,2	133 5 600 C21/44,2	164 7 100 C21/45,4	
900		40	—	—	—	—	—	—	—	10,2 418 C21/38,7	15 630 C21/39,5	20 870 C21/41	28,3 1 280 C21/42,6	41 1 800 C21/41,4	57 2 570 C21/42,8	81 3 550 C21/41,6	107 4 500 C21/39,5	134 5 600 C21/39,5	163 7 100 C21/41	
900		40	0,403 16,5 ICI/38,6	0,74 31,5 ICI/40,1	0,91 38,7 ICI/40,1	1,51 67 ICI/41,8	1,75 78 ICI/41,8	3,35 140 ICI/39,4	6,7 280 ICI/39,4	7,6 325 ICI/40,2	14 615 ICI/41,4	16,6 733 ICI/41,6	28,5 1 250 ICI/41,4	—	—	—	—	—	—	

Bei  $n_1$  größer als 1 400 min<sup>-1</sup> oder kleiner als 560 min<sup>-1</sup> s. Kap. 6 und Tabelle auf Seite 54.

For  $n_1$  higher than 1 400 min<sup>-1</sup> or lower than 560 min<sup>-1</sup>, see ch. 6 and table on page 54.



9 - Nennleistungen und Nenndrehmomente (Kegelstirnradgetriebe)  
 9 - Nominal powers and torques (right angle shafts)

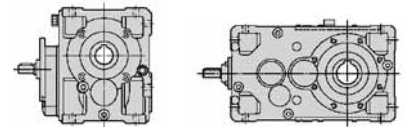

$n_{N2}$   $n_1$		$i_N$	Getriebegröße - Gear reducer size																	
			50	63	64	80	81	100	125	140	160	180	200	225	250	280	320	321	360	
$\text{min}^{-1}$			$P_{N2}$ kW $M_{N2}$ daNm ... / i																	
22,4	800	35,5	—	—	—	—	—	—	—	9,5 425 C21/37,5	14,1 630 C21/37,5	20,2 900 C21/37,3	30,4 1 280 C21/35,3	41,6 1 800 C21/36,2	58 2 570 C21/37,2	79 3 550 C21/37,5	104 4 500 C21/36,3	129 5 600 C21/36,3	159 7 100 C21/37,3	
	710	31,5	—	—	—	—	—	—	—	9,6 412 C21/32	13,8 615 C21/33,1	19,6 875 C21/33,2	27,2 1 250 C21/34,2	38,7 1 750 C21/33,7	56 2 500 C21/33,1	76 3 450 C21/33,7	107 4 500 C21/31,3	133 5 600 C21/31,3	162 7 100 C21/32,5	
	710	31,5	0,37 16 ICI/32,1	0,62 27,4 ICI/33	0,73 32,2 ICI/33	1,45 61 ICI/31,4	1,58 67 ICI/31,4	2,9 128 ICI/32,8	5,9 257 ICI/32,4	—	553 ICI/31,4	13,1 —	25,8 1 140 ICI/32,7	—	—	—	—	—	—	—
	710	31,5	—	0,51 21,4 CI/31,3	0,6 25,2 CI/31,3	1,02 44,6 CI/32,5	1,24 54 CI/32,5	2,27 92 CI/30,1	4,4 185 CI/31,3	—	8,8 364 CI/30,8	—	17,5 723 CI/30,8	—	34,7 1 480 CI/31,7	—	—	—	—	—
	630	28	—	—	—	—	—	—	—	9,8 425 C21/28,6	14,4 630 C21/28,9	20,6 900 C21/29,5	28,6 1 280 C21/29,5	39,2 1 800 C21/30,3	57 2 570 C21/30,1	78 3 550 C21/28	106 4 500 C21/28	132 5 600 C21/28	163 7 100 C21/28,8	
	560	25	—	—	—	—	—	—	—	10 419 C21/24,5	14,7 630 C21/25,1	19,6 871 C21/26	27,8 1 280 C21/27	40,2 1 800 C21/26,3	55 2 570 C21/27,2	79 3 550 C21/26,4	105 4 500 C21/25,1	131 5 600 C21/25,1	160 7 100 C21/26	
	560	25	0,353 14,5 CI/24,1	0,61 26,2 CI/25	0,78 33,2 CI/25	1,31 58 CI/26	1,51 67 CI/26	2,74 113 CI/24,1	5,7 243 CI/25	—	12,1 507 CI/24,6	—	24,2 1 020 CI/24,6	—	48,3 2 090 CI/25,4	—	—	—	—	—
	20	1 400	71	—	—	—	—	—	—	—	8,9 425 C21/70,2	12,8 630 C21/72,3	16,9 829 C21/72	26,7 1 280 C21/70,3	36,5 1 800 C21/72,2	53 2 570 C21/71,2	73 3 550 C21/71,1	93 4 500 C21/71,1	116 5 600 C21/71,1	142 7 100 C21/73,1
1 250		63	—	—	—	—	—	—	—	8,7 412 C21/62	12,4 615 C21/65,2	17,5 875 C21/65,5	25,5 1 250 C21/64,2	36,2 1 750 C21/63,2	53 2 500 C21/62,1	88 3 450 C21/63,3	107 4 370 C21/65,1	141 5 300 C21/65,1	190 6 900 C21/64	
1 250		63	0,316 14,5 ICI/60,1	0,56 27,2 ICI/63,6	0,69 33,5 ICI/63,6	1,15 58 ICI/66,2	1,33 67 ICI/66,2	2,6 122 ICI/61,3	5,1 243 ICI/62,5	7,4 355 ICI/62,5	11,1 530 ICI/62,5	15,2 750 ICI/64,4	22,8 1 090 ICI/62,5	—	—	—	—	—	—	—
1 120		56	—	—	—	—	—	—	—	9 425 C21/55,4	13 630 C21/57	17,1 828 C21/56,8	27,1 1 280 C21/55,5	37,1 1 800 C21/56,9	54 2 570 C21/56,1	74 3 550 C21/56,6	94 4 500 C21/56	117 5 600 C21/56	144 7 100 C21/57,6	
1 000		50	—	—	—	—	—	—	—	412 C21/50,4	615 C21/52,1	875 C21/52,4	1 250 C21/53,9	1 750 C21/53,1	2 500 C21/52,1	3 450 C21/53,1	4 370 C21/51,3	5 300 C21/51,3	6 900 C21/50,5	
1 000		50	0,353 16,5 ICI/49	0,59 28,6 ICI/50,9	0,71 34,3 ICI/50,9	1,25 63 ICI/53	1,41 71 ICI/53	2,78 133 ICI/49,9	5,9 280 ICI/50	7,5 355 ICI/49,3	12,3 615 ICI/52,5	15,5 750 ICI/50,8	24,8 1 240 ICI/52,5	—	—	—	—	—	—	—
900		45	—	—	—	—	—	—	—	8,9 425 C21/45,1	13 630 C21/45,6	18,7 900 C21/45,4	25,9 1 280 C21/46,6	35,5 1 800 C21/47,8	51 2 570 C21/47,1	70 3 550 C21/47,5	96 4 500 C21/44,2	120 5 600 C21/44,2	147 7 100 C21/45,4	
800		40	—	—	—	—	—	—	—	9,1 421 C21/38,7	13,4 630 C21/39,5	17,9 876 C21/41	25,2 1 280 C21/42,6	36,4 1 800 C21/41,4	50 2 570 C21/42,8	72 3 550 C21/41,6	89 4 500 C21/39,5	108 5 600 C21/39,5	143 7 100 C21/41	
800		40	0,358 16,5 ICI/38,6	0,66 31,5 ICI/40,1	0,81 38,7 ICI/40,1	1,34 67 ICI/41,8	1,55 78 ICI/41,8	2,98 140 ICI/39,4	5,9 280 ICI/39,4	5,9 325 ICI/40,2	8,8 615 ICI/41,4	12,5 733 ICI/41,6	17,9 1 250 ICI/41,4	27 1 250 ICI/41,4	36,9 1 800 C21/36,2	51 2 570 C21/37,2	70 3 550 C21/36,3	92 4 500 C21/36,3	115 5 600 C21/37,3	141 7 100 C21/37,3
710		35,5	—	—	—	—	—	—	—	8,4 425 C21/37,5	12,5 630 C21/37,5	17,9 900 C21/37,3	27 1 280 C21/35,3	36,9 1 800 C21/36,2	51 2 570 C21/37,2	70 3 550 C21/37,5	92 4 500 C21/36,3	115 5 600 C21/36,3	141 7 100 C21/37,3	
630		31,5	—	—	—	—	—	—	—	8,5 412 C21/32	12,3 615 C21/33,1	17,4 875 C21/33,2	24,1 1 250 C21/34,2	34,3 1 750 C21/33,7	49,9 2 500 C21/33,1	68 3 450 C21/33,7	95 4 500 C21/31,3	118 5 600 C21/31,3	144 7 100 C21/32,5	
630		31,5	0,329 16 ICI/32,1	0,55 27,4 ICI/33	0,64 32,2 ICI/33	1,29 61 ICI/31,4	1,4 67 ICI/31,4	2,58 128 ICI/32,8	5,2 257 ICI/32,4	—	11,6 553 ICI/31,4	—	22,9 1 140 ICI/32,7	—	—	—	—	—	—	—
630		31,5	—	0,455 21,5 CI/31,3	0,54 25,4 CI/31,3	0,91 44,8 CI/32,5	1,1 54 CI/32,5	2,03 92 CI/30,1	3,94 187 CI/31,3	—	7,9 368 CI/30,8	—	15,7 732 CI/30,8	—	31,1 1 490 CI/31,7	—	—	—	—	—
560		28	—	—	—	—	—	—	—	8,7 425 C21/28,6	12,8 630 C21/28,9	18,3 900 C21/28,8	25,4 1 280 C21/29,5	34,8 1 800 C21/30,3	50 2 570 C21/29,9	69 3 550 C21/30,1	94 4 500 C21/28	117 5 600 C21/28	145 7 100 C21/28,8	
18		1 400	80	—	—	—	—	—	—	—	7,7 412 C21/78,6	10,9 615 C21/82,7	15,4 875 C21/83,1	22,5 1 250 C21/81,4	32 1 750 C21/80,2	46,5 2 500 C21/78,8	63 3 450 C21/80,3	78 4 370 C21/82,6	94 5 300 C21/82,6	125 6 900 C21/81,2
		1 400	80	0,283 14,5 ICI/75,2	0,5 27,2 ICI/79,5	0,62 33,5 ICI/79,5	1,03 58 ICI/82,7	1,19 67 ICI/82,7	2,33 122 ICI/76,7	4,56 243 ICI/78,1	5,7 301 ICI/78,1	9,9 530 ICI/80,5	11 606 ICI/80,5	20,5 1 090 ICI/78,1	—	—	—	—	—	—

Bei  $n_1$  größer als 1 400  $\text{min}^{-1}$  oder kleiner als 560  $\text{min}^{-1}$  s. Kap. 6 und Tabelle auf Seite 54.

For  $n_1$  higher than 1 400  $\text{min}^{-1}$  or lower than 560  $\text{min}^{-1}$ , see ch. 6 and table on page 54.

9 - Nennleistungen und Nenndrehmomente (Kegelstirradgetriebe)  
 9 - Nominal powers and torques (right angle shafts)

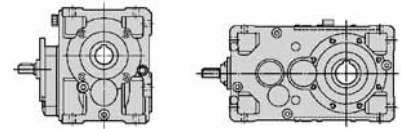

$n_{N2}$	$n_1$	$i_N$	Getriebegröße - Gear reducer size																	
			$P_{N2}$ kW $M_{N2}$ daN m ... / i																	
			50	63	64	80	81	100	125	140	160	180	200	225	250	280	320	321	360	
18	1 250	71	—	—	—	—	—	—	—	7,9 425 C21/70,2	11,4 630 C21/72,3	15,2 834 C21/72	23,8 1 280 C21/70,3	32,6 1 800 C21/72,2	47,2 2 570 C21/71,2	65 3 550 C21/71,7	83 4 500 C21/71,1	103 5 600 C21/71,1	127 7 100 C21/73,1	
	1 120	63	—	—	—	—	—	—	—	7,8 412 C21/62	11,1 615 C21/65,2	15,7 875 C21/65,5	22,8 1 250 C21/64,2	32,5 1 750 C21/63,2	47,2 2 500 C21/62,1	64 3 450 C21/63,3	79 4 370 C21/65,1	95 5 300 C21/65,1	126 6 900 C21/64	
	1 120	63	0,283 14,5 ICI/60,1	0,5 27,2 ICI/63,6	0,62 33,5 ICI/63,6	1,03 58 ICI/66,2	1,19 67 ICI/66,2	2,33 122 ICI/61,3	4,56 243 ICI/62,5	6,7 355 ICI/62,5	9,9 530 ICI/62,5	13,7 750 ICI/64,4	20,5 1 090 ICI/62,5	—	—	—	—	—	—	—
	1 000	56	—	—	—	—	—	—	—	8 425 C21/55,4	11,6 630 C21/57	15,4 833 C21/56,8	24,2 1 280 C21/55,5	33,1 1 800 C21/56,9	47,9 2 570 C21/56,1	66 3 550 C21/56,6	84 4 500 C21/56	105 5 600 C21/56	129 7 100 C21/57,6	
	900	50	—	—	—	—	—	—	—	7,7 412 C21/50,4	11,1 615 C21/52,1	15,7 875 C21/52,4	21,9 1 250 C21/53,9	31,1 1 750 C21/53,1	45,2 2 500 C21/52,1	61 3 450 C21/53,1	80 4 370 C21/51,3	97 5 300 C21/51,3	129 6 900 C21/50,5	
	900	50	0,318 16,5 ICI/49	0,53 28,6 ICI/50,9	0,63 34,3 ICI/50,9	1,12 63 ICI/53	1,27 71 ICI/53	2,5 133 ICI/49,9	5,3 280 ICI/50	6,8 355 ICI/49,3	11 615 ICI/52,5	13,9 750 ICI/50,8	22,3 1 240 ICI/52,5	—	—	—	—	—	—	—
	800	45	—	—	—	—	—	—	—	7,9 425 C21/45,1	11,6 630 C21/45,6	16,6 900 C21/45,4	23 1 280 C21/46,6	31,5 1 800 C21/47,8	45,7 2 570 C21/47,1	63 3 550 C21/47,5	85 4 500 C21/44,2	106 5 600 C21/44,2	131 7 100 C21/45,4	
	710	40	—	—	—	—	—	—	—	8,1 424 C21/38,7	11,8 630 C21/39,5	16 881 C21/41	22,3 1 280 C21/42,6	32,3 1 800 C21/41,4	44,6 2 570 C21/42,8	64 3 550 C21/41,6	85 4 500 C21/39,5	105 5 600 C21/39,5	129 7 100 C21/41	
	710	40	0,318 16,5 ICI/38,6	0,58 31,5 ICI/40,1	0,72 38,7 ICI/40,1	1,19 67 ICI/41,8	1,38 78 ICI/41,8	2,64 140 ICI/39,4	5,3 280 ICI/39,4	6 325 ICI/40,2	11,1 615 ICI/41,4	13,1 733 ICI/41,6	22,5 1 250 ICI/41,4	—	—	—	—	—	—	—
	630	35,5	—	—	—	—	—	—	—	7,5 425 C21/37,5	11,1 630 C21/37,5	15,9 900 C21/37,3	23,9 1 280 C21/35,3	32,8 1 800 C21/36,2	45,5 2 570 C21/37,2	62 3 550 C21/37,5	82 4 500 C21/36,3	102 5 600 C21/36,3	126 7 100 C21/37,3	
	560	31,5	—	—	—	—	—	—	—	7,6 412 C21/32	10,9 615 C21/33,1	15,4 875 C21/33,2	21,5 1 250 C21/34,2	30,5 1 750 C21/33,7	44,3 2 500 C21/33,1	60 3 450 C21/33,7	84 4 500 C21/31,3	105 5 600 C21/31,3	128 7 100 C21/32,5	
	560	31,5	0,292 16 ICI/32,1	0,487 27,4 ICI/33	0,57 32,2 ICI/33	1,15 61 ICI/31,4	1,25 67 ICI/31,4	2,29 128 ICI/32,8	4,65 257 ICI/32,4	—	10,3 553 ICI/31,4	—	20,4 1 140 ICI/32,7	—	—	—	—	—	—	—
560	31,5	—	0,406 21,6 ICI/31,3	0,478 25,5 ICI/31,3	0,81 45 ICI/32,5	0,98 55 ICI/32,5	1,81 93 ICI/30,1	3,54 189 ICI/31,3	—	7,1 372 ICI/30,8	—	14,1 740 ICI/30,8	—	27,9 1 510 ICI/31,7	—	—	—	—	—	
16	1 400	90	—	—	—	—	—	—	—	7,1 425 C21/87,8	10,2 630 C21/90,4	13,7 838 C21/90	21,3 1 280 C21/87,9	29,2 1 800 C21/90,3	42,3 2 570 C21/89	58 3 550 C21/89,7	74 4 500 C21/88,8	-92 5 600 C21/88,8	114 7 100 C21/91,4	
	1 250	80	—	—	—	—	—	—	—	6,9 412 C21/78,6	9,7 615 C21/82,7	13,8 875 C21/83,1	20,1 1 250 C21/81,4	28,6 1 750 C21/80,2	41,5 2 500 C21/78,8	56 3 450 C21/80,3	69 4 370 C21/82,6	84 5 300 C21/82,6	111 6 900 C21/81,2	
	1 250	80	0,253 14,5 ICI/75,2	0,448 27,2 ICI/79,5	0,55 33,5 ICI/79,5	0,92 58 ICI/82,7	1,06 67 ICI/82,7	2,08 122 ICI/76,7	4,07 243 ICI/78,1	5 301 ICI/78,1	8,9 530 ICI/78,1	9,9 606 ICI/80,5	18,3 1 090 ICI/78,1	—	—	—	—	—	—	
	1 120	71	—	—	—	—	—	—	—	7,1 425 C21/70,2	10,2 630 C21/72,3	13,7 838 C21/72	21,3 1 280 C21/70,3	29,2 1 800 C21/72,2	42,3 2 570 C21/71,2	58 3 550 C21/71,7	74 4 500 C21/71,1	92 5 600 C21/71,1	114 7 100 C21/73,1	
	1 000	63	—	—	—	—	—	—	—	7 412 C21/62	9,9 615 C21/65,2	14 875 C21/65,5	20,4 1 250 C21/64,2	29 1 750 C21/63,2	42,2 2 500 C21/62,1	57 3 450 C21/63,3	70 4 370 C21/65,1	85 5 300 C21/65,1	113 6 900 C21/64	
	1 000	63	0,253 14,5 ICI/60,1	0,448 27,2 ICI/63,6	0,55 33,5 ICI/63,6	0,92 58 ICI/66,2	1,06 67 ICI/66,2	2,08 122 ICI/61,3	4,07 243 ICI/62,5	5,9 355 ICI/62,5	8,9 530 ICI/62,5	12,2 750 ICI/64,4	18,3 1 090 ICI/62,5	—	—	—	—	—	—	
	900	56	—	—	—	—	—	—	—	7,2 425 C21/55,4	10,4 630 C21/57	13,9 837 C21/56,8	21,8 1 280 C21/55,5	29,8 1 800 C21/56,9	43,1 2 570 C21/56,1	59 3 550 C21/56,6	76 4 500 C21/56	94 5 600 C21/56	116 7 100 C21/57,6	
	800	50	—	—	—	—	—	—	—	6,8 412 C21/50,4	9,9 615 C21/52,1	14 875 C21/52,4	19,4 1 250 C21/53,9	27,6 1 750 C21/53,1	40,2 2 500 C21/52,1	54 3 450 C21/53,1	71 4 370 C21/51,3	87 5 300 C21/51,3	115 6 900 C21/50,5	
	800	50	0,282 16,5 ICI/49	0,471 28,6 ICI/50,9	0,56 34,3 ICI/50,9	1 63 ICI/53	1,13 71 ICI/53	2,23 133 ICI/49,9	4,69 280 ICI/50	6 355 ICI/49,3	9,8 615 ICI/52,5	12,4 750 ICI/50,8	19,9 1 240 ICI/52,5	—	—	—	—	—	—	
	710	45	—	—	—	—	—	—	—	7 425 C21/45,1	10,3 630 C21/45,6	14,7 900 C21/45,4	20,4 1 280 C21/46,6	28 1 800 C21/47,8	40,5 2 570 C21/47,1	56 3 550 C21/47,5	76 4 500 C21/44,2	94 5 600 C21/44,2	116 7 100 C21/45,4	

Bei  $n_1$  größer als 1 400 min<sup>-1</sup> oder kleiner als 560 min<sup>-1</sup> s. Kap. 6 und Tabelle auf Seite 54.

For  $n_1$  higher than 1 400 min<sup>-1</sup> or lower than 560 min<sup>-1</sup>, see ch. 6 and table on page 54.

9 - Nennleistungen und Nenndrehmomente (Kegelstirnradgetriebe)  
 9 - Nominal powers and torques (right angle shafts)

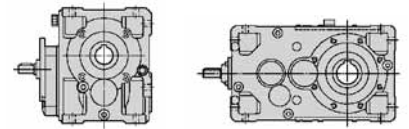

			Getriebegröße - Gear reducer size																	
			$P_{N2}$ kW $M_{N2}$ daN m ... / i																	
$n_{N2}$	$n_1$	$i_N$	50	63	64	80	81	100	125	140	160	180	200	225	250	280	320	321	360	
min <sup>-1</sup>																				
16	630	40	—	—	—	—	—	—	—	7,3 425 C21/38,7	10,5 630 C21/39,5	14,3 887 C21/41	19,8 1 280 C21/42,6	28,7 1 800 C21/41,4	39,6 2 570 C21/42,8	56 3 550 C21/41,6	75 4 500 C21/39,5	93 5 600 C21/39,5	114 7 100 C21/41	
	630	40	0,282 16,5 ICI/38,6	0,52 31,5 ICI/40,1	0,64 38,7 ICI/40,1	1,06 67 ICI/41,8	1,22 78 ICI/41,8	2,35 140 ICI/39,4	4,69 280 ICI/39,4	5,3 325 ICI/40,2	9,8 615 ICI/41,4	11,6 733 ICI/41,6	19,9 1 250 ICI/41,4	—	—	—	—	—	—	—
	560	35,5	—	—	—	—	—	—	—	6,6 425 C21/37,5	9,9 630 C21/37,5	14,1 900 C21/37,3	21,3 1 280 C21/35,3	29,1 1 800 C21/36,2	40,5 2 570 C21/37,2	55 3 550 C21/37,5	73 4 500 C21/36,3	91 5 600 C21/36,3	112 7 100 C21/37,3	
14	1 400	100	—	—	—	—	—	—	—	6,1 412 C21/98,2	8,7 615 C21/103	12,4 875 C21/104	18 1 250 C21/102	25,6 1 750 C21/100	37,2 2 500 C21/98,5	50 3 450 C21/100	62 4 370 C21/103	75 5 300 C21/103	100 6 900 C21/102	
	1 400	100	—	0,34 23,1 ICI/99,4	0,415 28,2 ICI/99,4	0,71 50 ICI/103	0,78 55 ICI/103	1,94 133 ICI/100	4,04 280 ICI/102	5,2 355 ICI/100	8,5 615 ICI/106	9,9 691 ICI/102	17,3 1 240 ICI/106	—	—	—	—	—	—	—
	1 250	90	—	—	—	—	—	—	—	6,3 425 C21/87,8	9,1 630 C21/90,4	12,3 843 C21/90	19,1 1 280 C21/87,9	26,1 1 800 C21/90,3	37,8 2 570 C21/89	52 3 550 C21/89,7	66 4 500 C21/88,8	83 5 600 C21/88,8	102 7 100 C21/91,4	
	1 120	80	—	—	—	—	—	—	—	6,1 412 C21/78,6	8,7 615 C21/82,7	12,4 875 C21/83,1	18 1 250 C21/81,4	25,6 1 750 C21/80,2	37,2 2 500 C21/78,8	50 3 450 C21/80,3	62 4 370 C21/82,6	75 5 300 C21/82,6	100 6 900 C21/81,2	
	1 120	80	0,226 14,5 ICI/75,2	0,401 27,2 ICI/79,5	0,494 33,5 ICI/79,5	0,82 58 ICI/82,7	0,95 67 ICI/82,7	1,87 122 ICI/76,7	3,65 243 ICI/78,1	4,52 301 ICI/78,1	8 530 ICI/78,1	8,8 606 ICI/80,5	16,4 1 090 ICI/78,1	—	—	—	—	—	—	—
	1 000	71	—	—	—	—	—	—	—	6,3 425 C21/70,2	9,1 630 C21/72,3	12,3 843 C21/72	19,1 1 280 C21/70,3	26,1 1 800 C21/72,2	37,8 2 570 C21/71,2	52 3 550 C21/71,7	66 4 500 C21/71,1	83 5 600 C21/71,1	102 7 100 C21/73,1	
	900	63	—	—	—	—	—	—	—	6,3 412 C21/62	8,9 615 C21/65,2	12,6 875 C21/65,5	18,4 1 250 C21/64,2	26,1 1 750 C21/63,2	37,9 2 500 C21/62,1	51 3 450 C21/63,3	63 4 370 C21/65,1	77 5 300 C21/65,1	102 6 900 C21/64	
	900	63	0,227 14,5 ICI/60,1	0,403 27,2 ICI/63,6	0,496 33,5 ICI/63,6	0,83 58 ICI/66,2	0,95 67 ICI/66,2	1,87 122 ICI/61,3	3,66 243 ICI/62,5	5,4 355 ICI/62,5	8 530 ICI/62,5	11 750 ICI/64,4	16,4 1 090 ICI/62,5	—	—	—	—	—	—	—
	800	56	—	—	—	—	—	—	—	6,4 425 C21/55,4	9,3 630 C21/57	12,4 843 C21/56,8	19,3 1 280 C21/55,5	26,5 1 800 C21/56,9	38,4 2 570 C21/56,1	53 3 550 C21/56,6	67 4 500 C21/56	84 5 600 C21/56	103 7 100 C21/57,6	
	710	50	—	—	—	—	—	—	—	6,1 412 C21/50,4	8,8 615 C21/52,1	12,4 875 C21/52,4	17,2 1 250 C21/53,9	24,5 1 750 C21/53,1	35,6 2 500 C21/52,1	48,3 3 450 C21/53,1	63 4 370 C21/51,3	77 5 300 C21/51,3	102 6 900 C21/50,5	
	710	50	0,251 16,5 ICI/49	0,418 28,6 ICI/50,9	0,5 34,3 ICI/50,9	0,89 63 ICI/53	1 71 ICI/53	1,97 133 ICI/49,9	4,16 280 ICI/50	5,4 355 ICI/49,3	8,7 615 ICI/52,5	11 750 ICI/50,8	17,6 1 240 ICI/52,5	—	—	—	—	—	—	—
	630	45	—	—	—	—	—	—	—	6,2 425 C21/45,1	9,1 630 C21/45,6	13,1 900 C21/45,4	18,1 1 280 C21/46,6	24,8 1 800 C21/47,8	36 2 570 C21/47,1	49,3 3 550 C21/47,5	67 4 500 C21/44,2	84 5 600 C21/44,2	103 7 100 C21/45,4	
	560	40	—	—	—	—	—	—	—	6,4 425 C21/38,7	9,3 630 C21/39,5	12,8 892 C21/41	17,6 1 280 C21/42,6	25,5 1 800 C21/41,4	35,2 2 570 C21/42,8	50 3 550 C21/41,6	67 4 500 C21/39,5	83 5 600 C21/39,5	102 7 100 C21/41	
	560	40	0,251 16,5 ICI/38,6	0,46 31,5 ICI/40,1	0,57 38,7 ICI/40,1	0,94 67 ICI/41,8	1,09 78 ICI/41,8	2,09 140 ICI/39,4	4,16 280 ICI/39,4	4,74 325 ICI/40,2	8,7 615 ICI/41,4	10,3 733 ICI/41,6	17,7 1 250 ICI/41,4	—	—	—	—	—	—	—
11,2	1 400	125	—	—	—	—	—	—	—	4,28 358 C21/123	7 615 C21/129	9 798 C21/130	14,4 1 250 C21/127	18 1 540 C21/125	29,8 2 500 C21/123	36 3 080 C21/125	49,6 4 370 C21/129	60 5 300 C21/129	71 6 140 C21/127	
	1 400	125	—	—	—	—	—	1,45 122 ICI/123	2,8 243 ICI/127	4,09 355 ICI/127	6,2 530 ICI/126	8,5 750 ICI/130	12,7 1 090 ICI/126	—	—	—	—	—	—	
	1 120	100	—	—	—	—	—	—	—	4,92 412 C21/98,2	7 615 C21/103	9,9 875 C21/104	14,4 1 250 C21/102	20,5 1 750 C21/100	29,8 2 500 C21/98,5	40,3 3 450 C21/100	49,6 4 370 C21/103	60 5 300 C21/103	80 6 900 C21/102	
	1 120	100	—	0,275 23,3 ICI/99,4	0,335 28,4 ICI/99,4	0,58 51 ICI/103	0,63 56 ICI/103	1,55 133 ICI/100	3,23 280 ICI/102	4,15 355 ICI/100	6,8 615 ICI/106	8 699 ICI/102	13,8 1 240 ICI/106	—	—	—	—	—	—	—
	1 000	90	—	—	—	—	—	—	—	5,1 425 C21/87,8	7,3 630 C21/90,4	9,9 853 C21/90	15,2 1 280 C21/87,9	20,9 1 800 C21/90,3	30,2 2 570 C21/89	41,5 3 550 C21/89,7	53 4 500 C21/88,8	66 5 600 C21/88,8	81 7 100 C21/91,4	
	900	80	—	—	—	—	—	—	—	4,94 412 C21/78,6	7 615 C21/82,7	9,9 875 C21/83,1	14,5 1 250 C21/81,4	20,6 1 750 C21/80,2	29,9 2 500 C21/78,8	40,5 3 450 C21/80,3	49,9 4 370 C21/82,6	60 5 300 C21/82,6	80 6 900 C21/81,2	

Bei  $n_1$  größer als 1 400 min<sup>-1</sup> oder kleiner als 560 min<sup>-1</sup> s. Kap. 6 und Tabelle auf Seite 54.

For  $n_1$  higher than 1 400 min<sup>-1</sup> or lower than 560 min<sup>-1</sup>, see ch. 6 and table on page 54.

9 - Nennleistungen und Nenndrehmomente (Kegelstirradgetriebe)  
 9 - Nominal powers and torques (right angle shafts)

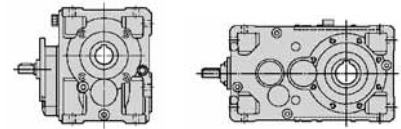

			Getriebegröße - Gear reducer size																	
$n_{N2}$	$n_1$	$i_N$	$P_{N2}$ kW $M_{N2}$ daNm ... // i																	
			50	63	64	80	81	100	125	140	160	180	200	225	250	280	320	321	360	
<b>11,2</b>	900	80	0,182 14,5 ICI/75,2	0,322 27,2 ICI/79,5	0,397 33,5 ICI/79,5	0,66 58 ICI/82,7	0,76 67 ICI/82,7	1,5 122 ICI/76,7	2,93 243 ICI/78,1	3,64 301 ICI/78,1	6,4 530 ICI/78,1	7,1 606 ICI/80,5	13,1 1 090 ICI/78,1	—	—	—	—	—	—	
	800	71	—	—	—	—	—	—	—	5,1 425 C21/70,2	7,3 630 C21/72,3	9,9 853 C21/72	15,2 1 280 C21/70,3	20,9 1 800 C21/72,2	30,2 2 570 C21/71,2	41,5 3 550 C21/71,7	53 4 500 C21/71,1	66 5 600 C21/71,1	81 7 100 C21/73,1	
	710	63	—	—	—	—	—	—	—	4,94 412 C21/62	7 615 C21/65,2	9,9 875 C21/65,5	14,5 1 250 C21/64,2	20,6 1 750 C21/63,2	29,9 2 500 C21/62,1	40,5 3 450 C21/63,3	49,9 4 370 C21/65,1	61 5 300 C21/65,1	80 6 900 C21/64	
	710	63	0,179 14,5 ICI/60,1	0,318 27,2 ICI/63,6	0,391 33,5 ICI/63,6	0,65 58 ICI/66,2	0,75 67 ICI/66,2	1,48 122 ICI/61,3	2,89 243 ICI/62,5	4,22 355 ICI/62,5	6,3 530 ICI/62,5	7,7 750 ICI/64,4	13 1 090 ICI/62,5	—	—	—	—	—	—	—
	630	56	—	—	—	—	—	—	—	5,1 425 C21/55,4	7,3 630 C21/57	9,9 853 C21/56,8	15,2 1 280 C21/55,5	20,9 1 800 C21/56,9	30,2 2 570 C21/56,6	41,4 3 550 C21/56,6	53 4 500 C21/56	66 5 600 C21/56	81 7 100 C21/56	81 7 100 C21/57,6
	560	50	—	—	—	—	—	—	—	4,79 412 C21/50,4	6,9 615 C21/52,1	9,8 875 C21/52,4	13,6 1 250 C21/53,9	19,3 1 750 C21/53,1	28,1 2 500 C21/52,1	38,1 3 450 C21/53,1	49,9 4 370 C21/51,3	61 5 300 C21/51,3	80 6 900 C21/50,5	
	560	50	0,198 16,5 ICI/49	0,33 28,6 ICI/50,9	0,395 34,3 ICI/50,9	0,7 63 ICI/53	0,79 71 ICI/53	1,56 133 ICI/49,9	3,28 280 ICI/50	4,22 355 ICI/49,3	6,9 615 ICI/52,5	8,7 750 ICI/50,8	13,9 1 240 ICI/52,5	—	—	—	—	—	—	—
<b>9</b>	1 400	160	—	—	—	—	—	—	—	3,46 355 C21/151	5,1 530 C21/154	6,9 750 C21/158	10,5 1 090 C21/151	14,1 1 500 C21/156	20,5 2 180 C21/156	28,6 3 000 C21/154	35,2 3 750 C21/156	42,2 4 500 C21/156	55 6 000 C21/161	
	1 400	160	—	—	—	—	1,16 122 ICI/154	2,24 243 ICI/159	2,78 301 ICI/159	4,91 526 ICI/157	5,5 606 ICI/162	10,2 1 090 ICI/157	—	—	—	—	—	—	—	
	1 120	125	—	—	—	—	—	—	3,45 361 C21/123	5,6 615 C21/129	7,4 814 C21/130	11,5 1 250 C21/127	14,7 1 570 C21/125	23,8 2 500 C21/123	29,4 3 150 C21/125	39,7 4 370 C21/129	48,2 5 300 C21/129	58 6 270 C21/127		
	1 120	125	—	—	—	—	1,16 122 ICI/123	2,24 243 ICI/127	3,27 355 ICI/127	4,94 530 ICI/126	6,8 750 ICI/130	10,2 1 090 ICI/126	—	—	—	—	—	—	—	
	900	100	—	—	—	—	—	—	3,95 412 C21/98,2	5,6 615 C21/103	7,9 875 C21/104	11,6 1 250 C21/102	16,5 1 750 C21/100	23,9 2 500 C21/98,5	32,4 3 450 C21/100	39,9 4 370 C21/103	48,4 5 300 C21/103	64 6 900 C21/102		
	900	100	—	0,221 23,3 ICI/99,4	0,269 28,4 ICI/99,4	0,464 51 ICI/103	0,51 56 ICI/103	1,25 133 ICI/100	2,59 280 ICI/102	3,34 355 ICI/100	5,5 615 ICI/106	6,5 707 ICI/102	11,1 1 240 ICI/106	—	—	—	—	—	—	
	800	90	—	—	—	—	—	—	4,06 425 C21/87,8	5,8 630 C21/90,4	8 857 C21/90	12,2 1 280 C21/87,9	16,7 1 800 C21/90,3	24,2 2 570 C21/89	33,2 3 550 C21/89,7	42,4 4 500 C21/88,8	53 5 600 C21/88,8	65 7 100 C21/91,4		
	710	80	—	—	—	—	—	—	3,9 412 C21/78,6	5,5 615 C21/82,7	7,8 875 C21/83,1	11,4 1 250 C21/81,4	16,2 1 750 C21/80,2	23,6 2 500 C21/78,8	31,9 3 450 C21/80,3	39,3 4 370 C21/82,6	47,7 5 300 C21/82,6	63 6 900 C21/81,2		
	710	80	0,143 14,5 ICI/75,2	0,254 27,2 ICI/79,5	0,313 33,5 ICI/79,5	0,52 58 ICI/82,7	0,6 67 ICI/82,7	1,18 122 ICI/76,7	2,31 243 ICI/78,1	2,87 301 ICI/78,1	5 530 ICI/78,1	5,6 606 ICI/80,5	10,4 1 090 ICI/78,1	—	—	—	—	—	—	
	630	71	—	—	—	—	—	—	—	3,99 425 C21/70,2	5,7 630 C21/72,3	7,9 857 C21/72	12 1 280 C21/70,3	16,4 1 800 C21/72,2	23,8 2 570 C21/71,2	32,6 3 550 C21/71,7	41,8 4 500 C21/71,1	52 5 600 C21/71,1	64 7 100 C21/73,1	
	560	63	—	—	—	—	—	—	—	3,9 412 C21/62	5,5 615 C21/65,2	7,8 875 C21/65,5	11,4 1 250 C21/64,2	16,2 1 750 C21/63,2	23,6 2 500 C21/62,1	32 3 450 C21/63,3	39,4 4 370 C21/65,1	47,7 5 300 C21/65,1	63 6 900 C21/64	
560	63	0,141 14,5 ICI/60,1	0,251 27,2 ICI/63,6	0,309 33,5 ICI/63,6	0,51 58 ICI/66,2	0,59 67 ICI/66,2	1,17 122 ICI/61,3	2,28 243 ICI/62,5	3,33 355 ICI/62,5	4,97 530 ICI/62,5	6,8 750 ICI/64,4	10,2 1 090 ICI/62,5	—	—	—	—	—	—		
<b>7,1</b>	1 400	200	—	—	—	—	0,72 94 ICI/192	1,63 221 ICI/199	—	3,24 434 ICI/196	—	6,5 868 ICI/196	—	—	—	—	—	—	—	
	1 120	160	—	—	—	—	—	—	2,77 355 C21/151	4,04 530 C21/154	5,6 750 C21/158	8,4 1 090 C21/151	11,3 1 500 C21/156	16,4 2 180 C21/156	22,9 3 000 C21/154	28,2 3 750 C21/156	33,8 4 500 C21/156	43,7 6 000 C21/161		
	1 120	160	—	—	—	—	0,93 122 ICI/154	1,79 243 ICI/159	2,22 301 ICI/159	3,92 526 ICI/157	4,39 606 ICI/162	8,1 1 090 ICI/157	—	—	—	—	—	—		
	900	125	—	—	—	—	—	—	2,8 364 C21/123	4,49 615 C21/129	6 830 C21/130	9,3 1 250 C21/127	12 1 600 C21/125	19,1 2 500 C21/123	24,1 3 210 C21/125	31,9 4 370 C21/129	38,7 5 300 C21/129	47,5 6 390 C21/127		

Bei  $n_1$  größer als 1 400 min<sup>-1</sup> oder kleiner als 560 min<sup>-1</sup> s. Kap. 6 und Tabelle auf Seite 54.

For  $n_1$  higher than 1 400 min<sup>-1</sup> or lower than 560 min<sup>-1</sup>, see ch. 6 and table on page 54.

9 - Nennleistungen und Nenndrehmomente (Kegelstirnradgetriebe)  
 9 - Nominal powers and torques (right angle shafts)

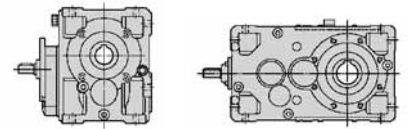

			Getriebegröße - Gear reducer size																	
			$P_{N2}$ kW $M_{N2}$ daN m ... / i																	
$n_{N2}$	$n_1$	$i_N$	50	63	64	80	81	100	125	140	160	180	200	225	250	280	320	321	360	
min <sup>-1</sup>																				
7,1	900	125	—	—	—	—	—	0,93 122 ICI/123	1,8 243 ICI/127	2,63 355 ICI/127	3,97 530 ICI/126	5,5 750 ICI/130	8,2 1 090 ICI/126	—	—	—	—	—	—	
	710	100	—	—	—	—	—	—	—	3,12 412 C21/98,2	4,42 615 C21/103	6,3 875 C21/104	9,1 1 250 C21/102	13 1 750 C21/100	18,9 2 500 C21/98,5	25,6 3 450 C21/100	31,5 4 370 C21/103	38,2 5 300 C21/103	51 6 900 C21/102	
	710	100	—	0,174 23,3 ICI/99,4	0,212 28,4 ICI/99,4	0,366 51 ICI/103	0,399 56 ICI/103	0,98 133 ICI/100	2,05 280 ICI/102	2,63 355 ICI/100	4,33 615 ICI/106	5,2 716 ICI/102	8,8 1 240 ICI/106	—	—	—	—	—	—	—
	630	90	—	—	—	—	—	—	—	3,19 425 C21/87,8	4,6 630 C21/90,4	6,3 857 C21/90	9,6 1 280 C21/87,9	13,2 1 800 C21/90,3	19,1 2 570 C21/89	26,1 3 550 C21/89,7	33,4 4 500 C21/88,8	41,6 5 600 C21/88,8	51 7 100 C21/91,4	
	560	80	—	—	—	—	—	—	—	3,07 412 C21/78,6	4,36 615 C21/82,7	6,2 875 C21/83,1	9 1 250 C21/81,4	12,8 1 750 C21/80,2	18,6 2 500 C21/78,8	25,2 3 450 C21/80,3	31 4 370 C21/82,6	37,6 5 300 C21/82,6	49,8 6 900 C21/81,2	
	560	80	—	0,113 14,5 ICI/75,2	0,201 27,2 ICI/79,5	0,247 33,5 ICI/79,5	0,411 58 ICI/82,7	0,475 67 ICI/82,7	0,93 122 ICI/76,7	1,82 243 ICI/78,1	2,26 301 ICI/78,1	3,98 530 ICI/78,1	4,42 606 ICI/80,5	8,2 1 090 ICI/78,1	—	—	—	—	—	—
5,6	1 120	200	—	—	—	—	—	0,58 94 ICI/192	1,3 221 ICI/199	—	2,59 434 ICI/196	—	5,2 868 ICI/196	—	—	—	—	—	—	
	900	160	—	—	—	—	—	—	—	2,22 355 C21/151	3,25 530 C21/154	4,46 750 C21/158	6,8 1 090 C21/151	9,1 1 500 C21/156	13,2 2 180 C21/156	18,4 3 000 C21/154	22,6 3 750 C21/156	27,1 4 500 C21/156	35,1 6 000 C21/161	
	900	160	—	—	—	—	—	0,75 122 ICI/154	1,44 243 ICI/159	1,79 301 ICI/159	3,15 526 ICI/157	3,53 606 ICI/162	6,5 1 090 ICI/157	—	—	—	—	—	—	
	710	125	—	—	—	—	—	—	—	2,23 368 C21/123	3,54 615 C21/129	4,85 847 C21/130	7,3 1 250 C21/127	9,7 1 640 C21/125	15,1 2 500 C21/123	19,4 3 270 C21/125	25,2 4 370 C21/129	30,5 5 300 C21/129	38,2 6 530 C21/127	
	710	125	—	—	—	—	—	0,74 122 ICI/123	1,42 243 ICI/127	2,08 355 ICI/127	3,13 530 ICI/126	4,31 750 ICI/130	6,4 1 090 ICI/126	—	—	—	—	—	—	
	560	100	—	—	—	—	—	—	—	2,46 412 C21/98,2	3,49 615 C21/103	4,94 875 C21/104	7,2 1 250 C21/102	10,2 1 750 C21/100	14,9 2 500 C21/98,5	20,2 3 450 C21/100	24,8 4 370 C21/103	30,1 5 300 C21/103	39,8 6 900 C21/102	
560	100	—	0,137 23,3 ICI/99,4	0,168 28,4 ICI/99,4	0,289 51 ICI/103	0,315 56 ICI/103	0,78 133 ICI/100	1,61 280 ICI/102	2,08 355 ICI/100	3,42 615 ICI/106	4,16 725 ICI/102	6,9 1 240 ICI/106	—	—	—	—	—	—		
4,5	900	200	—	—	—	—	—	0,463 94 ICI/192	1,05 221 ICI/199	—	2,08 434 ICI/196	—	4,17 868 ICI/196	—	—	—	—	—	—	
	710	160	—	—	—	—	—	—	—	1,75 355 C21/151	2,56 530 C21/154	3,52 750 C21/158	5,3 1 090 C21/151	7,1 1 500 C21/156	10,4 2 180 C21/156	14,5 3 000 C21/154	17,8 3 750 C21/156	21,4 4 500 C21/156	27,7 6 000 C21/161	
	710	160	—	—	—	—	—	0,59 122 ICI/154	1,14 243 ICI/159	1,41 301 ICI/159	2,49 526 ICI/157	2,78 606 ICI/162	5,2 1 090 ICI/157	—	—	—	—	—	—	
	560	125	—	—	—	—	—	—	—	1,77 371 C21/123	2,79 615 C21/129	3,9 864 C21/130	5,8 1 250 C21/127	7,8 1 670 C21/125	11,9 2 500 C21/123	15,6 3 340 C21/125	19,9 4 370 C21/129	24,1 5 300 C21/129	30,8 6 660 C21/127	
560	125	—	—	—	—	—	0,58 122 ICI/123	1,12 243 ICI/127	1,64 355 ICI/127	2,47 530 ICI/126	3,4 750 ICI/130	5,1 1 090 ICI/126	—	—	—	—	—	—		
3,55	710	200	—	—	—	—	—	0,365 94 ICI/192	0,83 221 ICI/199	—	1,64 434 ICI/196	—	3,29 868 ICI/196	—	—	—	—	—	—	
	560	160	—	—	—	—	—	—	—	1,38 355 C21/151	2,02 530 C21/154	2,78 750 C21/158	4,22 1 090 C21/151	5,6 1 500 C21/156	8,2 2 180 C21/156	11,4 3 000 C21/154	14,1 3 750 C21/156	16,9 4 500 C21/156	21,9 6 000 C21/161	
	560	160	—	—	—	—	—	0,465 122 ICI/154	0,9 243 ICI/159	1,11 301 ICI/159	1,96 526 ICI/157	2,2 606 ICI/162	4,07 1 090 ICI/157	—	—	—	—	—	—	
2,8	560	200	—	—	—	—	—	0,288 94 ICI/192	0,65 221 ICI/199	—	1,3 434 ICI/196	—	2,59 868 ICI/196	—	—	—	—	—	—	

Bei  $n_1$  größer als 1 400 min<sup>-1</sup> oder kleiner als 560 min<sup>-1</sup> s. Kap. 6 und Tabelle auf Seite 54.

For  $n_1$  higher than 1 400 min<sup>-1</sup> or lower than 560 min<sup>-1</sup>, see ch. 6 and table on page 54.

9 - Nennleistungen und Nenndrehmomente (Kegelstirradgetriebe)  
 9 - Nominal powers and torques (right angle shafts)

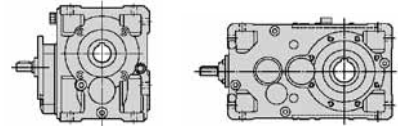

Übersicht Übersetzungen *i*, Drehmomente  $M_{N2}$  [daN m]  
 bei  $n_1 \leq 90 \text{ min}^{-1}$  (Kegelstirradgetriebe) **gültig**

Summary of transmission ratios *i*, torques  $M_{N2}$  [daN m]  
 valid for  $n_1 \leq 90 \text{ min}^{-1}$  (right angle shafts)

Zahnradgetriebe Train of gears	Getriebegröße - Gear reducer size																		
		50	63	64	80	81	100	125	140	160	180	200	225	250	280	320	321	360	
	$i_{N1}$	<i>i</i> daNm	<i>M<sub>N2</sub></i> daNm	<i>i</i> daNm	<i>M<sub>N2</sub></i> daNm	<i>i</i> daNm	<i>M<sub>N2</sub></i> daNm	<i>i</i> daNm	<i>M<sub>N2</sub></i> daNm	<i>i</i> daNm	<i>M<sub>N2</sub></i> daNm	<i>i</i> daNm	<i>M<sub>N2</sub></i> daNm	<i>i</i> daNm	<i>M<sub>N2</sub></i> daNm	<i>i</i> daNm	<i>M<sub>N2</sub></i> daNm	<i>i</i> daNm	<i>M<sub>N2</sub></i> daNm
<b>CI</b>	5	—	—	—	—	—	—	—	—	—	—	—	—	—	—	—	—	—	—
	6,3	6,53	14,4	6,57	25,8	6,57	32,2	6,27	55	6,27	61	6,53	114	6,57	258	8,15	360	8,15	360
	8	7,85	16,5	8 <sup>1)</sup>	31,4	8 <sup>1)</sup>	38,7	8,33	67	8,33	78	7,85	136	8,15	360	8,27	615	8,31	733
	9	—	—	—	—	—	—	—	—	—	—	—	—	—	—	—	—	—	—
	10	10,3	16	10 <sup>1)</sup>	31,5	10 <sup>1)</sup>	38,7	10,4	67	10,4	78	9,81	140	10 <sup>1)</sup>	280	10,2	345	10,3	615
	11,2	—	—	—	—	—	—	—	—	—	—	—	—	—	—	—	—	—	—
	12,5	12,4	16,5	12,6	31,4	12,6	38,7	13,1	67	13,1	78	12,4	136	12,6	280	12,9	360	13	615
	14	—	—	—	—	—	—	—	—	—	—	—	—	—	—	—	—	—	—
	16	15,2	14,5	15,8	27,2	15,8	33,5	16,4 <sup>1)</sup>	58	16,4 <sup>1)</sup>	67	15,2	122	15,8	243	15,8	355	15,5	530
	18	—	—	—	—	—	—	—	—	—	—	—	—	—	—	—	—	—	—
	20	19,3	14,5	20 <sup>1)</sup>	27,2	20 <sup>1)</sup>	33,5	20,8 <sup>1)</sup>	58	20,8 <sup>1)</sup>	67	19,3	122	20 <sup>1)</sup>	243	20 <sup>1)</sup>	355	19,7	530
	25	24,1	14,5	25 <sup>1)</sup>	26,7	25 <sup>1)</sup>	33,5	26 <sup>1)</sup>	58	26 <sup>1)</sup>	67	24,1	115	25 <sup>1)</sup>	243	—	—	24,6	526
31,5	—	—	31,3	22,1	31,3	26	32,5 <sup>1)</sup>	46	32,5 <sup>1)</sup>	56	30,1	94	31,3	196	—	—	30,8	366	
<b>ICI</b>	31,5	32,1	16	33	27,4	33	32,2	31,4	61	31,4	67	32,8	128	32,4	257	—	—	31,4	553
	40	38,6	16,5	40,1	31,5	40,1	38,7	41,8	67	41,8	78	39,4	140	39,4	280	40,2	325	41,4	615
	50	49	16,5	50,9	28,6	50,9	34,3	53	63	53	71	49,9	133	50 <sup>1)</sup>	280	49,3	355	52,5	615
	63	60,1	14,5	63,6	27,2	63,6	33,5	66,2	58	66,2	67	61,3	122	62,5 <sup>1)</sup>	243	62,5	355	62,5	530
	80	75,2	14,5	79,5	27,2	79,5	33,5	82,7	58	82,7	67	76,7	122	78,1	243	78,1	301	78,1	530
	100	—	—	99,4	23,3	99,4	28,4	103	51	103	56	100	133	102	280	100	355	106	615
<b>C2I</b>	20	—	—	—	—	—	—	—	—	—	—	—	—	—	—	—	—	—	—
	22,4	—	—	—	—	—	—	—	—	—	—	—	—	—	—	—	—	—	—
	25	—	—	—	—	—	—	—	—	—	—	—	—	—	—	—	—	—	—
	28	—	—	—	—	—	—	—	—	—	—	—	—	—	—	—	—	—	—
	31,5	—	—	—	—	—	—	—	—	—	—	—	—	—	—	—	—	—	—
	35,5	—	—	—	—	—	—	—	—	—	—	—	—	—	—	—	—	—	—
	40	—	—	—	—	—	—	—	—	—	—	—	—	—	—	—	—	—	—
	45	—	—	—	—	—	—	—	—	—	—	—	—	—	—	—	—	—	—
	50	—	—	—	—	—	—	—	—	—	—	—	—	—	—	—	—	—	—
	56	—	—	—	—	—	—	—	—	—	—	—	—	—	—	—	—	—	—
	63	—	—	—	—	—	—	—	—	—	—	—	—	—	—	—	—	—	—
71	—	—	—	—	—	—	—	—	—	—	—	—	—	—	—	—	—	—	
80	—	—	—	—	—	—	—	—	—	—	—	—	—	—	—	—	—	—	
90	—	—	—	—	—	—	—	—	—	—	—	—	—	—	—	—	—	—	
100	—	—	—	—	—	—	—	—	—	—	—	—	—	—	—	—	—	—	
125	—	—	—	—	—	—	—	—	—	—	—	—	—	—	—	—	—	—	
160	—	—	—	—	—	—	—	—	—	—	—	—	—	—	—	—	—	—	

1) Endliche Übersetzungen.

1) Finite transmission ratios.

# 10 - Bauarten, Abmessungen, Bauformen und Ölmengen

# 10 - Designs, dimensions, mounting positions and oil quantities

R CI 50 ... 100

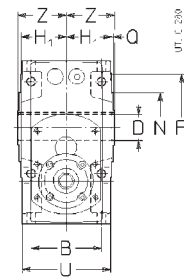
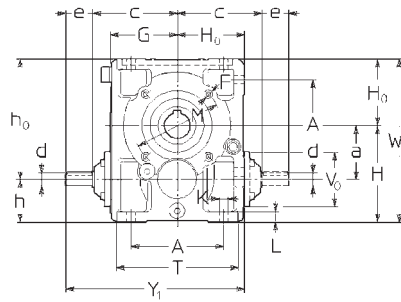

## Bauart (Drehsinn)

## Design (direction of rotation)

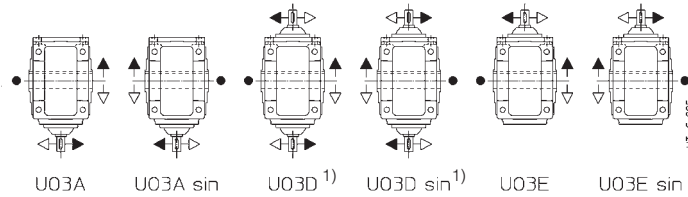

● Position der Bezugsrille (s. Kap. 20) zur Ermittlung der Radialbelastung.  
 1) Nicht möglich für Größe 50 mit  $i_h \leq 8$ .

● Position of the reference groove (see ch. 20) for verification of radial load.  
 1) Not possible for size 50 with  $i_h \leq 8$ .

Größe Size	a	A	B	c		D Ø H7	d e Y <sub>1</sub>			d e Y <sub>1</sub>			F	H	H <sub>0</sub>	H <sub>1</sub>	h	h <sub>0</sub>	K Ø	L	M Ø	N Ø h6	P	Q	T	U	V <sub>0</sub> Ø	W <sub>1</sub>	Z	Masse Mass kg			
				$i_h \leq 8$	$i_h \geq 10$		$i_h \leq 8$	$i_h = 10 \dots 16$	$i_h \geq 20$																								
<b>50</b>	50	86	75	100	94	24	16	30	197	16	30	191	14	30	191	M6	100	67	49	50	117	9,5	12	85	70	105	2,5	120	95	78	167	53	9
<b>63</b>	63	102	90	119	108	30	19	40	239	16	30	218	14	30	218	M8	125	80	58,5	62	143	11,5	14	100	80	120	3	143	114	78	205	63	14
<b>64</b>	63	102	90	119	108	32	19	40	239	16	30	218	14	30	218	M8	125	80	58,5	62	143	11,5	14	100	80	120	3	143	114	78	205	63	14
<b>80</b>	80	132	106	142	131	38	24	50	292	19	40	271	16	30	261	M10	150	100	69,5	70	180	14	17	130	110	160	3,5	180	135	86	250	75	25
<b>81</b>	80	132	106	142	131	40	24	50	292	19	40	271	16	30	261	M10	150	100	69,5	70	180	14	17	130	110	160	3,5	180	135	86	250	75	25
<b>100</b>	100	172	131	168	157	48	28	60	353	24	50	332	19	40	322	M12	180	125	84,5	80	225	16	20	165	130	200	3,5	228	165	104	305	90	45

1) Nutzlänge des Gewindes 2 · F.

1) Working length of thread 2 · F.

## Bauformen und Ölmengen [l]

## Mounting positions and oil quantities [l]

	B3	B6	B7	B8	V5	V6	Größe Size	B3	B6, B7	B8	V5, V6
							<b>50</b>	0,4	0,4	0,6	0,45
							<b>63, 64</b>	0,8	0,8	1	0,95
							<b>80, 81</b>	1,3	1,3	2	1,8
							<b>100</b>	2,6	2,9	3,8	3,5

Falls nicht anders angegeben, werden die Getriebe in der normalen Bauform **B3** geliefert, die als solche **nicht** in der Bezeichnung aufzutreten braucht.

Unless otherwise stated, gear reducers are supplied in mounting position **B3** which, being standard, is **omitted** from the designation.

10 - Bauarten, Abmessungen, Bauformen und Ölmengen

10 - Designs, dimensions, mounting positions and oil quantities

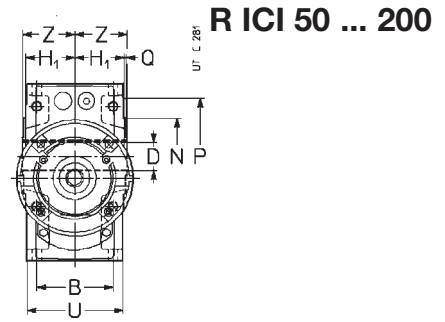
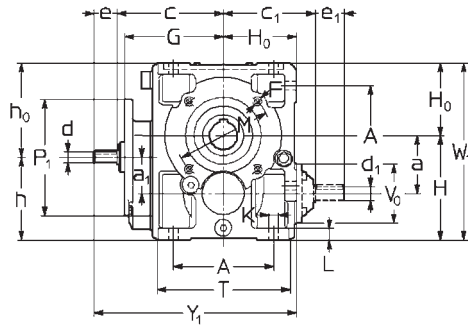

Bauart (Drehsinn)

Design (direction of rotation)

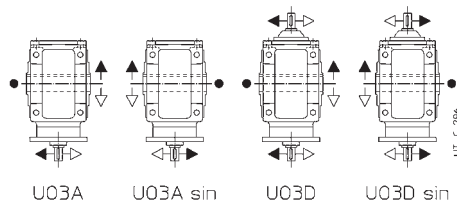

● Position der Bezugsrille (s. Kap. 20) zur Ermittlung der Radialbelastung.

● Position of the reference groove (see ch. 20) for verification of radial load.

Größe Size	a	a <sub>1</sub>	A	B	c	c <sub>1</sub>	D Ø H7	d Ø	e	Y <sub>1</sub>	d <sub>1</sub> Ø	e <sub>1</sub>	d <sub>1</sub> Ø	e <sub>1</sub>	F	G	H	H <sub>0</sub>	H <sub>1</sub>	h	h <sub>0</sub>	K Ø	L	M Ø	N Ø h6	P	P <sub>1</sub>	Q	T	U	V <sub>0</sub> Ø	W <sub>1</sub>	Z	Masse Mass kg			
<b>50</b>	50	40	86	75	107	94	24	11	23	197	—	—	—	16	30	14	30	M6	98	100	67	49	90	77	9,5	12	85	70	105	140 <sup>3)</sup>	2,5	120	95	78	167	53	11
<b>63</b>	63	50	102	90	127	108	30	14	30	237	14	30	237	16	30	14	30	M8	118	125	80	58,5	112	93	11,5	14	100	80	120	160 <sup>3)</sup>	3	143	114	78	205	63	17
<b>64</b>	63	50	102	90	127	108	32	14	30	237	14	30	237	16	30	14	30	M8	118	125	80	58,5	112	93	11,5	14	100	80	120	160 <sup>3)</sup>	3	143	114	78	205	63	17
<b>80</b>	80	50	132	106	147	131	38	14	30	277	14	30	277	19	40	16	30	M10	138	150	100	69,5	120	130	14	17	130	110	160	160 <sup>3)</sup>	3,5	180	135	86	250	75	28
<b>81</b>	80	50	132	106	147	131	40	14	30	277	14	30	277	19	40	16	30	M10	138	150	100	69,5	120	130	14	17	130	110	160	160 <sup>3)</sup>	3,5	180	135	86	250	75	28
<b>100</b>	100	63	172	131	181	157	48	19	40	346	16	30	336	24	50	19	40	M12	170	180	125	84,5	143	162	16	20	165	130	200	200	3,5	228	165	104	305	90	50
<b>125</b>	125	80	212	162	216	188	60	24	50	416	19	40	406	28	60	24	50	2)	205	225	150	103,5	180	195	18	23	215	180	250	200	4	274	201	122	375	110	88
<b>140</b>	140	80	212	162	216	188	70	24	50	416	19	40	406	28	60	24	50	2)	205	240	150	103,5	180	210	18	23	265	230	300	200	4	274	201	122	390	125	102
<b>160</b>	160	100	252	201	258	226	80	28	60	498	24	50	488	38	80	32	80	2)	247	280	180	128,5	220	240	22	28	265	230	300	250	4	328	249	155	460	136	164
<b>180</b>	180	100	252	201	258	226	90	28	60	498	24	50	488	38	80	32	80	2)	247	300	180	128,5	220	260	22	28	300	250	350	250	5	328	249	155	480	150	188
<b>200</b>	200	125	320	250	318	282	100	32	80	623	32	80	623	48	110	38	80	2)	305	355	225	158	280	300	27	34	350	300	400	300	5	410	307	190	580	167	296

- 1) Nutzlänge des Gewindes 2 · F.
- 2) Abmessung, Zahl und Winkelposition s. Kap. 20.
- 3) Viereckiger Flansch: für Abmessungen s. Kap. 20.
- 4) Für die Größen 140 und 180 sind die Abmessungen für  $i_N \leq 50$  und  $i_N = 100$  gültig.
- 5) Für die Größen 140 und 180 sind die Abmessungen für folgende Übersetzungsgängigkeit:  $i_N = 63$ ,  $i_N = 80$ ,  $i_N = 125$  und  $i_N = 160$ .

- 1) Working length of thread 2 · F.
- 2) For dimension, number and angular position see ch. 20.
- 3) Square flange: for dimensions see ch. 20.
- 4) For sizes 140 and 180 the dimensions are valid for  $i_N \leq 50$  and  $i_N = 100$ .
- 5) For sizes 140 and 180 the dimensions are valid for the following transmission ratios:  $i_N = 63$ ,  $i_N = 80$ ,  $i_N = 125$  and  $i_N = 160$ .

Bauformen und Ölmengen [l]

Mounting positions and oil quantities [l]

Größe Size	B3, B7	B6	B8	V5, V6
<b>50</b>	0,45	0,8	0,65	0,5
<b>63, 64</b>	1	1,6	1,2	1,15
<b>80, 81</b>	1,6	2,7	2,2	2
<b>100</b>	3	5,8	4,2	3,8
<b>125</b>	6	11,6	9	7
<b>140</b>	6,8	13,7	10,6	8,3
<b>160</b>	10,6	21	16	13
<b>180</b>	11,9	24,8	18,9	15,3
<b>200</b>	20	40	30	24

Falls nicht anders angegeben, werden die Getriebe in der normalen Bauform B3 geliefert, die als solche nicht in der Bezeichnung aufzutreten braucht.

Unless otherwise stated, gear reducers are supplied in mounting position B3 which, being standard, is omitted from the designation.



10 - Bauarten, Abmessungen, Bauformen und Ölmenngen

10 - Designs, dimensions, mounting positions and oil quantities

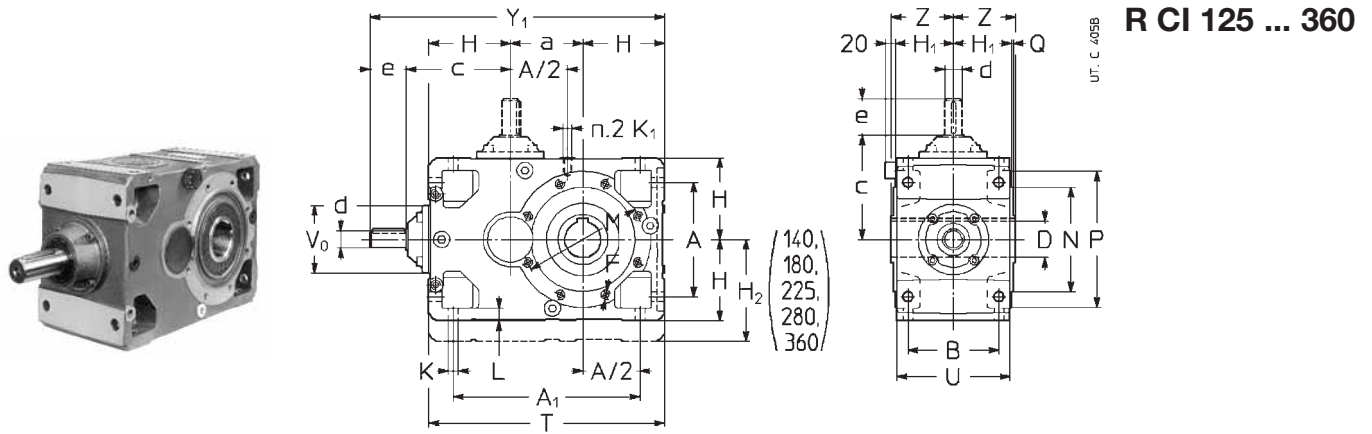

Bauart (Drehsinn)

Design (direction of rotation)

● Position der Bezugsrille (s. Kap. 20) zur Ermittlung der Radialbelastung.

● Position of the reference groove (see ch. 20) for verification of radial load.

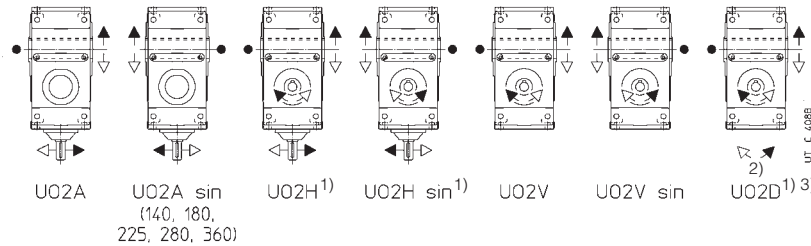

- 1) Nicht möglich für  $i_N \leq 6,3$ , ( $i_N \leq 8$  für Größen 140, 180, 225,  $i_N \leq 9$  für Größen 280 und 360).
- 2) Drehsinn der nicht gezeigten, zweiten vorstehenden schnelllaufenden Welle.
- 3) **Nicht mögliche** Bauart für Größen 140, 180, 225, 280 und 360.

- 1) Not possible for  $i_N \leq 6,3$ , ( $i_N \leq 8$  for sizes 140, 180, 225,  $i_N \leq 9$  for sizes 280 and 360).
- 2) Direction of rotation of the second high speed shaft extension not in view.
- 3) Design **not possible** for sizes 140, 180, 225, 280 and 360.

Größe Size	a	A	A <sub>1</sub>	B	c i <sub>N</sub>	D Ø H7	d	e	Y <sub>1</sub>	i <sub>N</sub> ≥ 18			F	H h11	H <sub>1</sub> h12	H <sub>2</sub> h11	K Ø	K <sub>1</sub>	L	M Ø	N Ø h6	P Ø	Q	T	U	V <sub>0</sub> Ø	Z	Masse Mass kg			
										d	e	Y <sub>1</sub>																			
125	125	212	337	162	≤ 8 ≥ 9	60	38	80	557	28	60	523	24	50	513	3)	150	103,5	—	18	M12	23	215	180	250	4	425	201	122	110	89
140	140	212	352	162	≤ 9 ≥ 10	70	38	80	572	28	60	538	24	50	528	3)	150	103,5	180	18	M12	23	265	230	300	4	440	201	122	125	102
160	160	252	412	201	≤ 8 ≥ 9	80	48	110	696	38	80	646	32	80	646	M16	180	128,5	—	22	M16	28	265	230	300	4	520	249	155	136	158
180	180	252	432	201	≤ 9 ≥ 10	90	48	110	716	38	80	666	32	80	666	M16	180	128,5	225	22	M16	28	300	250	350	5	540	249	155	150	181
200	200	320	520	250	≤ 8 ≥ 9	100	55	110	840	48	110	817	38	80	787	3)	225	158	—	27	M20	34	350	300	400	5	650	307	190	167	282
225	225	320	545	250	≤ 9 ≥ 10	110	55	110	865	48	110	842	38	80	812	M20	225	158	280	27	M20	34	400	350	450	5	675	307	190	180	324
250	250	396	646	310	≤ 10 ≥ 11,2	125	70	140	1050	55	110	997	48	110	997	3)	280	195	—	33	M24	42	500	450	550	5	810	380	238	206	495
280	280	396	676	310	≤ 11,2 ≥ 12,5	140	70	140	1080	55	110	1027	48	110	1027	M24	280	195	355	33	M24	42	500	450	550	5	840	380	238	222	568
320, 321	320	510	830	386	480	160	90	170	1325	70	140	1295	70	140	1295	3)	355	241	—	39	M30	52	600	550	660	6	1030	470	290	254	882
360	360	510	870	386	480	180	90	170	1365	70	140	1335	70	140	1335	M30	355	241	450	39	M30	52	600	550	660	6	1070	470	290	273	1013

- 1) Nutzlänge des Gewindes 2 · F. 2) Nutzlänge des Gewindes 2 · K<sub>1</sub>.
- 3) Abmessung, Zahl und Winkelposition s. Kap. 20.

- 1) Working length of thread 2 · F. 2) Working length of thread 2 · K<sub>1</sub>.
- 3) For dimension, number and angular position see ch. 20.

Bauformen und Ölmenngen [l]

Mounting positions and oil quantities [l]

Bauart - Design	B3				B6				B7				B8				V5		V6		Größe Size	B3	B8	B7	B6, V5, V6	
	UO2A UO2Asin UO2H UO2Hsin				UO2V UO2Vsin UO2D				V5		V6															
	ψ ≥ 250, i <sub>N</sub> ≤ 8				ψ ≥ 160				ψ ≥ 250, i <sub>N</sub> ≤ 8, ● unten - below ≥ 160, ● oben - above		ψ ≥ 125, ● unten - below ≥ 200, ● oben - above															
	ψ ≥ 250, i <sub>N</sub> ≤ 8				ψ ≥ 160				ψ ≥ 250, i <sub>N</sub> ≤ 8, ● unten - below ≥ 160, ● oben - above		ψ ≥ 125, ● unten - below ≥ 200, ● oben - above															
	ψ ≥ 250, i <sub>N</sub> ≤ 8				ψ ≥ 160				ψ ≥ 250, i <sub>N</sub> ≤ 8, ● unten - below ≥ 160, ● oben - above		ψ ≥ 125, ● unten - below ≥ 200, ● oben - above															
	ψ ≥ 250, i <sub>N</sub> ≤ 8				ψ ≥ 160				ψ ≥ 250, i <sub>N</sub> ≤ 8, ● unten - below ≥ 160, ● oben - above		ψ ≥ 125, ● unten - below ≥ 200, ● oben - above															
	ψ ≥ 250, i <sub>N</sub> ≤ 8				ψ ≥ 160				ψ ≥ 250, i <sub>N</sub> ≤ 8, ● unten - below ≥ 160, ● oben - above		ψ ≥ 125, ● unten - below ≥ 200, ● oben - above															
	ψ ≥ 250, i <sub>N</sub> ≤ 8				ψ ≥ 160				ψ ≥ 250, i <sub>N</sub> ≤ 8, ● unten - below ≥ 160, ● oben - above		ψ ≥ 125, ● unten - below ≥ 200, ● oben - above															
	ψ ≥ 250, i <sub>N</sub> ≤ 8				ψ ≥ 160				ψ ≥ 250, i <sub>N</sub> ≤ 8, ● unten - below ≥ 160, ● oben - above		ψ ≥ 125, ● unten - below ≥ 200, ● oben - above															
	ψ ≥ 250, i <sub>N</sub> ≤ 8				ψ ≥ 160				ψ ≥ 250, i <sub>N</sub> ≤ 8, ● unten - below ≥ 160, ● oben - above		ψ ≥ 125, ● unten - below ≥ 200, ● oben - above															

- Falls nicht anders angegeben, werden die Getriebe in der normalen Bauform B3 geliefert, die als solche **nicht** in der Bezeichnung aufzutreten braucht.
- 1) Position der Gewindebohrungen zur Bestimmung der Bauform.
- 2) Größen 140, 180, 225, 280 und 360: Die Nennwärmeleistung P<sub>TN</sub> (Kap. 4) ist mit **0,85** zu multiplizieren.
- ψ ggf. hohe Ölspitzleistung: Die Nennwärmeleistung P<sub>TN</sub> (Kap. 4) ist mit **0,85** (B6 oder ● unten), **0,71** (B7 oder ● oben) zu multiplizieren;
- ☉ ggf. Lagerschmierpumpe: Bei Bedarf bitte rückfragen.
- Unless otherwise stated, gear reducers are supplied in mounting position B3 which, being standard, is **omitted** from the designation.
- 1) Position of tapped holes for identification of mounting position.
- 2) Sizes 140, 180, 225, 280 and 360: nominal thermal power P<sub>TN</sub> (ch. 4) is to be multiplied by **0,85**.
- ψ possible high oil-splash: nominal thermal power P<sub>TN</sub> (ch. 4) is to be multiplied by **0,85** (B6 or ● below), **0,71** (B7 or ● above);
- ☉ possible bearings lubrication pump: consult us if need be.

10 - Bauarten, Abmessungen, Bauformen und Ölmengen

10 - Designs, dimensions, mounting positions and oil quantities

R C2I 140 ... 360

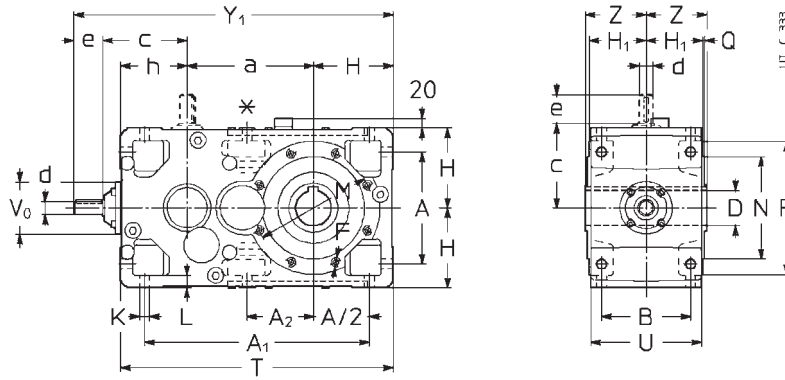
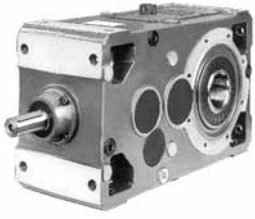

Bauart (Drehsinn)

Design (direction of rotation)

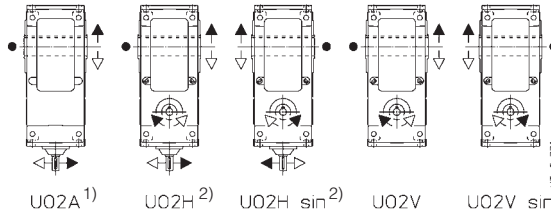

● Position der Bezugsrille (s. Kap. 20) zur Ermittlung der Radialbelastung.  
 1) Das Gehäuse dieser Bauart ist nicht für andere Bauarten vorbereitet.  
 2) Nicht möglich für  $i_n \leq 22,4$  ( $i_n \leq 28$  für Größen 320 ... 360).

● Position of the reference groove (see ch. 20) for verification of radial load.  
 1) In this design casing is not prearranged for other designs.  
 2) Not possible for  $i_n \leq 22,4$  ( $i_n \leq 28$  for sizes 320 ... 360).

Größe Size	a		A	A <sub>1</sub>	A <sub>2</sub>	B	c <i>i<sub>n</sub></i>		D Ø H7	d	e	Y <sub>1</sub>	d	e	Y <sub>1</sub>	d	e	Y <sub>1</sub>	F	H	H <sub>1</sub>	h	K	L	M	N	P	Q	T	U	V <sub>0</sub>	Z	Masse Mass
							$\leq 31,5$	$\geq 35,5$					$i_n \leq 31,5$	$i_n = 35,5 \dots 63$	$i_n \geq 71$				1)	h11	h12	h11	Ø	Ø	Ø h6	Ø						kg	
140	240	212	427	127	162	168	157	70	28	60	618	24	50	597	19	40	587	2)	150	103,5	125	18	23	265	230	300	4	515	201	104	125	111	
160	285	252	507	150*	201	202	188	80	38	80	747	28	60	713	24	50	703	M16	180	128,5	150	22	28	265	230	300	4	615	249	122	136	182	
180	305	252	527	170	201	202	188	90	38	80	767	28	60	733	24	50	723	M16	180	128,5	150	22	28	300	250	350	5	635	249	122	150	200	
200	360	320	635	198*	250	246	226	100	48	110	941	38	80	891	32	80	891	2)	225	158	180	27	34	350	300	400	5	765	307	155	167	321	
225	385	320	660	223	250	246	226	110	48	110	966	38	80	916	32	80	916	M20	225	158	180	27	34	400	350	450	5	790	307	155	180	352	
250	450	396	791	247*	310	305	282	125	55	110	1145	48	110	1122	38	80	1092	2)	280	195	225	33	42	500	450	550	5	955	380	190	206	563	
280	480	396	821	277	310	305	282	140	55	110	1175	48	110	1152	38	80	1122	M24	280	195	225	33	42	500	450	550	5	985	380	190	222	617	
320, 321	570	510	1005	318*	386	380	357	160	70	140	1445	55	110	1392	48	110	1392	2)	355	241	280	39	52	600	550	660	6	1205	470	238	254	991	
360	610	510	1045	358	386	380	357	180	70	140	1485	55	110	1432	48	110	1432	M30	355	241	280	39	52	600	550	660	6	1245	470	238	273	1086	

\* Nur 2 Bohrungen M 16×32 (Größe 160), M 20×38 (Größe 200), M 24×46 (Größe 250) und M 30×58 (Größen 320 und 321) und nicht für Bauart UO2A.  
 1) Nutzlänge des Gewindes 2 · F.  
 2) Abmessung, Zahl und Winkelposition s. Kap. 20.

\* No. 2 holes only M 16×32 (size 160), M 20×38 (size 200), M 24×46 (size 250) and M 30×58 (sizes 320 and 321) except UO2A design.  
 1) Working length of thread 2 · F.  
 2) For dimension, number and angular position see ch. 20.

Bauformen und Ölmenge [l]

Mounting positions and oil quantities [l]

Bauart - Design	B3				B6		B7		B8		V5		V6		Größe Size	B3, B8	B6	B7, V5, V6
	UO2A UO2H UO2Hsin		UO2H ≥ 160 UO2Hsin ≥ 160		V ≥ 320, <i>i<sub>n</sub></i> ≤ 28 V ≥ 160		V ≥ 200				V ≥ 200, ● unten - below V ≥ 320, ● oben - above V ≥ 160, ● unten - above							
Bauart - Design	B3				B6		B7		B8		V5		V6		140	6	10,6	9,5
	B3				B6		B7		B8		V5		V6		160	10	18	16
Bauart - Design	B3				B6		B7		B8		V5		V6		180	10,6	19	17
	B3				B6		B7		B8		V5		V6		200	19	34	30
Bauart - Design	B3				B6		B7		B8		V5		V6		225	20	36	32
	B3				B6		B7		B8		V5		V6		250	36	63	56
Bauart - Design	B3				B6		B7		B8		V5		V6		280	38	67	60
	B3				B6		B7		B8		V5		V6		320,321	67	118	106
Bauart - Design	B3				B6		B7		B8		V5		V6		360	71	126	112
	B3				B6		B7		B8		V5		V6					

Falls nicht anders angegeben, werden die Getriebe in der normalen Bauform B3 geliefert, die als solche nicht in der Bezeichnung aufzutreten braucht.  
 1) Position der Gewindebohrungen zur Bestimmung der Bauform.  
 V ggf. hohe Ölspritzleistung: Die Nennwärmeleistung P<sub>N</sub> (Kap. 4) ist mit 0,85 (B6 oder ● unten), 0,71 (B7 oder ● oben) zu multiplizieren;  
 V ggf. Lagerschmierpumpe: Bei Bedarf bitte rückfragen.

Unless otherwise stated, gear reducers are supplied in mounting position B3 which, being standard, is omitted from the designation.  
 1) Position of intermediate hole for identification of mounting position.  
 V possible high oil-splash: nominal thermal power P<sub>N</sub> (ch. 4) is to be multiplied by 0,85 (B6 or ● above), 0,71 (B7 or ● below);  
 V possible bearings lubrication pump: consult us if need be.









11 - Herstellungsprogramm (Stirnradgetriebemotoren)  
 11 - Manufacturing programme (parallel shafts)

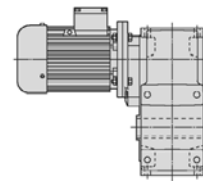

P <sub>1</sub> kW	n <sub>2</sub> min <sup>-1</sup>	M <sub>2</sub> daNm	f <sub>s</sub>	Getriebe - Motor Gear reducer - Motor	i	
1)				2)		
1,5	35,8	37,6	0,85	MR 3I 63 - 90 L	4 39,1	
	34,3	39,2	1	MR 3I 64 - 90 L	4 40,8	
	35,9	38,3	0,85	MR 2I 64 - 90 LC	6 25,1	
	33,6	40,1	1,7	MR 3I 80 - 90 L	4 41,7	
	33,6	40,1	1,9	MR 3I 81 - 90 L	4 41,7	
	34,6	39,7	1,5	MR 2I 80 - 90 LC	6 26	
	34,6	39,7	1,7	MR 2I 81 - 90 LC	6 26	
	34,6	39,7	1,5	MR 2I 80 - 100 LA	6 26	
	34,6	39,7	1,7	MR 2I 81 - 100 LA	6 26	
	34,3	39,3	3,55	MR 3I 100 - 90 L	4 40,8	
	37,9	36,2	3,35	MR 2I 100 - 100 LA	6 23,7	
	43,6	30,9	1	MR 3I 63 - 90 L	4 32,1	
	41,7	32,3	1,25	MR 3I 64 - 90 L	4 33,5	
	46,7	29,4	1,06	MR 2I 63 - 90 LC	6 19,3	
	44,8	30,7	1,25	MR 2I 64 - 90 LC	6 20,1	
	44,7	30,1	2,24	MR 3I 80 - 90 L	4 31,3	
	43,2	31,8	2,12	MR 2I 80 - 90 LC	6 20,8	
	43,2	31,8	2,12	MR 2I 80 - 100 LA	6 20,8	
	52,8	25,5	1,25	MR 3I 63 - 90 L	4 26,5	
	50,7	26,6	1,4	MR 3I 64 - 90 L	4 27,6	
	58,1	23,7	1,12	MR 2I 63 - 90 L	4 24,1	
	55,9	24,6	1,32	MR 2I 64 - 90 L	4 25,1	
	56,8	24,2	1,32	MR 2I 63 - 90 LC	6 15,8	
	54,5	25,2	1,6	MR 2I 64 - 90 LC	6 16,5	
	51,1	26,3	2,5	MR 3I 80 - 90 L	4 27,4	
	53,8	25,5	2,24	MR 2I 80 - 90 L	4 26	
	64,2	21	1,5	MR 3I 63 - 90 L	4 21,8	
	61,6	21,9	1,8	MR 3I 64 - 90 L	4 22,7	
	72,6	18,9	1,6	MR 2I 63 - 90 L	4 19,3	
	69,7	19,7	1,9	MR 2I 64 - 90 L	4 20,1	
	68	19,8	3,35	MR 3I 80 - 90 L	4 20,6	
	67,2	20,5	3,15	MR 2I 80 - 90 L	4 20,8	
	85,6	16,1	1	MR 2I 50 - 80 D	4 16,3	
	88,4	15,6	2	MR 2I 63 - 90 L	4 15,8	
	89,4	15,4	4,25	MR 2I 80 - 90 L	4 15,7	
	114	12,1	1,32	MR 2I 50 - 80 D	4 12,3	
	107	12,8	2,36	MR 2I 63 - 90 L	4 13,1	
	102	13,4	4,75	MR 2I 80 - 90 L	4 13,7	
	137	10,1	1,6	MR 2I 50 - 80 D	4 10,2	
	130	10,5	3	MR 2I 63 - 90 L	4 10,7	
	175	7,9	2,12	MR 2I 50 - 80 D	4 8,01	
	169	8,1	3,75	MR 2I 63 - 90 L	4 8,26	
	218	6,3	2,36	MR 2I 50 - 80 D	4 6,42	
	214	6,4	4,25	MR 2I 63 - 90 L	4 6,53	
	1,85	5,95	273	0,9	MR 4I 125 - 90 LB	4 235
		5,89	276	1	MR 4I 125 - 100 LB	6 153
		7,44	219	1,32	MR 4I 125 - 90 LB	4 188
7,34		226	1,6	MR 3I 140 - 100 LB	6 123	
7,06		235	2,24	MR 3I 160 - 100 LB	6 128	
9,06		179	1,6	MR 4I 125 - 90 LB	4 155	
9		185	2,24	MR 3I 140 - 100 LB	6 100	
10,1		165	2,65	MR 3I 140 - 100 LB	6 89,4	
10,8		151	0,95	MR 4I 100 - 90 LB	4 130	
12,8		130	0,85	MR 3I 100 - 90 LB	4 110	
11		148	1,9	MR 4I 125 - 90 LB	4 128	
12		139	1,7	MR 3I 125 - 100 LB	6 75,3	
11,1		150	2,8	MR 3I 140 - 100 LB	6 81,4	
14,1		115	1,18	MR 4I 100 - 90 LB	4 99,3	
15,5		107	1,12	MR 3I 100 - 90 LB	4 90,1	
15,6		106	1	MR 3I 100 - 100 LB	6 57,7	
15,1		110	2,24	MR 3I 125 - 90 LB	4 92,9	
14,7		113	2,12	MR 3I 125 - 100 LB	6 61,1	
16,9		96	1,5	MR 4I 100 - 90 LB	4 82,7	
18,5		90	1,4	MR 3I 100 - 90 LB	4 75,5	
19,1		87	1,25	MR 3I 100 - 90 LB	4 73,2	
19		88	1,4	MR 3I 100 - 100 LB	6 47,4	
18,6		89	2,8	MR 3I 125 - 90 LB	4 75,3	
18,4		90	3,15	MR 3I 125 - 100 LB	6 48,9	
21,2		78	0,85	MR 3I 81 - 90 LB	4 66	
23,3		71	1,7	MR 3I 100 - 90 LB	4 60,2	

P <sub>1</sub> kW	n <sub>2</sub> min <sup>-1</sup>	M <sub>2</sub> daNm	f <sub>s</sub>	Getriebe - Motor Gear reducer - Motor	i	
1)				2)		
1,85	23,3	71	2	MR 3I 100 - 100 LB	6 38,6	
	23,2	71	4	MR 3I 125 - 90 LB	4 60,2	
	26,5	63	1,06	MR 3I 80 - 90 LB	4 52,9	
	26,9	62	0,95	MR 3I 80 - 90 LB	4 52	
	26,5	63	1,25	MR 3I 81 - 90 LB	4 52,9	
	26,9	62	1,06	MR 3I 81 - 90 LB	4 52	
	28,6	58	2,36	MR 3I 100 - 90 LB	4 49	
	31,2	54	2	MR 2I 100 - 100 LB	6 28,8	
	33,6	49,4	1,32	MR 3I 80 - 90 LB	4 41,7	
	33,6	49,4	1,6	MR 3I 81 - 90 LB	4 41,7	
	34,6	49	1,18	MR 2I 80 - 100 LB	6 26	
	34,6	49	1,4	MR 2I 81 - 100 LB	6 26	
	34,3	48,4	2,8	MR 3I 100 - 90 LB	4 40,8	
	37,9	44,7	2,8	MR 2I 100 - 100 LB	6 23,7	
	44,7	37,2	1,8	MR 3I 80 - 90 LB	4 31,3	
	44,7	37,2	2,12	MR 3I 81 - 90 LB	4 31,3	
	43,2	39,3	1,7	MR 2I 80 - 100 LB	6 20,8	
	43,2	39,3	2	MR 2I 81 - 100 LB	6 20,8	
	58,1	29,2	0,9	MR 2I 63 - 90 LB	4 24,1	
	55,9	30,4	1,06	MR 2I 64 - 90 LB	4 25,1	
	51,1	32,5	2	MR 3I 80 - 90 LB	4 27,4	
	51,1	32,5	2,36	MR 3I 81 - 90 LB	4 27,4	
	53,8	31,5	1,8	MR 2I 80 - 90 LB	4 26	
	53,8	31,5	2,12	MR 2I 81 - 90 LB	4 26	
	72,6	23,3	1,32	MR 2I 63 - 90 LB	4 19,3	
	69,7	24,3	1,6	MR 2I 64 - 90 LB	4 20,1	
	68	24,4	2,8	MR 3I 80 - 90 LB	4 20,6	
	67,2	25,2	2,65	MR 2I 80 - 90 LB	4 20,8	
	88,4	19,2	1,6	MR 2I 63 - 90 LB	4 15,8	
	84,7	20	2	MR 2I 64 - 90 LB	4 16,5	
	89,4	19	3,55	MR 2I 80 - 90 LB	4 15,7	
	107	15,8	1,9	MR 2I 63 - 90 LB	4 13,1	
	102	16,6	4	MR 2I 80 - 90 LB	4 13,7	
	130	13	2,36	MR 2I 63 - 90 LB	4 10,7	
	136	12,5	5,3	MR 2I 80 - 90 LB	4 10,3	
	169	10	3,15	MR 2I 63 - 90 LB	4 8,26	
	214	7,9	3,55	MR 2I 63 - 90 LB	4 6,53	
	2,2	5,89	328	0,85	MR 4I 125 - 112 M	6 153
		7,44	260	1,06	MR 4I 125 - 90 LC	4 188
		7,33	264	0,9	MR 4I 125 - 100 LA	4 191
		7,34	269	1,32	MR 3I 140 - 112 M	6 123
		7,06	280	1,9	MR 3I 160 - 112 M	6 128
		6,85	288	2,65	MR 3I 180 - 112 M	6 131
		9,06	213	1,32	MR 4I 125 - 90 LC	4 155
		9,17	211	1,32	MR 4I 125 - 100 LA	4 153
		9	219	1,9	MR 3I 140 - 112 M	6 100
		8,4	235	2,65	MR 3I 160 - 112 M	6 107
		10,1	196	2,12	MR 3I 140 - 112 M	6 89,4
		10,8	179	0,8	MR 4I 100 - 90 LC	4 130
		11	176	1,6	MR 4I 125 - 90 LC	4 128
		11,2	173	1,6	MR 4I 125 - 100 LA	4 125
		12	165	1,5	MR 3I 125 - 112 M	6 75,3
		11,4	173	2	MR 3I 140 - 100 LA	4 123
14,1		137	1	MR 4I 100 - 90 LC	4 99,3	
15,5		127	0,95	MR 3I 100 - 90 LC	4 90,1	
15,6		127	0,85	MR 3I 100 - 112 M	6 57,7	
13,5		143	2	MR 4I 125 - 100 LA	4 104	
15,1		131	1,9	MR 3I 125 - 90 LC	4 92,9	
14,7		134	1,8	MR 3I 125 - 112 M	6 61,1	
14		141	3	MR 3I 140 - 100 LA	4 100	
15,7		126	3,35	MR 3I 140 - 100 LA	4 89,4	
16,9		114	1,25	MR 4I 100 - 90 LC	4 82,7	
18,5		106	1,12	MR 3I 100 - 90 LC	4 75,5	
19,1	103	1,06	MR 3I 100 - 90 LC	4 73,2		
19	104	1,18	MR 3I 100 - 112 M	6 47,4		
18,6	106	2,24	MR 3I 125 - 100 LA	4 75,3		
22,8	87	1,6	MR 3I 100 - 90 LC	4 61,5		
23,3	85	1,4	MR 3I 100 - 90 LC	4 60,2		
24,3	81	1,32	MR 3I 100 - 100 LA	4 57,7		

1) Leistungen bei Dauerbetrieb S1; bei Betriebsarten S2 ... S10 können sie gesteigert werden (s. Kap. 2b); M<sub>2</sub> steigt und f<sub>s</sub> fällt proportional.  
 2) Zur vollständigen Bestellbezeichnung s. Kap. 3.  
 \* Bauform B5R (s. Tabelle Kap. 2b).

1) Powers valid for continuous duty S1; increase possible for S2 ... S10 (see ch. 2b); in which case M<sub>2</sub> increases and f<sub>s</sub> decreases proportionately.  
 2) For complete designation when ordering see ch. 3.  
 \* Mounting position B5R (see table ch. 2b).





11 - Herstellungsprogramm (Stirnradgetriebemotoren)  
 11 - Manufacturing programmes (parallel shafts)

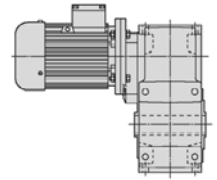

P <sub>1</sub> kW	n <sub>2</sub> min <sup>-1</sup>	M <sub>2</sub> daN m	f <sub>s</sub>	Getriebe - Motor Gear reducer - Motor	i
1)			2)		
4	11,2	315	0,9	MR 4I 125 - 112 M	4 125
	11,4	315	1,12	MR 3I 140 - 112 M	4 123
	11	327	1,6	MR 3I 160 - 112 M	4 128
	10,5	342	1,8	MR 3I 160 - 132 M	6 85,7
	10,7	337	2,24	MR 3I 180 - 112 M	4 131
	13,5	260	1,06	MR 4I 125 - 112 M	4 104
	15,1	238	1	MR 3I 125 - 112 M *	4 92,9
	14	256	1,6	MR 3I 140 - 112 M	4 100
	13,1	275	2,24	MR 3I 160 - 112 M	4 107
	15,7	229	1,9	MR 3I 140 - 112 M	4 89,4
	14,9	240	2,65	MR 3I 160 - 112 M	4 93,7
	18,6	193	1,25	MR 3I 125 - 112 M	4 75,3
	17,2	209	2	MR 3I 140 - 112 M	4 81,4
	19,2	187	2,24	MR 3I 140 - 112 M	4 72,8
	23,3	154	0,8	MR 3I 100 - 112 M *	4 60,2
	22,9	157	1,6	MR 3I 125 - 112 M	4 61,1
	22,6	159	2,65	MR 3I 140 - 112 M	4 62
	25,3	142	3	MR 3I 140 - 112 M	4 55,4
	28,6	126	1,12	MR 3I 100 - 112 M *	4 49
	29,5	122	1	MR 3I 100 - 112 M	4 47,4
	31,2	117	0,95	MR 2I 100 - 132 M	6 28,8
	28,6	125	2,24	MR 3I 125 - 112 M	4 48,9
	36,2	99	1,4	MR 3I 100 - 112 M	4 38,6
	37,9	97	1,25	MR 2I 100 - 132 M	6 23,7
	34,9	103	2,65	MR 3I 125 - 112 M	4 40,1
	37,4	98	2,5	MR 2I 125 - 132 M	6 24,1
	43,5	82	1,7	MR 3I 100 - 112 M	4 32,2
	48,6	76	1,4	MR 2I 100 - 112 M	4 28,8
	46,6	79	1,8	MR 2I 100 - 132 M	6 19,3
	42,3	85	3,35	MR 3I 125 - 112 M	4 33,1
	46,7	79	3,55	MR 2I 125 - 132 M	6 19,3
	53,8	68	0,85	MR 2I 80 - 112 M	4 26
	53,8	68	0,95	MR 2I 81 - 112 M	4 26
	56,9	63	2,24	MR 3I 100 - 112 M	4 24,6
	59	62	1,9	MR 2I 100 - 112 M	4 23,7
	58,1	63	3,75	MR 2I 125 - 112 M	4 24,1
	67,2	55	1,18	MR 2I 80 - 112 M	4 20,8
	67,2	55	1,4	MR 2I 81 - 112 M	4 20,8
	68,4	53	2,65	MR 3I 100 - 112 M	4 20,5
	72,5	51	2,65	MR 2I 100 - 112 M	4 19,3
89,4	41	1,6	MR 2I 80 - 112 M	4 15,7	
89,4	41	1,9	MR 2I 81 - 112 M	4 15,7	
87,1	42,1	3,15	MR 2I 100 - 112 M	4 16,1	
102	35,9	1,8	MR 2I 80 - 112 M	4 13,7	
102	35,9	2,12	MR 2I 81 - 112 M	4 13,7	
114	32,2	4,25	MR 2I 100 - 112 M	4 12,3	
136	27	2,36	MR 2I 80 - 112 M	4 10,3	
136	27	2,8	MR 2I 81 - 112 M	4 10,3	
137	26,8	5	MR 2I 100 - 112 M	4 10,2	
174	21	3,15	MR 2I 80 - 112 M	4 8,03	
218	16,8	3,35	MR 2I 80 - 112 M	4 6,41	
5,5	6,85	721	1,06	MR 3I 180 - 132 MB	6 131
	7,55	654	1,7	MR 3I 200 - 132 MB	6 119
	7,33	673	2,24	MR 3I 225 - 132 MB	6 123
	8,4	587	1,06	MR 3I 160 - 132 MB	6 107
	8,36	590	1,5	MR 3I 180 - 132 MB	6 108
	9	549	2,24	MR 3I 200 - 132 MB	6 100
	9,61	514	1,25	MR 3I 160 - 132 MB	6 93,7
	9,65	512	1,7	MR 3I 180 - 132 MB	6 93,3
	10,4	474	2,65	MR 3I 200 - 132 MB	6 86,4
	11,4	433	0,8	MR 3I 140 - 112 MC	4 123
	11,8	417	0,85	MR 3I 140 - 132 MB	6 76
	11	450	1,18	MR 3I 160 - 112 MC	4 128
	11	450	1,18	MR 3I 160 - 132 S	4 128
	10,5	470	1,32	MR 3I 160 - 132 MB	6 85,7
	10,7	463	1,6	MR 3I 180 - 112 MC	4 131
	10,7	463	1,6	MR 3I 180 - 132 S	4 131
	11,7	420	2,65	MR 3I 200 - 132 S	4 119
	13,5	357	0,8	MR 4I 125 - 112 MC	4 104
	14	353	1,18	MR 3I 140 - 112 MC	4 100

P <sub>1</sub> kW	n <sub>2</sub> min <sup>-1</sup>	M <sub>2</sub> daN m	f <sub>s</sub>	Getriebe - Motor Gear reducer - Motor	i
1)			2)		
5,5	14,5	340	1,18	MR 3I 140 - 132 MB	6 62
	13,1	378	1,6	MR 3I 160 - 112 MC	4 107
	13,1	378	1,6	MR 3I 160 - 132 S	4 107
	13	380	2,36	MR 3I 180 - 132 S	4 108
	15,7	315	1,32	MR 3I 140 - 112 MC	4 89,4
	16,3	304	1,4	MR 3I 140 - 132 MB	6 55,4
	14,9	330	1,9	MR 3I 160 - 112 MC	4 93,7
	14,9	330	1,9	MR 3I 160 - 132 S	4 93,7
	15	329	2,5	MR 3I 180 - 132 S	4 93,3
	16,5	294	0,95	MR 4I 125 - 112 MC	4 85,1
	18,6	266	0,9	MR 3I 125 - 112 MC	4 75,3
	18,4	268	0,9	MR 3I 125 - 132 MB	6 48,9
	17,2	287	1,4	MR 3I 140 - 112 MC	4 81,4
	18,4	268	1,32	MR 3I 140 - 132 S	4 76
	16,3	302	2	MR 3I 160 - 112 MC	4 85,7
	16,3	302	2	MR 3I 160 - 132 S	4 85,7
	16,3	304	2,8	MR 3I 180 - 132 S	4 86,1
	19,2	257	1,7	MR 3I 140 - 112 MC	4 72,8
	18,7	264	2,36	MR 3I 160 - 132 S	4 74,9
	22,9	215	1,12	MR 3I 125 - 112 MC	4 61,1
	23	215	1,32	MR 3I 125 - 132 MB	6 39,1
	22,6	218	1,9	MR 3I 140 - 112 MC	4 62
	22,6	218	1,9	MR 3I 140 - 132 S	4 62
	22,1	224	2,8	MR 3I 160 - 132 S	4 63,5
	25,3	195	2,12	MR 3I 140 - 132 S	4 55,4
	28,6	172	1,6	MR 3I 125 - 112 MC	4 48,9
	28,6	172	1,4	MR 3I 125 - 132 S	4 48,9
	28	176	1,6	MR 3I 125 - 132 MB	6 32,1
	27,8	178	2,36	MR 3I 140 - 132 S	4 50,4
	31,1	159	2,65	MR 3I 140 - 132 S	4 45,1
	36,2	136	1	MR 3I 100 - 112 MC	4 38,6
	37,9	133	0,9	MR 2I 100 - 132 MB	6 23,7
	34,9	142	2	MR 3I 125 - 112 MC	4 40,1
	35,8	138	2	MR 3I 125 - 132 S	4 39,1
	37,4	135	1,8	MR 2I 125 - 132 MB	6 24,1
	43,5	113	1,25	MR 3I 100 - 112 MC	4 32,2
	48,6	104	1	MR 2I 100 - 112 MC	4 28,8
	48,6	104	1	MR 2I 100 - 132 S	4 28,8
	46,6	108	1,32	MR 2I 100 - 132 MB	6 19,3
	43,6	113	2,5	MR 3I 125 - 132 S	4 32,1
	46,7	108	2,65	MR 2I 125 - 132 MB	6 19,3
	56,9	87	1,6	MR 3I 100 - 112 MC	4 24,6
	59	85	1,4	MR 2I 100 - 112 MC	4 23,7
	59	85	1,4	MR 2I 100 - 132 S	4 23,7
	52,8	94	3	MR 3I 125 - 132 S	4 26,5
	58,1	87	2,8	MR 2I 125 - 112 MC	4 24,1
	58,1	87	2,8	MR 2I 125 - 132 S	4 24,1
	67,2	75	0,9	MR 2I 80 - 112 MC	4 20,8
	67,2	75	1	MR 2I 81 - 112 MC	4 20,8
	68,4	72	1,9	MR 3I 100 - 112 MC	4 20,5
	72,5	70	2	MR 2I 100 - 112 MC	4 19,3
	72,5	70	2	MR 2I 100 - 132 S	4 19,3
	64,2	77	3,55	MR 3I 125 - 132 S	4 21,8
	72,6	69	4	MR 2I 125 - 132 S	4 19,3
	89,4	56	1,18	MR 2I 80 - 112 MC	4 15,7
	89,4	56	1,4	MR 2I 81 - 112 MC	4 15,7
	87,1	58	2,36	MR 2I 100 - 112 MC	4 16,1
	87,1	58	2,36	MR 2I 100 - 132 S	4 16,1
	102	49,3	1,32	MR 2I 80 - 112 MC	4 13,7
	102	49,3	1,5	MR 2I 81 - 112 MC	4 13,7
	114	44,3	3	MR 2I 100 - 112 MC	4 12,3
	114	44,3	3	MR 2I 100 - 132 S	4 12,3
	136	37,1	1,8	MR 2I 80 - 112 MC	4 10,3
	136	37,1	2,12	MR 2I 81 - 112 MC	4 10,3
	137	36,9	3,55	MR 2I 100 - 132 S	4 10,2
174	28,9	2,24	MR 2I 80 - 112 MC	4 8,03	
174	28,9	2,65	MR 2I 81 - 112 MC	4 8,03	
175	28,8	4,75	MR 2I 100 - 132 S	4 8,01	
218	23,1	2,5	MR 2I 80 - 112 MC	4 6,41	
218	23,1	2,8	MR 2I 81 - 112 MC	4 6,41	
218	23,1	5,3	MR 2I 100 - 132 S	4 6,42	
7,5	7,55	891	1,25	MR 3I 200 - 132 MC	6 119

1) Leistungen bei Dauerbetrieb S1; bei Betriebsarten S2 ... S10 können sie gesteigert werden (s. Kap. 2b); M<sub>2</sub> steigt und f<sub>s</sub> fällt proportional.  
 2) Zur vollständigen Bestellbezeichnung s. Kap. 3.  
 \* Bauform B5R (s. Tabelle Kap. 2b).

1) Powers valid for continuous duty S1; increase possible for S2 ... S10 (see ch. 2b); in which case M<sub>2</sub> increases and f<sub>s</sub> decreases proportionately.  
 2) For complete designation when ordering see ch. 3.  
 \* Mounting position B5R (see table ch. 2b).

















11 - Herstellungsprogramm (Stirnradgetriebmotoren)  
 11 - Manufacturing programmes (parallel shafts)

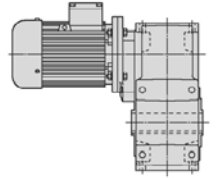

P <sub>1</sub> kW	n <sub>2</sub> min <sup>-1</sup>	M <sub>2</sub> daNm	f <sub>s</sub>	Getriebe - Motor Gear reducer - Motor	i	
1)				2)		
<b>110</b>	<b>63,2</b>	1596	2	MR 2I 280 - 315 S	4	22,2
	<b>61,3</b>	1646	2,5	MR 2I 320 - 315 S	4	22,8
	<b>71,1</b>	1419	1,7	MR 2I 250 - 315 S	4	19,7
	<b>69,8</b>	1446	2,36	MR 2I 280 - 315 S	4	20,1
	<b>78,7</b>	1282	2	MR 2I 250 - 315 S	4	17,8
	<b>78,1</b>	1292	2,65	MR 2I 280 - 315 S	4	17,9
	<b>86,5</b>	1165	2,12	MR 2I 250 - 315 S	4	16,2
	<b>89,2</b>	1130	2,8	MR 2I 280 - 315 S	4	15,7
	<b>95,7</b>	1053	1,5	MR 2I 225 - 315 S	4	14,6
	<b>95,9</b>	1051	2,12	MR 2I 250 - 315 S	4	14,6
	<b>95,2</b>	1059	3	MR 2I 280 - 315 S	4	14,7
	<b>110</b>	919	1,8	MR 2I 225 - 315 S	4	12,8
	<b>107</b>	941	2,5	MR 2I 250 - 315 S	4	13,1
	<b>105</b>	959	3,35	MR 2I 280 - 315 S	4	13,3
	<b>122</b>	828	2,12	MR 2I 225 - 315 S	4	11,5
	<b>119</b>	851	2,8	MR 2I 250 - 315 S	4	11,8
	<b>141</b>	717	2,36	MR 2I 225 - 315 S	4	9,95
<b>130</b>	773	3,15	MR 2I 250 - 315 S	4	10,7	
<b>158</b>	640	2,5	MR 2I 225 - 315 S	4	8,88	
<b>132</b>	<b>16,7</b>	7083	0,85	MR 3I 360 - 315 M	4	83,7
	<b>20,9</b>	5679	0,95	MR 3I 321 - 315 M	4	67,1
	<b>21,2</b>	5586	1,25	MR 3I 360 - 315 M	4	66
	<b>24,2</b>	4888	0,9	MR 3I 320 - 315 M	4	57,8
	<b>24,2</b>	4888	1,12	MR 3I 321 - 315 M	4	57,8
	<b>23,6</b>	5028	1,4	MR 3I 360 - 315 M	4	59,4
	<b>26,5</b>	4475	1	MR 3I 320 - 315 M	4	52,9
	<b>26,5</b>	4475	1,18	MR 3I 321 - 315 M	4	52,9
	<b>26,9</b>	4401	1,6	MR 3I 360 - 315 M	4	52
	<b>30,8</b>	3851	1,18	MR 3I 320 - 315 M	4	45,5
	<b>30,8</b>	3851	1,5	MR 3I 321 - 315 M	4	45,5
	<b>29,9</b>	3961	1,8	MR 3I 360 - 315 M	4	46,8
	<b>34,4</b>	3448	1,32	MR 3I 320 - 315 M	4	40,7
	<b>34,4</b>	3448	1,6	MR 3I 321 - 315 M	4	40,7
	<b>33,1</b>	3576	2	MR 3I 360 - 315 M	4	42,3
	<b>37,5</b>	3163	1,4	MR 3I 320 - 315 M	4	37,4
	<b>37,5</b>	3163	1,8	MR 3I 321 - 315 M	4	37,4
	<b>36,4</b>	3254	2,24	MR 3I 360 - 315 M	4	38,4
	<b>41,8</b>	2832	1,6	MR 3I 320 - 315 M	4	33,5
	<b>41,8</b>	2832	2	MR 3I 321 - 315 M	4	33,5
	<b>40,3</b>	2937	2,36	MR 3I 360 - 315 M	4	34,7
	<b>46,6</b>	2542	1,8	MR 3I 320 - 315 M	4	30
	<b>46,6</b>	2542	2,24	MR 3I 321 - 315 M	4	30
	<b>46,3</b>	2561	2,65	MR 3I 360 - 315 M	4	30,3
	<b>56</b>	2161	1	MR 2I 250 - 315 M	4	25
	<b>56,9</b>	2128	1,4	MR 2I 280 - 315 M	4	24,6
	<b>56</b>	2161	1,7	MR 2I 320 - 315 M	4	25
	<b>56</b>	2161	2	MR 2I 321 - 315 M	4	25
	<b>54,4</b>	2226	2,65	MR 2I 360 - 315 M	4	25,7
	<b>63,7</b>	1901	1,18	MR 2I 250 - 315 M	4	22
	<b>63,2</b>	1915	1,7	MR 2I 280 - 315 M	4	22,2
	<b>61,3</b>	1975	2	MR 2I 320 - 315 M	4	22,8
	<b>61,3</b>	1975	2,36	MR 2I 321 - 315 M	4	22,8
	<b>71,1</b>	1702	1,4	MR 2I 250 - 315 M	4	19,7
	<b>69,8</b>	1735	1,9	MR 2I 280 - 315 M	4	20,1
	<b>67,8</b>	1785	2,36	MR 2I 320 - 315 M	4	20,6
<b>78,7</b>	1539	1,6	MR 2I 250 - 315 M	4	17,8	

1) Leistungen bei Dauerbetrieb S1; bei Betriebsarten S2 ... S10 können sie **gesteigert** werden (s. Kap. 2b); M<sub>2</sub> steigt und f<sub>s</sub> fällt proportional.  
 2) Zur vollständigigen Bestellbezeichnung s. Kap. 3.

P <sub>1</sub> kW	n <sub>2</sub> min <sup>-1</sup>	M <sub>2</sub> daNm	f <sub>s</sub>	Getriebe - Motor Gear reducer - Motor	i	
1)				2)		
<b>132</b>	<b>78,1</b>	1550	2,24	MR 2I 280 - 315 M	4	17,9
	<b>78,8</b>	1536	2,8	MR 2I 320 - 315 M	4	17,8
	<b>86,5</b>	1398	1,8	MR 2I 250 - 315 M	4	16,2
	<b>89,2</b>	1356	2,36	MR 2I 280 - 315 M	4	15,7
	<b>88</b>	1375	3,15	MR 2I 320 - 315 M	4	15,9
	<b>95,9</b>	1261	1,8	MR 2I 250 - 315 M	4	14,6
	<b>95,2</b>	1271	2,5	MR 2I 280 - 315 M	4	14,7
	<b>107</b>	1129	2,12	MR 2I 250 - 315 M	4	13,1
	<b>105</b>	1151	2,8	MR 2I 280 - 315 M	4	13,3
	<b>119</b>	1021	2,36	MR 2I 250 - 315 M	4	11,8
	<b>118</b>	1029	3,35	MR 2I 280 - 315 M	4	11,9
	<b>130</b>	928	2,65	MR 2I 250 - 315 M	4	10,7
	<b>134</b>	900	3,75	MR 2I 280 - 315 M	4	10,4
	<b>152</b>	794	3,15	MR 2I 250 - 315 M	4	9,19
	<b>160</b>	<b>21,2</b>	6771	1	MR 3I 360 - 315 MC	4
<b>24,2</b>		5925	0,95	MR 3I 321 - 315 MC	4	57,8
<b>23,6</b>		6094	1,18	MR 3I 360 - 315 MC	4	59,4
<b>26,5</b>		5424	1	MR 3I 321 - 315 MC	4	52,9
<b>26,9</b>		5335	1,32	MR 3I 360 - 315 MC	4	52
<b>30,8</b>		4668	0,95	MR 3I 320 - 315 MC	4	45,5
<b>30,8</b>		4668	1,18	MR 3I 321 - 315 MC	4	45,5
<b>29,9</b>		4801	1,5	MR 3I 360 - 315 MC	4	46,8
<b>34,4</b>		4179	1,06	MR 3I 320 - 315 MC	4	40,7
<b>34,4</b>		4179	1,32	MR 3I 321 - 315 MC	4	40,7
<b>33,1</b>		4335	1,6	MR 3I 360 - 315 MC	4	42,3
<b>37,5</b>		3834	1,18	MR 3I 320 - 315 MC	4	37,4
<b>37,5</b>		3834	1,5	MR 3I 321 - 315 MC	4	37,4
<b>36,4</b>		3944	1,8	MR 3I 360 - 315 MC	4	38,4
<b>41,8</b>		3433	1,32	MR 3I 320 - 315 MC	4	33,5
<b>41,8</b>		3433	1,6	MR 3I 321 - 315 MC	4	33,5
<b>40,3</b>		3561	2	MR 3I 360 - 315 MC	4	34,7
<b>46,6</b>		3081	1,5	MR 3I 320 - 315 MC	4	30
<b>46,6</b>		3081	1,8	MR 3I 321 - 315 MC	4	30
<b>46,3</b>		3104	2,24	MR 3I 360 - 315 MC	4	30,3
<b>56,9</b>		2579	1,12	MR 2I 280 - 315 MC	4	24,6
<b>56</b>	2619	1,4	MR 2I 320 - 315 MC	4	25	
<b>56</b>	2619	1,7	MR 2I 321 - 315 MC	4	25	
<b>54,4</b>	2698	2,12	MR 2I 360 - 315 MC	4	25,7	
<b>63,2</b>	2321	1,4	MR 2I 280 - 315 MC	4	22,2	
<b>61,3</b>	2394	1,7	MR 2I 320 - 315 MC	4	22,8	
<b>61,3</b>	2394	2	MR 2I 321 - 315 MC	4	22,8	
<b>59,9</b>	2447	2,65	MR 2I 360 - 315 MC	4	23,4	
<b>69,8</b>	2103	1,6	MR 2I 280 - 315 MC	4	20,1	
<b>67,8</b>	2163	2	MR 2I 320 - 315 MC	4	20,6	
<b>67,8</b>	2163	2,36	MR 2I 321 - 315 MC	4	20,6	
<b>78,1</b>	1879	1,8	MR 2I 280 - 315 MC	4	17,9	
<b>78,8</b>	1862	2,36	MR 2I 320 - 315 MC	4	17,8	
<b>89,2</b>	1644	2	MR 2I 280 - 315 MC	4	15,7	
<b>88</b>	1667	2,65	MR 2I 320 - 315 MC	4	15,9	
<b>95,2</b>	1540	2	MR 2I 280 - 315 MC	4	14,7	
<b>105</b>	1395	2,36	MR 2I 280 - 315 MC	4	13,3	
<b>118</b>	1247	2,65	MR 2I 280 - 315 MC	4	11,9	
<b>134</b>	1091	3,15	MR 2I 280 - 315 MC	4	10,4	
<b>152</b>	966	3,35	MR 2I 280 - 315 MC	4	9,22	

1) Powers valid for continuous duty S1; **increase** possible for S2 ... S10 (see ch. 2b): in which case M<sub>2</sub> increases and f<sub>s</sub> decreases proportionately.  
 2) For complete designation when ordering see ch. 3.





## 12 - Herstellungsprogramm (Stirradgetriebemotoren für Fahrtrieb) / 12 - Manufacturing programme (parallel shafts for traverse movements)

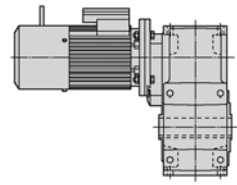

### 2.4 pol.

$P_1$ kW	$n_2$ min <sup>-1</sup>	$M_2$ daN m	$f_{s_{min}}$ bei / at $n_2$ min	Getriebe - Motor Gear reducer - Motor	$i$
3 2,2	37,2 - 18,6 45,8 - 22,9 48,6 - 24,3	72 - 106 59 - 86 55 - 81	2,24 2,8 1,32	MR 3I 125 - FVO 100LB 2.4 MR 3I 125 - FVO 100LB 2.4 MR 3I 100 - FVO 100LB 2.4	75,3 61,1 57,7
	57,3 - 28,6 59 - 29,5 69,8 - 34,9	47 - 69 45,6 - 67 38,6 - 57	>3 1,8 >3	MR 3I 125 - FVO 100LB 2.4 MR 3I 100 - FVO 100LB 2.4 MR 3I 125 - FVO 100LB 2.4	48,9 47,4 40,1
	72,5 - 36,2 87,1 - 43,5 97,1 - 48,6	37,2 - 54 30,9 - 45,4 28,3 - 41,5	2,5 >3 2,5	MR 3I 100 - FVO 100LB 2.4 MR 3I 100 - FVO 100LB 2.4 MR 2I 100 - FVO 100LB 2.4	38,6 32,2 28,8
	108 - 53,8 108 - 53,8 114 - 56,9	25,5 - 37,5 25,5 - 37,5 23,6 - 34,7	1,5 1,8 >3	MR 2I 80 - FVO 100LB 2.4 MR 2I 81 - FVO 100LB 2.4 MR 3I 100 - FVO 100LB 2.4	26 26 24,6

$P_1$ kW	$n_2$ min <sup>-1</sup>	$M_2$ daN m	$f_{s_{min}}$ bei / at $n_2$ min	Getriebe - Motor Gear reducer - Motor	$i$
3 2,2	118 - 59 134 - 67,2 134 - 67,2	23,3 - 34,2 20,5 - 30 20,5 - 30	>3 2,24 2,5	MR 2I 100 - FVO 100LB 2.4 MR 2I 80 - FVO 100LB 2.4 MR 2I 81 - FVO 100LB 2.4	23,7 20,8 20,8
	137 - 68,4 145 - 72,5 174 - 87,1	19,7 - 28,9 19 - 27,8 15,8 - 23,2	>3 >3 >3	MR 3I 100 - FVO 100LB 2.4 MR 2I 100 - FVO 100LB 2.4 MR 2I 100 - FVO 100LB 2.4	20,5 19,3 16,1
	179 - 89,4 205 - 102 228 - 114	15,4 - 22,6 13,4 - 19,7 12,1 - 17,7	3 >3 >3	MR 2I 80 - FVO 100LB 2.4 MR 2I 80 - FVO 100LB 2.4 MR 2I 100 - FVO 100LB 2.4	15,7 13,7 12,3
	272 - 136 349 - 174 436 - 218	10,1 - 14,8 7,9 - 11,6 6,3 - 9,2	>3 >3 >3	MR 2I 80 - FVO 100LB 2.4 MR 2I 80 - FVO 100LB 2.4 MR 2I 80 - FVO 100LB 2.4	10,3 8,03 6,41

### 2.6 pol.

$P_1$ kW	$n_2$ min <sup>-1</sup>	$M_2$ daN m	$f_{s_{min}}$ bei / at $n_2$ min	Getriebe - Motor Gear reducer - Motor	$i$
0,18 0,065	22,4 - 7,19 27,1 - 8,71 33 - 10,6	7,1 - 7,9 5,8 - 6,6 4,8 - 5,4	>3 >3 >3	MR 4I 63 - FVO 71A 2.6 MR 4I 63 - FVO 71A 2.6 MR 4I 63 - FVO 71A 2.6	125 103 84,9
4)	45,8 - 14,7 60,6 - 19,5 73,7 - 23,7	3,53- 3,96 2,67- 2,99 2,19- 2,46	>3 >3 >3	MR 3I 63 - FVO 71A 2.6 MR 3I 50 - FVO 71A 2.6 MR 3I 50 - FVO 71A 2.6	61,1 46,2 38
	90,5 - 29,1 115 - 36,9 120 - 38,7	1,79- 2,01 1,44- 1,62 1,34- 1,51	>3 >3 >3	MR 3I 50 - FVO 71A 2.6 MR 2I 50 - FVO 71A 2.6 MR 3I 50 - FVO 71A 2.6	30,9 24,4 23,3
	139 - 44,8 145 - 46,5	1,18- 1,33 1,12- 1,26	>3 >3	MR 2I 50 - FVO 71A 2.6 MR 3I 50 - FVO 71A 2.6	20,1 19,4
0,25 0,095	22,4 - 7,19 27,1 - 8,71 33 - 10,6	9,8 - 11,6 8,1 - 9,6 6,7 - 7,9	2,65 >3 >3	MR 4I 63 - FVO 71B 2.6 MR 4I 63 - FVO 71B 2.6 MR 4I 63 - FVO 71B 2.6	125 103 84,9
4)	45,8 - 14,7 57,3 - 18,4 60,6 - 19,5	4,9 - 5,8 3,92- 4,63 3,7 - 4,38	>3 >3 3	MR 3I 63 - FVO 71B 2.6 MR 3I 63 - FVO 71B 2.6 MR 3I 50 - FVO 71B 2.6	61,1 48,9 46,2
	69,8 - 22,4 73,7 - 23,7 90,5 - 29,1	3,22- 3,8 3,05- 3,6 2,48- 2,93	>3 >3 >3	MR 3I 63 - FVO 71B 2.6 MR 3I 50 - FVO 71B 2.6 MR 3I 50 - FVO 71B 2.6	40,1 38 30,9
	115 - 36,9 120 - 38,7 139 - 44,8	2 - 2,36 1,86- 2,2 1,64- 1,94	>3 >3 >3	MR 2I 50 - FVO 71B 2.6 MR 3I 50 - FVO 71B 2.6 MR 2I 50 - FVO 71B 2.6	24,4 23,3 20,1
	145 - 46,5 171 - 55,1 228 - 73,2	1,55- 1,84 1,34- 1,58 1,01- 1,19	>3 >3 >3	MR 3I 50 - FVO 71B 2.6 MR 2I 50 - FVO 71B 2.6 MR 2I 50 - FVO 71B 2.6	19,4 16,3 12,3
0,37 0,14	20,2 - 6,49 21,4 - 6,89 22,1 - 7,11	16,1 - 18,9 15,2 - 17,9 14,7 - 17,3	>3 2,24 >3	MR 4I 80 - FVO 71C 2.6 MR 4I 64 - FVO 71C 2.6 MR 4I 80 - FVO 80A 2.6	139 131 127
4)	22,4 - 7,19 25,3 - 8,14 26 - 8,36	14,5 - 17,1 12,8 - 15,1 12,5 - 14,7	1,8 >3 2,65	MR 4I 63 - FVO 71C 2.6 MR 4I 80 - FVO 80A 2.6 MR 4I 64 - FVO 71C 2.6	125 111 108
	27,1 - 8,71 33 - 10,6 33,7 - 10,8	12 - 14,1 9,9 - 11,6 9,7 - 11,4	2,24 2,65 >3	MR 4I 63 - FVO 71C 2.6 MR 4I 63 - FVO 71C 2.6 MR 4I 80 - FVO 80A 2.6	103 84,9 83,2
	42,4 - 13,6 45,8 - 14,7 57,2 - 18,4	7,8 - 9,2 7,2 - 8,5 5,8 - 6,8	>3 >3 >3	MR 3I 80 - FVO 80A 2.6 MR 3I 63 - FVO 71C 2.6 MR 3I 63 - FVO 80A 2.6	66 61,1 48,9
	57,3 - 18,4 60,6 - 19,5 71,6 - 23	5,8 - 6,8 5,5 - 6,5 4,64- 5,5	>3 2 >3	MR 3I 63 - FVO 71C 2.6 MR 3I 50 - FVO 71C 2.6 MR 3I 63 - FVO 80A 2.6	48,9 46,2 39,1
	73,7 - 23,7 87,1 - 28 90,5 - 29,1	4,51- 5,3 3,81- 4,49 3,67- 4,32	2,8 >3 >3	MR 3I 50 - FVO 71C 2.6 MR 3I 63 - FVO 80A 2.6 MR 3I 50 - FVO 71C 2.6	38 32,1 30,9
	106 - 33,9 115 - 36,9	3,15- 3,7 2,96- 3,48	>3 >3	MR 3I 63 - FVO 80A 2.6 MR 2I 50 - FVO 71C 2.6	26,5 24,4

$P_1$ kW	$n_2$ min <sup>-1</sup>	$M_2$ daN m	$f_{s_{min}}$ bei / at $n_2$ min	Getriebe - Motor Gear reducer - Motor	$i$
0,37 0,14	116 - 37,4 120 - 38,7 128 - 41,3 139 - 44,8	2,92- 3,44 2,76- 3,25 2,59- 3,04 2,43- 2,86	>3 >3 >3 >3	MR 2I 63 - FVO 80A 2.6 MR 3I 50 - FVO 71C 2.6 MR 3I 63 - FVO 80A 2.6 MR 2I 50 - FVO 71C 2.6	24,1 23,3 21,8 20,1
4)	145 - 46,5 145 - 46,7 171 - 55,1	2,3 - 2,71 2,33- 2,75 1,98- 2,33	>3 >3 >3	MR 3I 50 - FVO 71C 2.6 MR 2I 63 - FVO 80A 2.6 MR 2I 50 - FVO 71C 2.6	19,4 19,3 16,3
	177 - 56,8 214 - 68,9 228 - 73,2	1,92- 2,26 1,58- 1,86 1,49- 1,75	>3 >3 >3	MR 2I 63 - FVO 80A 2.6 MR 2I 63 - FVO 80A 2.6 MR 2I 50 - FVO 71C 2.6	15,8 13,1 12,3
	261 - 83,9 274 - 87,9	1,3 - 1,53 1,24- 1,46	>3 >3	MR 2I 63 - FVO 80A 2.6 MR 2I 50 - FVO 71C 2.6	10,7 10,2
0,55 0,21	22,1 - 7,11 25,3 - 8,14 33,7 - 10,8	21,8 - 25,9 19,1 - 22,7 14,4 - 17	2,65 3 >3	MR 4I 80 - FVO 80B 2.6 MR 4I 80 - FVO 80B 2.6 MR 4I 80 - FVO 80B 2.6	127 111 83,2
4)	42,4 - 13,6 52,9 - 17 57,2 - 18,4	11,6 - 13,8 9,3 - 11,1 8,6 - 10,2	>3 >3 2,65	MR 3I 80 - FVO 80B 2.6 MR 3I 80 - FVO 80B 2.6 MR 3I 63 - FVO 80B 2.6	66 52,9 48,9
	71,6 - 23 87,1 - 28 106 - 33,9	6,9 - 8,2 5,7 - 6,7 4,68- 5,6	>3 >3 >3	MR 3I 63 - FVO 80B 2.6 MR 3I 63 - FVO 80B 2.6 MR 3I 63 - FVO 80B 2.6	39,1 32,1 26,5
	115 - 36,9 116 - 37,4 128 - 41,3	4,39- 5,2 4,34- 5,2 3,84- 4,56	2,5 >3 >3	MR 2I 50 - FVO 80B 2.6 MR 2I 63 - FVO 80B 2.6 MR 3I 63 - FVO 80B 2.6	24,4 24,1 21,8
	139 - 44,8 145 - 46,7 171 - 55,1	3,62- 4,29 3,47- 4,12 2,94- 3,5	>3 >3 >3	MR 2I 50 - FVO 80B 2.6 MR 2I 63 - FVO 80B 2.6 MR 2I 50 - FVO 80B 2.6	20,1 19,3 16,3
	177 - 56,8 214 - 68,9 228 - 73,2	2,85- 3,39 2,35- 2,8 2,21- 2,63	>3 >3 >3	MR 2I 63 - FVO 80B 2.6 MR 2I 63 - FVO 80B 2.6 MR 2I 50 - FVO 80B 2.6	15,8 13,1 12,3
	261 - 83,9 274 - 87,9 339 - 109	1,93- 2,3 1,84- 2,19 1,49- 1,77	>3 >3 >3	MR 2I 63 - FVO 80B 2.6 MR 2I 50 - FVO 80B 2.6 MR 2I 63 - FVO 80B 2.6	10,7 10,2 8,26
	350 - 112 429 - 138 436 - 140	1,44- 1,71 1,18- 1,4 1,16- 1,37	>3 >3 >3	MR 2I 50 - FVO 80B 2.6 MR 2I 63 - FVO 80B 2.6 MR 2I 50 - FVO 80B 2.6	8,01 6,53 6,42
0,75 0,3	21,6 - 6,93 22,1 - 7,11 22,1 - 7,11	30,6 - 38 29,8 - 37,1 29,8 - 37,1	>3 1,8 2,12	MR 4I 100 - FVO 90S 2.6 MR 4I 80 - FVO 80C 2.6 MR 4I 81 - FVO 80C 2.6	130 127 127
4)	22,5 - 7,23 25,3 - 8,14 25,3 - 8,14	29,3 - 36,4 26 - 32,4 26 - 32,4	>3 2,12 2,36	MR 4I 100 - FVO 80C 2.6 MR 4I 80 - FVO 80C 2.6 MR 4I 81 - FVO 80C 2.6	124 111 111
	27 - 8,69 28,2 - 9,06 33,7 - 10,8 33,9 - 10,9	24,4 - 30,3 23,4 - 29,1 19,6 - 24,4 19,5 - 24,2	>3 >3 2,8 >3	MR 4I 100 - FVO 80C 2.6 MR 4I 100 - FVO 90S 2.6 MR 4I 80 - FVO 80C 2.6 MR 4I 100 - FVO 90S 2.6	104 99,3 83,2 82,7

- 1) Leistungen bei Dauerbetrieb S1; bei Betriebsarten S2... S10 können sie gesteigert werden (s. Kap. 2b);  $M_2$  steigt und  $f_s$  fällt proportional; bitte rückfragen.  
2) Zur vollständigen Bestellbezeichnung s. Kap. 3. Auch FO-Ausführung «Normalbremsmotor» vorgesehen.  
3) Leistungen bei Dauerbetrieb S1; bei Betriebsarten S3 60 und 40% können die Leistungen bis 18% gesteigert werden;  $M_2$  steigt und  $f_s$  fällt proportional; bitte rückfragen.  
4) Auch Getriebegröße 40 zur Verfügung; bitte rückfragen.  
Bei der Bestimmung des Betriebsfaktors  $b$  oder  $c$  als Belastung annehmen (Kap. 5).

- 1) Powers valid for continuous duty S1; increase possible for S2 ... S10 (see ch. 2b): in which case  $M_2$  increases and  $f_s$  decreases proportionately; consult us.  
2) For complete designation when ordering see ch. 3. «Normal brake motor» design FO also possible.  
3) Powers valid for continuous duty S1; 18% increase possible for S3 duty 60 and 40% in which case  $M_2$  increases and  $f_s$  decreases proportionately; consult us.  
4) Gear reducer size 40 also available; consult us.  
When determining service factor, assume nature of load  $b$  or  $c$  (ch. 5).













12 - Herstellungsprogramm (Stirnradgetriebemotoren für Fahrtriebe)  
 12 - Manufacturing programme (parallel shafts for traverse movements)

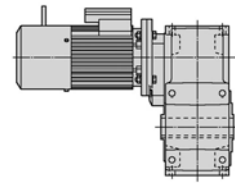

2.12 pol.

$P_1$ kW 3)	$n_2$ min <sup>-1</sup>	$M_2$ daN m	$f_{s, \min}$ bei / at $n_2$ max	Getriebe - Motor Gear reducer - Motor 2)	$i$
2,2 0,33	32,9 - 5,29	59 - 55	> 3	MR 4I 125 - FV0 112MA 2.12	85,1
	37,2 - 5,98	53 - 49,6	> 3	MR 3I 125 - FV0 112MA 2.12	75,3
	45,8 - 7,37	43,1 - 40,2	> 3	MR 3I 125 - FV0 112MA 2.12	61,1
	48,6 - 7,8	40,7 - 38	2,65	MR 3I 100 - FV0 112MA 2.12	57,7
	59 - 9,49	33,5 - 31,2	> 3	MR 3I 100 - FV0 112MA 2.12	47,4
	72,5 - 11,6	27,2 - 25,4	> 3	MR 3I 100 - FV0 112MA 2.12	38,6
	87,1 - 14	22,7 - 21,2	> 3	MR 3I 100 - FV0 112MA 2.12	32,2
	97,1 - 15,6	20,8 - 19,4	> 3	MR 2I 100 - FV0 112MA 2.12	28,8
	108 - 17,3	18,7 - 17,5	3	MR 2I 80 - FV0 112MA 2.12	26
	114 - 18,3	17,3 - 16,2	> 3	MR 3I 100 - FV0 112MA 2.12	24,6
	118 - 19	17,1 - 15,9	> 3	MR 2I 100 - FV0 112MA 2.12	23,7
	134 - 21,6	15 - 14	> 3	MR 2I 80 - FV0 112MA 2.12	20,8
	137 - 22	14,4 - 13,5	> 3	MR 3I 100 - FV0 112MA 2.12	20,5
	145 - 23,3	13,9 - 13	> 3	MR 2I 100 - FV0 112MA 2.12	19,3
	174 - 28	11,6 - 10,8	> 3	MR 2I 100 - FV0 112MA 2.12	16,1
	179 - 28,7	11,3 - 10,5	> 3	MR 2I 80 - FV0 112MA 2.12	15,7
	205 - 32,9	9,9 - 9,2	> 3	MR 2I 80 - FV0 112MA 2.12	13,7
	228 - 36,6	8,9 - 8,3	> 3	MR 2I 100 - FV0 112MA 2.12	12,3
	272 - 43,7	7,4 - 6,9	> 3	MR 2I 80 - FV0 112MA 2.12	10,3
	274 - 44	7,4 - 6,9	> 3	MR 2I 100 - FV0 112MA 2.12	10,2
349 - 56	5,8 - 5,4	> 3	MR 2I 80 - FV0 112MA 2.12	8,03	
350 - 56,2	5,8 - 5,4	> 3	MR 2I 100 - FV0 112MA 2.12	8,01	
436 - 70,1	4,62 - 4,31	> 3	MR 2I 80 - FV0 112MA 2.12	6,41	
3 0,42	22,3 - 3,59	118 - 103	2,36	MR 4I 125 - FV0 112MB 2.12	125
	27 - 4,35	97 - 85	2,8	MR 4I 125 - FV0 112MB 2.12	104

- 2) Zur vollständigen Bestellbezeichnung s. Kap. 3. Auch **F0**-Ausführung «Normalbremsmotor» vorgesehen.  
 3) Leistungen bei Dauerbetrieb S1; bei Betriebsarten **S3 60** und **40%** können die Leistungen bis **18% gesteigert** werden:  $M_2$  steigt und  $f_s$  fällt proportional, bitte rückfragen. Bei der Bestimmung des Betriebsfaktors **b** oder **c** als Belastung annehmen (Kap. 5).

$P_1$ kW 3)	$n_2$ min <sup>-1</sup>	$M_2$ daN m	$f_{s, \min}$ bei / at $n_2$ max	Getriebe - Motor Gear reducer - Motor 2)	$i$
3 0,42	32,9 - 5,29	80 - 70	> 3	MR 4I 125 - FV0 112MB 2.12	85,1
	37,2 - 5,98	72 - 63	> 3	MR 3I 125 - FV0 112MB 2.12	75,3
	45,8 - 7,37	59 - 51	> 3	MR 3I 125 - FV0 112MB 2.12	61,1
	48,6 - 7,8	55 - 48,3	1,9	MR 3I 100 - FV0 112MB 2.12	57,7
	57,3 - 9,21	47 - 40,9	> 3	MR 3I 125 - FV0 112MB 2.12	48,9
	59 - 9,49	45,6 - 39,7	2,65	MR 3I 100 - FV0 112MB 2.12	47,4
	72,5 - 11,6	37,2 - 32,4	> 3	MR 3I 100 - FV0 112MB 2.12	38,6
	87,1 - 14	30,9 - 26,9	> 3	MR 3I 100 - FV0 112MB 2.12	32,2
	97,1 - 15,6	28,3 - 24,7	> 3	MR 2I 100 - FV0 112MB 2.12	28,8
	108 - 17,3	25,5 - 22,2	2,24	MR 2I 80 - FV0 112MB 2.12	26
	108 - 17,3	25,5 - 22,2	2,5	MR 2I 81 - FV0 112MB 2.12	26
	114 - 18,3	23,6 - 20,6	> 3	MR 3I 100 - FV0 112MB 2.12	24,6
	118 - 19	23,3 - 20,3	> 3	MR 2I 100 - FV0 112MB 2.12	23,7
	134 - 21,6	20,5 - 17,8	> 3	MR 2I 80 - FV0 112MB 2.12	20,8
	137 - 22	19,7 - 17,2	> 3	MR 3I 100 - FV0 112MB 2.12	20,5
	145 - 23,3	19 - 16,5	> 3	MR 2I 100 - FV0 112MB 2.12	19,3
	174 - 28	15,8 - 13,8	> 3	MR 2I 100 - FV0 112MB 2.12	16,1
	179 - 28,7	15,4 - 13,4	> 3	MR 2I 80 - FV0 112MB 2.12	15,7
	205 - 32,9	13,4 - 11,7	> 3	MR 2I 80 - FV0 112MB 2.12	13,7
	228 - 36,6	12,1 - 10,5	> 3	MR 2I 100 - FV0 112MB 2.12	12,3
272 - 43,7	10,1 - 8,8	> 3	MR 2I 80 - FV0 112MB 2.12	10,3	
274 - 44	10,1 - 8,8	> 3	MR 2I 100 - FV0 112MB 2.12	10,2	
349 - 56	7,9 - 6,9	> 3	MR 2I 80 - FV0 112MB 2.12	8,03	
350 - 56,2	7,9 - 6,9	> 3	MR 2I 100 - FV0 112MB 2.12	8,01	
436 - 70,1	6,3 - 5,5	> 3	MR 2I 80 - FV0 112MB 2.12	6,41	

- 2) For complete designation when ordering see ch. 3. «Normal brake motor» design **F0** also possible.  
 3) Powers valid for continuous duty S1; **18% increase** possible for **S3 duty 60** and **40%** in which case  $M_2$  increases and  $f_s$  decreases proportionately; consult us. When determining service factor, assume nature of load **b** or **c** (ch. 5).

# 13 - Bauarten, Abmessungen, Bauformen und Ölmengen

# 13 - Designs, dimensions, mounting positions and oil quantities

MR 2I 40 ... 125

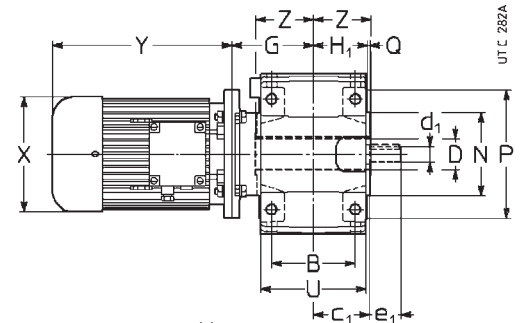
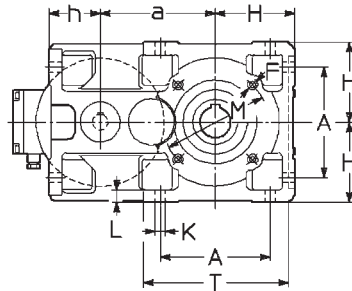

**Bauart**<sup>1)</sup> (Drehsinn)  
**Design**<sup>1)</sup> (direction of rotation)

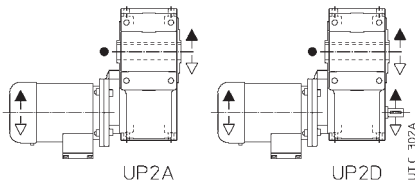

- Position der Bezugsrille (s. Kap. 20) zur Ermittlung der Radialbelastung.
- Position of the reference groove (see ch. 20) for verification of radial load.

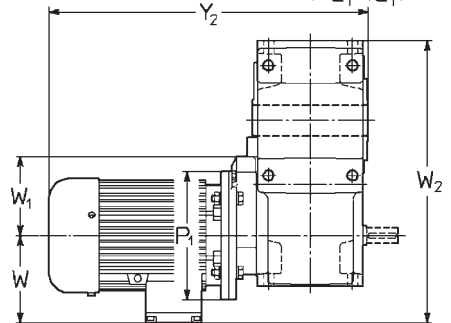

Größe Size	a	A	B	c <sub>1</sub>	D Ø H7	d <sub>1</sub> Ø	e <sub>1</sub>	F	G	H h11	H <sub>1</sub> h11	h Ø	K Ø	L Ø	M Ø	N Ø h6	P Ø	Q	T	U	Z	P <sub>1</sub> Ø	X Ø	Y ≈	Y <sub>2</sub> ≈	W ≈	W <sub>1</sub> ≈	W <sub>2</sub> ≈	Masse Mass kg			
Getr. red. Motor motor <b>B5</b>							2)																	3)					3)			
<b>40</b> 63 71 <sup>7)</sup>	73,5	73	65	43	19	11	23	M5	69,5	56	41,5	40,5	7	10	75	60	90	2,5	102	80	46	140 140	122 140	185 225	229 288	301 341	345 404	101 112	56 56	231 242	11 14	13 17
<b>50</b> 63 71 80 <sup>7)</sup>	90	86	75	51	24	14	30	M6	77 79	67	49	50	9,5	12	85	70	105	2,5	120	95	53	140 160 160	122 140 160	185 211 245	229 275 325	315 343 377	359 407 457	101 112 122	70 80 80	258 269 279	15 18 21	17 21 26
<b>63</b> <b>64</b> 71 80 *90 100 <sup>6)</sup>	113 (63) 115 (64)	102	90	61	30 (63) 32 (64)	16	30	M8	90	80	58,5	62	11,5	14	100	80	120	3	143	114	63	160 200 200	140 160 200	211 231 270	275 307 355	364 384 423	428 460 508	112 122 149	80 100 100	307 317 344	23 27 33	26 32 38
<b>80</b> <b>81</b> 90 100 <sup>6)</sup> *112 <sup>5)</sup>	142,5	132	106	72	38 (80) 40 (81)	19	40	M10	108	100	69,5	70	14	17	130	110	160	3,5	180	135	75	200 250 250	180 207 207	270 343 343	355 419 445	453 526 526	538 602 628	149 164 164	100 125 125	392 407 407	45 52 62	50 59 73
<b>100</b> 90 100 112 *132 <sup>5)</sup>	180	172	131	87	48	24	50	M12	130 150	125	84,5	80	16	20	165	130	200	3,5	228	165	90	200 250 250 300	180 207 207 260	270 343 343 402	355 419 445 537	490 563 563 642	575 639 665 777	149 164 164 196	125 125 125 150	454 469 469 501	66 73 83 113	71 80 94 129
<b>125</b> 112 132 *160 *180	225	212	162	107	60	28	60	4)	159 164 179	150	103,5	100	18	23	215	180	250	4	274	201	110	250 300 350	207 260 315	343 402 540	445 537 634	612 676 829	714 811 923	164 196 235	166 166 175	539 571 610	117 147 180	128 163 204

- 1) Bez. Motorbauart s. Kap. 3.
  - 2) Nutzlänge des Gewindes 2 · F.
  - 3) Werte gelten für Bremsmotor.
  - 4) Abmessung, Zahl und Winkelposition s. Kap. 20.
  - 5) Auf Anfrage für 100LB 4, 112M 4 und 132M 4 auch Bauform **B5R** zur Verfügung (s. Kap. 2b).
  - 6) Bauform **B5R**, Bremsmotor nicht möglich.
  - 7) Bauform **B5A** (s. Kap. 2b), Bremsmotoren **F0 71D 4** und **F0 80D 4** nicht möglich.
- \* **WICHTIG:** bei **Bremsmotor** (außer **F0 90S** und **F0 90L**; Größen **180L** auch **Normalausführung**) und Aufsteckbefestigung oder Bauformen B3, B8, **unbedingt rückfragen**. Bremsmotor **F0 180** nicht möglich

- 1) For motor design see ch. 3.
  - 2) Working length of thread 2 · F.
  - 3) Values valid for brake motor.
  - 4) For dimension, number and angular position see ch. 20.
  - 5) On request for 100LB 4, 112M 4 and 132M 4 also available mounting position **B5R** (see ch. 2b).
  - 6) Mounting position **B5R**, brake motor not possible.
  - 7) Mounting position **B5A** (see ch. 2b), brake motors **F0 71D 4** and **F0 80D 4** not possible.
- \* **IMPORTANT:** in the event of a **brake motor** (**F0 90S** and **F0 90L** excluded; size **180L** even with **standard** motor) and shaft mounting or mounting positions B3, B8, **we must be consulted**. Brake motor **F0 180L** not possible.

## Bauformen und Ölmengen [l]

## Mounting positions and oil quantities [l]

Größe Size	B3, B8	B6, B7, V5, V6
<b>40</b>	0,4	0,55
<b>50</b>	0,6	0,8
<b>63, 64</b>	0,9	1,2
<b>80, 81</b>	1,5	2,3
<b>100</b>	2,9	4,5
<b>125</b>	5,6	8

Falls nicht anders angegeben, werden die Getriebemotoren in der normalen Bauform **B3** geliefert, die als solche **nicht** in der Bezeichnung aufzutreten braucht.

Unless otherwise stated, gearmotors are supplied in mounting position **B3** which, being standard, is **omitted** from the designation.

13 - Bauarten, Abmessungen, Bauformen und Ölmengen

13 - Designs, dimensions, mounting positions and oil quantities

MR 31 40 ... 125

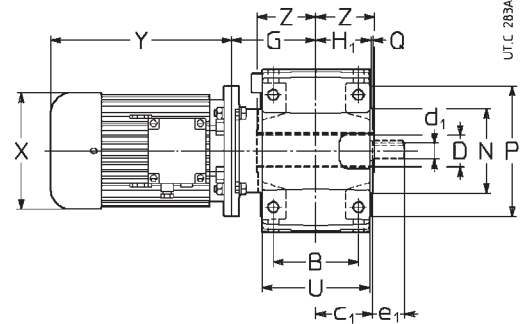
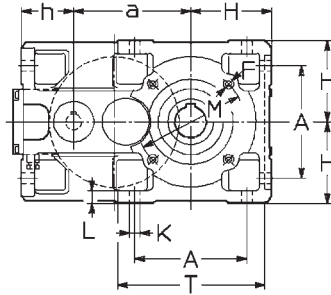
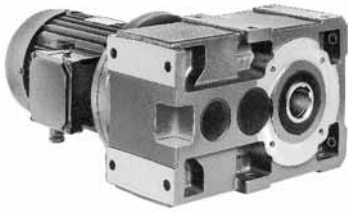

Bauart<sup>1)</sup> (Drehsinn)  
Design<sup>1)</sup> (direction of rotation)

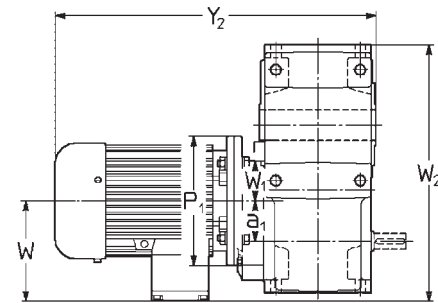
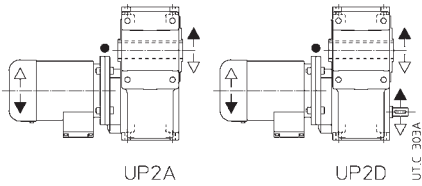

- Position der Bezugsrille (s. Kap. 20) zur Ermittlung der Radialbelastung.
- Position of the reference groove (see ch. 20) for verification of radial load.

Größe Size	a	A	B	c <sub>1</sub>	D Ø H7	d <sub>1</sub> Ø	e <sub>1</sub>	F	G	H	H <sub>1</sub>	h	K Ø	L	M Ø	N Ø h6	P Ø	Q	T	U	Z	P <sub>1</sub> Ø	X Ø ≈	Y ≈	Y <sub>2</sub> ≈	W ≈	W <sub>1</sub> ≈	W <sub>2</sub> ≈	Masse Mass kg				
Getr. red.	Motor motor																																
B5	a <sub>1</sub>																																
40	63	73,5 30	73	65	43	19	11	23	M5	69,5	56	41,5	40,5	7	10	75	60	90	2,5	102	80	46	140	122	185	229	301	345	101	26	201	13	15
50	63 71	90 32	86	75	51	24	14	30	M6	77 79	67	49	50	9,5	12	85	70	105	2,5	120	95	53	140 160	122 140	185 211	229 275	315 343	359 407	101 112	35	226 237	18 22	20 25
63 64	63 71 80 90 <sup>5)</sup>	113 (63) 115 (64) 40	102	90	61	30 (63) 32 (64)	16	30	M8	90	80	58,5	62	11,5	14	100	80	120	3	143	114	63	140 160 200 200	122 140 211 275	185 211 275 307	229 338 382	315 364 428	359 407 460	101 112 122	40	257 267 277	23 27 31	25 30 36
80 81	71 80 90 100 <sup>5)</sup>	142,5 50	132	106	72	38 (80) 40 (81)	19	40	M10	108	100	69,5	70	14	17	130	110	160	3,5	180	135	75	160 200 200 200	140 160 211 275	211 231 307 355	275 315 414 490	394 458 538	458 538	112 122	50	313 315 342 357	35 39 45 54	38 44 50 61
100	80 90 100 112	180 63	172	131	87	48	24	50	M12	130	125	84,5	80	16	20	165	130	200	3,5	228	165	90	200 200 250 250	160 180 207 207	231 270 343 343	307 355 419 445	451 490 563 563	527 575 639	122 149	62	385 392 407 407	61 67 74 84	66 72 81 95
125	90 100 112 132	225 80	212	162	107	60	28	60	4)	159	150	103,5	100	18	23	215	180	250	4	274	201	110	200 250 250 300	180 207 207 260	270 343 419 445	355 419 612 676	539 624 688	624 714	149 164 164	86	475 475 475 491	108 115 125 155	113 122 136 171

- 1) Bez. Motorbauart s. Kap. 3.
- 2) Nutzlänge des Gewindes 2 · F.
- 3) Werte gelten für Bremsmotor.
- 4) Abmessung, Zahl und Winkelposition s. Kap. 20.
- 5) Bauform B5R.

- 1) For motor design see ch. 3.
- 2) Working length of thread 2 · F.
- 3) Values valid for brake motor.
- 4) For dimension, number and angular position see ch. 20.
- 5) Mounting position B5R.

Bauformen und Ölmengen [l]

Mounting positions and oil quantities [l]

B3	B6	B7	B8	V5	V6	Größe Size	B3, B8	B6	B7, V5 <sup>1)</sup> , V6
						40	0,47	0,55	0,55
						50	0,7	1,05	0,9
						63, 64	1	1,5	1,3
						80, 81	1,7	2,9	2,5
						100	3,3	5,7	4,9
						125	6,1	10,2	8,8

Falls nicht anders angegeben, werden die Getriebemotoren in der normalen Bauform B3 geliefert, die als solche nicht in der Bezeichnung aufzutreten braucht.  
1) Die ersten 2 Übersetzungsstufen sind mit Fett «lebensdauer geschmiert» (Menge 5% i.V. mit Öl).

Unless otherwise stated, gearmotors are supplied in mounting position B3 which, being standard, is omitted from the designation.  
1) First reduction stage lubricated «for life» with grease (5% oil quantity).

MR 4I 63 ... 125

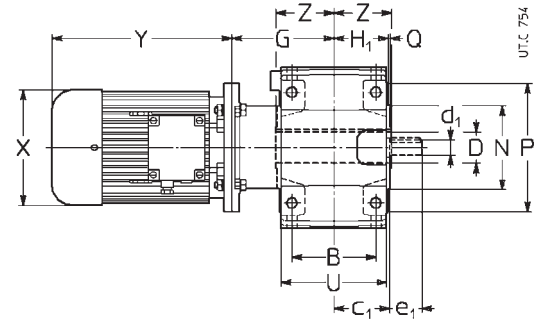
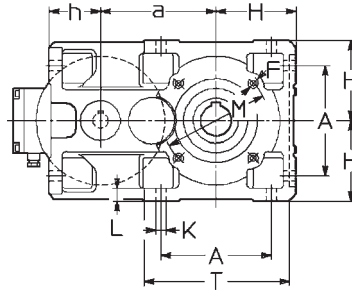

**Bauart**<sup>1)</sup> (Drehsinn)  
**Design**<sup>1)</sup> (direction of rotation)

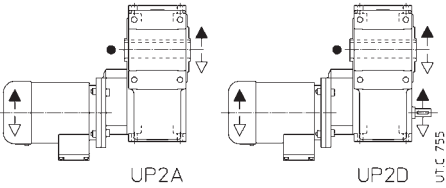

- Position der Bezugsrille (s. Kap. 20) zur Ermittlung der Radialbelastung.
- Position of the reference groove (see ch. 20) for verification of radial load.

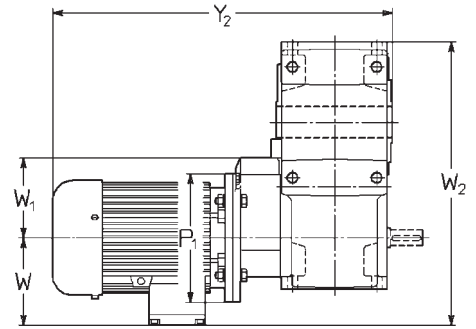

Größe Size	a	A	B	c <sub>1</sub>	D Ø H7	d <sub>1</sub> Ø	e <sub>1</sub>	F	G	H	H <sub>1</sub>	h h11	K Ø	L	M Ø	N Ø h6	P Ø	Q	T	U	Z	P <sub>1</sub> Ø	X Ø	Y ≈	Y <sub>2</sub> ≈	W ≈	W <sub>1</sub>	W <sub>2</sub>	Masse Mass kg				
63 64	63 71	113 (63) 115 (64)	102	90	61	30 (63) 32 (64)	16	30	M8	109	80	58,5	62	11,5	14	100	80	120	3	143	114	63	140 160	122 140	185 211	229 275	357 383	401 447	101 112	80	296 307	23 27	25 30
80 81	71 80	142,5	132	106	72	38 (80) 40 (81)	19	40	M10	135	100	69,5	70	14	17	130	110	160	3,5	180	135	75	160 200	140 160	211 231	275 307	421 441	485 517	112 122	100	355 365	36 40	39 45
100	80 90	180	172	131	87	48	24	50	M12	163	125	84,5	80	16	20	165	130	200	3,5	228	165	90	200 250	160 207	231 343	307 419	484 656	560 732	122 164	125 149	427 454	63 69	68 74
125	90 100 112	225	212	162	107	60	28	60	4)	203	150	103,5	100	18	23	215	180	250	4	274	201	110	200 250	180 207	270 343	355 419	583 656	668 732	149 164	166 199	524 539	111 118	116 125

- 1) Bez. Motorbauart s. Kap. 3.
- 2) Nutzlänge des Gewindes 2 · F.
- 3) Werte gelten für Bremsmotor.
- 4) Abmessung, Zahl und Winkelposition s. Kap. 20.

- 1) For motor design see ch. 3.
- 2) Working length of thread 2 · F.
- 3) Values valid for brake motor.
- 4) For dimension, number and angular position see ch. 20.

Bauformen und Ölmengen [l]

Mounting positions and oil quantities [l]

Größe Size	B3, B8	B6	B7, V6	V5 <sup>1)</sup>
63, 64	1,1	1,8	1,4	1,3
80, 81	1,9	3,2	2,7	2,5
100	3,6	6	5,3	4,9
125	6,6	10,7	9,4	8,8

Falls nicht anders angegeben, werden die Getriebemotoren in der normalen Bauform **B3** geliefert, die als solche **nicht** in der Bezeichnung aufzutreten braucht.  
1) Die ersten 2 Übersetzungsstufen sind mit Fett «lebensdauergergeschmiert» (Menge 10% i.V. mit Öl).

Unless otherwise stated, gearmotors are supplied in mounting position **B3** which, being standard, is **omitted** from the designation.  
1) The first 2 reduction stages lubricated «for life» with grease (10% oil quantity).



# 13 - Bauarten, Abmessungen, Bauformen und Ölmengen

Anmerkungen von Seite 86.

- 1) Bez. Motorbauart s. Kap. 3.
- 2) Nutzlänge des Gewindes 2 · F.
- 3) Werte gelten für Bremsmotor.
- 4) Bauform **B5R** (s. Kap. 2b), Bremsmotor nicht möglich.
- 5) Bei **3I** Bauform **B5R** (s. Kap. 2b), Bremsmotor nicht möglich. Bei Größe **315S** werden folgende Werte reduziert: Maß **X**: auf Ø 490, Maß **Y** auf 820, Maß **W** auf 360, Masse auf 1102 kg.
- 6) Abmessung, Zahl und Winkelposition s. Kap. 20.

\* **WICHTIG:** Bei **Bremsmotor** (Größen **280M** und **315M Normalausführung**) und Aufsteckbefestigung oder Bauformen B3, B8, **unbedingt rückfragen**. Bremsmotor **F0 180L** ist für Größe **140** nicht möglich.

## Bauformen und Ölmengen [I]

B3		B6		B7		B8		V5		V6		Größe Size	B3	B8		B6, B7, V5, V6
2I	3I	2I	3I	2I	3I	2I	3I	2I	3I	2I	3I			2I	3I	
$i_n \leq 14 \geq 200$	$i_n \geq 16 \geq 320$	$i_n \leq 14 \geq 160$	$i_n \geq 16 \geq 250$	$i_n \leq 14 \geq 160$	$i_n \geq 16 \geq 250$	$i_n \leq 14 \geq 200$	$i_n \geq 16 \geq 320$	$i_n \leq 14 \geq 200$	$i_n \geq 16 \geq 320$	$i_n \leq 63 \geq 250$		140	6	6	9,5	9,5
												160	10	10	16	16
												180	10,6	10,6	17	17
												200	19	19	30	30
												225	20	20	32	32
												250	36	36	56	56
												280	38	38	60	60
												320, 321	67	67	106	106
												360	71	71	112	112

Falls nicht anders angegeben, werden die Getriebemotoren in der normalen Bauform **B3** geliefert, die als solche **nicht** in der Bezeichnung aufzutreten braucht.

☑ ggf. hohe Ölspritzleistung: Die Nennwärmeleistung  $P_{tn}$  (Kap. 4) ist mit **0,85** (B6 und V6), **0,71** (B7 und V5) zu multiplizieren;

⚙ ggf. Lagerschmierpumpe: Bei Bedarf bitte rückfragen.

# 13 - Designs, dimensions, mounting positions and oil quantities

Notes of page 86.

- 1) For motor design see ch. 3.
- 2) Working length of thread 2 · F.
- 3) Values valid for brake motor.
- 4) Mounting position **B5R** (see ch. 2b), brake motor not possible.
- 5) For **3I** mounting position **B5R** (see ch. 2b), brake motor not possible. For size **315S** also following values are reduced: dimension **X**: Ø 490, dimension **Y**: Ø 820, dimension **W**: 360, mass: 1102 kg.
- 6) For dimension, number and angular position see ch. 20.

\* **IMPORTANT:** in the event of a **brake motor** (sizes **280M** and **315M** with **standard motor**) and shaft mounting or mounting position B3, B8, **we must be consulted**. Brake motor **F0 180L** is not possible for gear reducer size **140**.

## Mounting positions and oil quantities [I]

Unless otherwise stated, gear reducers are supplied in mounting position **B3** which, being standard, is **omitted** from the designation.

☑ possible high oil-splash: nominal thermal power  $P_{tn}$  (ch. 4) is to be multiplied by **0,85** (B6 and V6), **0,71** (B7 and V5);

⚙ possible bearings lubrication pump: consult us if need be.

**Langes Modell - Long model**  
**MR 2I 100, 125**

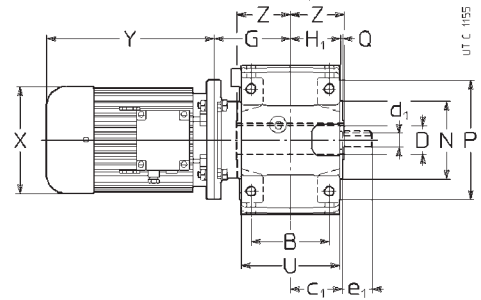
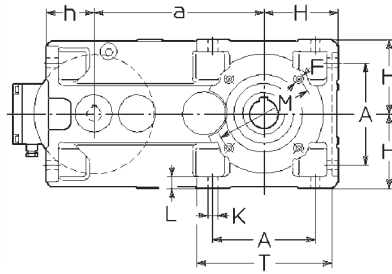

**Bauart<sup>1)</sup> (Drehsinn)**  
**Design<sup>1)</sup> (direction of rotation)**

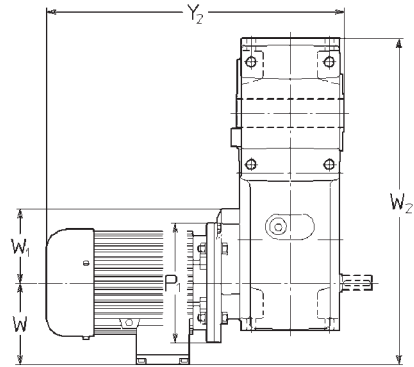
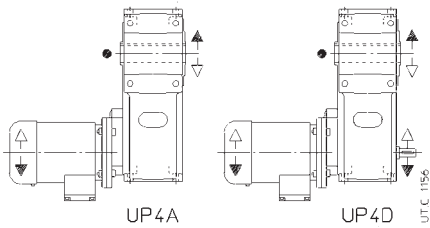

- Position der Bezugsrille (s. Kap. 20) zur Ermittlung der Radialbelastung.
- Position of the reference groove (see ch. 20) for verification of radial load.

Größe Size	a	A	B	c <sub>1</sub>	D Ø H7	d <sub>1</sub> Ø	e <sub>1</sub>	F	G	H	H <sub>1</sub>	h	K	L	M	N	P	Q	T	U	Z	P <sub>1</sub> Ø	X Ø ≈	Y ≈	Y <sub>2</sub> ≈	W ≈	W <sub>1</sub> ≈	W <sub>2</sub> ≈	Masse Mass kg				
Getriebe gear red.																																	
Motor motor <b>B5</b>								2)																3)	3)				3)				
<b>100</b>	<b>90</b>	284,7	172	131	87	48	24	50	M12	130	125	84,5	80,3	16	20	165	130	200	3,5	228	165	90	200	180	270	355	490	575	149	125	559	75	80
	<b>100</b>																					250	207	343	419	563	639	164	125	574	82	89	
	<b>112</b>																					250	207	343	445	563	665	164	125	574	92	103	
	<b>*132<sup>5)</sup></b>									150												300	260	402	537	642	777	196	150	606	122	138	
<b>125</b>	<b>112</b>	358	212	162	107	60	28	60	4)	159	150	103,5	100	18	23	215	180	250	4	274	201	110	250	207	343	445	612	714	164	166	672	133	144
	<b>132</b>									164												300	260	402	537	676	811	196	166	704	163	179	
	<b>*160</b>									179												350	315	540	634	829	923	235	175	743	196	220	
	<b>*180</b>																					350	354	615	—	904	—	257	175	765	250	—	

1) Bez. Motorbauart s. Kap. 3.  
 2) Nutzlänge des Gewindes 2 · F.  
 3) Werte gelten für Bremsmotor.  
 4) Abmessung, Zahl und Winkelposition s. Kap. 20.  
 5) Auf Anfrage für 100LB 4, 112M 4 und 132M 4 auch Bauform **B5R** (s. Kap. 2b).  
 \* **WICHTIG:** Bei **Bremsmotor** (Größe **180L** auch **Normalausführung**) und Aufsteckbefestigung oder Bauformen B3, B8, **unbedingt rückfragen**. Bremsmotor **F0 180L** nicht möglich.

1) For motor design see ch. 3.  
 2) Working length of thread 2 · F.  
 3) Values valid for brake motor.  
 4) For dimension, number and angular position see ch. 20.  
 5) On request for 100LB 4, 112M 4 and 132M 4 also available mounting position **B5R** (see ch. 2b).  
 \* **IMPORTANT:** in the event of a **brake motor** (size **180L** even with **standard** motor) and shaft mounting or mounting positions B3, B8, **we must be consulted**. Brake motor **F0 180L** not possible.

**Bauformen und Ölmengen [l]**

**Mounting positions and oil quantities [l]**

Größe Size	B3, B8	B6, B7	V5, V6
<b>100</b>	3,9	7,1	6,1
<b>125</b>	7,8	13	11

Falls nicht anders angegeben, werden die Getriebemotoren in der normalen Bauform **B3** geliefert, die als solche **nicht** in der Bezeichnung aufzutreten braucht.

Unless otherwise stated, gearmotors are supplied in mounting position **B3** which, being standard, is **omitted** from the designation.



**Langes Modell - Long model**  
**MR 3I 100, 125**

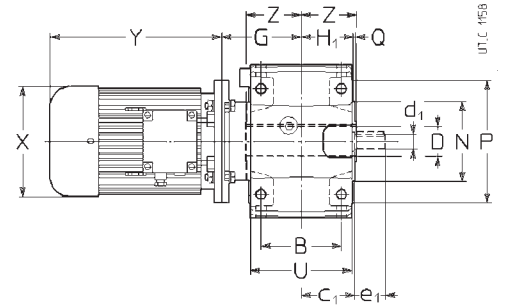
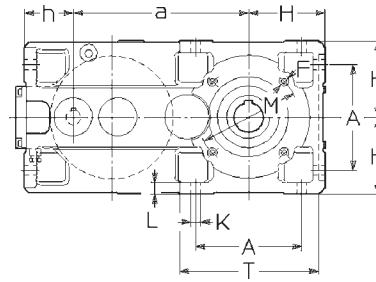
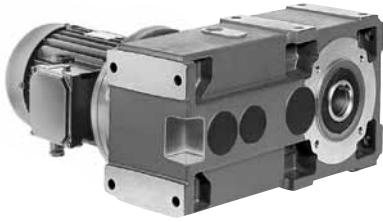

**Bauart<sup>1)</sup> (Drehsinn)**  
**Design<sup>1)</sup> (direction of rotation)**

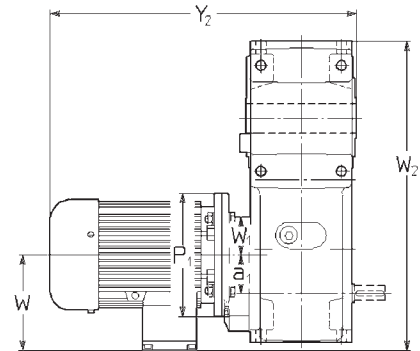
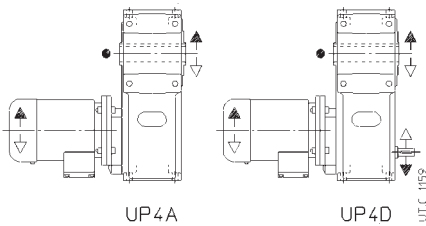

- Position der Bezugsrille (s. Kap. 20) zur Ermittlung der Radialbelastung.
- Position of the reference groove (see ch. 20) for verification of radial load.

Größe Size	a	A	B	c <sub>1</sub>	D Ø H7	d <sub>1</sub> Ø	e <sub>1</sub>	F	G	H	H <sub>1</sub>	h h11	K Ø	L	M Ø	N Ø h6	P Ø	Q	T	U	Z	P <sub>1</sub> Ø	X Ø	Y ≈	Y <sub>2</sub> ≈	W ≈	W <sub>1</sub> ≈	W <sub>2</sub> ≈	Masse Mass kg				
																														Getriebe gear red.	Motor motor	B5	a <sub>1</sub>
100	80	284,7	172	131	87	48	24	50	M12	130	125	84,5	80,3	16	20	165	130	200	3,5	228	165	90	200	160	231	307	451	527	122	62	490	70	75
	90	63																					200	180	270	355	490	575	149	496	76	81	
	100																						250	207	343	419	563	639	164	511	83	90	
	112																						250	207	343	445	563	665	164	511	93	104	
125	90	358	212	162	107	60	28	60	4)	159	150	103,5	100	18	23	215	180	250	4	274	201	110	200	180	270	355	539	624	149	86	608	124	129
	100	80																					250	207	343	419	612	688	164	608	131	138	
	112																						250	207	343	445	612	714	164	608	141	152	
	132									164													300	260	402	537	676	811	196	624	171	187	

- 1) Bez. Motorbauart s. Kap. 3.
- 2) Nutzlänge des Gewindes 2 · F.
- 3) Werte gelten für Bremsmotor.
- 4) Abmessung, Zahl und Winkelposition s. Kap. 20.

- 1) For motor design see ch. 3.
- 2) Working length of thread 2 · F.
- 3) Values valid for brake motor.
- 4) For dimension, number and angular position see ch. 20.

**Bauformen und Ölmengen [l]**

**Mounting positions and oil quantities [l]**

Größe Size	B3, B8	B6, B7	V5, V6
100	4,3	8,3	6,5
125	8,3	16	12

Falls nicht anders angegeben, werden die Getriebemotoren in der normalen Bauform **B3** geliefert, die als solche **nicht** in der Bezeichnung aufzutreten braucht.

Unless otherwise stated, gearmotors are supplied in mounting position **B3** which, being standard, is **omitted** from the designation.

**Langes Modell - Long model**  
**MR 2I, 3I 140 .. 225**

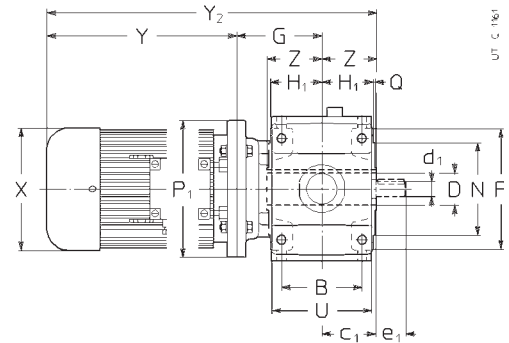
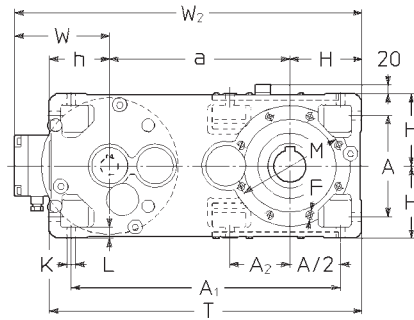

**Bauart<sup>1)</sup> (Drehsinn)**

**Design<sup>1)</sup> (direction of rotation)**

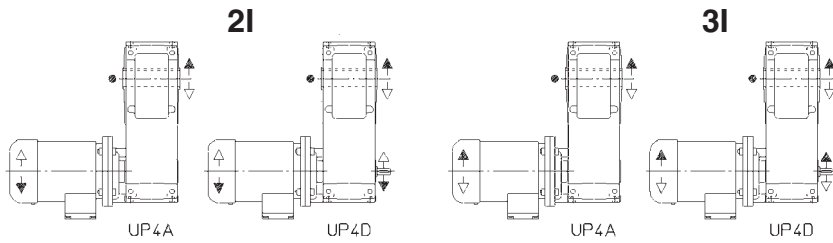

● Position der Bezugsrille (s. Kap. 20) zur Ermittlung der Radialbelastung.

● Position of the reference groove (see ch. 20) for verification of radial load.

Größe Size		a	A	A <sub>1</sub>	A <sub>2</sub>	B	c	D Ø H7	d Ø	e	d <sub>1</sub> Ø	e <sub>1</sub>	F	G	H	H <sub>1</sub>	h	K	L	M	N Ø h6	P Ø	T	Z	P <sub>1</sub> Ø	X Ø	Y ≈	Y <sub>2</sub> ≈	W ≈	W <sub>2</sub> ≈	Masse Mass kg			
Getriebe gear red. 6)	Motor motor B5																																	
											2I	3I	2)																					
140	100	373	212	560	127	162	107	70	28	60	24	50	6)	134	150	103,5	125	18	23	265	230	300	648	125	250	207	343	419	602	678	164	687	155	162
	112																				230	4	201	125	250	207	343	445	602	704	164	687	165	176
	132																				230	4	201	125	300	260	402	537	686	821	196	719	195	211
	*160 <sup>5)</sup>																								350	315	540	634	844	938	235	758	228	252
160	100	450	252	672	—	201	132	80	38	80	28	60	M16	179	180	128,5	150	22	28	265	230	300	780	136	250	207	343	445	658	734	164	794	235	242
	112																				230	4	249	136	250	207	343	445	658	760	164	794	245	256
	132																				230	4	249	136	300	260	402	537	717	852	196	826	275	291
	160														204										350	315	540	634	880	974	235	865	308	332
180	112	470	252	692	170	201	132	90	38	80	28	60	M16	179	180	128,5	150	22	28	300	250	350	800	150	250	207	343	445	672	774	164	814	263	274
	132																				250	5	249	150	300	260	402	537	731	866	196	846	293	309
	160														204										350	315	540	634	894	988	235	885	326	350
	*180														194										350	354	615	734	955	1 074	257	887	362	398
200	132	556	320	831	—	250	162	100	48	110	38	80	6)	225	225	158	180	27	34	350	300	400	961	167	300	260	402	537	794	929	196	977	428	444
	160																				300	5	307	167	350	315	540	634	932	1 026	235	1016	461	485
	180																								350	354	615	734	1 007	1 126	257	1 038	515	551
	200														255										400	354	615	734	1 007	1 126	257	1 038	541	581
225	132	581	320	856	223	250	162	110	48	110	38	80	M20	225	225	158	180	27	34	400	350	450	986	180	300	260	402	537	807	942	196	1 002	460	476
	160																				350	5	307	180	350	315	540	634	945	1 039	235	1 041	493	517
	180																								350	354	615	734	1 020	1 139	257	1 063	547	583
	200														255										400	354	615	734	1 020	1 139	257	1 063	573	613
225	225																								450	416	690	—	1 125	—	292	1 098	633	—
	250 <sup>3)</sup>																								550	416	690	—	1 125	—	292	1 098	667	—
280	280																								550	490	820	—	1 255	—	360	1 166	830	—
	315 <sup>1)</sup>																								550	490	820	—	1 255	—	360	1 166	858	—

1) Bez. Motorbauart s. Kap. 3.  
 2) Nutzlänge des Gewindes 2 · F.  
 3) Werte gelten für Bremsmotor.  
 4) Bauform **B5R** (s. Kap. 2b), Bremsmotor nicht möglich.  
 5) Bei **3I** Bauform **B5R** (s. Kap. 2b), Bremsmotor nicht möglich. Bei Größe **315S** werden folgende Werte reduziert: Maß **X**: auf Ø 490, Maß **Y** auf 820, Maß **W** auf 360, Masse auf 1102 kg.  
 6) Masse, Nummer und Winkellage s. Kap. 20.  
 \* **WICHTIG**: Bei **Bremsmotor** (Größen **280M** und **315M Normalausführung**) und Aufsteckbefestigung oder Bauformen B3, B8, **unbedingt rückfragen**.

1) For motor design see ch. 3.  
 2) Working length of thread 2 · F.  
 3) Values valid for brake motor.  
 4) Mounting position **B5R** (see ch. 2b), brake motor not possible.  
 5) For **3I** mounting position **B5R** (see ch. 2b), brake motor not possible. For size **315S** also following values are reduced: dimension **X**: Ø 490, dimension **Y**: **X** 820, dimension **W**: 360, mass: 1102 kg.  
 6) For dimensions, number and angular position see ch. 20.  
 \* **IMPORTANT**: in the event of a **brake motor** (sizes **280M** and **315M** with **standard motor**) and shaft mounting or mounting position B3, B8, **we must be consulted**.

13 - Bauarten, Abmessungen, Bauformen und Ölmengen

13 - Designs, dimensions, mounting positions and oil quantities

**Bauformen und Ölmengen [1]**

**Mounting positions and oil quantities [1]**

	B3	B8		B6, B7	V5, V6
		2l	3l		
Größe Size					
140	8,2	8,2	12	15	13
160	14	14	20	26	22
180	15	15	21	27	23
200	27	27	38	49	42
225	28	28	40	51	44

Falls nicht anders angegeben, werden die Getriebemotoren in der normalen Bauform **B3** geliefert, die als solche **nicht** in der Bezeichnung aufzutreten braucht.

ψ ggf. hohe Ölspritzleistung: Die Nennwärmeleistung  $P_{tN}$  (Kap. 4) ist mit **0,85** (B6 und V6), **0,71** (B7 und V5) zu multiplizieren;

⊕ ggf. Lagerschmierpumpe: Bei Bedarf bitte rückfragen.

Unless otherwise stated, gear reducers are supplied in mounting position **B3** which, being standard, is **omitted** from the designation.

possible high oil-splash: nominal thermal power  $P_{tN}$  (ch. 4) is to be multiplied by **0,85** (B6 and V6), **0,71** (B7 and V5);

possible bearings lubrication pump: consult us if need be.

# 14 - Herstellungsprogramm (Kegelstirnradgetriebemotoren)

## 14 - Manufacturing programme (right angle shafts)

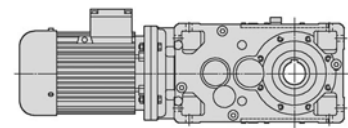
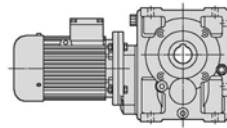

P <sub>1</sub> kW 1)	n <sub>2</sub> min <sup>-1</sup>	M <sub>2</sub> daN m	f <sub>s</sub>	Getriebe - Motor Gear reducer - Motor 2)	i
<b>0,09</b>	<b>4,28</b>	18,5	0,8	MR C3I 50 - 63 A 6	210
	<b>5,25</b>	15,1	1,12	MR C3I 50 - 63 A 6	171
	<b>6,66</b>	11,9	1,4	MR C3I 50 - 63 A 6	135
	<b>10,7</b>	7,6	1,9	MR ICI 50 - 63 A 6	84,3
	<b>11,9</b>	6,8	1,06	MR ICI 40 - 63 A 6	75,8
	<b>13,3</b>	6,1	2,36	MR ICI 50 - 63 A 6	67,5
	<b>14,4</b>	5,6	1,18	MR ICI 40 - 63 A 6	62,5
	<b>16,4</b>	4,93	3,35	MR ICI 50 - 63 A 6	54,9
	<b>18,8</b>	4,29	1,7	MR ICI 40 - 63 A 6	47,8
	<b>22,8</b>	3,54	2,24	MR ICI 40 - 63 A 6	39,4
	<b>29,5</b>	2,74	2,5	MR ICI 40 - 63 A 6	30,5
	<b>34,4</b>	2,4	2,5	MR CI 40 - 63 A 6	26,2
	<b>41,5</b>	1,99	3,55	MR CI 40 - 63 A 6	21,7
	<b>50,4</b>	1,64	4	MR CI 40 - 63 A 6	17,9
	<b>65,9</b>	1,25	5,3	MR CI 40 - 63 A 6	13,7
	<b>79,9</b>	1,03	7,1	MR CI 40 - 63 A 6	11,3
<b>0,12</b>	<b>5,25</b>	20,1	0,8	MR C3I 50 - 63 B 6	171
	<b>6,65</b>	15,8	0,9	MR C3I 50 - 63 A 4	210
	<b>6,66</b>	15,8	1,06	MR C3I 50 - 63 B 6	135
	<b>8,17</b>	12,9	1,25	MR C3I 50 - 63 A 4	171
	<b>10,4</b>	10,2	1,6	MR C3I 50 - 63 A 4	135
	<b>10,7</b>	10,1	1,4	MR ICI 50 - 63 B 6	84,3
	<b>11,9</b>	9,1	0,8	MR ICI 40 - 63 B 6	75,8
	<b>13,3</b>	8,1	1,8	MR ICI 50 - 63 B 6	67,5
	<b>14,4</b>	7,5	0,9	MR ICI 40 - 63 B 6	62,5
	<b>16,6</b>	6,5	2,24	MR ICI 50 - 63 A 4	84,3
	<b>18,5</b>	5,8	1,18	MR ICI 40 - 63 A 4	75,8
	<b>18,8</b>	5,7	1,25	MR ICI 40 - 63 B 6	47,8
	<b>20,8</b>	5,2	2,8	MR ICI 50 - 63 A 4	67,5
	<b>22,4</b>	4,81	1,4	MR ICI 40 - 63 A 4	62,5
	<b>22,8</b>	4,72	1,7	MR ICI 40 - 63 B 6	39,4
	<b>25,5</b>	4,23	4	MR ICI 50 - 63 A 4	54,9
	<b>29,3</b>	3,68	1,9	MR ICI 40 - 63 A 4	47,8
	<b>34,4</b>	3,2	1,9	MR CI 40 - 63 B 6	26,2
	<b>35,5</b>	3,03	2,65	MR ICI 40 - 63 A 4	39,4
	<b>41,5</b>	2,65	2,65	MR CI 40 - 63 B 6	21,7
	<b>45,9</b>	2,35	2,8	MR ICI 40 - 63 A 4	30,5
	<b>53,5</b>	2,06	3	MR CI 40 - 63 A 4	26,2
	<b>64,6</b>	1,7	4	MR CI 40 - 63 A 4	21,7
	<b>78,4</b>	1,4	4,5	MR CI 40 - 63 A 4	17,9
	<b>102</b>	1,07	6,3	MR CI 40 - 63 A 4	13,7
	<b>124</b>	0,89	8	MR CI 40 - 63 A 4	11,3
	<b>161</b>	0,69	9,5	MR CI 40 - 63 A 4	8,72
	<b>0,18</b>	<b>2,29</b>	69	0,8	MR C3I 81 - 71 A 6
<b>2,74</b>		58	0,9	MR C3I 80 - 71 A 6	329
<b>2,74</b>		58	0,95	MR C3I 81 - 71 A 6	329
<b>3,42</b>		46,3	1,25	MR C3I 80 - 71 A 6	263
<b>3,42</b>		46,3	1,4	MR C3I 81 - 71 A 6	263
<b>4,44</b>		35,6	0,95	MR C3I 64 - 71 A 6	202
<b>4,27</b>		37	1,6	MR C3I 80 - 71 A 6	211
<b>4,27</b>		37	1,8	MR C3I 81 - 71 A 6	211
<b>5,56</b>		28,5	1,06	MR C3I 63 - 71 A 6	162
<b>5,56</b>		28,5	1,18	MR C3I 64 - 71 A 6	162
<b>5,33</b>		29,6	2,12	MR C3I 80 - 71 A 6	169
<b>7,05</b>		22,4	1,4	MR C3I 63 - 71 A 6	128
<b>7,05</b>		22,4	1,7	MR C3I 64 - 71 A 6	128
<b>7,58</b>		21,3	1,06	MR ICI 63 - 71 A 6	119
<b>7,58</b>		21,3	1,32	MR ICI 64 - 71 A 6	119
<b>7,29</b>		22,2	2,24	MR ICI 80 - 71 A 6	124

P <sub>1</sub> kW 1)	n <sub>2</sub> min <sup>-1</sup>	M <sub>2</sub> daN m	f <sub>s</sub>	Getriebe - Motor Gear reducer - Motor 2)	i
<b>0,18</b>	<b>8,17</b>	19,4	0,85	MR C3I 50 - 63 B 4	171
	<b>9,19</b>	17,2	0,95	MR C3I 50 - 71 A 6	97,9
	<b>9,47</b>	17,1	1,6	MR ICI 63 - 71 A 6	95
	<b>9,47</b>	17,1	2	MR ICI 64 - 71 A 6	95
	<b>9,11</b>	17,7	3,35	MR ICI 80 - 71 A 6	98,8
	<b>10,4</b>	15,3	1,06	MR C3I 50 - 63 B 4	135
	<b>11,3</b>	14,3	1,9	MR ICI 63 - 71 A 6	79,5
	<b>14,7</b>	11	1,32	MR ICI 50 - 71 A 6	61,1
	<b>14,1</b>	11,4	2,36	MR ICI 63 - 71 A 6	63,6
	<b>16,6</b>	9,7	1,5	MR ICI 50 - 63 B 4	84,3
	<b>17,7</b>	9,1	3,15	MR ICI 63 - 71 A 6	50,9
	<b>18,5</b>	8,8	0,8	MR ICI 40 - 63 B 4	75,8
	<b>19,9</b>	8,1	0,85	MR ICI 40 - 71 A 6	45,3
	<b>20,8</b>	7,8	1,9	MR ICI 50 - 63 B 4	67,5
	<b>22,4</b>	7,2	0,95	MR ICI 40 - 63 B 4	62,5
	<b>26</b>	6,2	1,12	MR ICI 40 - 71 A 6	34,7
	<b>25,5</b>	6,3	2,65	MR ICI 50 - 63 B 4	54,9
	<b>28,8</b>	5,7	3,75	MR CI 63 - 71 A 6	31,3
	<b>29,3</b>	5,5	1,25	MR ICI 40 - 63 B 4	47,8
	<b>31,5</b>	5,1	1,5	MR ICI 40 - 71 A 6	28,6
	<b>34,4</b>	4,8	1,25	MR CI 40 - 71 A 6	26,2
	<b>32,3</b>	5	3,35	MR ICI 50 - 63 B 4	43,3
	<b>37,4</b>	4,42	3,15	MR CI 50 - 71 A 6	24,1
	<b>35,5</b>	4,55	1,7	MR ICI 40 - 63 B 4	39,4
	<b>40,7</b>	3,97	1,7	MR ICI 40 - 71 A 6	22,1
	<b>41,5</b>	3,97	1,7	MR CI 40 - 71 A 6	21,7
	<b>45,9</b>	3,52	1,9	MR ICI 40 - 63 B 4	30,5
	<b>53,5</b>	3,09	1,9	MR CI 40 - 63 B 4	26,2
	<b>64,6</b>	2,55	2,65	MR CI 40 - 63 B 4	21,7
	<b>78,4</b>	2,1	3,15	MR CI 40 - 63 B 4	17,9
<b>102</b>	1,61	4	MR CI 40 - 63 B 4	13,7	
<b>124</b>	1,33	5,6	MR CI 40 - 63 B 4	11,3	
<b>161</b>	1,03	6,3	MR CI 40 - 63 B 4	8,72	
<b>0,25</b>	<b>3,56</b>	62	0,85	MR C3I 80 - 71 A 4	393
	<b>3,56</b>	62	0,9	MR C3I 81 - 71 A 4	393
	<b>4,25</b>	52	1	MR C3I 80 - 71 A 4	329
	<b>4,25</b>	52	1,06	MR C3I 81 - 71 A 4	329
	<b>5,53</b>	39,7	0,85	MR C3I 64 - 71 A 4	253
	<b>5,32</b>	41,3	1,4	MR C3I 80 - 71 A 4	263
	<b>5,32</b>	41,3	1,6	MR C3I 81 - 71 A 4	263
	<b>6,91</b>	31,8	0,85	MR C3I 63 - 71 A 4	202
	<b>6,91</b>	31,8	1,06	MR C3I 64 - 71 A 4	202
	<b>7,05</b>	31,2	1	MR C3I 63 - 71 B 6	128
	<b>7,05</b>	31,2	1,25	MR C3I 64 - 71 B 6	128
	<b>7,58</b>	29,6	0,95	MR ICI 64 - 71 B 6	119
	<b>6,65</b>	33	1,8	MR C3I 80 - 71 A 4	211
	<b>6,65</b>	33	2	MR C3I 81 - 71 A 4	211
	<b>7,29</b>	30,8	1,7	MR ICI 80 - 71 B 6	124
	<b>7,29</b>	30,8	1,8	MR ICI 81 - 71 B 6	124
	<b>8,64</b>	25,4	1,18	MR C3I 63 - 71 A 4	162
	<b>8,64</b>	25,4	1,32	MR C3I 64 - 71 A 4	162
	<b>9,47</b>	23,7	1,12	MR ICI 63 - 71 B 6	95
	<b>9,47</b>	23,7	1,4	MR ICI 64 - 71 B 6	95
	<b>8,3</b>	26,5	2,36	MR C3I 80 - 71 A 4	169
	<b>9,11</b>	24,6	2,36	MR ICI 80 - 71 B 6	98,8
	<b>9,11</b>	24,6	2,65	MR ICI 81 - 71 B 6	98,8
	<b>11,3</b>	19,5	0,85	MR C3I 50 - 71 A 4	124
	<b>11</b>	20	1,6	MR C3I 63 - 71 A 4	128
	<b>11</b>	20	1,9	MR C3I 64 - 71 A 4	128
	<b>11,8</b>	19	1,18	MR ICI 63 - 71 A 4	119
<b>11,8</b>	19	1,5	MR ICI 64 - 71 A 4	119	
<b>11,3</b>	19,8	1,4	MR ICI 63 - 71 B 6	79,5	
<b>11,3</b>	19,8	1,7	MR ICI 64 - 71 B 6	79,5	
<b>11,3</b>	19,8	2,65	MR ICI 80 - 71 A 4	124	
<b>11,3</b>	19,8	2,8	MR ICI 81 - 71 A 4	124	
<b>14,3</b>	15,4	1,06	MR C3I 50 - 71 A 4	97,9	
<b>14,7</b>	15,2	0,95	MR ICI 50 - 71 B 6	61,1	
<b>14,7</b>	15,2	1,8	MR ICI 63 - 71 A 4	95	
<b>14,7</b>	15,2	2,24	MR ICI 64 - 71 A 4	95	
<b>14,2</b>	15,8	3,75	MR ICI 80 - 71 A 4	98,8	

1) Leistungen bei Dauerbetrieb S1; bei Betriebsarten S2 ... S10 können sie gesteigert werden (s. Kap. 2b); M<sub>2</sub> steigt und f<sub>s</sub> fällt proportional.  
2) Zur vollständigen Bestellbezeichnung s. Kap. 3.

1) Powers valid for continuous duty S1; increase possible for S2 ... S10 (see ch. 2b); in which case M<sub>2</sub> increases and f<sub>s</sub> decreases proportionately.  
2) For complete designation when ordering see ch. 3.





14 - Herstellungsprogramm (Kegelstirradtriebemotoren)  
 14 - Manufacturing programme (right angle shafts)

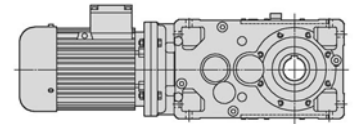
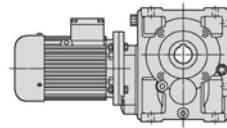

$P_1$ kW	$n_2$ min <sup>-1</sup>	$M_2$ daN m	$f_s$	Getriebe - Motor Gear reducer - Motor	$i$
1)				2)	
<b>0,75</b>	<b>27,6</b>	24,4	1,12	MR ICI 63 - 80 B 4	50,8
	<b>27,6</b>	24,4	1,4	MR ICI 64 - 80 B 4	50,8
	<b>28,1</b>	24	1,32	MR ICI 63 - 80 C 6	32
	<b>28,1</b>	24	1,6	MR ICI 64 - 80 C 6	32
	<b>28,8</b>	23,9	0,9	MR CI 63 - 80 C 6	31,3
	<b>28,8</b>	23,9	1,06	MR CI 64 - 80 C 6	31,3
	<b>28,8</b>	23,9	0,9	MR CI 63 - 90 S 6	31,3
	<b>28,8</b>	23,9	1,06	MR CI 64 - 90 S 6	31,3
	<b>26,5</b>	25,4	2,24	MR ICI 80 - 80 B 4	52,8
	<b>27,7</b>	24,8	1,8	MR CI 80 - 80 C 6	32,5
	<b>27,7</b>	24,8	1,8	MR CI 80 - 90 S 6	32,5
	<b>35,2</b>	19,1	0,85	MR ICI 50 - 80 B *4	39,8
	<b>35,8</b>	18,8	0,9	MR ICI 50 - 80 C 6	25,1
	<b>34,5</b>	19,5	1,4	MR ICI 63 - 80 B 4	40,6
	<b>34,5</b>	19,5	1,7	MR ICI 64 - 80 B 4	40,6
	<b>36</b>	19,1	1,4	MR CI 63 - 80 C 6	25
	<b>36</b>	19,1	1,7	MR CI 64 - 80 C 6	25
	<b>36</b>	19,1	1,4	MR CI 63 - 90 S 6	25
	<b>36</b>	19,1	1,7	MR CI 64 - 90 S 6	25
	<b>33,1</b>	20,3	3	MR ICI 80 - 80 B 4	42,3
	<b>34,6</b>	19,9	3	MR CI 80 - 80 C 6	26
	<b>34,6</b>	19,9	3	MR CI 80 - 90 S 6	26
	<b>43,9</b>	15,3	1,06	MR ICI 50 - 80 B 4	31,9
	<b>46,7</b>	14,7	1	MR CI 50 - 80 C 6	19,3
	<b>43,7</b>	15,4	2	MR ICI 63 - 80 B 4	32
	<b>43,7</b>	15,4	2,5	MR ICI 64 - 80 B 4	32
	<b>44,8</b>	15,3	1,32	MR CI 63 - 80 B 4	31,3
	<b>44,8</b>	15,3	1,6	MR CI 64 - 80 B 4	31,3
	<b>45</b>	15,3	1,8	MR CI 63 - 80 C 6	20
	<b>45</b>	15,3	2,12	MR CI 64 - 80 C 6	20
	<b>45</b>	15,3	1,8	MR CI 63 - 90 S 6	20
	<b>45</b>	15,3	2,12	MR CI 64 - 90 S 6	20
	<b>43,1</b>	16	2,65	MR CI 80 - 80 B 4	32,5
	<b>55,7</b>	12,1	1,32	MR ICI 50 - 80 B 4	25,1
	<b>58,1</b>	11,8	1,18	MR CI 50 - 80 B 4	24,1
	<b>56</b>	12,3	2,24	MR CI 63 - 80 B 4	25
	<b>66,9</b>	10,1	1,6	MR ICI 50 - 80 B 4	20,9
	<b>72,6</b>	9,5	1,5	MR CI 50 - 80 B 4	19,3
	<b>70</b>	9,8	2,65	MR CI 63 - 80 B 4	20
	<b>89,2</b>	7,7	1,8	MR CI 50 - 80 B 4	15,7
	<b>87,5</b>	7,9	3,15	MR CI 63 - 80 B 4	16
<b>102</b>	6,7	1	MR CI 40 - 71 D 4	13,7	
<b>113</b>	6,1	2,65	MR CI 50 - 80 B 4	12,4	
<b>124</b>	5,5	1,32	MR CI 40 - 71 D 4	11,3	
<b>136</b>	5,1	2,65	MR CI 50 - 80 B 4	10,3	
<b>161</b>	4,28	1,5	MR CI 40 - 71 D 4	8,72	
<b>174</b>	3,96	2,65	MR CI 50 - 80 B 4	8,06	
<b>202</b>	3,41	1,5	MR CI 40 - 71 D 4	6,94	
<b>217</b>	3,17	2,65	MR CI 50 - 80 B 4	6,46	
<b>1,1</b>	<b>3,72</b>	260	0,85	MR C3I 125 - 90 S 4	377
	<b>4,59</b>	211	1,06	MR C3I 125 - 90 S 4	305
	<b>5,73</b>	169	1,4	MR C3I 125 - 90 S 4	244
	<b>7,18</b>	135	0,9	MR C3I 100 - 80 C 4	195
	<b>7,19</b>	134	0,9	MR C3I 100 - 90 S 4	195
	<b>7,17</b>	135	1,8	MR C3I 125 - 90 S 4	195
	<b>7,47</b>	132	1,7	MR ICI 125 - 90 L 6	121
	<b>8,81</b>	110	1,18	MR C3I 100 - 80 C 4	159
	<b>8,99</b>	107	1,12	MR C3I 100 - 90 S 4	156
	<b>10,1</b>	98	1,12	MR ICI 100 - 80 C 4	139
	<b>8,96</b>	108	2,65	MR C3I 125 - 90 S 4	156
	<b>9,33</b>	106	2,24	MR ICI 125 - 90 L 6	96,4
	<b>11,2</b>	86	1,6	MR C3I 100 - 80 C 4	125
	<b>11</b>	87	1,5	MR C3I 100 - 90 S 4	127
	<b>12,2</b>	81	1,18	MR ICI 100 - 80 C 4	114
	<b>11,8</b>	84	1,12	MR ICI 100 - 90 L 6	76,4
	<b>11,6</b>	85	2,65	MR ICI 125 - 90 S 4	121
	<b>13,2</b>	73	0,9	MR C3I 80 - 80 C 4	106
	<b>13,2</b>	73	1,06	MR C3I 81 - 80 C 4	106
	<b>14</b>	69	2	MR C3I 100 - 90 S 4	99,9
	<b>15,3</b>	65	1,9	MR ICI 100 - 80 C 4	91,5
	<b>15,1</b>	66	1,7	MR ICI 100 - 90 S 4	92,9
	<b>14,7</b>	67	1,8	MR ICI 100 - 90 L 6	61,2

$P_1$ kW	$n_2$ min <sup>-1</sup>	$M_2$ daN m	$f_s$	Getriebe - Motor Gear reducer - Motor	$i$
1)				2)	
<b>1,1</b>	<b>14,5</b>	68	3,55	MR ICI 125 - 90 S 4	96,4
	<b>17</b>	58	0,85	MR ICI 80 - 80 C 4	82,5
	<b>17</b>	58	0,95	MR ICI 81 - 80 C 4	82,5
	<b>17,3</b>	57	1	MR ICI 80 - 90 L 6	52
	<b>17,3</b>	57	1,18	MR ICI 81 - 90 L 6	52
	<b>18,3</b>	54	2,24	MR ICI 100 - 80 C 4	76,7
	<b>18,3</b>	54	1,7	MR ICI 100 - 90 S 4	76,4
	<b>18,4</b>	54	2,24	MR ICI 100 - 90 L 6	48,9
	<b>21,2</b>	46,6	1,25	MR ICI 80 - 80 C 4	66
	<b>21,2</b>	46,6	1,4	MR ICI 81 - 80 C 4	66
	<b>21,5</b>	45,8	1,06	MR ICI 80 - 90 S 4	65
	<b>21,5</b>	45,8	1,18	MR ICI 81 - 90 S 4	65
	<b>21,6</b>	45,6	1,25	MR ICI 80 - 90 L 6	41,6
	<b>21,6</b>	45,6	1,5	MR ICI 81 - 90 L 6	41,6
	<b>22,8</b>	43,3	2,8	MR ICI 100 - 80 C 4	61,3
	<b>22,9</b>	43,1	2,8	MR ICI 100 - 90 S 4	61,2
	<b>24,6</b>	41	2,36	MR CI 100 - 90 L 6	36,6
	<b>27,6</b>	35,8	0,95	MR ICI 64 - 80 C 4	50,8
	<b>28</b>	35,3	0,95	MR ICI 64 - 90 S 4	50
	<b>28,1</b>	35,1	0,8	MR ICI 63 - 90 L 6	32
	<b>26,5</b>	37,2	1,6	MR ICI 80 - 80 C 4	52,8
	<b>26,5</b>	37,2	1,8	MR ICI 81 - 80 C 4	52,8
	<b>26,9</b>	36,7	1,6	MR ICI 80 - 90 S 4	52
	<b>26,9</b>	36,7	1,8	MR ICI 81 - 90 S 4	52
	<b>27,7</b>	36,4	1,18	MR CI 80 - 90 L 6	32,5
	<b>27,7</b>	36,4	1,5	MR CI 81 - 90 L 6	32,5
	<b>28</b>	35,2	3,75	MR ICI 100 - 80 C 4	49,9
	<b>28,6</b>	34,5	3,55	MR ICI 100 - 90 S 4	48,9
	<b>29,9</b>	33,7	2,65	MR CI 100 - 90 L 6	30,1
	<b>34,5</b>	28,6	1	MR ICI 63 - 80 C 4	40,6
	<b>34,5</b>	28,6	1,18	MR ICI 64 - 80 C 4	40,6
	<b>35</b>	28,2	0,95	MR ICI 63 - 90 S 4	40
	<b>35</b>	28,2	1,18	MR ICI 64 - 90 S 4	40
	<b>35,7</b>	27,7	1,12	MR ICI 63 - 90 L 6	25,2
	<b>35,7</b>	27,7	1,4	MR ICI 64 - 90 L 6	25,2
	<b>36</b>	28	0,95	MR CI 63 - 90 L 6	25
	<b>36</b>	28	1,18	MR CI 64 - 90 L 6	25
	<b>33,1</b>	29,8	2,12	MR ICI 80 - 80 C 4	42,3
	<b>33,1</b>	29,8	2,36	MR ICI 81 - 80 C 4	42,3
	<b>33,7</b>	29,3	2	MR ICI 80 - 90 S 4	41,6
	<b>33,7</b>	29,3	2,24	MR ICI 81 - 90 S 4	41,6
	<b>34,6</b>	29,1	2	MR CI 80 - 90 L 6	26
	<b>34,6</b>	29,1	2,24	MR CI 81 - 90 L 6	26
	<b>43,7</b>	22,6	1,4	MR ICI 63 - 80 C 4	32
	<b>43,7</b>	22,6	1,7	MR ICI 64 - 80 C 4	32
	<b>43,8</b>	22,6	1,25	MR ICI 63 - 90 S 4	32
<b>43,8</b>	22,6	1,5	MR ICI 64 - 90 S 4	32	
<b>44,8</b>	22,5	0,95	MR CI 63 - 80 C 4	31,3	
<b>44,8</b>	22,5	1,06	MR CI 64 - 80 C 4	31,3	
<b>44,8</b>	22,5	0,95	MR CI 63 - 90 S 4	31,3	
<b>44,8</b>	22,5	1,06	MR CI 64 - 90 S 4	31,3	
<b>45</b>	22,4	1,18	MR CI 63 - 90 L 6	20	
<b>45</b>	22,4	1,5	MR CI 64 - 90 L 6	20	
<b>42</b>	23,5	2,8	MR ICI 80 - 80 C 4	33,4	
<b>42</b>	23,5	2,65	MR ICI 80 - 90 S 4	33,3	
<b>43,1</b>	23,4	1,9	MR CI 80 - 80 C 4	32,5	
<b>43,1</b>	23,4	2,24	MR CI 81 - 80 C 4	32,5	
<b>43,1</b>	23,4	1,9	MR CI 80 - 90 S 4	32,5	
<b>43,1</b>	23,4	2,24	MR CI 81 - 90 S 4	32,5	
<b>43,3</b>	23,3	2,5	MR CI 80 - 90 L 6	20,8	
<b>46,5</b>	21,7	4,25	MR CI 100 - 90 S 4	30,1	
<b>55,7</b>	17,7	0,95	MR ICI 50 - 80 C 4	25,1	
<b>58,1</b>	17,4	0,8	MR CI 50 - 80 C 4	24,1	
<b>55,5</b>	17,8	1,8	MR ICI 63 - 90 S 4	25,2	
<b>55,5</b>	17,8	2,12	MR ICI 64 - 90 S 4	25,2	
<b>56</b>	18	1,5	MR CI 63 - 80 C 4	25	
<b>56</b>	18	1,8	MR CI 64 - 80 C 4	25	
<b>56</b>	18	1,5	MR CI 63 - 90 S 4	25	
<b>56</b>	18	1,8	MR CI 64 - 90 S 4	25	
<b>53,8</b>	18,7	3	MR CI 80 - 80 C 4	26	
<b>53,8</b>	18,7	3	MR CI 80 - 90 S 4	26	
<b>66,9</b>	14,8	1,06	MR ICI 50 - 80 C 4	20,9	
<b>72,6</b>	13,9	1	MR CI 50 - 80 C 4	19,3	
<b>67,6</b>	14,6	1,8	MR ICI 63 - 90 S 4	20,7	
<b>67,6</b>	14,6	2,12	MR ICI 64 - 90 S 4	20,7	
<b>70</b>	14,4	1,9	MR CI 63 - 80 C 4	20	

1) Leistungen bei Dauerbetrieb S1; bei Betriebsarten S2 ... S10 können sie **gesteigert** werden (s. Kap. 2b);  $M_2$  steigt und  $f_s$  fällt proportional.  
 2) Zur vollständigen Bestellbezeichnung s. Kap. 3.  
 \* Bauform **B5R** (s. Tabelle Kap. 2b).

1) Powers valid for continuous duty S1; **increase** possible for S2 ... S10 (see ch. 2b); in which case  $M_2$  increases and  $f_s$  decreases proportionately.  
 2) For complete designation when ordering see ch. 3.  
 \* Mounting position **B5R** (see table ch. 2b).

14 - Herstellungsprogramm (Kegelstirnradgetriebemotoren)  
14 - Manufacturing programme (right angle shafts)

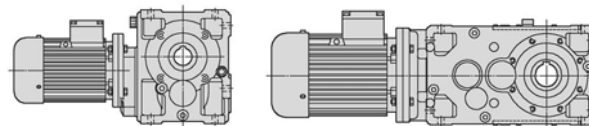

P <sub>1</sub> kW	n <sub>2</sub> min <sup>-1</sup>	M <sub>2</sub> daNm	f <sub>s</sub>	Getriebe - Motor Gear reducer - Motor	i	
1)				2)		
1,1	70	14,4	2,24	MR CI 64 - 80 C 4	20	
	70	14,4	1,9	MR CI 63 - 90 S 4	20	
	70	14,4	2,24	MR CI 64 - 90 S 4	20	
	89,2	11,3	1,25	MR CI 50 - 80 C 4	15,7	
	87,5	11,5	2,24	MR CI 63 - 80 C 4	16	
	87,5	11,5	2,24	MR CI 63 - 90 S 4	16	
	113	8,9	1,8	MR CI 50 - 80 C 4	12,4	
	111	9,1	3,35	MR CI 63 - 80 C 4	12,6	
	111	9,1	3,35	MR CI 63 - 90 S 4	12,6	
	136	7,4	1,8	MR CI 50 - 80 C 4	10,3	
	135	7,5	3,15	MR CI 63 - 80 C 4	10,4	
	135	7,5	3,15	MR CI 63 - 90 S 4	10,4	
	174	5,8	1,8	MR CI 50 - 80 C 4	8,06	
	175	5,7	3,15	MR CI 63 - 80 C 4	7,98	
	175	5,7	3,15	MR CI 63 - 90 S 4	7,98	
	217	4,65	1,8	MR CI 50 - 80 C 4	6,46	
	222	4,54	3,15	MR CI 63 - 80 C 4	6,31	
	222	4,54	3,15	MR CI 63 - 90 S 4	6,31	
	1,5	4,61	286	0,85	MR C3I 125 - 90 LC 6	195
		4,54	290	0,85	MR C3I 125 - 100 LA 6	198
		5,73	230	1,06	MR C3I 125 - 90 L 4	244
		5,98	225	1,6	MR C2I 140 - 100 LA 6	151
		5,85	230	2,36	MR C2I 160 - 100 LA 6	154
		7,17	184	1,32	MR C3I 125 - 90 L 4	195
7,47		180	1,25	MR ICI 125 - 90 LC 6	121	
7,33		184	2	MR C2I 140 - 100 LA 6	123	
7,31		184	2,36	MR ICI 160 - 100 LA 6	123	
8,99		147	0,85	MR C3I 100 - 90 L 4	156	
10,1		134	0,8	MR ICI 100 - 90 L *4	139	
9,69		139	0,8	MR ICI 100 - 90 LC 6	92,9	
8,96		147	1,9	MR C3I 125 - 90 L 4	156	
9,33		144	1,7	MR ICI 125 - 90 LC 6	96,4	
9,22		146	1,5	MR ICI 125 - 100 LA 6	97,7	
9,33		144	2,12	MR ICI 140 - 90 LC 6	96,4	
9,16		147	2,8	MR C2I 140 - 100 LA 6	98,2	
10,3		131	3,15	MR C2I 140 - 100 LA 6	87,8	
11		119	1,12	MR C3I 100 - 90 L 4	127	
12,2		110	0,85	MR ICI 100 - 90 L *4	114	
11,8		114	0,85	MR ICI 100 - 90 LC 6	76,4	
12,3		110	1	MR ICI 100 - 100 LA 6	73,2	
11,4		116	2,36	MR C3I 125 - 90 L 4	123	
11,6		116	1,9	MR ICI 125 - 90 L 4	121	
11,5		117	2,65	MR ICI 140 - 100 LA 6	78,1	
11,5		118	3,55	MR C2I 140 - 100 LA 6	78,6	
14		94	1,5	MR C3I 100 - 90 L 4	99,9	
15,3		88	1,4	MR ICI 100 - 90 L *4	91,5	
15,1		89	1,18	MR ICI 100 - 90 L 4	92,9	
14,7		91	1,32	MR ICI 100 - 90 LC 6	61,2	
14,9		90	1,06	MR ICI 100 - 100 LA 6	60,2	
14,5		93	2,65	MR ICI 125 - 90 L 4	96,4	
17,3		78	0,85	MR ICI 81 - 90 LC 6	52	
18,3		74	1,7	MR ICI 100 - 90 L *4	76,7	
18,3		74	1,25	MR ICI 100 - 90 L 4	76,4	
18,4		73	1,7	MR ICI 100 - 90 LC 6	48,9	
18,7		72	1,7	MR ICI 100 - 100 LA 6	48,2	
17,9		75	3,15	MR ICI 125 - 90 L 4	78,1	
21,2		63	0,9	MR ICI 80 - 90 L *4	66	
21,5		63	0,8	MR ICI 80 - 90 L 4	65	
21,2		63	1,06	MR ICI 81 - 90 L *4	66	
21,5		63	0,85	MR ICI 81 - 90 L 4	65	
21,6		62	0,95	MR ICI 80 - 90 LC 6	41,6	
21,6		62	1,06	MR ICI 81 - 90 LC 6	41,6	
22,9		59	2,12	MR ICI 100 - 90 L 4	61,2	
24,6		56	1,8	MR CI 100 - 90 LC 6	36,6	
24,6		56	1,8	MR CI 100 - 100 LA 6	36,6	
26,9		50	1,18	MR ICI 80 - 90 L 4	52	
26,9		50	1,32	MR ICI 81 - 90 L 4	52	
27		49,9	1,25	MR ICI 80 - 90 LC 6	33,3	
27		49,9	1,4	MR ICI 81 - 90 LC 6	33,3	
27,7		49,7	0,9	MR CI 80 - 90 LC 6	32,5	
27,7		49,7	1,06	MR CI 81 - 90 LC 6	32,5	
27,7		49,7	0,9	MR CI 80 - 100 LA 6	32,5	

1) Leistungen bei Dauerbetrieb S1; bei Betriebsarten S2 ... S10 können sie gesteigert werden (s. Kap. 2b); M<sub>2</sub> steigt und f<sub>s</sub> fällt proportional.  
2) Zur vollständigen Bestellbezeichnung s. Kap. 3.  
\* Bauform **B5R** (s. Tabelle Kap. 2b).

P <sub>1</sub> kW	n <sub>2</sub> min <sup>-1</sup>	M <sub>2</sub> daNm	f <sub>s</sub>	Getriebe - Motor Gear reducer - Motor	i
1)				2)	
1,5	27,7	49,7	1,06	MR CI 81 - 100 LA 6	32,5
	28,6	47,1	2,65	MR ICI 100 - 90 L 4	48,9
	29,9	46	2	MR CI 100 - 90 LC 6	30,1
	29,9	46	2	MR CI 100 - 100 LA 6	30,1
	35	38,5	0,85	MR ICI 64 - 90 L 4	40
	35,7	37,7	0,85	MR ICI 63 - 90 LC 6	25,2
	35,7	37,7	1	MR ICI 64 - 90 LC 6	25,2
	36	38,2	0,85	MR CI 64 - 90 LC 6	25
	33,7	40	1,4	MR ICI 80 - 90 L 4	41,6
	33,7	40	1,7	MR ICI 81 - 90 L 4	41,6
	34,2	39,3	1,7	MR ICI 80 - 90 LC 6	26,3
	34,2	39,3	2	MR ICI 81 - 90 LC 6	26,3
	34,6	39,7	1,5	MR CI 80 - 90 LC 6	26
	34,6	39,7	1,7	MR CI 81 - 90 LC 6	26
	34,6	39,7	1,5	MR CI 80 - 100 LA 6	26
	34,6	39,7	1,7	MR CI 81 - 100 LA 6	26
	35,1	38,3	3,35	MR ICI 100 - 90 L 4	39,8
	38,2	36	2,65	MR CI 100 - 90 L 4	36,6
	37,4	36,8	3	MR CI 100 - 90 LC 6	24,1
	37,4	36,8	3	MR CI 100 - 100 LA 6	24,1
	43,8	30,8	0,9	MR ICI 63 - 90 L 4	32
	43,8	30,8	1,06	MR ICI 64 - 90 L 4	32
	44,8	30,7	0,8	MR CI 64 - 90 L 4	31,3
	45	30,6	0,9	MR CI 63 - 90 LC 6	20
	45	30,6	1,06	MR CI 64 - 90 LC 6	20
	42	32,1	1,9	MR ICI 80 - 90 L 4	33,3
	42	32,1	2,12	MR ICI 81 - 90 L 4	33,3
	43,1	31,9	1,32	MR CI 80 - 90 L 4	32,5
	43,1	31,9	1,6	MR CI 81 - 90 L 4	32,5
	43,3	31,8	1,8	MR CI 80 - 90 LC 6	20,8
	43,3	31,8	2,12	MR CI 81 - 90 LC 6	20,8
	43,3	31,8	1,8	MR CI 80 - 100 LA 6	20,8
	43,3	31,8	2,12	MR CI 81 - 100 LA 6	20,8
	46,5	29,6	3	MR CI 100 - 90 L 4	30,1
	55,5	24,3	1,32	MR ICI 63 - 90 L 4	25,2
	55,5	24,3	1,6	MR ICI 64 - 90 L 4	25,2
	56	24,6	1,12	MR CI 63 - 90 L 4	25
	56	24,6	1,32	MR CI 64 - 90 L 4	25
	53,3	25,3	2,65	MR ICI 80 - 90 L 4	26,3
	53,8	25,5	2,24	MR CI 80 - 90 L 4	26
	53,8	25,5	2,5	MR CI 81 - 90 L 4	26
	67,6	19,9	1,32	MR ICI 63 - 90 L 4	20,7
	67,6	19,9	1,6	MR ICI 64 - 90 L 4	20,7
	70	19,6	1,32	MR CI 63 - 90 L 4	20
	70	19,6	1,7	MR CI 64 - 90 L 4	20
	70,8	19	2,8	MR ICI 80 - 90 L 4	19,8
	67,3	20,4	2,8	MR CI 80 - 90 L 4	20,8
	89,2	15,4	0,9	MR CI 50 - 80 D 4	15,7
	87,5	15,7	1,6	MR CI 63 - 90 L 4	16
	87,5	15,7	2	MR CI 64 - 90 L 4	16
	113	12,2	1,32	MR CI 50 - 80 D 4	12,4
111	12,4	2,5	MR CI 63 - 90 L 4	12,6	
136	10,1	1,32	MR CI 50 - 80 D 4	10,3	
135	10,2	2,36	MR CI 63 - 90 L 4	10,4	
174	7,9	1,32	MR CI 50 - 80 D 4	8,06	
175	7,8	2,36	MR CI 63 - 90 L 4	7,98	
217	6,3	1,32	MR CI 50 - 80 D 4	6,46	
222	6,2	2,36	MR CI 63 - 90 L 4	6,31	
1,85	5,73	283	0,85	MR C3I 125 - 90 LB 4	244
	5,98	278	1,25	MR C2I 140 - 100 LB 6	151
	5,85	284	1,9	MR C2I 160 - 100 LB 6	154
	5,68	292	2,5	MR C2I 180 - 100 LB 6	158
	7,17	227	1,06	MR C3I 125 - 90 LB 4	195
	7,33	227	1,6	MR C2I 140 - 100 LB 6	123
	7,31	227	1,9	MR ICI 160 - 100 LB 6	123
	6,97	238	2,65	MR C2I 160 - 100 LB 6	129
	8,96	181	1,5	MR C3I 125 - 90 LB 4	156
	9,22	180	1,25	MR ICI 125 - 100 LB 6	97,7
	9,16	181	2,24	MR C2I 140 - 100 LB 6	98,2
	10,3	162	2,65	MR C2I 140 - 100 LB 6	87,8
	11	147	0,9	MR C3I 100 - 90 LB 4	127
	12,3	135	0,8	MR ICI 100 - 100 LB 6	73,2
11,4	143	2	MR C3I 125 - 90 LB 4	123	

1) Powers valid for continuous duty S1; increase possible for S2 ... S10 (see ch. 2b); in which case M<sub>2</sub> increases and f<sub>s</sub> decreases proportionately.  
2) For complete designation when ordering see ch. 3.  
\* Mounting position **B5R** (see table ch. 2b).



14 - Herstellungsprogramm (Kegelstirnradgetriebemotoren)  
 14 - Manufacturing programme (right angle shafts)

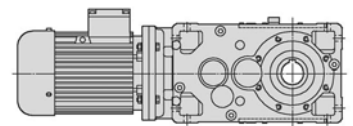
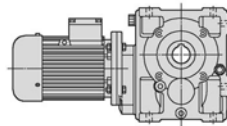

P <sub>1</sub> kW	n <sub>2</sub> min <sup>-1</sup>	M <sub>2</sub> daN m	f <sub>s</sub>	Getriebe - Motor Gear reducer - Motor	i
1)				2)	
<b>1,85</b>	<b>11,6</b>	143	1,5	MR ICI 125 - 90 LB 4	121
	<b>11,5</b>	144	2,12	MR ICI 140 - 100 LB 6	78,1
	<b>11,5</b>	145	2,8	MR C2I 140 - 100 LB 6	78,6
	<b>12,8</b>	130	3,35	MR C2I 140 - 100 LB 6	70,2
	<b>14</b>	116	1,18	MR C3I 100 - 90 LB 4	99,9
	<b>15,3</b>	109	1,12	MR ICI 100 - 90 LB *4	91,5
	<b>15,1</b>	110	1	MR ICI 100 - 90 LB 4	92,9
	<b>14,5</b>	114	2,12	MR ICI 125 - 90 LB 4	96,4
	<b>14,5</b>	114	2,65	MR ICI 140 - 90 LB 4	96,4
	<b>18,3</b>	91	1,32	MR ICI 100 - 90 LB *4	76,7
	<b>18,3</b>	91	1	MR ICI 100 - 90 LB 4	76,4
	<b>18,7</b>	89	1,4	MR ICI 100 - 100 LB 6	48,2
	<b>17,9</b>	93	2,65	MR ICI 125 - 90 LB 4	78,1
	<b>21,2</b>	78	0,85	MR ICI 81 - 90 LB *4	66
	<b>22,9</b>	73	1,7	MR ICI 100 - 90 LB 4	61,2
	<b>24,6</b>	69	1,4	MR CI 100 - 100 LB 6	36,6
	<b>22,4</b>	74	3,35	MR ICI 125 - 90 LB 4	62,5
	<b>26,9</b>	62	0,95	MR ICI 80 - 90 LB 4	52
	<b>26,9</b>	62	1,06	MR ICI 81 - 90 LB 4	52
	<b>27,7</b>	61	0,85	MR CI 81 - 100 LB 6	32,5
	<b>28,6</b>	58	2,12	MR ICI 100 - 90 LB 4	48,9
	<b>29,9</b>	57	1,6	MR CI 100 - 100 LB 6	30,1
	<b>33,7</b>	49,3	1,18	MR ICI 80 - 90 LB 4	41,6
	<b>33,7</b>	49,3	1,32	MR ICI 81 - 90 LB 4	41,6
	<b>34,6</b>	49	1,18	MR CI 80 - 100 LB 6	26
	<b>34,6</b>	49	1,32	MR CI 81 - 100 LB 6	26
	<b>35,1</b>	47,3	2,8	MR ICI 100 - 90 LB 4	39,8
	<b>38,2</b>	44,3	2,24	MR CI 100 - 90 LB 4	36,6
	<b>37,4</b>	45,4	2,5	MR CI 100 - 100 LB 6	24,1
	<b>43,7</b>	38	0,85	MR ICI 63 - 90 LB *4	32
	<b>43,7</b>	38	1	MR ICI 64 - 90 LB *4	32
	<b>43,8</b>	38	0,9	MR ICI 64 - 90 LB 4	32
	<b>42</b>	39,5	1,5	MR ICI 80 - 90 LB 4	33,3
	<b>42</b>	39,5	1,8	MR ICI 81 - 90 LB 4	33,3
	<b>43,1</b>	39,4	1,12	MR CI 80 - 90 LB 4	32,5
	<b>43,1</b>	39,4	1,32	MR CI 81 - 90 LB 4	32,5
	<b>43,3</b>	39,2	1,5	MR CI 80 - 100 LB 6	20,8
	<b>43,3</b>	39,2	1,7	MR CI 81 - 100 LB 6	20,8
	<b>46,5</b>	36,5	2,5	MR CI 100 - 90 LB 4	30,1
	<b>55,5</b>	29,9	1,06	MR ICI 63 - 90 LB 4	25,2
	<b>55,5</b>	29,9	1,25	MR ICI 64 - 90 LB 4	25,2
	<b>56</b>	30,3	0,9	MR CI 63 - 90 LB 4	25
	<b>56</b>	30,3	1,06	MR CI 64 - 90 LB 4	25
	<b>53,3</b>	31,2	2,12	MR ICI 80 - 90 LB 4	26,3
	<b>53,3</b>	31,2	2,5	MR ICI 81 - 90 LB 4	26,3
	<b>53,8</b>	31,5	1,8	MR CI 80 - 90 LB 4	26
	<b>53,8</b>	31,5	2,12	MR CI 81 - 90 LB 4	26
<b>58,1</b>	29,2	3,75	MR CI 100 - 90 LB 4	24,1	
<b>67,6</b>	24,6	1,06	MR ICI 63 - 90 LB 4	20,7	
<b>67,6</b>	24,6	1,25	MR ICI 64 - 90 LB 4	20,7	
<b>70</b>	24,2	1,12	MR CI 63 - 90 LB 4	20	
<b>70</b>	24,2	1,32	MR CI 64 - 90 LB 4	20	
<b>70,8</b>	23,4	2,24	MR ICI 80 - 90 LB 4	19,8	
<b>67,3</b>	25,2	2,24	MR CI 80 - 90 LB 4	20,8	
<b>67,3</b>	25,2	2,65	MR CI 81 - 90 LB 4	20,8	
<b>87,5</b>	19,4	1,32	MR CI 63 - 90 LB 4	16	
<b>87,5</b>	19,4	1,7	MR CI 64 - 90 LB 4	16	
<b>84</b>	20,2	3	MR CI 80 - 90 LB 4	16,7	
<b>111</b>	15,3	2	MR CI 63 - 90 LB 4	12,6	
<b>111</b>	15,3	2,5	MR CI 64 - 90 LB 4	12,6	
<b>135</b>	12,6	1,9	MR CI 63 - 90 LB 4	10,4	
<b>135</b>	12,6	2,5	MR CI 64 - 90 LB 4	10,4	
<b>175</b>	9,7	1,9	MR CI 63 - 90 LB 4	7,98	
<b>175</b>	9,7	2,5	MR CI 64 - 90 LB 4	7,98	
<b>222</b>	7,6	1,9	MR CI 63 - 90 LB 4	6,31	
<b>222</b>	7,6	2,5	MR CI 64 - 90 LB 4	6,31	
<b>2,2</b>	<b>5,98</b>	330	1,06	MR C2I 140 - 112 M 6	151
	<b>5,85</b>	338	1,6	MR C2I 160 - 112 M 6	154
	<b>5,68</b>	348	2,12	MR C2I 180 - 112 M 6	158
	<b>7,17</b>	270	0,9	MR C3I 125 - 90 LC 4	195
	<b>7,07</b>	274	0,9	MR C3I 125 - 100 LA 4	198
	<b>7,1</b>	272	1	MR C3I 125 - 112 M 6	127

P <sub>1</sub> kW	n <sub>2</sub> min <sup>-1</sup>	M <sub>2</sub> daN m	f <sub>s</sub>	Getriebe - Motor Gear reducer - Motor	i
1)				2)	
<b>2,2</b>	<b>7,33</b>	269	1,32	MR C2I 140 - 112 M 6	123
	<b>7,31</b>	270	1,6	MR ICI 160 - 112 M 6	123
	<b>6,97</b>	283	2,12	MR C2I 160 - 112 M 6	129
	<b>8,96</b>	216	1,32	MR C3I 125 - 90 LC 4	156
	<b>8,83</b>	219	1,12	MR C3I 125 - 100 LA 4	158
	<b>9,22</b>	214	1	MR ICI 125 - 112 M 6	97,7
	<b>9,3</b>	212	1,7	MR C2I 140 - 100 LA 4	151
	<b>9,16</b>	216	1,9	MR C2I 140 - 112 M 6	98,2
	<b>9,14</b>	216	2,5	MR ICI 160 - 112 M 6	98,5
	<b>9,1</b>	217	2,5	MR C2I 160 - 100 LA 4	154
	<b>11,4</b>	170	1,6	MR C3I 125 - 90 LC 4	123
	<b>11</b>	175	1,5	MR C3I 125 - 100 LA 4	127
	<b>11,6</b>	170	1,32	MR ICI 125 - 90 LC 4	121
	<b>11,5</b>	171	1,4	MR ICI 125 - 112 M 6	78,1
	<b>11,5</b>	171	1,8	MR ICI 140 - 112 M 6	78,1
	<b>11,4</b>	173	2,12	MR C2I 140 - 100 LA 4	123
	<b>11,4</b>	174	2,5	MR ICI 160 - 100 LA 4	123
	<b>14</b>	138	1	MR C3I 100 - 90 LC 4	99,9
	<b>15,3</b>	129	0,95	MR ICI 100 - 90 LC *4	91,5
	<b>15,1</b>	131	0,85	MR ICI 100 - 90 LC 4	92,9
	<b>14</b>	138	2	MR C3I 125 - 100 LA 4	100
	<b>14,5</b>	136	1,8	MR ICI 125 - 90 LC 4	96,4
	<b>14,3</b>	138	1,6	MR ICI 125 - 100 LA 4	97,7
	<b>14,5</b>	136	2,24	MR ICI 140 - 90 LC 4	96,4
	<b>14,3</b>	139	3	MR C2I 140 - 100 LA 4	98,2
	<b>14,2</b>	139	3,75	MR ICI 160 - 100 LA 4	98,5
	<b>16</b>	124	3,35	MR C2I 140 - 100 LA 4	87,8
	<b>18,3</b>	108	1,12	MR ICI 100 - 90 LC *4	76,7
	<b>18,3</b>	108	0,85	MR ICI 100 - 90 LC 4	76,4
	<b>19,1</b>	103	1,06	MR ICI 100 - 100 LA 4	73,2
	<b>18,7</b>	106	1,18	MR ICI 100 - 112 M 6	48,2
	<b>17,9</b>	110	2,24	MR ICI 125 - 100 LA 4	78,1
	<b>17,9</b>	110	2,65	MR ICI 140 - 100 LA 4	78,1
	<b>17,8</b>	111	3,75	MR C2I 140 - 100 LA 4	78,6
	<b>19,9</b>	99	4,25	MR C2I 140 - 100 LA 4	70,2
	<b>22,9</b>	86	1,4	MR ICI 100 - 90 LC 4	61,2
	<b>23,2</b>	85	1,06	MR ICI 100 - 100 LA 4	60,2
	<b>23,3</b>	85	1,4	MR ICI 100 - 112 M 6	38,5
	<b>24,6</b>	82	1,18	MR CI 100 - 112 M 6	36,6
	<b>22,1</b>	89	2,65	MR ICI 125 - 100 LA 4	63,4
	<b>22,6</b>	87	4,75	MR C2I 140 - 100 LA 4	62
	<b>25,3</b>	78	5,3	MR C2I 140 - 100 LA 4	55,4
	<b>26,9</b>	73	0,8	MR ICI 80 - 90 LC 4	52
	<b>26,9</b>	73	0,9	MR ICI 81 - 90 LC 4	52
	<b>28,6</b>	69	1,8	MR ICI 100 - 90 LC 4	48,9
	<b>29,1</b>	68	1,8	MR ICI 100 - 100 LA 4	48,2
	<b>29,9</b>	67	1,32	MR CI 100 - 112 M 6	30,1
<b>27,6</b>	72	3,35	MR ICI 125 - 100 LA 4	50,7	
<b>27,8</b>	71	5,6	MR C2I 140 - 100 LA 4	50,4	
<b>33,7</b>	59	1	MR ICI 80 - 90 LC 4	41,6	
<b>33,7</b>	59	1,12	MR ICI 81 - 90 LC 4	41,6	
<b>34,6</b>	58	1	MR CI 80 - 112 M 6	26	
<b>34,6</b>	58	1,12	MR CI 81 - 112 M 6	26	
<b>35,1</b>	56	2,36	MR ICI 100 - 90 LC 4	39,8	
<b>36,3</b>	54	2,24	MR ICI 100 - 100 LA 4	38,5	
<b>38,2</b>	53	1,9	MR CI 100 - 90 LC 4	36,6	
<b>38,2</b>	53	1,9	MR CI 100 - 100 LA 4	36,6	
<b>37,4</b>	54	2	MR CI 100 - 112 M 6	24,1	
<b>43,7</b>	45,2	0,85	MR ICI 64 - 90 LC *4	32	
<b>42</b>	47	1,32	MR ICI 80 - 90 LC 4	33,3	
<b>42</b>	47	1,5	MR ICI 81 - 90 LC 4	33,3	
<b>43,1</b>	46,8	0,95	MR CI 80 - 90 LC 4	32,5	
<b>43,1</b>	46,8	1,12	MR CI 81 - 90 LC 4	32,5	
<b>43,1</b>	46,8	0,95	MR CI 80 - 100 LA 4	32,5	
<b>43,1</b>	46,8	1,12	MR CI 81 - 100 LA 4	32,5	
<b>43,3</b>	46,6	1,25	MR CI 80 - 112 M 6	20,8	
<b>43,3</b>	46,6	1,4	MR CI 81 - 112 M 6	20,8	
<b>44,6</b>	44,3	3,15	MR ICI 100 - 90 LC 4	31,4	
<b>44,6</b>	44,3	3	MR ICI 100 - 100 LA 4	31,4	
<b>46,5</b>	43,4	2,12	MR CI 100 - 90 LC 4	30,1	
<b>46,5</b>	43,4	2,12	MR CI 100 - 100 LA 4	30,1	
<b>55,5</b>	35,6	0,9	MR ICI 63 - 90 LC 4	25,2	
<b>55,5</b>	35,6	1,06	MR ICI 64 - 90 LC 4	25,2	
<b>56</b>	36	0,9	MR CI 64 - 90 LC 4	25	

1) Leistungen bei Dauerbetrieb S1; bei Betriebsarten S2 ... S10 können sie gesteigert werden (s. Kap. 2b); M<sub>2</sub> steigt und f<sub>s</sub> fällt proportional.  
 2) Zur vollständigen Bestellbezeichnung s. Kap. 3.  
 \* Bauform B5R (s. Tabelle Kap. 2b).

1) Powers valid for continuous duty S1; increase possible for S2 ... S10 (see ch. 2b); in which case M<sub>2</sub> increases and f<sub>s</sub> decreases proportionately.  
 2) For complete designation when ordering see ch. 3.  
 \* Mounting position B5R (see table ch. 2b).

14 - Herstellungsprogramm (Kegelstirnradgetriebemotoren)  
14 - Manufacturing programme (right angle shafts)

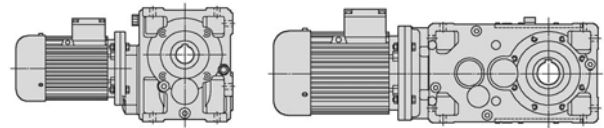

P <sub>1</sub> kW	n <sub>2</sub> min <sup>-1</sup>	M <sub>2</sub> daN m	f <sub>s</sub>	Getriebe - Motor Gear reducer - Motor	i
1)				2)	
<b>2,2</b>	<b>53,3</b>	37,1	1,8	MR ICI 80 - 90 LC 4	26,3
	<b>53,3</b>	37,1	2,12	MR ICI 81 - 90 LC 4	26,3
	<b>53,8</b>	37,5	1,5	MR CI 80 - 90 LC 4	26
	<b>53,8</b>	37,5	1,7	MR CI 81 - 90 LC 4	26
	<b>53,8</b>	37,5	1,5	MR CI 80 - 100 LA 4	26
	<b>53,8</b>	37,5	1,7	MR CI 81 - 100 LA 4	26
	<b>56,6</b>	34,9	4	MR ICI 100 - 100 LA 4	24,7
	<b>67,6</b>	29,2	0,9	MR ICI 63 - 90 LC 4	20,7
	<b>67,6</b>	29,2	1,06	MR ICI 64 - 90 LC 4	20,7
	<b>70</b>	28,8	0,95	MR CI 63 - 90 LC 4	20
	<b>70</b>	28,8	1,12	MR CI 64 - 90 LC 4	20
	<b>70,8</b>	27,9	1,9	MR ICI 80 - 90 LC 4	19,8
	<b>70,8</b>	27,9	2,36	MR ICI 81 - 90 LC 4	19,8
	<b>67,3</b>	30	1,9	MR CI 80 - 90 LC 4	20,8
	<b>67,3</b>	30	2,24	MR CI 81 - 90 LC 4	20,8
	<b>67,3</b>	30	1,9	MR CI 80 - 100 LA 4	20,8
	<b>67,3</b>	30	2,24	MR CI 81 - 100 LA 4	20,8
	<b>67,9</b>	29,1	4,25	MR ICI 100 - 100 LA 4	20,6
	<b>87,5</b>	23,1	1,12	MR CI 63 - 90 LC 4	16
	<b>87,5</b>	23,1	1,4	MR CI 64 - 90 LC 4	16
	<b>84</b>	24	2,5	MR CI 80 - 90 LC 4	16,7
	<b>84</b>	24	2,5	MR CI 80 - 100 LA 4	16,7
	<b>84</b>	24	2,8	MR CI 81 - 100 LA 4	16,7
	<b>111</b>	18,2	1,7	MR CI 63 - 90 LC 4	12,6
	<b>111</b>	18,2	2	MR CI 64 - 90 LC 4	12,6
	<b>107</b>	18,9	3,35	MR CI 80 - 100 LA 4	13,1
	<b>135</b>	14,9	1,6	MR CI 63 - 90 LC 4	10,4
	<b>135</b>	14,9	2	MR CI 64 - 90 LC 4	10,4
	<b>142</b>	14,2	3,75	MR CI 80 - 100 LA 4	9,88
	<b>175</b>	11,5	1,6	MR CI 63 - 90 LC 4	7,98
	<b>175</b>	11,5	2	MR CI 64 - 90 LC 4	7,98
	<b>182</b>	11,1	3,75	MR CI 80 - 100 LA 4	7,71
	<b>222</b>	9,1	1,6	MR CI 63 - 90 LC 4	6,31
	<b>222</b>	9,1	2	MR CI 64 - 90 LC 4	6,31
	<b>227</b>	8,9	3,75	MR CI 80 - 100 LA 4	6,16
<b>3</b>	<b>5,98</b>	451	0,8	MR C2I 140 - 112 MC 6	151
	<b>5,98</b>	451	0,8	MR C2I 140 - 132 S 6	151
	<b>5,85</b>	460	1,18	MR C2I 160 - 112 MC 6	154
	<b>5,85</b>	460	1,18	MR C2I 160 - 132 S 6	154
	<b>5,68</b>	474	1,6	MR C2I 180 - 112 MC 6	158
	<b>5,68</b>	474	1,6	MR C2I 180 - 132 S 6	158
	<b>5,94</b>	453	2,36	MR C2I 200 - 132 S 6	151
	<b>7,33</b>	367	1	MR C2I 140 - 112 MC 6	123
	<b>7,33</b>	367	1	MR C2I 140 - 132 S 6	123
	<b>7,31</b>	368	1,18	MR ICI 160 - 112 MC 6	123
	<b>6,97</b>	387	1,6	MR C2I 160 - 112 MC 6	129
	<b>6,97</b>	387	1,6	MR C2I 160 - 132 S 6	129
	<b>6,93</b>	388	2,12	MR C2I 180 - 112 MC 6	130
	<b>6,93</b>	388	2,12	MR C2I 180 - 132 S 6	130
	<b>7,7</b>	350	2,5	MR ICI 200 - 132 S 6	117
	<b>8,83</b>	298	0,8	MR C3I 125 - 100 LB 4	158
	<b>9,3</b>	290	1,25	MR C2I 140 - 100 LB 4	151
	<b>9,16</b>	294	1,4	MR C2I 140 - 112 MC 6	98,2
	<b>9,16</b>	294	1,4	MR C2I 140 - 132 S 6	98,2
	<b>9,14</b>	295	1,8	MR ICI 160 - 112 MC 6	98,5
	<b>9,1</b>	296	1,8	MR C2I 160 - 100 LB 4	154
	<b>8,71</b>	309	2	MR C2I 160 - 112 MC 6	103
	<b>8,71</b>	309	2	MR C2I 160 - 132 S 6	103
	<b>8,87</b>	304	2	MR ICI 180 - 112 MC 6	101
	<b>8,83</b>	305	2,5	MR C2I 180 - 100 LB 4	158
	<b>9,62</b>	280	4	MR ICI 200 - 132 S 6	93,5
	<b>11</b>	239	1,12	MR C3I 125 - 100 LB 4	127
	<b>11,6</b>	232	0,95	MR ICI 125 - 100 LB *4	121
	<b>11,5</b>	234	1,06	MR ICI 125 - 112 MC 6	78,1
	<b>11,5</b>	234	1,32	MR ICI 140 - 112 MC 6	78,1
	<b>11,4</b>	236	1,5	MR C2I 140 - 100 LB 4	123
	<b>11,4</b>	237	1,8	MR ICI 160 - 100 LB 4	123
	<b>11,5</b>	234	2,24	MR ICI 160 - 112 MC 6	78,1
	<b>10,8</b>	248	2,5	MR C2I 160 - 100 LB 4	129
	<b>11,5</b>	234	4,75	MR ICI 200 - 132 S 6	78,1
	<b>14</b>	188	1,5	MR C3I 125 - 100 LB 4	100
	<b>14,5</b>	185	1,32	MR ICI 125 - 100 LB *4	96,4
	<b>14,3</b>	188	1,18	MR ICI 125 - 100 LB 4	97,7
	<b>14,2</b>	190	1,32	MR ICI 125 - 112 MC 6	63,4

P <sub>1</sub> kW	n <sub>2</sub> min <sup>-1</sup>	M <sub>2</sub> daN m	f <sub>s</sub>	Getriebe - Motor Gear reducer - Motor	i
1)				2)	
<b>3</b>	<b>14,2</b>	190	1,12	MR ICI 125 - 132 S 6	63,4
	<b>14,5</b>	185	1,6	MR ICI 140 - 100 LB *4	96,4
	<b>14,2</b>	190	1,6	MR ICI 140 - 112 MC 6	63,4
	<b>14,3</b>	189	2,24	MR C2I 140 - 100 LB 4	98,2
	<b>14,2</b>	189	2,8	MR ICI 160 - 100 LB 4	98,5
	<b>16</b>	169	2,5	MR C2I 140 - 100 LB 4	87,8
	<b>18,7</b>	144	0,85	MR ICI 100 - 112 MC 6	48,2
	<b>17,9</b>	150	1,6	MR ICI 125 - 100 LB 4	78,1
	<b>17,9</b>	150	2	MR ICI 140 - 100 LB 4	78,1
	<b>17,7</b>	152	2,36	MR ICI 140 - 112 MC 6	50,7
	<b>17,7</b>	152	1,9	MR ICI 140 - 132 S 6	50,8
	<b>17,8</b>	151	2,8	MR C2I 140 - 100 LB 4	78,6
	<b>17,9</b>	150	3,55	MR ICI 160 - 100 LB 4	78,1
	<b>19,9</b>	135	3,15	MR C2I 140 - 100 LB 4	70,2
	<b>22,9</b>	118	1,06	MR ICI 100 - 100 LB *4	61,2
	<b>23,2</b>	116	0,8	MR ICI 100 - 100 LB 4	60,2
	<b>23,3</b>	115	1,06	MR ICI 100 - 112 MC 6	38,5
	<b>24,6</b>	112	0,9	MR CI 100 - 112 MC 6	36,6
	<b>22,1</b>	122	2	MR ICI 125 - 100 LB 4	63,4
	<b>22,6</b>	119	3,55	MR C2I 140 - 100 LB 4	62
	<b>25,3</b>	106	4	MR C2I 140 - 100 LB 4	55,4
	<b>29,1</b>	93	1,32	MR ICI 100 - 100 LB 4	48,2
	<b>29,9</b>	92	1	MR CI 100 - 112 MC 6	30,1
	<b>29,9</b>	92	1	MR CI 100 - 132 S 6	30,1
	<b>27,6</b>	98	2,5	MR ICI 125 - 100 LB 4	50,7
	<b>28,8</b>	96	1,9	MR CI 125 - 132 S 6	31,3
	<b>27,8</b>	97	4,25	MR C2I 140 - 100 LB 4	50,4
	<b>33,7</b>	80	0,85	MR ICI 81 - 100 LB 4	41,6
	<b>34,6</b>	79	0,85	MR CI 81 - 112 MC 6	26
	<b>36,3</b>	74	1,6	MR ICI 100 - 100 LB 4	38,5
	<b>38,2</b>	72	1,32	MR CI 100 - 100 LB 4	36,6
	<b>37,4</b>	74	1,5	MR CI 100 - 112 MC 6	24,1
	<b>37,4</b>	74	1,5	MR CI 100 - 132 S 6	24,1
	<b>34,5</b>	78	3,55	MR ICI 125 - 100 LB 4	40,6
	<b>36</b>	76	3,15	MR CI 125 - 132 S 6	25
	<b>42</b>	64	0,95	MR ICI 80 - 100 LB 4	33,3
	<b>42</b>	64	1,06	MR ICI 81 - 100 LB 4	33,3
	<b>43,1</b>	64	0,8	MR CI 81 - 100 LB 4	32,5
	<b>43,3</b>	64	0,9	MR CI 80 - 112 MC 6	20,8
	<b>43,3</b>	64	1,06	MR CI 81 - 112 MC 6	20,8
	<b>44,6</b>	60	2,12	MR ICI 100 - 100 LB 4	31,4
	<b>46,5</b>	59	1,5	MR CI 100 - 100 LB 4	30,1
	<b>46,7</b>	59	2	MR CI 100 - 112 MC 6	19,3
	<b>46,7</b>	59	2	MR CI 100 - 132 S 6	19,3
	<b>45</b>	61	4	MR CI 125 - 132 S 6	20
	<b>53,3</b>	51	1,32	MR ICI 80 - 100 LB 4	26,3
	<b>53,3</b>	51	1,5	MR ICI 81 - 100 LB 4	26,3
	<b>53,8</b>	51	1,12	MR CI 80 - 100 LB 4	26
	<b>53,8</b>	51	1,25	MR CI 81 - 100 LB 4	26
	<b>56,6</b>	47,6	3	MR ICI 100 - 100 LB 4	24,7
	<b>58,1</b>	47,3	2,24	MR CI 100 - 100 LB 4	24,1
	<b>70</b>	39,3	0,85	MR CI 64 - 100 LB 4	20
	<b>70,8</b>	38	1,4	MR ICI 80 - 100 LB 4	19,8
	<b>70,8</b>	38	1,7	MR ICI 81 - 100 LB 4	19,8
	<b>67,3</b>	40,9	1,4	MR CI 80 - 100 LB 4	20,8
	<b>67,3</b>	40,9	1,6	MR CI 81 - 100 LB 4	20,8
	<b>67,9</b>	39,6	3,15	MR ICI 100 - 100 LB 4	20,6
	<b>72,6</b>	37,9	3,15	MR CI 100 - 100 LB 4	19,3
	<b>87,5</b>	31,4	1	MR CI 64 - 100 LB 4	16
	<b>84</b>	32,7	1,8	MR CI 80 - 100 LB 4	16,7
	<b>84</b>	32,7	2	MR CI 81 - 100 LB 4	16,7
	<b>89,2</b>	30,8	3,55	MR CI 100 - 100 LB 4	15,7
	<b>111</b>	24,8	1,5	MR CI 64 - 100 LB 4	12,6
	<b>107</b>	25,8	2,5	MR CI 80 - 100 LB 4	13,1
	<b>113</b>	24,3	5,3	MR CI 100 - 100 LB 4	12,4
	<b>135</b>	20,4	1,5	MR CI 64 - 100 LB 4	10,4
	<b>142</b>	19,4	2,65	MR CI 80 - 100 LB 4	9,88
	<b>175</b>	15,7	1,5	MR CI 64 - 100 LB 4	7,98
	<b>182</b>	15,1	2,65	MR CI 80 - 100 LB 4	7,71
	<b>222</b>	12,4	1,5	MR CI 64 - 100 LB 4	6,31
	<b>227</b>	12,1	2,65	MR CI 80 - 100 LB 4	6,16
<b>4</b>	<b>5,85</b>	614	0,85	MR C2I 160 - 132 M 6	154

1) Leistungen bei Dauerbetrieb S1; bei Betriebsarten S2 ... S10 können sie **gesteigert** werden (s. Kap. 2b); M<sub>2</sub> steigt und f<sub>s</sub> fällt proportional.  
2) Zur vollständigen Bestellbezeichnung s. Kap. 3.  
\* Bauform **B5R** (s. Tabelle Kap. 2b).

1) Powers valid for continuous duty S1; **increase** possible for S2 ... S10 (see ch. 2b); in which case M<sub>2</sub> increases and f<sub>s</sub> decreases proportionately.  
2) For complete designation when ordering see ch. 3.  
\* Mounting position **B5R** (see table ch. 2b).

14 - Herstellungsprogramm (Kegelstirnradgetriebemotoren)  
 14 - Manufacturing programme (right angle shafts)

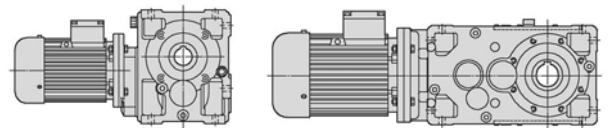

P <sub>1</sub>	n <sub>2</sub>	M <sub>2</sub>	f <sub>s</sub>	Getriebe - Motor Gear reducer - Motor	i
1)	min <sup>-1</sup>	daN m		2)	
<b>4</b>	<b>5,68</b>	632	1,18	MR C2I 180 - 132 M 6	158
	<b>5,94</b>	604	1,8	MR C2I 200 - 132 M 6	151
	<b>5,77</b>	623	2,36	MR C2I 225 - 132 M 6	156
	<b>6,97</b>	515	1,18	MR C2I 160 - 132 M 6	129
	<b>6,93</b>	518	1,6	MR C2I 180 - 132 M 6	130
	<b>7,7</b>	466	1,9	MR ICI 200 - 132 M 6	117
	<b>7,08</b>	507	2,5	MR C2I 200 - 132 M 6	127
	<b>9,3</b>	386	0,9	MR C2I 140 - 112 M 4	151
	<b>9,16</b>	392	1,06	MR C2I 140 - 132 M 6	98,2
	<b>9,1</b>	395	1,32	MR C2I 160 - 112 M 4	154
	<b>8,83</b>	406	1,8	MR C2I 180 - 112 M 4	158
	<b>9,62</b>	373	3	MR ICI 200 - 132 M 6	93,5
	<b>11</b>	318	0,85	MR C3I 125 - 112 M 4	127
	<b>11,4</b>	315	1,12	MR C2I 140 - 112 M 4	123
	<b>11,4</b>	316	1,4	MR ICI 160 - 112 M 4	123
	<b>10,8</b>	331	1,9	MR C2I 160 - 112 M 4	129
	<b>11,5</b>	312	3,55	MR ICI 200 - 132 M 6	78,1
	<b>14</b>	251	1,12	MR C3I 125 - 112 M 4	100
	<b>14,5</b>	247	1	MR ICI 125 - 112 M *4	96,4
	<b>14,3</b>	250	0,85	MR ICI 125 - 112 M 4	97,7
	<b>14,5</b>	247	1,18	MR ICI 140 - 112 M *4	96,4
	<b>14,3</b>	252	1,6	MR C2I 140 - 112 M 4	98,2
	<b>14,2</b>	253	2,12	MR ICI 160 - 112 M 4	98,5
	<b>13,5</b>	265	2,36	MR C2I 160 - 112 M 4	103
	<b>13,8</b>	260	2,36	MR ICI 180 - 112 M 4	101
	<b>16</b>	225	1,9	MR C2I 140 - 112 M 4	87,8
	<b>15,5</b>	232	2,65	MR C2I 160 - 112 M 4	90,4
	<b>17,9</b>	200	1,18	MR ICI 125 - 112 M 4	78,1
	<b>17,9</b>	200	1,5	MR ICI 140 - 112 M 4	78,1
	<b>17,7</b>	203	1,5	MR ICI 140 - 132 M 6	50,8
	<b>17,8</b>	202	2	MR C2I 140 - 112 M 4	78,6
	<b>17,9</b>	200	2,65	MR ICI 160 - 112 M 4	78,1
	<b>19,9</b>	180	2,36	MR C2I 140 - 112 M 4	70,2
	<b>22,9</b>	157	0,8	MR ICI 100 - 112 M *4	61,2
	<b>22,1</b>	163	1,5	MR ICI 125 - 112 M 4	63,4
	<b>22,1</b>	163	1,8	MR ICI 140 - 112 M 4	63,4
	<b>22,6</b>	159	2,65	MR C2I 140 - 112 M 4	62
	<b>22,4</b>	160	3,35	MR ICI 160 - 112 M 4	62,5
	<b>25,3</b>	142	3	MR C2I 140 - 112 M 4	55,4
	<b>29,1</b>	124	1	MR ICI 100 - 112 M 4	48,2
	<b>27,6</b>	130	1,9	MR ICI 125 - 112 M 4	50,7
	<b>28,8</b>	127	1,4	MR CI 125 - 132 M 6	31,3
	<b>27,6</b>	130	2,8	MR ICI 140 - 112 M 4	50,7
	<b>27,8</b>	129	3,15	MR C2I 140 - 112 M 4	50,4
	<b>36,3</b>	99	1,25	MR ICI 100 - 112 M 4	38,5
	<b>38,2</b>	96	1	MR CI 100 - 112 M 4	36,6
	<b>37,4</b>	98	1,12	MR CI 100 - 132 M 6	24,1
	<b>34,5</b>	104	2,65	MR ICI 125 - 112 M 4	40,6
	<b>36</b>	102	2,36	MR CI 125 - 132 M 6	25
	<b>44,6</b>	80	1,6	MR ICI 100 - 112 M 4	31,4
	<b>46,5</b>	79	1,12	MR CI 100 - 112 M 4	30,1
	<b>46,7</b>	79	1,5	MR CI 100 - 132 M 6	19,3
	<b>43,8</b>	82	3,35	MR ICI 125 - 112 M 4	32
	<b>45</b>	81	3	MR CI 125 - 132 M 6	20
	<b>53,8</b>	68	0,85	MR CI 80 - 112 M 4	26
	<b>53,8</b>	68	0,95	MR CI 81 - 112 M 4	26
	<b>56,6</b>	63	2,24	MR ICI 100 - 112 M 4	24,7
	<b>58,1</b>	63	1,7	MR CI 100 - 112 M 4	24,1
	<b>53,3</b>	67	4,25	MR ICI 125 - 112 M 4	26,3
	<b>56,3</b>	65	3,75	MR CI 125 - 132 M 6	16
	<b>67,3</b>	54	1,06	MR CI 80 - 112 M 4	20,8
<b>67,3</b>	54	1,18	MR CI 81 - 112 M 4	20,8	
<b>67,9</b>	53	2,36	MR ICI 100 - 112 M 4	20,6	
<b>72,6</b>	50	2,36	MR CI 100 - 112 M 4	19,3	
<b>84</b>	43,7	1,32	MR CI 80 - 112 M 4	16,7	
<b>84</b>	43,7	1,5	MR CI 81 - 112 M 4	16,7	
<b>89,2</b>	41,1	2,65	MR CI 100 - 112 M 4	15,7	
<b>107</b>	34,4	1,9	MR CI 80 - 112 M 4	13,1	
<b>107</b>	34,4	2,24	MR CI 81 - 112 M 4	13,1	
<b>113</b>	32,4	4	MR CI 100 - 112 M 4	12,4	
<b>142</b>	25,9	2	MR CI 80 - 112 M 4	9,88	
<b>142</b>	25,9	2,5	MR CI 81 - 112 M 4	9,88	

P <sub>1</sub>	n <sub>2</sub>	M <sub>2</sub>	f <sub>s</sub>	Getriebe - Motor Gear reducer - Motor	i
1)	min <sup>-1</sup>	daN m		2)	
<b>4</b>	<b>182</b>	20,2	2	MR CI 80 - 112 M 4	7,71
	<b>182</b>	20,2	2,5	MR CI 81 - 112 M 4	7,71
<b>5,5</b>	<b>227</b>	16,1	2	MR CI 80 - 112 M 4	6,16
	<b>227</b>	16,1	2,5	MR CI 81 - 112 M 4	6,16
	<b>5,68</b>	869	0,85	MR C2I 180 - 132 MB 6	158
	<b>5,94</b>	831	1,32	MR C2I 200 - 132 MB 6	151
	<b>5,77</b>	856	1,8	MR C2I 225 - 132 MB 6	156
	<b>6,97</b>	709	0,85	MR C2I 160 - 132 MB 6	129
	<b>6,93</b>	712	1,18	MR C2I 180 - 132 MB 6	130
	<b>7,7</b>	641	1,32	MR ICI 200 - 132 MB 6	117
	<b>7,08</b>	698	1,8	MR C2I 200 - 132 MB 6	127
	<b>7,18</b>	687	2,36	MR C2I 225 - 132 MB 6	125
	<b>9,1</b>	543	1	MR C2I 160 - 112 MC 4	154
	<b>9,1</b>	543	1	MR C2I 160 - 132 S 4	154
	<b>8,83</b>	559	1,32	MR C2I 180 - 112 MC 4	158
	<b>8,83</b>	559	1,32	MR C2I 180 - 132 S 4	158
	<b>8,67</b>	570	1,5	MR C2I 180 - 132 MB 6	104
	<b>9,62</b>	513	2,12	MR ICI 200 - 132 MB 6	93,5
<b>9,24</b>	534	2	MR C2I 200 - 132 S 4	151	
<b>8,97</b>	550	2,8	MR C2I 225 - 132 S 4	156	
<b>10,3</b>	481	0,9	MR C2I 140 - 132 MB 6	87,8	
<b>11,4</b>	433	0,85	MR C2I 140 - 112 MC 4	123	
<b>11,4</b>	433	0,85	MR C2I 140 - 132 S 4	123	
<b>11,5</b>	431	0,95	MR C2I 140 - 132 MB 6	78,6	
<b>11,4</b>	434	1	MR ICI 160 - 112 MC 4	123	
<b>11,4</b>	431	1	MR ICI 160 - 132 MB 6	78,6	
<b>10,8</b>	456	1,32	MR C2I 160 - 112 MC 4	129	
<b>10,8</b>	456	1,32	MR C2I 160 - 132 S 4	129	
<b>10,8</b>	458	1,7	MR C2I 180 - 112 MC 4	130	
<b>10,8</b>	458	1,7	MR C2I 180 - 132 S 4	130	
<b>12</b>	412	2,12	MR ICI 200 - 132 S 4	117	
<b>11</b>	449	2,8	MR C2I 200 - 132 S 4	127	
<b>14,3</b>	346	1,18	MR C2I 140 - 112 MC 4	98,2	
<b>14,3</b>	346	1,18	MR C2I 140 - 132 S 4	98,2	
<b>14,2</b>	347	1,5	MR ICI 160 - 112 MC 4	98,5	
<b>14,3</b>	345	1,5	MR ICI 160 - 132 MB 6	62,9	
<b>13,5</b>	364	1,7	MR C2I 160 - 112 MC 4	103	
<b>13,5</b>	364	1,7	MR C2I 160 - 132 S 4	103	
<b>13,8</b>	358	1,7	MR ICI 180 - 112 MC 4	101	
<b>13,9</b>	355	1,7	MR ICI 180 - 132 MB 6	64,8	
<b>13,5</b>	366	2,36	MR C2I 180 - 132 S 4	104	
<b>15</b>	330	3,35	MR ICI 200 - 132 S 4	93,5	
<b>16</b>	310	1,4	MR C2I 140 - 112 MC 4	87,8	
<b>16</b>	310	1,4	MR C2I 140 - 132 S 4	87,8	
<b>15,5</b>	319	2	MR C2I 160 - 112 MC 4	90,4	
<b>15,5</b>	319	2	MR C2I 160 - 132 S 4	90,4	
<b>17,9</b>	276	0,9	MR ICI 125 - 112 MC 4	78,1	
<b>17,7</b>	278	0,85	MR ICI 125 - 132 MB 6	50,8	
<b>17,9</b>	276	1,06	MR ICI 140 - 112 MC 4	78,1	
<b>17,7</b>	278	1,06	MR ICI 140 - 132 MB 6	50,8	
<b>17,8</b>	277	1,5	MR C2I 140 - 112 MC 4	78,6	
<b>17,8</b>	277	1,5	MR C2I 140 - 132 S 4	78,6	
<b>17,9</b>	276	1,9	MR ICI 160 - 112 MC 4	78,1	
<b>17,8</b>	277	1,5	MR ICI 160 - 132 S 4	78,6	
<b>16,9</b>	292	2,12	MR C2I 160 - 132 S 4	82,7	
<b>17,4</b>	284	2,12	MR ICI 180 - 112 MC 4	80,5	
<b>17,4</b>	284	2,65	MR ICI 180 - 132 MB 6	51,8	
<b>17,9</b>	276	4	MR ICI 200 - 132 S 4	78,1	
<b>19,9</b>	248	1,7	MR C2I 140 - 112 MC 4	70,2	
<b>19,9</b>	248	1,7	MR C2I 140 - 132 S 4	70,2	
<b>19,4</b>	255	2,5	MR C2I 160 - 132 S 4	72,3	
<b>22,1</b>	224	1,06	MR ICI 125 - 112 MC 4	63,4	
<b>22,1</b>	224	0,95	MR ICI 125 - 132 S 4	63,4	
<b>22,2</b>	223	1,12	MR ICI 125 - 132 MB 6	40,6	
<b>22,1</b>	224	1,32	MR ICI 140 - 112 MC 4	63,4	
<b>22,2</b>	223	1,6	MR ICI 140 - 132 MB 6	40,6	
<b>22,6</b>	218	1,9	MR C2I 140 - 112 MC 4	62	
<b>22,6</b>	218	1,9	MR C2I 140 - 132 S 4	62	
<b>22,3</b>	222	2,36	MR ICI 160 - 132 S 4	62,9	
<b>21,5</b>	230	2,65	MR C2I 160 - 132 S 4	65,2	
<b>25,3</b>	195	2,12	MR C2I 140 - 132 S 4	55,4	
<b>27,6</b>	179	1,32	MR ICI 125 - 112 MC 4	50,7	
<b>27,6</b>	179	1,32	MR ICI 125 - 132 S 4	50,8	

1) Leistungen bei Dauerbetrieb S1; bei Betriebsarten S2 ... S10 können sie **gesteigert** werden (s. Kap. 2b); M<sub>2</sub> steigt und f<sub>s</sub> fällt proportional.  
 2) Zur vollständigen Bestellbezeichnung s. Kap. 3.  
 \* Bauform **B5R** (s. Tabelle Kap. 2b).

1) Powers valid for continuous duty S1; **increase** possible for S2 ... S10 (see ch. 2b); in which case M<sub>2</sub> increases and f<sub>s</sub> decreases proportionately.  
 2) For complete designation when ordering see ch. 3.  
 \* Mounting position **B5R** (see table ch. 2b).

14 - Herstellungsprogramm (Kegelstirnradgetriebemotoren)  
14 - Manufacturing programme (right angle shafts)

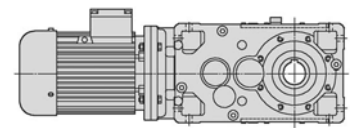
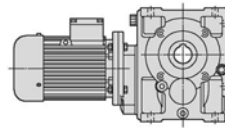

$P_1$ kW	$n_2$ min <sup>-1</sup>	$M_2$ daN m	$f_s$	Getriebe - Motor Gear reducer - Motor	$i$
1)				2)	
5,5	28,8	175	1,06	MR CI 125 - 132 MB 6	31,3
	27,6	179	2	MR ICI 140 - 112 MC 4	50,7
	27,6	179	1,6	MR ICI 140 - 132 S 4	50,8
	28,1	176	2	MR ICI 140 - 132 MB 6	32
	27,8	178	2,36	MR C2I 140 - 132 S 4	50,4
	27,8	177	3	MR ICI 160 - 132 S 4	50,3
	31,1	159	2,65	MR C2I 140 - 132 S 4	45,1
	36,3	136	0,9	MR ICI 100 - 112 MC 4	38,5
	37,4	135	0,8	MR CI 100 - 132 MB 6	24,1
	34,5	143	2	MR ICI 125 - 112 MC 4	40,6
	34,5	143	1,7	MR ICI 125 - 132 S 4	40,6
	36	140	1,7	MR CI 125 - 132 MB 6	25
	35	141	2,5	MR ICI 140 - 112 MC 4	40
	34,5	143	2,5	MR ICI 140 - 132 S 4	40,6
	36,2	136	3	MR C2I 140 - 132 S 4	38,7
	37,3	132	3,15	MR C2I 140 - 132 S 4	37,5
	44,6	111	1,18	MR ICI 100 - 112 MC 4	31,4
	46,5	108	0,85	MR CI 100 - 112 MC 4	30,1
	46,5	108	0,85	MR CI 100 - 132 S 4	30,1
	46,7	108	1,12	MR CI 100 - 132 MB 6	19,3
	43,1	115	2,5	MR ICI 125 - 132 S 4	32,5
	44,8	113	1,5	MR CI 125 - 132 S 4	31,3
	45	112	2,12	MR CI 125 - 132 MB 6	20
	43,5	114	3,15	MR C2I 140 - 132 S 4	32,2
	56,6	87	1,6	MR ICI 100 - 112 MC 4	24,7
	58,1	87	1,25	MR CI 100 - 112 MC 4	24,1
	58,1	87	1,25	MR CI 100 - 132 S 4	24,1
	54,7	90	3	MR ICI 125 - 132 S 4	25,6
	56	90	2,65	MR CI 125 - 132 S 4	25
	67,3	75	0,9	MR CI 81 - 112 MC 4	20,8
	67,9	73	1,7	MR ICI 100 - 112 MC 4	20,6
	72,6	69	1,7	MR CI 100 - 112 MC 4	19,3
	72,6	69	1,7	MR CI 100 - 132 S 4	19,3
	66,5	74	3,75	MR ICI 125 - 132 S 4	21
	70	72	3,35	MR CI 125 - 132 S 4	20
	84	60	1	MR CI 80 - 112 MC 4	16,7
	84	60	1,12	MR CI 81 - 112 MC 4	16,7
	89,2	57	2	MR CI 100 - 112 MC 4	15,7
	89,2	57	2	MR CI 100 - 132 S 4	15,7
	87,5	58	4,25	MR CI 125 - 132 S 4	16
	107	47,3	1,4	MR CI 80 - 112 MC 4	13,1
	107	47,3	1,6	MR CI 81 - 112 MC 4	13,1
	113	44,6	2,8	MR CI 100 - 112 MC 4	12,4
	113	44,6	2,8	MR CI 100 - 132 S 4	12,4
	142	35,6	1,5	MR CI 80 - 112 MC 4	9,88
	142	35,6	1,8	MR CI 81 - 112 MC 4	9,88
	136	37,1	2,8	MR CI 100 - 112 MC 4	10,3
	136	37,1	2,8	MR CI 100 - 132 S 4	10,3
	182	27,8	1,5	MR CI 80 - 112 MC 4	7,71
	182	27,8	1,8	MR CI 81 - 112 MC 4	7,71
	174	29	2,8	MR CI 100 - 132 S 4	8,06
	227	22,2	1,5	MR CI 80 - 112 MC 4	6,16
	227	22,2	1,8	MR CI 81 - 112 MC 4	6,16
	217	23,3	2,8	MR CI 100 - 132 S 4	6,46
7,5	5,94	1133	0,95	MR C2I 200 - 132 MC 6	151
	5,94	1133	0,95	MR C2I 200 - 160 M 6	151
	5,77	1167	1,32	MR C2I 225 - 132 MC 6	156
	5,77	1167	1,32	MR C2I 225 - 160 M 6	156
	5,76	1169	1,9	MR C2I 250 - 160 M 6	156
	5,85	1151	2,65	MR C2I 280 - 160 M 6	154
	6,93	971	0,85	MR C2I 180 - 132 MC 6	130
	6,93	971	0,85	MR C2I 180 - 160 M 6	130
	7,7	875	1	MR ICI 200 - 132 MC 6	117
	7,08	951	1,32	MR C2I 200 - 132 MC 6	127
	7,08	951	1,32	MR C2I 200 - 160 M 6	127
	7,18	937	1,7	MR C2I 225 - 132 MC 6	125
	7,18	937	1,7	MR C2I 225 - 160 M 6	125
	7,31	921	2,65	MR C2I 250 - 160 M 6	123
	8,83	762	1	MR C2I 180 - 132 M 4	158
	8,67	777	1,12	MR C2I 180 - 132 MC 6	104
	8,67	777	1,12	MR C2I 180 - 160 M 6	104
	9,62	700	1,6	MR ICI 200 - 132 MC 6	93,5
	9,22	731	1,18	MR ICI 200 - 160 M 6	97,7

$P_1$ kW	$n_2$ min <sup>-1</sup>	$M_2$ daN m	$f_s$	Getriebe - Motor Gear reducer - Motor	$i$
1)				2)	
7,5	9,24	728	1,5	MR C2I 200 - 132 M 4	151
	8,97	750	2	MR C2I 225 - 132 M 4	156
	9,96	676	0,95	MR C2I 160 - 132 MC 6	90,4
	9,96	676	0,95	MR C2I 160 - 160 M 6	90,4
	10,8	621	1	MR C2I 160 - 132 M 4	129
	10,8	624	1,25	MR C2I 180 - 132 M 4	130
	12	562	1,5	MR ICI 200 - 132 M 4	117
	11,5	584	1,9	MR ICI 200 - 132 MC 6	78,1
	11,5	584	1,9	MR ICI 200 - 160 M 6	78,1
	11	612	2	MR C2I 200 - 132 M 4	127
	12,8	525	0,8	MR C2I 140 - 132 MC 6	70,2
	14,3	472	0,85	MR C2I 140 - 132 M 4	98,2
	14,2	474	1,12	MR ICI 160 - 132 M *4	98,5
	14,3	471	1,12	MR ICI 160 - 132 MC 6	62,9
	14,3	471	1,12	MR ICI 160 - 160 M 6	62,9
	13,5	497	1,25	MR C2I 160 - 132 M 4	103
	13,8	488	1,25	MR ICI 180 - 132 M *4	101
	13,9	485	1,25	MR ICI 180 - 132 MC 6	64,8
	13,9	485	1,25	MR ICI 180 - 160 M 6	64,8
	13,5	499	1,8	MR C2I 180 - 132 M 4	104
	15	450	2,36	MR ICI 200 - 132 M 4	93,5
	13,8	489	2,5	MR C2I 200 - 132 M 4	102
	16	422	1	MR C2I 140 - 132 M 4	87,8
	15,5	435	1,4	MR C2I 160 - 132 M 4	90,4
	15,6	433	1,9	MR C2I 180 - 132 M 4	90
	15,9	423	3	MR C2I 200 - 132 M 4	87,9
	17,9	376	0,8	MR ICI 140 - 132 M *4	78,1
	17,7	380	0,8	MR ICI 140 - 132 MC 6	50,8
	17,8	378	1,12	MR C2I 140 - 132 M 4	78,6
	17,9	376	1,4	MR ICI 160 - 132 M *4	78,1
	17,8	378	1,12	MR ICI 160 - 132 M 4	78,6
	17,9	376	1,4	MR ICI 160 - 132 MC 6	50,3
	18,3	368	1,4	MR ICI 160 - 160 M 6	49,2
	16,9	398	1,5	MR C2I 160 - 132 M 4	82,7
	17,4	387	1,5	MR ICI 180 - 132 M *4	80,5
	17,4	388	1,9	MR ICI 180 - 132 MC 6	51,8
	17,7	379	1,6	MR ICI 180 - 160 M 6	50,7
	16,9	400	2,24	MR C2I 180 - 132 M 4	83,1
	17,9	376	3	MR ICI 200 - 132 M 4	78,1
	19,9	338	1,25	MR C2I 140 - 132 M 4	70,2
	19,4	348	1,8	MR C2I 160 - 132 M 4	72,3
	19,4	346	2,36	MR C2I 180 - 132 M 4	72,7
	22,1	305	0,8	MR ICI 125 - 132 M *4	63,4
	22,2	304	0,8	MR ICI 125 - 132 MC 6	40,6
	22,1	305	0,95	MR ICI 140 - 132 M *4	63,4
	22,2	304	1,18	MR ICI 140 - 132 MC 6	40,6
	22,6	298	1,4	MR C2I 140 - 132 M 4	62
	22,3	303	1,8	MR ICI 160 - 132 M 4	62,9
	21,5	313	2	MR C2I 160 - 132 M 4	65,2
	21,7	310	2,36	MR ICI 180 - 132 M *4	64,4
	21,6	312	1,9	MR ICI 180 - 132 M 4	64,8
	22,4	301	3,55	MR ICI 200 - 132 M 4	62,5
	25,3	266	1,6	MR C2I 140 - 132 M 4	55,4
	24,6	274	2,24	MR C2I 160 - 132 M 4	57
	27,6	244	1	MR ICI 125 - 132 M 4	50,8
	27,7	243	1,18	MR ICI 125 - 132 MC 6	32,5
	27,6	244	1,5	MR ICI 140 - 132 M *4	50,7
	27,6	244	1,18	MR ICI 140 - 132 M 4	50,8
	28,1	240	1,5	MR ICI 140 - 132 MC 6	32
	27,8	243	1,7	MR C2I 140 - 132 M 4	50,4
	27,8	242	2,24	MR ICI 160 - 132 M 4	50,3
	26,8	251	2,5	MR C2I 160 - 132 M 4	52,1
	29,3	235	1,5	MR CI 160 - 160 M 6	30,8
	31,1	217	2	MR C2I 140 - 132 M 4	45,1
	34,5	195	1,25	MR ICI 125 - 132 M 4	40,6
	35,1	192	1,5	MR ICI 125 - 132 MC 6	25,6
	36	191	1,25	MR CI 125 - 132 MC 6	25
	36	191	1,25	MR CI 125 - 160 M 6	25
	34,5	195	1,8	MR ICI 140 - 132 M 4	40,6
	36,2	186	2,24	MR C2I 140 - 132 M 4	38,7
	33,1	203	3	MR ICI 160 - 132 M 4	42,3
	36,6	188	2,65	MR CI 160 - 160 M 6	24,6
	37,3	180	2,36	MR C2I 140 - 132 M 4	37,5

1) Leistungen bei Dauerbetrieb S1; bei Betriebsarten S2 ... S10 können sie gesteigert werden (s. Kap. 2b);  $M_2$  steigt und  $f_s$  fällt proportional.  
2) Zur vollständigen Bestellbezeichnung s. Kap. 3.  
\* Bauform B5R (s. Tabelle Kap. 2b).

1) Powers valid for continuous duty S1; increase possible for S2 ... S10 (see ch. 2b); in which case  $M_2$  increases and  $f_s$  decreases proportionately.  
2) For complete designation when ordering see ch. 3.  
\* Mounting position B5R (see table ch. 2b).

14 - Herstellungsprogramm (Kegelstirnradtriebemotoren)  
14 - Manufacturing programme (right angle shafts)

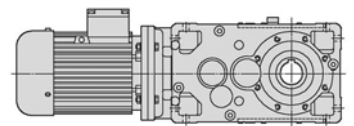
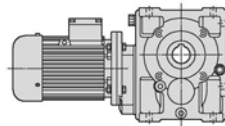

$P_1$ kW	$n_2$ min <sup>-1</sup>	$M_2$ daN m	$f_s$	Getriebe - Motor Gear reducer - Motor	$i$
1)				2)	
<b>7,5</b>	<b>46,7</b>	147	0,8	<b>MR CI 100 - 132 MC 6</b>	19,3
	<b>43,1</b>	156	1,8	<b>MR ICI 125 - 132 M 4</b>	32,5
	<b>44,8</b>	153	1,12	<b>MR CI 125 - 132 M 4</b>	31,3
	<b>45</b>	153	1,6	<b>MR CI 125 - 132 MC 6</b>	20
	<b>45</b>	153	1,6	<b>MR CI 125 - 160 M 6</b>	20
	<b>43,7</b>	154	2,24	<b>MR ICI 140 - 132 M 4</b>	32
	<b>43,5</b>	155	2,36	<b>MR C2I 140 - 132 M 4</b>	32,2
	<b>45</b>	153	2,24	<b>MR CI 140 - 132 MC 6</b>	20
	<b>45</b>	153	2,24	<b>MR CI 140 - 160 M 6</b>	20
	<b>45,7</b>	150	3,55	<b>MR CI 160 - 160 M 6</b>	19,7
	<b>50</b>	138	2,5	<b>MR CI 140 - 132 MC 6</b>	18
	<b>50</b>	138	2,5	<b>MR CI 140 - 160 M 6</b>	18
	<b>58,1</b>	118	0,9	<b>MR CI 100 - 132 M 4</b>	24,1
	<b>54,7</b>	123	2,24	<b>MR ICI 125 - 132 M 4</b>	25,6
	<b>56</b>	123	1,9	<b>MR CI 125 - 132 M 4</b>	25
	<b>72,6</b>	95	1,25	<b>MR CI 100 - 132 M 4</b>	19,3
	<b>66,5</b>	101	2,65	<b>MR ICI 125 - 132 M 4</b>	21
	<b>70</b>	98	2,36	<b>MR CI 125 - 132 M 4</b>	20
	<b>89,2</b>	77	1,4	<b>MR CI 100 - 132 M 4</b>	15,7
	<b>87,5</b>	79	3	<b>MR CI 125 - 132 M 4</b>	16
	<b>113</b>	61	2,12	<b>MR CI 100 - 132 M 4</b>	12,4
<b>111</b>	62	4,25	<b>MR CI 125 - 132 M 4</b>	12,6	
<b>136</b>	51	2,12	<b>MR CI 100 - 132 M 4</b>	10,3	
<b>135</b>	51	4,5	<b>MR CI 125 - 132 M 4</b>	10,4	
<b>174</b>	39,6	2,12	<b>MR CI 100 - 132 M 4</b>	8,06	
<b>175</b>	39,2	4,5	<b>MR CI 125 - 132 M 4</b>	7,98	
<b>217</b>	31,7	2,12	<b>MR CI 100 - 132 M 4</b>	6,46	
<b>222</b>	31	4,5	<b>MR CI 125 - 132 M 4</b>	6,31	
<b>9,2</b>	<b>9,24</b>	894	1,18	<b>MR C2I 200 - 132 MB 4</b>	151
	<b>8,97</b>	921	1,6	<b>MR C2I 225 - 132 MB 4</b>	156
	<b>10,8</b>	766	1,06	<b>MR C2I 180 - 132 MB 4</b>	130
	<b>12</b>	690	1,25	<b>MR ICI 200 - 132 MB 4</b>	117
	<b>11</b>	750	1,7	<b>MR C2I 200 - 132 MB 4</b>	127
	<b>11,2</b>	739	2,12	<b>MR C2I 225 - 132 MB 4</b>	125
	<b>13,5</b>	610	1	<b>MR C2I 160 - 132 MB 4</b>	103
	<b>13,5</b>	613	1,4	<b>MR C2I 180 - 132 MB 4</b>	104
	<b>15</b>	552	2	<b>MR ICI 200 - 132 MB 4</b>	93,5
	<b>13,8</b>	600	2,12	<b>MR C2I 200 - 132 MB 4</b>	102
	<b>16</b>	518	0,8	<b>MR C2I 140 - 132 MB 4</b>	87,8
	<b>15,5</b>	533	1,18	<b>MR C2I 160 - 132 MB 4</b>	90,4
	<b>15,6</b>	531	1,6	<b>MR C2I 180 - 132 MB 4</b>	90
	<b>15,9</b>	519	2,5	<b>MR C2I 200 - 132 MB 4</b>	87,9
	<b>17,8</b>	464	0,9	<b>MR C2I 140 - 132 MB 4</b>	78,6
	<b>17,8</b>	464	0,9	<b>MR ICI 160 - 132 MB 4</b>	78,6
	<b>16,9</b>	488	1,25	<b>MR C2I 160 - 132 MB 4</b>	82,7
	<b>16,9</b>	490	1,8	<b>MR C2I 180 - 132 MB 4</b>	83,1
	<b>17,9</b>	461	2,36	<b>MR ICI 200 - 132 MB 4</b>	78,1
	<b>17,2</b>	480	2,65	<b>MR C2I 200 - 132 MB 4</b>	81,4
	<b>19,9</b>	414	1	<b>MR C2I 140 - 132 MB 4</b>	70,2
	<b>19,4</b>	427	1,5	<b>MR C2I 160 - 132 MB 4</b>	72,3
	<b>19,4</b>	425	2	<b>MR C2I 180 - 132 MB 4</b>	72
	<b>22,6</b>	365	1,12	<b>MR C2I 140 - 132 MB 4</b>	62
	<b>22,3</b>	371	1,4	<b>MR ICI 160 - 132 MB 4</b>	62,9
	<b>21,5</b>	385	1,6	<b>MR C2I 160 - 132 MB 4</b>	65,2
	<b>21,6</b>	382	1,5	<b>MR ICI 180 - 132 MB 4</b>	64,8
	<b>21,4</b>	386	2,24	<b>MR C2I 180 - 132 MB 4</b>	65,5
	<b>22,4</b>	369	3	<b>MR ICI 200 - 132 MB 4</b>	62,5
	<b>25,3</b>	327	1,32	<b>MR C2I 140 - 132 MB 4</b>	55,4
	<b>24,6</b>	336	1,9	<b>MR C2I 160 - 132 MB 4</b>	57
	<b>24,7</b>	335	2,5	<b>MR C2I 180 - 132 MB 4</b>	56,8
	<b>27,6</b>	299	0,8	<b>MR ICI 125 - 132 MB 4</b>	50,8
	<b>27,6</b>	299	0,95	<b>MR ICI 140 - 132 MB 4</b>	50,8
	<b>27,8</b>	298	1,4	<b>MR C2I 140 - 132 MB 4</b>	50,4
	<b>27,8</b>	297	1,8	<b>MR ICI 160 - 132 MB 4</b>	50,3
	<b>26,8</b>	308	2	<b>MR C2I 160 - 132 MB 4</b>	52,1
	<b>27</b>	306	2,36	<b>MR ICI 180 - 132 MB 4</b>	51,8
	<b>31,1</b>	266	1,6	<b>MR C2I 140 - 132 MB 4</b>	45,1
	<b>30,7</b>	269	2,36	<b>MR C2I 160 - 132 MB 4</b>	45,6
	<b>34,5</b>	240	1	<b>MR ICI 125 - 132 MB 4</b>	40,6
<b>34,5</b>	240	1,5	<b>MR ICI 140 - 132 MB 4</b>	40,6	
<b>36,2</b>	228	1,8	<b>MR C2I 140 - 132 MB 4</b>	38,7	

$P_1$ kW	$n_2$ min <sup>-1</sup>	$M_2$ daN m	$f_s$	Getriebe - Motor Gear reducer - Motor	$i$
1)				2)	
<b>9,2</b>	<b>33,1</b>	249	2,36	<b>MR ICI 160 - 132 MB 4</b>	42,3
	<b>35,4</b>	233	2,65	<b>MR C2I 160 - 132 MB 4</b>	39,5
	<b>37,3</b>	221	1,9	<b>MR C2I 140 - 132 MB 4</b>	37,5
	<b>37,4</b>	221	2,8	<b>MR C2I 160 - 132 MB 4</b>	37,5
	<b>43,1</b>	192	1,5	<b>MR ICI 125 - 132 MB 4</b>	32,5
	<b>44,8</b>	188	0,9	<b>MR CI 125 - 132 MB 4</b>	31,3
	<b>43,7</b>	189	1,9	<b>MR ICI 140 - 132 MB 4</b>	32
	<b>43,5</b>	190	1,9	<b>MR C2I 140 - 132 MB 4</b>	32,2
	<b>42</b>	197	3,15	<b>MR ICI 160 - 132 MB 4</b>	33,3
	<b>43,1</b>	192	3,35	<b>MR C2I 160 - 132 MB 4</b>	32,5
	<b>54,7</b>	151	1,8	<b>MR ICI 125 - 132 MB 4</b>	25,6
	<b>56</b>	151	1,6	<b>MR CI 125 - 132 MB 4</b>	25
	<b>53,6</b>	154	2,24	<b>MR ICI 140 - 132 MB 4</b>	26,1
	<b>72,6</b>	116	1	<b>MR CI 100 - 132 MB 4</b>	19,3
	<b>66,5</b>	124	2,24	<b>MR ICI 125 - 132 MB 4</b>	21
	<b>70</b>	120	1,9	<b>MR CI 125 - 132 MB 4</b>	20
	<b>70</b>	120	2,8	<b>MR CI 140 - 132 MB 4</b>	20
	<b>77,8</b>	108	3,15	<b>MR CI 140 - 132 MB 4</b>	18
	<b>89,2</b>	95	1,18	<b>MR CI 100 - 132 MB 4</b>	15,7
	<b>87,5</b>	96	2,5	<b>MR CI 125 - 132 MB 4</b>	16
	<b>113</b>	75	1,7	<b>MR CI 100 - 132 MB 4</b>	12,4
	<b>111</b>	76	3,55	<b>MR CI 125 - 132 MB 4</b>	12,6
	<b>136</b>	62	1,7	<b>MR CI 100 - 132 MB 4</b>	10,3
	<b>135</b>	62	3,75	<b>MR CI 125 - 132 MB 4</b>	10,4
<b>174</b>	48,6	1,7	<b>MR CI 100 - 132 MB 4</b>	8,06	
<b>175</b>	48,1	3,75	<b>MR CI 125 - 132 MB 4</b>	7,98	
<b>217</b>	38,9	1,7	<b>MR CI 100 - 132 MB 4</b>	6,46	
<b>222</b>	38	3,75	<b>MR CI 125 - 132 MB 4</b>	6,31	
<b>11</b>	<b>5,77</b>	1712	0,9	<b>MR C2I 225 - 160 L 6</b>	156
	<b>5,76</b>	1714	1,25	<b>MR C2I 250 - 160 L 6</b>	156
	<b>5,85</b>	1688	1,8	<b>MR C2I 280 - 160 L 6</b>	154
	<b>7,08</b>	1395	0,9	<b>MR C2I 200 - 160 L 6</b>	127
	<b>7,18</b>	1375	1,18	<b>MR C2I 225 - 160 L 6</b>	125
	<b>7,31</b>	1350	1,9	<b>MR C2I 250 - 160 L 6</b>	123
	<b>7,17</b>	1376	2,36	<b>MR C2I 280 - 160 L 6</b>	125
	<b>9,24</b>	1068	1	<b>MR C2I 200 - 132 MC 4</b>	151
	<b>9,24</b>	1068	1	<b>MR C2I 200 - 160 M 4</b>	151
	<b>8,85</b>	1116	1,12	<b>MR C2I 200 - 160 L 6</b>	102
	<b>8,97</b>	1101	1,4	<b>MR C2I 225 - 132 MC 4</b>	156
	<b>8,97</b>	1101	1,4	<b>MR C2I 225 - 160 M 4</b>	156
	<b>8,98</b>	1100	1,6	<b>MR C2I 225 - 160 L 6</b>	100
	<b>8,96</b>	1102	2	<b>MR C2I 250 - 160 M 4</b>	156
	<b>9,1</b>	1085	2,8	<b>MR C2I 280 - 160 M 4</b>	154
	<b>10</b>	987	0,85	<b>MR C2I 180 - 160 L 6</b>	90
	<b>10,8</b>	916	0,85	<b>MR C2I 180 - 132 MC 4</b>	130
	<b>10,8</b>	916	0,85	<b>MR C2I 180 - 160 M 4</b>	130
	<b>10,8</b>	912	0,95	<b>MR C2I 180 - 160 L 6</b>	83,1
	<b>12</b>	825	1,06	<b>MR ICI 200 - 132 MC 4</b>	117
	<b>11,5</b>	857	1,25	<b>MR ICI 200 - 160 L 6</b>	78,1
	<b>11</b>	897	1,4	<b>MR C2I 200 - 132 MC 4</b>	127
	<b>11</b>	897	1,4	<b>MR C2I 200 - 160 M 4</b>	127
	<b>11,2</b>	884	1,7	<b>MR C2I 225 - 132 MC 4</b>	125
	<b>11,2</b>	884	1,7	<b>MR C2I 225 - 160 M 4</b>	125
	<b>11,4</b>	868	2,8	<b>MR C2I 250 - 160 M 4</b>	123
	<b>13,5</b>	729	0,85	<b>MR C2I 160 - 132 MC 4</b>	103
	<b>13,5</b>	729	0,85	<b>MR C2I 160 - 160 M 4</b>	103
	<b>13,9</b>	711	0,85	<b>MR ICI 180 - 160 L 6</b>	64,8
	<b>13,5</b>	732	1,18	<b>MR C2I 180 - 132 MC 4</b>	104
	<b>13,5</b>	732	1,18	<b>MR C2I 180 - 160 M 4</b>	104
<b>15</b>	660	1,7	<b>MR ICI 200 - 132 MC 4</b>	93,5	
<b>14,3</b>	689	1,25	<b>MR ICI 200 - 160 M 4</b>	97,7	
<b>14,3</b>	690	1,6	<b>MR ICI 200 - 160 L 6</b>	62,9	
<b>13,8</b>	718	1,7	<b>MR C2I 200 - 132 MC 4</b>	102	
<b>13,8</b>	718	1,7	<b>MR C2I 200 - 160 M 4</b>	102	
<b>14</b>	707	2,5	<b>MR C2I 225 - 160 M 4</b>	100	
<b>15,5</b>	638	1	<b>MR C2I 160 - 132 MC 4</b>	90,4	
<b>15,5</b>	638	1	<b>MR C2I 160 - 160 M 4</b>	90,4	
<b>15,6</b>	635	1,32	<b>MR C2I 180 - 132 MC 4</b>	90	
<b>15,6</b>	635	1,32	<b>MR C2I 180 - 160 M 4</b>	90	
<b>15,9</b>	620	2,12	<b>MR C2I 200 - 160 M 4</b>	87,9	
<b>18,3</b>	540	1	<b>MR ICI 160 - 160 L 6</b>	49,2	

1) Leistungen bei Dauerbetrieb S1; bei Betriebsarten S2 ... S10 können sie **gesteigert** werden (s. Kap. 2b);  $M_2$  steigt und  $f_s$  fällt proportional.  
2) Zur vollständigen Bestellbezeichnung s. Kap. 3.

1) Powers valid for continuous duty S1; **increase** possible for S2 ... S10 (see ch. 2b); in which case  $M_2$  increases and  $f_s$  decreases proportionately.  
2) For complete designation when ordering see ch. 3.

14 - Herstellungsprogramm (Kegelstirnradgetriebemotoren)  
 14 - Manufacturing programme (right angle shafts)

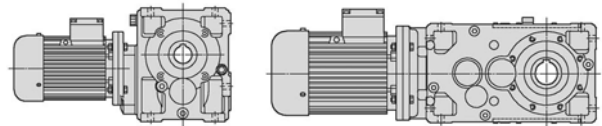

P <sub>1</sub> kW	n <sub>2</sub> min <sup>-1</sup>	M <sub>2</sub> daN m	f <sub>s</sub>	Getriebe - Motor Gear reducer - Motor	i
1)				2)	
<b>11</b>	<b>16,9</b>	583	1,06	MR C2I 160 - 132 MC 4	82,7
	<b>16,9</b>	583	1,06	MR C2I 160 - 160 M 4	82,7
	<b>16,9</b>	586	1,5	MR C2I 180 - 132 MC 4	83,1
	<b>16,9</b>	586	1,5	MR C2I 180 - 160 M 4	83,1
	<b>17,9</b>	551	2	MR ICI 200 - 132 MC 4	78,1
	<b>17,9</b>	551	2	MR ICI 200 - 160 M 4	78,1
	<b>17,2</b>	574	2,12	MR C2I 200 - 160 M 4	81,4
	<b>19,9</b>	495	0,85	MR C2I 140 - 132 MC 4	70,2
	<b>19,4</b>	510	1,25	MR C2I 160 - 132 MC 4	72,3
	<b>19,4</b>	510	1,25	MR C2I 160 - 160 M 4	72,3
	<b>19,4</b>	508	1,6	MR C2I 180 - 132 MC 4	72
	<b>19,4</b>	508	1,6	MR C2I 180 - 160 M 4	72
	<b>19,9</b>	496	2,65	MR C2I 200 - 160 M 4	70,3
	<b>22,6</b>	437	0,95	MR C2I 140 - 132 MC 4	62
	<b>22,3</b>	444	1,18	MR ICI 160 - 132 MC 4	62,9
	<b>22,3</b>	444	1,18	MR ICI 160 - 160 M 4	62,9
	<b>22,9</b>	432	1,25	MR ICI 160 - 160 L 6	39,4
	<b>21,5</b>	460	1,32	MR C2I 160 - 132 MC 4	65,2
	<b>21,5</b>	460	1,32	MR C2I 160 - 160 M 4	65,2
	<b>21,6</b>	457	1,32	MR ICI 180 - 132 MC 4	64,8
	<b>21,6</b>	457	1,32	MR ICI 180 - 160 M 4	64,8
	<b>22,2</b>	445	1,7	MR ICI 180 - 160 L 6	40,6
	<b>21,4</b>	462	1,9	MR C2I 180 - 132 MC 4	65,5
	<b>21,4</b>	462	1,9	MR C2I 180 - 160 M 4	65,5
	<b>22,3</b>	444	2,5	MR ICI 200 - 160 M 4	62,9
	<b>25,3</b>	390	1,06	MR C2I 140 - 132 MC 4	55,4
	<b>24,6</b>	402	1,6	MR C2I 160 - 132 MC 4	57
	<b>24,6</b>	402	1,6	MR C2I 160 - 160 M 4	57
	<b>24,7</b>	400	2	MR C2I 180 - 160 M 4	56,8
	<b>27,6</b>	358	0,8	MR ICI 140 - 132 MC 4	50,8
	<b>27,8</b>	356	1,18	MR C2I 140 - 132 MC 4	50,4
	<b>27,8</b>	355	1,5	MR ICI 160 - 132 MC 4	50,3
	<b>28,4</b>	347	1,5	MR ICI 160 - 160 M 4	49,2
	<b>26,8</b>	368	1,7	MR C2I 160 - 132 MC 4	52,1
	<b>26,8</b>	368	1,7	MR C2I 160 - 160 M 4	52,1
	<b>29,3</b>	345	1,06	MR CI 160 - 160 L 6	30,8
	<b>27</b>	366	2	MR ICI 180 - 132 MC 4	51,8
	<b>28,1</b>	351	2,12	MR ICI 180 - 160 L 6	32
	<b>26,7</b>	370	2,36	MR C2I 180 - 160 M 4	52,4
	<b>27,8</b>	355	3,15	MR ICI 200 - 160 M 4	50,3
	<b>31,1</b>	318	1,32	MR C2I 140 - 132 MC 4	45,1
	<b>30,7</b>	322	2	MR C2I 160 - 132 MC 4	45,6
	<b>30,7</b>	322	2	MR C2I 160 - 160 M 4	45,6
	<b>30,8</b>	320	2,8	MR C2I 180 - 160 M 4	45,4
	<b>34,5</b>	286	0,85	MR ICI 125 - 132 MC 4	40,6
	<b>36</b>	280	0,85	MR CI 125 - 160 L 6	25
	<b>34,5</b>	286	1,25	MR ICI 140 - 132 MC 4	40,6
	<b>36,2</b>	273	1,5	MR C2I 140 - 132 MC 4	38,7
	<b>33,1</b>	298	2	MR ICI 160 - 132 MC 4	42,3
	<b>35,5</b>	278	1,9	MR ICI 160 - 160 M 4	39,4
	<b>35,4</b>	279	2,24	MR C2I 160 - 160 M 4	39,5
	<b>36,6</b>	276	1,8	MR CI 160 - 160 L 6	24,6
	<b>34,3</b>	288	2,65	MR ICI 180 - 132 MC 4	40,9
	<b>34,5</b>	286	2,5	MR ICI 180 - 160 M 4	40,6
	<b>34,1</b>	289	3	MR C2I 180 - 160 M 4	41
	<b>37,3</b>	265	1,6	MR C2I 140 - 132 MC 4	37,5
	<b>37,4</b>	264	2,36	MR C2I 160 - 160 M 4	37,5
	<b>43,1</b>	229	1,25	MR ICI 125 - 132 MC 4	32,5
	<b>45</b>	224	1,06	MR CI 125 - 160 L 6	20
	<b>43,7</b>	226	1,6	MR ICI 140 - 132 MC 4	32
	<b>43,5</b>	227	1,6	MR C2I 140 - 132 MC 4	32,2
	<b>45</b>	224	1,6	MR CI 140 - 160 L 6	20
	<b>42,3</b>	233	2,5	MR ICI 160 - 160 M 4	33,1
	<b>43,1</b>	229	2,8	MR C2I 160 - 160 M 4	32,5
	<b>45,5</b>	222	1,5	MR CI 160 - 160 M 4	30,8
	<b>45,7</b>	221	2,36	MR CI 160 - 160 L 6	19,7
	<b>50</b>	202	1,7	MR CI 140 - 160 L 6	18
	<b>54,7</b>	181	1,5	MR ICI 125 - 132 MC 4	25,6
	<b>56</b>	180	1,32	MR CI 125 - 132 MC 4	25
	<b>56</b>	180	1,32	MR CI 125 - 160 M 4	25
	<b>53,6</b>	184	1,8	MR ICI 140 - 132 MC 4	26,1
	<b>57,1</b>	177	2	MR CI 140 - 160 L 6	15,8
	<b>53,7</b>	184	3,35	MR ICI 160 - 160 M 4	26,1
	<b>56,9</b>	177	2,65	MR CI 160 - 160 M 4	24,6

1) Leistungen bei Dauerbetrieb S1; bei Betriebsarten S2 ... S10 können sie gesteigert werden (s. Kap. 2b); M<sub>2</sub> steigt und f<sub>s</sub> fällt proportional.  
 2) Zur vollständigen Bestellbezeichnung s. Kap. 3.

P <sub>1</sub> kW	n <sub>2</sub> min <sup>-1</sup>	M <sub>2</sub> daN m	f <sub>s</sub>	Getriebe - Motor Gear reducer - Motor	i
1)				2)	
<b>11</b>	<b>63,4</b>	159	2,36	MR CI 140 - 160 L 6	14,2
	<b>72,6</b>	139	0,85	MR CI 100 - 132 MC 4	19,3
	<b>66,5</b>	148	1,8	MR ICI 125 - 132 MC 4	21
	<b>70</b>	144	1,6	MR CI 125 - 132 MC 4	20
	<b>70</b>	144	1,6	MR CI 125 - 160 M 4	20
	<b>70</b>	144	2,36	MR CI 140 - 132 MC 4	20
	<b>70</b>	144	2,36	MR CI 140 - 160 M 4	20
	<b>70,8</b>	139	3,75	MR ICI 160 - 160 M 4	19,8
	<b>77,8</b>	130	2,65	MR CI 140 - 160 M 4	18
	<b>89,2</b>	113	1	MR CI 100 - 132 MC 4	15,7
	<b>87,5</b>	115	2,12	MR CI 125 - 132 MC 4	16
	<b>87,5</b>	115	2,12	MR CI 125 - 160 M 4	16
	<b>113</b>	89	1,4	MR CI 100 - 132 MC 4	12,4
	<b>111</b>	91	3	MR CI 125 - 132 MC 4	12,6
	<b>111</b>	91	3	MR CI 125 - 160 M 4	12,6
	<b>136</b>	74	1,4	MR CI 100 - 132 MC 4	10,3
	<b>135</b>	75	3	MR CI 125 - 132 MC 4	10,4
	<b>135</b>	75	3	MR CI 125 - 160 M 4	10,4
	<b>174</b>	58	1,4	MR CI 100 - 132 MC 4	8,06
	<b>175</b>	57	3	MR CI 125 - 132 MC 4	7,98
	<b>175</b>	57	3	MR CI 125 - 160 M 4	7,98
	<b>217</b>	46,5	1,4	MR CI 100 - 132 MC 4	6,46
	<b>222</b>	45,4	3	MR CI 125 - 132 MC 4	6,31
	<b>222</b>	45,4	3	MR CI 125 - 160 M 4	6,31
<b>15</b>	<b>5,76</b>	2337	0,95	MR C2I 250 - 180 L 6	156
	<b>5,85</b>	2302	1,32	MR C2I 280 - 180 L 6	154
	<b>7,18</b>	1874	0,85	MR C2I 225 - 180 L 6	125
	<b>7,31</b>	1841	1,32	MR C2I 250 - 180 L 6	123
	<b>7,17</b>	1877	1,7	MR C2I 280 - 180 L 6	125
	<b>8,97</b>	1501	1	MR C2I 225 - 160 L 4	156
	<b>8,98</b>	1499	1,18	MR C2I 225 - 180 L 6	100
	<b>8,96</b>	1502	1,5	MR C2I 250 - 160 L 4	156
	<b>9,1</b>	1480	2	MR C2I 280 - 160 L 4	154
	<b>10,2</b>	1315	0,95	MR C2I 200 - 180 L 6	87,9
	<b>11</b>	1223	1	MR C2I 200 - 160 L 4	127
	<b>11,2</b>	1205	1,25	MR C2I 225 - 160 L 4	125
	<b>11,4</b>	1184	2,12	MR C2I 250 - 160 L 4	123
	<b>13,5</b>	999	0,9	MR C2I 180 - 160 L 4	104
	<b>15</b>	900	1,18	MR ICI 200 - 160 L 4	93,5
	<b>14,3</b>	939	0,9	MR ICI 200 - 160 L 4	97,7
	<b>14,3</b>	941	1,18	MR ICI 200 - 180 L 6	62,9
	<b>13,8</b>	979	1,25	MR C2I 200 - 160 L 4	102
	<b>14</b>	964	1,8	MR C2I 225 - 160 L 4	100
	<b>14,2</b>	947	2,65	MR C2I 250 - 160 L 4	98,5
	<b>15,6</b>	866	0,95	MR C2I 180 - 160 L 4	90
	<b>15,9</b>	846	1,5	MR C2I 200 - 160 L 4	87,9
	<b>15,5</b>	868	2,12	MR C2I 225 - 160 L 4	90,3
	<b>16,9</b>	799	1,12	MR C2I 180 - 160 L 4	83,1
	<b>17,9</b>	751	1,5	MR ICI 200 - 160 L 4	78,1
	<b>17,2</b>	783	1,6	MR C2I 200 - 160 L 4	81,4
	<b>17,5</b>	771	2,24	MR C2I 225 - 160 L 4	80,2
	<b>19,4</b>	695	0,9	MR C2I 160 - 160 L 4	72,3
	<b>19,4</b>	693	1,18	MR C2I 180 - 160 L 4	72
	<b>19,9</b>	676	1,9	MR C2I 200 - 160 L 4	70,3
	<b>19,4</b>	694	2,65	MR C2I 225 - 160 L 4	72,2
	<b>22,3</b>	605	0,9	MR ICI 160 - 160 L 4	62,9
	<b>21,5</b>	627	1	MR C2I 160 - 160 L 4	65,2
	<b>22,2</b>	607	1,25	MR ICI 180 - 180 L 6	40,6
	<b>21,4</b>	630	1,4	MR C2I 180 - 160 L 4	65,5
	<b>22,3</b>	605	1,8	MR ICI 200 - 160 L 4	62,9
	<b>21,8</b>	617	2	MR C2I 200 - 160 L 4	64,2
	<b>24,6</b>	548	1,12	MR C2I 160 - 160 L 4	57
	<b>24,7</b>	546	1,5	MR C2I 180 - 160 L 4	56,8
	<b>25,2</b>	533	2,36	MR C2I 200 - 160 L 4	55,5
	<b>27,8</b>	485	0,85	MR C2I 140 - 160 L 4	50,4
	<b>28,4</b>	474	1,12	MR ICI 160 - 160 L 4	49,2
	<b>26,8</b>	502	1,25	MR C2I 160 - 160 L 4	52,1
	<b>28,1</b>	479	1,6	MR ICI 180 - 180 L 6	32
	<b>26,7</b>	504	1,7	MR C2I 180 - 160 L 4	52,4
	<b>27,8</b>	484	2,24	MR ICI 200 - 160 L 4	50,3
	<b>26</b>	518	2,36	MR C2I 200 - 160 L 4	53,9

1) Powers valid for continuous duty S1; increase possible for S2 ... S10 (see ch. 2b); in which case M<sub>2</sub> increases and f<sub>s</sub> decreases proportionately.  
 2) For complete designation when ordering see ch. 3.

14 - Herstellungsprogramm (Kegelstirnradtriebemotoren)  
 14 - Manufacturing programme (right angle shafts)

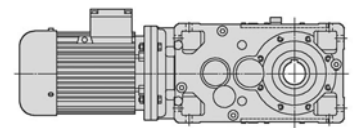
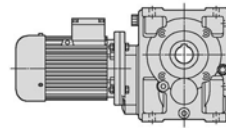

P <sub>1</sub> kW	n <sub>2</sub> min <sup>-1</sup>	M <sub>2</sub> daN m	f <sub>s</sub>	Getriebe - Motor Gear reducer - Motor	i
1)				2)	
<b>15</b>	<b>29,3</b>	470	1,5	MR CI 200 - 180 L 6	30,8
	<b>31,1</b>	434	1	MR C2I 140 - 160 L 4	45,1
	<b>30,7</b>	439	1,4	MR C2I 160 - 160 L 4	45,6
	<b>30,8</b>	437	2,12	MR C2I 180 - 160 L 4	45,4
	<b>34,5</b>	391	0,9	MR ICI 140 - 160 L 4	40,6
	<b>36,2</b>	372	1,12	MR C2I 140 - 160 L 4	38,7
	<b>35,5</b>	379	1,4	MR ICI 160 - 160 L 4	39,4
	<b>35,4</b>	380	1,7	MR C2I 160 - 160 L 4	39,5
	<b>36,6</b>	376	1,32	MR CI 160 - 180 L 6	24,6
	<b>34,5</b>	390	1,9	MR ICI 180 - 160 L 4	40,6
	<b>34,1</b>	394	2,12	MR C2I 180 - 160 L 4	41
	<b>33,1</b>	406	3	MR ICI 200 - 160 L 4	42,3
	<b>36,6</b>	376	2,65	MR CI 200 - 180 L 6	24,6
	<b>37,3</b>	361	1,18	MR C2I 140 - 160 L 4	37,5
	<b>37,4</b>	360	1,7	MR C2I 160 - 160 L 4	37,5
	<b>37,5</b>	359	2,5	MR C2I 180 - 160 L 4	37,3
	<b>45</b>	306	0,8	MR CI 125 - 180 L 6	20
	<b>43,7</b>	308	1,12	MR ICI 140 - 160 L 4	32
	<b>43,5</b>	310	1,18	MR C2I 140 - 160 L 4	32,2
	<b>45</b>	306	1,12	MR CI 140 - 180 L 6	20
	<b>42,3</b>	318	1,9	MR ICI 160 - 160 L 4	33,1
	<b>43,1</b>	312	2	MR C2I 160 - 160 L 4	32,5
	<b>45,5</b>	302	1,12	MR CI 160 - 160 L 4	30,8
	<b>45,7</b>	301	1,7	MR CI 160 - 180 L 6	19,7
	<b>43,8</b>	308	2,36	MR ICI 180 - 160 L 4	32
	<b>41,6</b>	324	2,5	MR C2I 180 - 160 L 4	33,7
	<b>44,4</b>	310	2,24	MR CI 180 - 180 L 6	20,3
	<b>45,7</b>	301	3,55	MR CI 200 - 180 L 6	19,7
	<b>50</b>	275	1,25	MR CI 140 - 180 L 6	18
	<b>56</b>	246	0,95	MR CI 125 - 160 L 4	25
	<b>53,6</b>	251	1,32	MR ICI 140 - 160 L 4	26,1
	<b>57,1</b>	241	1,4	MR CI 140 - 180 L 6	15,8
	<b>53,7</b>	251	2,36	MR ICI 160 - 160 L 4	26,1
	<b>56,9</b>	242	1,9	MR CI 160 - 160 L 4	24,6
	<b>63,4</b>	217	1,7	MR CI 140 - 180 L 6	14,2
	<b>70</b>	196	1,18	MR CI 125 - 160 L 4	20
	<b>70</b>	196	1,7	MR CI 140 - 160 L 4	20
	<b>70,8</b>	190	2,8	MR ICI 160 - 160 L 4	19,8
	<b>71,1</b>	193	2,65	MR CI 160 - 160 L 4	19,7
	<b>77,8</b>	177	1,9	MR CI 140 - 160 L 4	18
	<b>77,8</b>	177	3	MR CI 160 - 160 L 4	18
	<b>87,5</b>	157	1,5	MR CI 125 - 160 L 4	16
	<b>88,8</b>	155	2,12	MR CI 140 - 160 L 4	15,8
	<b>84,7</b>	162	3	MR CI 160 - 160 L 4	16,5
<b>98,6</b>	139	2,5	MR CI 140 - 160 L 4	14,2	
<b>111</b>	124	2,12	MR CI 125 - 160 L 4	12,6	
<b>135</b>	102	2,24	MR CI 125 - 160 L 4	10,4	
<b>175</b>	78	2,24	MR CI 125 - 160 L 4	7,98	
<b>222</b>	62	2,24	MR CI 125 - 160 L 4	6,31	
<b>18,5</b>	<b>5,85</b>	2839	1,06	MR C2I 280 - 200 LR 6	154
	<b>5,76</b>	2883	1,32	MR C2I 320 - 200 LR 6	156
	<b>5,76</b>	2883	1,6	MR C2I 321 - 200 LR 6	156
	<b>5,59</b>	2969	2	MR C2I 360 - 200 LR 6	161
	<b>7,31</b>	2271	1,12	MR C2I 250 - 200 LR 6	123
	<b>7,17</b>	2315	1,4	MR C2I 280 - 200 LR 6	125
	<b>6,97</b>	2381	1,8	MR C2I 320 - 200 LR 6	129
	<b>6,97</b>	2381	2,24	MR C2I 321 - 200 LR 6	129
	<b>8,98</b>	1849	0,95	MR C2I 225 - 200 LR 6	100
	<b>8,96</b>	1853	1,18	MR C2I 250 - 180 M 4	156
	<b>9,14</b>	1817	1,4	MR C2I 250 - 200 LR 6	98,5
	<b>9,1</b>	1825	1,6	MR C2I 280 - 180 M 4	154
	<b>8,97</b>	1852	1,9	MR C2I 280 - 200 LR 6	100
	<b>9,97</b>	1665	1,06	MR C2I 225 - 200 LR 6	90,3
	<b>10</b>	1655	2,12	MR C2I 280 - 200 LR 6	89,7
	<b>11</b>	1509	0,85	MR C2I 200 - 180 M 4	127
	<b>11,2</b>	1486	1,06	MR C2I 225 - 180 M 4	125
	<b>11,2</b>	1479	1,18	MR C2I 225 - 200 LR 6	80,2
	<b>11,4</b>	1460	1,7	MR C2I 250 - 180 M 4	123
	<b>11,2</b>	1488	2,12	MR C2I 280 - 180 M 4	125
	<b>14,3</b>	1161	0,95	MR ICI 200 - 200 LR 6	62,9

P <sub>1</sub> kW	n <sub>2</sub> min <sup>-1</sup>	M <sub>2</sub> daN m	f <sub>s</sub>	Getriebe - Motor Gear reducer - Motor	i
1)				2)	
<b>18,5</b>	<b>13,8</b>	1207	1,06	MR C2I 200 - 180 M 4	102
	<b>14</b>	1189	1,5	MR C2I 225 - 180 M 4	100
	<b>14,2</b>	1168	2,12	MR C2I 250 - 180 M 4	98,5
	<b>15,9</b>	1043	1,25	MR C2I 200 - 180 M 4	87,9
	<b>15,5</b>	1071	1,7	MR C2I 225 - 180 M 4	90,3
	<b>15,7</b>	1056	2,5	MR C2I 250 - 180 M 4	89
	<b>16,9</b>	985	0,9	MR C2I 180 - 180 M 4	83,1
	<b>17,8</b>	933	0,9	MR ICI 200 - 180 M 4	78,6
	<b>18,3</b>	908	1,18	MR ICI 200 - 200 LR 6	49,2
	<b>17,2</b>	966	1,32	MR C2I 200 - 180 M 4	81,4
	<b>17,5</b>	951	1,8	MR C2I 225 - 180 M 4	80,2
	<b>17,8</b>	934	2,65	MR C2I 250 - 180 M 4	78,8
	<b>19,4</b>	854	0,95	MR C2I 180 - 180 M 4	72
	<b>19,9</b>	834	1,5	MR C2I 200 - 180 M 4	70,3
	<b>19,4</b>	857	2,12	MR C2I 225 - 180 M 4	72,2
	<b>21,4</b>	777	1,12	MR C2I 180 - 180 M 4	65,5
	<b>22,3</b>	746	1,5	MR ICI 200 - 180 M 4	62,9
	<b>21,8</b>	761	1,6	MR C2I 200 - 180 M 4	64,2
	<b>22,1</b>	750	2,36	MR C2I 225 - 180 M 4	63,2
	<b>24,6</b>	676	0,95	MR C2I 160 - 180 M 4	57
	<b>24,7</b>	673	1,18	MR C2I 180 - 180 M 4	56,8
	<b>25,2</b>	658	1,9	MR C2I 200 - 180 M 4	55,5
	<b>24,6</b>	675	2,65	MR C2I 225 - 180 M 4	56,9
	<b>28,4</b>	584	0,9	MR ICI 160 - 180 M 4	49,2
	<b>26,8</b>	619	1	MR C2I 160 - 180 M 4	52,1
	<b>26,7</b>	622	1,4	MR C2I 180 - 180 M 4	52,4
	<b>27,8</b>	597	1,8	MR ICI 200 - 180 M 4	50,3
	<b>26</b>	639	2	MR C2I 200 - 180 M 4	53,9
	<b>29,3</b>	580	1,18	MR CI 200 - 200 LR 6	30,8
	<b>26,4</b>	630	2,8	MR C2I 225 - 180 M 4	53,1
	<b>30,7</b>	541	1,18	MR C2I 160 - 180 M 4	45,6
	<b>30,8</b>	539	1,7	MR C2I 180 - 180 M 4	45,4
	<b>30,1</b>	552	2,36	MR C2I 200 - 180 M 4	46,6
	<b>35,5</b>	467	1,12	MR ICI 160 - 180 M 4	39,4
	<b>35,4</b>	469	1,32	MR C2I 160 - 180 M 4	39,5
	<b>36,6</b>	464	1,06	MR CI 160 - 200 LR 6	24,6
	<b>34,5</b>	481	1,5	MR ICI 180 - 180 M 4	40,6
	<b>34,1</b>	486	1,7	MR C2I 180 - 180 M 4	41
	<b>33,1</b>	501	2,36	MR ICI 200 - 180 M 4	42,3
	<b>32,9</b>	505	2,5	MR C2I 200 - 180 M 4	42,6
	<b>36,6</b>	464	2,12	MR CI 200 - 200 LR 6	24,6
	<b>37,4</b>	444	1,4	MR C2I 160 - 180 M 4	37,5
	<b>37,5</b>	443	2	MR C2I 180 - 180 M 4	37,3
	<b>39,7</b>	419	3	MR C2I 200 - 180 M 4	35,3
	<b>42,3</b>	392	1,5	MR ICI 160 - 180 M 4	33,1
	<b>43,1</b>	385	1,6	MR C2I 160 - 180 M 4	32,5
	<b>45,5</b>	373	0,9	MR CI 160 - 180 M 4	30,8
	<b>45,7</b>	371	1,4	MR CI 160 - 200 LR 6	19,7
	<b>43,8</b>	379	2	MR ICI 180 - 180 M 4	32
	<b>41,6</b>	400	2	MR C2I 180 - 180 M 4	33,7
	<b>44,4</b>	382	1,8	MR CI 180 - 200 LR 6	20,3
	<b>42</b>	395	3,15	MR ICI 200 - 180 M 4	33,3
	<b>43,4</b>	383	3,35	MR C2I 200 - 180 M 4	32,3
	<b>45,5</b>	373	1,8	MR CI 200 - 180 M 4	30,8
<b>45,7</b>	371	3	MR CI 200 - 200 LR 6	19,7	
<b>48,2</b>	352	2	MR CI 180 - 200 LR 6	18,7	
<b>56</b>	303	0,8	MR CI 125 - 180 M 4	25	
<b>53,7</b>	309	2	MR ICI 160 - 180 M 4	26,1	
<b>56,9</b>	298	1,6	MR CI 160 - 180 M 4	24,6	
<b>56,3</b>	301	2,36	MR CI 180 - 200 LR 6	16	
<b>56,9</b>	298	3,15	MR CI 200 - 180 M 4	24,6	
<b>70</b>	242	0,95	MR CI 125 - 180 M 4	20	
<b>70</b>	242	1,4	MR CI 140 - 180 M 4	20	
<b>70,8</b>	234	2,24	MR ICI 160 - 180 M 4	19,8	
<b>71,1</b>	239	2,12	MR CI 160 - 180 M 4	19,7	
<b>69</b>	246	2,8	MR CI 180 - 180 M 4	20,3	
<b>77,8</b>	218	1,6	MR CI 140 - 180 M 4	18	
<b>77,8</b>	218	2,5	MR CI 160 - 180 M 4	18	
<b>87,5</b>	194	1,25	MR CI 125 - 180 M 4	16	
<b>88,8</b>	191	1,8	MR CI 140 - 180 M 4	15,8	
<b>84,7</b>	200	2,5	MR CI 160 - 180 M 4	16,5	
<b>98,6</b>	172	2	MR CI 140 - 180 M 4	14,2	

1) Leistungen bei Dauerbetrieb S1; bei Betriebsarten S2 ... S10 können sie **gesteigert** werden (s. Kap. 2b); M<sub>2</sub> steigt und f<sub>s</sub> fällt proportional.  
 2) Zur vollständigen Bestellbezeichnung s. Kap. 3.

1) Powers valid for continuous duty S1; **increase** possible for S2 ... S10 (see ch. 2b); in which case M<sub>2</sub> increases and f<sub>s</sub> decreases proportionately.  
 2) For complete designation when ordering see ch. 3.

14 - Herstellungsprogramm (Kegelstirnradgetriebemotoren)  
14 - Manufacturing programme (right angle shafts)

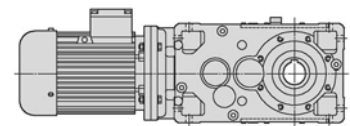
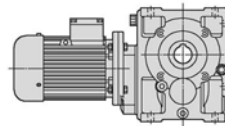

$P_1$ kW	$n_2$ min <sup>-1</sup>	$M_2$ daN m	$f_s$	Getriebe - Motor Gear reducer - Motor	$i$
1)				2)	
<b>18,5</b>	<b>98,6</b>	172	3,15	MR CI 160 - 180 M 4	14,2
	<b>111</b>	153	1,7	MR CI 125 - 180 M 4	12,6
	<b>109</b>	156	2	MR CI 140 - 180 M 4	12,9
	<b>107</b>	158	3,55	MR CI 160 - 180 M 4	13
	<b>122</b>	139	2	MR CI 140 - 180 M 4	11,5
	<b>123</b>	138	3,55	MR CI 160 - 180 M 4	11,4
	<b>135</b>	126	1,8	MR CI 125 - 180 M 4	10,4
	<b>142</b>	119	2	MR CI 140 - 180 M 4	9,86
	<b>142</b>	120	3,55	MR CI 160 - 180 M 4	9,88
	<b>175</b>	97	1,8	MR CI 125 - 180 M 4	7,98
	<b>182</b>	93	3,55	MR CI 160 - 180 M 4	7,71
	<b>222</b>	76	1,8	MR CI 125 - 180 M 4	6,31
	<b>227</b>	75	3,55	MR CI 160 - 180 M 4	6,16
	<b>22</b>	<b>5,85</b>	3376	0,9	MR C2I 280 - 200 L 6
<b>5,76</b>		3428	1,12	MR C2I 320 - 200 L 6	156
<b>5,76</b>		3428	1,32	MR C2I 321 - 200 L 6	156
<b>5,59</b>		3531	1,7	MR C2I 360 - 200 L 6	161
<b>7,31</b>		2701	0,95	MR C2I 250 - 200 L 6	123
<b>7,17</b>		2753	1,18	MR C2I 280 - 200 L 6	125
<b>6,97</b>		2832	1,5	MR C2I 320 - 200 L 6	129
<b>6,97</b>		2832	1,9	MR C2I 321 - 200 L 6	129
<b>8,96</b>		2204	1	MR C2I 250 - 180 L 4	156
<b>9,14</b>		2161	1,18	MR C2I 250 - 200 L 6	98,5
<b>9,1</b>		2170	1,4	MR C2I 280 - 180 L 4	154
<b>8,97</b>		2202	1,6	MR C2I 280 - 200 L 6	100
<b>9,97</b>		1981	0,9	MR C2I 225 - 200 L 6	90,3
<b>10,1</b>		1953	1,32	MR C2I 250 - 200 L 6	89
<b>10</b>		1968	1,8	MR C2I 280 - 200 L 6	89,7
<b>11,2</b>		1767	0,85	MR C2I 225 - 180 L 4	125
<b>11,2</b>		1759	1	MR C2I 225 - 200 L 6	80,2
<b>11,4</b>		1736	1,4	MR C2I 250 - 180 L 4	123
<b>11,2</b>		1770	1,7	MR C2I 280 - 180 L 4	125
<b>13,8</b>		1435	0,85	MR C2I 200 - 180 L 4	102
<b>14</b>		1414	1,25	MR C2I 225 - 180 L 4	100
<b>14,2</b>		1389	1,8	MR C2I 250 - 180 L 4	98,5
<b>14</b>		1416	2,5	MR C2I 280 - 180 L 4	100
<b>15,9</b>		1240	1,06	MR C2I 200 - 180 L 4	87,9
<b>15,5</b>		1273	1,4	MR C2I 225 - 180 L 4	90,3
<b>15,7</b>		1255	2	MR C2I 250 - 180 L 4	89
<b>18,3</b>		1080	1	MR ICI 200 - 200 L 6	49,2
<b>17,2</b>		1148	1,06	MR C2I 200 - 180 L 4	81,4
<b>17,5</b>		1131	1,5	MR C2I 225 - 180 L 4	80,2
<b>17,8</b>		1111	2,24	MR C2I 250 - 180 L 4	78,8
<b>19,9</b>		992	1,32	MR C2I 200 - 180 L 4	70,3
<b>19,4</b>		1019	1,8	MR C2I 225 - 180 L 4	72,2
<b>19,7</b>		1004	2,5	MR C2I 250 - 180 L 4	71,2
<b>21,4</b>		924	0,95	MR C2I 180 - 180 L 4	65,5
<b>22,3</b>		887	1,25	MR ICI 200 - 180 L 4	62,9
<b>21,8</b>		905	1,4	MR C2I 200 - 180 L 4	64,2
<b>22,1</b>		892	2	MR C2I 225 - 180 L 4	63,2
<b>24,7</b>		801	1	MR C2I 180 - 180 L 4	56,8
<b>25,2</b>		782	1,6	MR C2I 200 - 180 L 4	55,5
<b>24,6</b>		803	2,24	MR C2I 225 - 180 L 4	56,9
<b>26,8</b>		736	0,85	MR C2I 160 - 180 L 4	52,1
<b>26,7</b>		739	1,18	MR C2I 180 - 180 L 4	52,4
<b>27,8</b>		710	1,5	MR ICI 200 - 180 L 4	50,3
<b>26</b>		760	1,6	MR C2I 200 - 180 L 4	53,9
<b>29,3</b>		690	1	MR CI 200 - 200 L 6	30,8
<b>26,4</b>		749	2,36	MR C2I 225 - 180 L 4	53,1
<b>30,7</b>		643	1	MR C2I 160 - 180 L 4	45,6
<b>30,8</b>		641	1,4	MR C2I 180 - 180 L 4	45,4
<b>30,1</b>		657	1,9	MR C2I 200 - 180 L 4	46,6
<b>29,3</b>		674	2,65	MR C2I 225 - 180 L 4	47,8
<b>35,5</b>		556	0,95	MR ICI 160 - 180 L 4	39,4
<b>35,4</b>		558	1,12	MR C2I 160 - 180 L 4	39,5
<b>36,6</b>		552	0,9	MR CI 160 - 200 L 6	24,6
<b>34,5</b>		572	1,25	MR ICI 180 - 180 L 4	40,6
<b>34,1</b>		578	1,5	MR C2I 180 - 180 L 4	41
<b>33,1</b>		596	2	MR ICI 200 - 180 L 4	42,3
<b>32,9</b>		601	2,12	MR C2I 200 - 180 L 4	42,6
<b>36,6</b>		552	1,8	MR CI 200 - 200 L 6	24,6

$P_1$ kW	$n_2$ min <sup>-1</sup>	$M_2$ daN m	$f_s$	Getriebe - Motor Gear reducer - Motor	$i$
1)				2)	
<b>22</b>	<b>33,8</b>	584	3,15	MR C2I 225 - 180 L 4	41,4
	<b>37,4</b>	529	1,18	MR C2I 160 - 180 L 4	37,5
	<b>37,5</b>	526	1,7	MR C2I 180 - 180 L 4	37,3
	<b>39,7</b>	498	2,65	MR C2I 200 - 180 L 4	35,3
	<b>42,3</b>	466	1,25	MR ICI 160 - 180 L 4	33,1
	<b>43,1</b>	458	1,4	MR C2I 160 - 180 L 4	32,5
	<b>45,7</b>	441	1,18	MR CI 160 - 200 L 6	19,7
	<b>43,8</b>	451	1,6	MR ICI 180 - 180 L 4	32
	<b>41,6</b>	475	1,7	MR C2I 180 - 180 L 4	33,7
	<b>44,4</b>	455	1,6	MR CI 180 - 200 L 6	20,3
	<b>42</b>	470	2,65	MR ICI 200 - 180 L 4	33,3
	<b>43,4</b>	455	2,8	MR C2I 200 - 180 L 4	32,3
	<b>45,5</b>	443	1,5	MR CI 200 - 180 L 4	30,8
	<b>45,7</b>	441	2,5	MR CI 200 - 200 L 6	19,7
	<b>50</b>	403	1,4	MR CI 160 - 200 L 6	18
	<b>48,2</b>	418	1,7	MR CI 180 - 200 L 6	18,7
	<b>53,7</b>	368	1,7	MR ICI 160 - 180 L 4	26,1
	<b>56,9</b>	355	1,32	MR CI 160 - 180 L 4	24,6
	<b>53,4</b>	370	1,9	MR ICI 180 - 180 L 4	26,2
	<b>56,3</b>	358	2	MR CI 180 - 200 L 6	16
	<b>53,2</b>	371	3	MR ICI 200 - 180 L 4	26,3
	<b>56,9</b>	355	2,65	MR CI 200 - 180 L 4	24,6
	<b>61,1</b>	330	2,36	MR CI 180 - 200 L 6	14,7
	<b>70</b>	288	0,8	MR CI 125 - 180 L 4	20
	<b>70</b>	288	1,18	MR CI 140 - 180 L 4	20
	<b>70,8</b>	279	1,9	MR ICI 160 - 180 L 4	19,8
	<b>71,1</b>	284	1,8	MR CI 160 - 180 L 4	19,7
	<b>69</b>	292	2,36	MR CI 180 - 180 L 4	20,3
	<b>77,8</b>	259	1,32	MR CI 140 - 180 L 4	18
	<b>77,8</b>	259	2,12	MR CI 160 - 180 L 4	18
	<b>87,5</b>	231	1,06	MR CI 125 - 180 L 4	16
	<b>88,8</b>	227	1,5	MR CI 140 - 180 L 4	15,8
	<b>84,7</b>	238	2,12	MR CI 160 - 180 L 4	16,5
	<b>98,6</b>	204	1,7	MR CI 140 - 180 L 4	14,2
	<b>98,6</b>	204	2,65	MR CI 160 - 180 L 4	14,2
	<b>111</b>	182	1,5	MR CI 125 - 180 L 4	12,6
	<b>109</b>	185	1,7	MR CI 140 - 180 L 4	12,9
	<b>107</b>	188	3	MR CI 160 - 180 L 4	13
	<b>122</b>	166	1,7	MR CI 140 - 180 L 4	11,5
	<b>123</b>	164	3	MR CI 160 - 180 L 4	11,4
	<b>135</b>	149	1,5	MR CI 125 - 180 L 4	10,4
	<b>142</b>	142	1,7	MR CI 140 - 180 L 4	9,86
<b>142</b>	142	3	MR CI 160 - 180 L 4	9,88	
<b>175</b>	115	1,5	MR CI 125 - 180 L 4	7,98	
<b>182</b>	111	3	MR CI 160 - 180 L 4	7,71	
<b>222</b>	91	1,5	MR CI 125 - 180 L 4	6,31	
<b>227</b>	89	3	MR CI 160 - 180 L 4	6,16	
<b>30</b>	<b>5,76</b>	4674	0,95	MR C2I 321 - 225 M 6	156
	<b>5,59</b>	4815	1,25	MR C2I 360 - 225 M 6	161
	<b>7,17</b>	3754	0,85	MR C2I 280 - 225 M 6	125
	<b>6,97</b>	3861	1,12	MR C2I 320 - 225 M 6	129
	<b>6,97</b>	3861	1,4	MR C2I 321 - 225 M 6	129
	<b>7,09</b>	3798	1,7	MR C2I 360 - 225 M 6	127
	<b>9,14</b>	2946	0,85	MR C2I 250 - 225 M 6	98,5
	<b>9,1</b>	2959	1	MR C2I 280 - 200 L 4	154
	<b>8,97</b>	3003	1,12	MR C2I 280 - 225 M 6	100
	<b>8,96</b>	3005	1,25	MR C2I 320 - 200 L 4	156
	<b>8,96</b>	3005	1,5	MR C2I 321 - 200 L 4	156
	<b>8,7</b>	3096	1,9	MR C2I 360 - 200 L 4	161
	<b>10,1</b>	2663	0,95	MR C2I 250 - 225 M 6	89
	<b>10,1</b>	2683	1,32	MR C2I 280 - 225 M 6	89,7
	<b>11,4</b>	2368	1,06	MR C2I 250 - 200 L 4	123
	<b>11,2</b>	2413	1,25	MR C2I 280 - 200 L 4	125
	<b>10,8</b>	2482	1,8	MR C2I 320 - 200 L 4	129
	<b>10,8</b>	2482	2,12	MR C2I 321 - 200 L 4	129
	<b>14</b>	1928	0,9	MR C2I 225 - 200 L 4	100
	<b>14,2</b>	1894	1,32	MR C2I 250 - 200 L 4	98,5
	<b>14</b>	1930	1,8	MR C2I 280 - 200 L 4	100
	<b>13,6</b>	1986	2,24	MR C2I 320 - 200 L 4	103
	<b>15,5</b>	1736	1,06	MR C2I 225 - 200 L 4	90,3

1) Leistungen bei Dauerbetrieb S1; bei Betriebsarten S2 ... S10 können sie gesteigert werden (s. Kap. 2b);  $M_2$  steigt und  $f_s$  fällt proportional.  
2) Zur vollständigen Bestellbezeichnung s. Kap. 3.

1) Powers valid for continuous duty S1; increase possible for S2 ... S10 (see ch. 2b); in which case  $M_2$  increases and  $f_s$  decreases proportionately.  
2) For complete designation when ordering see ch. 3.



14 - Herstellungsprogramm (Kegelstirnradgetriebemotoren)  
14 - Manufacturing programme (right angle shafts)

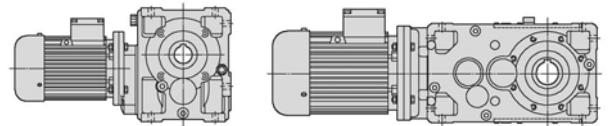

P <sub>1</sub> kW	n <sub>2</sub> min <sup>-1</sup>	M <sub>2</sub> daN m	f <sub>s</sub>	Getriebe - Motor Gear reducer - Motor	i	
1)				2)		
<b>30</b>	<b>15,7</b>	1712	1,5	<b>MR C2I 250 - 200 L</b>	<b>4</b>	<b>89</b>
	<b>15,6</b>	1725	2	<b>MR C2I 280 - 200 L</b>	<b>4</b>	<b>89,7</b>
	<b>17,5</b>	1542	1,12	<b>MR C2I 225 - 200 L</b>	<b>4</b>	<b>80,2</b>
	<b>17,8</b>	1515	1,6	<b>MR C2I 250 - 200 L</b>	<b>4</b>	<b>78,8</b>
	<b>17,4</b>	1544	2,24	<b>MR C2I 280 - 200 L</b>	<b>4</b>	<b>80,3</b>
	<b>19,9</b>	1353	0,95	<b>MR C2I 200 - 200 L</b>	<b>4</b>	<b>70,3</b>
	<b>19,4</b>	1389	1,32	<b>MR C2I 225 - 200 L</b>	<b>4</b>	<b>72,2</b>
	<b>19,7</b>	1370	1,9	<b>MR C2I 250 - 200 L</b>	<b>4</b>	<b>71,2</b>
	<b>19,5</b>	1380	2,65	<b>MR C2I 280 - 200 L</b>	<b>4</b>	<b>71,7</b>
	<b>22,3</b>	1210	0,9	<b>MR ICI 200 - 200 L</b>	<b>4</b>	<b>62,9</b>
	<b>21,8</b>	1235	1	<b>MR C2I 200 - 200 L</b>	<b>4</b>	<b>64,2</b>
	<b>22,1</b>	1216	1,4	<b>MR C2I 225 - 200 L</b>	<b>4</b>	<b>63,2</b>
	<b>22,5</b>	1195	2,12	<b>MR C2I 250 - 200 L</b>	<b>4</b>	<b>62,1</b>
	<b>25,2</b>	1067	1,18	<b>MR C2I 200 - 200 L</b>	<b>4</b>	<b>55,5</b>
	<b>24,6</b>	1095	1,6	<b>MR C2I 225 - 200 L</b>	<b>4</b>	<b>56,9</b>
	<b>24,9</b>	1080	2,36	<b>MR C2I 250 - 200 L</b>	<b>4</b>	<b>56,1</b>
	<b>26,7</b>	1008	0,85	<b>MR C2I 180 - 200 L</b>	<b>4</b>	<b>52,4</b>
	<b>28,4</b>	947	1,18	<b>MR ICI 200 - 200 L</b>	<b>4</b>	<b>49,2</b>
	<b>26</b>	1036	1,18	<b>MR C2I 200 - 200 L</b>	<b>4</b>	<b>53,9</b>
	<b>26,4</b>	1021	1,7	<b>MR C2I 225 - 200 L</b>	<b>4</b>	<b>53,1</b>
	<b>26,8</b>	1003	2,5	<b>MR C2I 250 - 200 L</b>	<b>4</b>	<b>52,1</b>
	<b>28,4</b>	970	1,5	<b>MR CI 250 - 225 M</b>	<b>6</b>	<b>31,7</b>
	<b>30,8</b>	874	1,06	<b>MR C2I 180 - 200 L</b>	<b>4</b>	<b>45,4</b>
	<b>30,1</b>	896	1,4	<b>MR C2I 200 - 200 L</b>	<b>4</b>	<b>46,6</b>
	<b>29,3</b>	919	2	<b>MR C2I 225 - 200 L</b>	<b>4</b>	<b>47,8</b>
	<b>29,7</b>	907	2,8	<b>MR C2I 250 - 200 L</b>	<b>4</b>	<b>47,1</b>
	<b>32,2</b>	853	1,5	<b>MR CI 250 - 225 M</b>	<b>6</b>	<b>27,9</b>
	<b>34,5</b>	780	0,95	<b>MR ICI 180 - 200 L</b>	<b>4</b>	<b>40,6</b>
	<b>34,1</b>	789	1,06	<b>MR C2I 180 - 200 L</b>	<b>4</b>	<b>41</b>
	<b>35,5</b>	758	1,4	<b>MR ICI 200 - 200 L</b>	<b>4</b>	<b>39,4</b>
	<b>32,9</b>	819	1,6	<b>MR C2I 200 - 200 L</b>	<b>4</b>	<b>42,6</b>
	<b>36,6</b>	752	1,32	<b>MR CI 200 - 225 M</b>	<b>6</b>	<b>24,6</b>
	<b>33,8</b>	797	2,24	<b>MR C2I 225 - 200 L</b>	<b>4</b>	<b>41,4</b>
	<b>35,5</b>	776	2,65	<b>MR CI 250 - 225 M</b>	<b>6</b>	<b>25,4</b>
	<b>37,5</b>	718	1,25	<b>MR C2I 180 - 200 L</b>	<b>4</b>	<b>37,3</b>
	<b>39,7</b>	679	1,9	<b>MR C2I 200 - 200 L</b>	<b>4</b>	<b>35,3</b>
	<b>38,6</b>	697	2,5	<b>MR C2I 225 - 200 L</b>	<b>4</b>	<b>36,2</b>
	<b>45,7</b>	602	0,85	<b>MR CI 160 - 225 M</b>	<b>6</b>	<b>19,7</b>
	<b>43,8</b>	615	1,18	<b>MR ICI 180 - 200 L</b>	<b>4</b>	<b>32</b>
	<b>41,6</b>	648	1,25	<b>MR C2I 180 - 200 L</b>	<b>4</b>	<b>33,7</b>
	<b>44,4</b>	620	1,12	<b>MR CI 180 - 225 M</b>	<b>6</b>	<b>20,3</b>
	<b>42,3</b>	636	1,8	<b>MR ICI 200 - 200 L</b>	<b>4</b>	<b>33,1</b>
	<b>43,4</b>	621	2,12	<b>MR C2I 200 - 200 L</b>	<b>4</b>	<b>32,3</b>
	<b>45,5</b>	604	1,12	<b>MR CI 200 - 200 L</b>	<b>4</b>	<b>30,8</b>
	<b>45,7</b>	602	1,8	<b>MR CI 200 - 225 M</b>	<b>6</b>	<b>19,7</b>
	<b>44,6</b>	604	2,5	<b>MR C2I 225 - 200 L</b>	<b>4</b>	<b>31,4</b>
<b>44,4</b>	620	2,24	<b>MR CI 225 - 225 M</b>	<b>6</b>	<b>20,3</b>	
<b>50</b>	550	1	<b>MR CI 160 - 225 M</b>	<b>6</b>	<b>18</b>	
<b>48,2</b>	570	1,25	<b>MR CI 180 - 225 M</b>	<b>6</b>	<b>18,7</b>	
<b>56,9</b>	484	0,95	<b>MR CI 160 - 200 L</b>	<b>4</b>	<b>24,6</b>	
<b>53,4</b>	504	1,4	<b>MR ICI 180 - 200 L</b>	<b>4</b>	<b>26,2</b>	
<b>56,3</b>	489	1,5	<b>MR CI 180 - 225 M</b>	<b>6</b>	<b>16</b>	
<b>53,7</b>	502	2,5	<b>MR ICI 200 - 200 L</b>	<b>4</b>	<b>26,1</b>	
<b>56,9</b>	484	1,9	<b>MR CI 200 - 200 L</b>	<b>4</b>	<b>24,6</b>	
<b>61,1</b>	450	1,7	<b>MR CI 180 - 225 M</b>	<b>6</b>	<b>14,7</b>	
<b>70</b>	393	0,85	<b>MR CI 140 - 200 L</b>	<b>4</b>	<b>20</b>	
<b>71,1</b>	387	1,32	<b>MR CI 160 - 200 L</b>	<b>4</b>	<b>19,7</b>	
<b>69</b>	399	1,7	<b>MR CI 180 - 200 L</b>	<b>4</b>	<b>20,3</b>	
<b>67,9</b>	396	2,65	<b>MR ICI 200 - 200 L</b>	<b>4</b>	<b>20,6</b>	
<b>71,1</b>	387	2,8	<b>MR CI 200 - 200 L</b>	<b>4</b>	<b>19,7</b>	
<b>77,8</b>	354	0,95	<b>MR CI 140 - 200 L</b>	<b>4</b>	<b>18</b>	
<b>77,8</b>	354	1,5	<b>MR CI 160 - 200 L</b>	<b>4</b>	<b>18</b>	
<b>75</b>	367	1,9	<b>MR CI 180 - 200 L</b>	<b>4</b>	<b>18,7</b>	
<b>77,8</b>	354	3	<b>MR CI 200 - 200 L</b>	<b>4</b>	<b>18</b>	
<b>88,8</b>	310	1,06	<b>MR CI 140 - 200 L</b>	<b>4</b>	<b>15,8</b>	
<b>84,7</b>	325	1,5	<b>MR CI 160 - 200 L</b>	<b>4</b>	<b>16,5</b>	
<b>87,5</b>	314	2,24	<b>MR CI 180 - 200 L</b>	<b>4</b>	<b>16</b>	
<b>98,6</b>	279	1,25	<b>MR CI 140 - 200 L</b>	<b>4</b>	<b>14,2</b>	
<b>98,6</b>	279	2	<b>MR CI 160 - 200 L</b>	<b>4</b>	<b>14,2</b>	
<b>95,1</b>	289	2,5	<b>MR CI 180 - 200 L</b>	<b>4</b>	<b>14,7</b>	
<b>109</b>	253	1,25	<b>MR CI 140 - 200 L</b>	<b>4</b>	<b>12,9</b>	
<b>107</b>	256	2,24	<b>MR CI 160 - 200 L</b>	<b>4</b>	<b>13</b>	

P <sub>1</sub> kW	n <sub>2</sub> min <sup>-1</sup>	M <sub>2</sub> daN m	f <sub>s</sub>	Getriebe - Motor Gear reducer - Motor	i		
1)				2)			
<b>30</b>	<b>122</b>	226	1,25	<b>MR CI 140 - 200 L</b>	<b>4</b>	<b>11,5</b>	
	<b>123</b>	224	2,24	<b>MR CI 160 - 200 L</b>	<b>4</b>	<b>11,4</b>	
	<b>142</b>	194	1,25	<b>MR CI 140 - 200 L</b>	<b>4</b>	<b>9,86</b>	
	<b>142</b>	194	2,24	<b>MR CI 160 - 200 L</b>	<b>4</b>	<b>9,88</b>	
	<b>182</b>	151	2,24	<b>MR CI 160 - 200 L</b>	<b>4</b>	<b>7,71</b>	
	<b>227</b>	121	2,24	<b>MR CI 160 - 200 L</b>	<b>4</b>	<b>6,16</b>	
	<b>37</b>	<b>5,59</b>	5939	1	<b>MR C2I 360 - 250 M</b>	<b>6</b>	<b>161</b>
		<b>6,97</b>	4762	0,9	<b>MR C2I 320 - 250 M</b>	<b>6</b>	<b>129</b>
		<b>6,97</b>	4762	1,12	<b>MR C2I 321 - 250 M</b>	<b>6</b>	<b>129</b>
		<b>7,09</b>	4684	1,4	<b>MR C2I 360 - 250 M</b>	<b>6</b>	<b>127</b>
		<b>8,97</b>	3704	0,95	<b>MR C2I 280 - 250 M</b>	<b>6</b>	<b>100</b>
		<b>8,96</b>	3706	1	<b>MR C2I 320 - 225 S</b>	<b>4</b>	<b>156</b>
		<b>8,96</b>	3706	1,18	<b>MR C2I 321 - 225 S</b>	<b>4</b>	<b>156</b>
<b>8,72</b>		3810	1,12	<b>MR C2I 320 - 250 M</b>	<b>6</b>	<b>103</b>	
<b>8,72</b>		3810	1,4	<b>MR C2I 321 - 250 M</b>	<b>6</b>	<b>103</b>	
<b>8,7</b>		3818	1,6	<b>MR C2I 360 - 225 S</b>	<b>4</b>	<b>161</b>	
<b>8,86</b>		3747	1,8	<b>MR C2I 360 - 250 M</b>	<b>6</b>	<b>102</b>	
<b>10</b>		3309	1,06	<b>MR C2I 280 - 250 M</b>	<b>6</b>	<b>89,7</b>	
<b>11,4</b>		2920	0,85	<b>MR C2I 250 - 225 S</b>	<b>4</b>	<b>123</b>	
<b>11,2</b>		2976	1,06	<b>MR C2I 280 - 225 S</b>	<b>4</b>	<b>125</b>	
<b>11,2</b>		2963	1,18	<b>MR C2I 280 - 250 M</b>	<b>6</b>	<b>80,3</b>	
<b>10,8</b>		3061	1,4	<b>MR C2I 320 - 225 S</b>	<b>4</b>	<b>129</b>	
<b>10,8</b>		3061	1,7	<b>MR C2I 321 - 225 S</b>	<b>4</b>	<b>129</b>	
<b>11</b>		3011	2	<b>MR C2I 360 - 225 S</b>	<b>4</b>	<b>127</b>	
<b>14,2</b>		2336	1,06	<b>MR C2I 250 - 225 S</b>	<b>4</b>	<b>98,5</b>	
<b>14</b>		2381	1,4	<b>MR C2I 280 - 225 S</b>	<b>4</b>	<b>100</b>	
<b>13,6</b>		2449	1,8	<b>MR C2I 320 - 225 S</b>	<b>4</b>	<b>103</b>	
<b>13,6</b>		2449	2,12	<b>MR C2I 321 - 225 S</b>	<b>4</b>	<b>103</b>	
<b>15,5</b>		2141	0,85	<b>MR C2I 225 - 225 S</b>	<b>4</b>	<b>90,3</b>	
<b>15,7</b>		2111	1,18	<b>MR C2I 250 - 225 S</b>	<b>4</b>	<b>89</b>	
<b>15,6</b>		2127	1,7	<b>MR C2I 280 - 225 S</b>	<b>4</b>	<b>89,7</b>	
<b>15,8</b>		2108	2,12	<b>MR C2I 320 - 225 S</b>	<b>4</b>	<b>88,8</b>	
<b>17,5</b>		1902	0,9	<b>MR C2I 225 - 225 S</b>	<b>4</b>	<b>80,2</b>	
<b>17,8</b>		1869	1,32	<b>MR C2I 250 - 225 S</b>	<b>4</b>	<b>78,8</b>	
<b>17,4</b>		1905	1,8	<b>MR C2I 280 - 225 S</b>	<b>4</b>	<b>80,3</b>	
<b>17</b>		1959	2,24	<b>MR C2I 320 - 225 S</b>	<b>4</b>	<b>82,6</b>	
<b>19,4</b>		1713	1,06	<b>MR C2I 225 - 225 S</b>	<b>4</b>	<b>72,2</b>	
<b>19,7</b>		1689	1,5	<b>MR C2I 250 - 225 S</b>	<b>4</b>	<b>71,2</b>	
<b>19,5</b>		1702	2,12	<b>MR C2I 280 - 225 S</b>	<b>4</b>	<b>71,7</b>	
<b>22,1</b>		1500	1,18	<b>MR C2I 225 - 225 S</b>	<b>4</b>	<b>63,2</b>	
<b>22,5</b>		1473	1,7	<b>MR C2I 250 - 225 S</b>	<b>4</b>	<b>62,1</b>	
<b>22,1</b>		1502	2,24	<b>MR C2I 280 - 225 S</b>	<b>4</b>	<b>63,3</b>	
<b>25,2</b>		1316	0,95	<b>MR C2I 200 - 225 S</b>	<b>4</b>	<b>55,5</b>	
<b>24,6</b>		1351	1,32	<b>MR C2I 225 - 225 S</b>	<b>4</b>	<b>56,9</b>	
<b>24,9</b>		1332	1,9	<b>MR C2I 250 - 225 S</b>	<b>4</b>	<b>56,1</b>	
<b>24,8</b>		1342	2,65	<b>MR C2I 280 - 225 S</b>	<b>4</b>	<b>56,6</b>	
<b>28,4</b>		1168	0,95	<b>MR ICI 200 - 225 S</b>	<b>4</b>	<b>49,2</b>	
<b>26</b>		1278	1	<b>MR C2I 200 - 225 S</b>	<b>4</b>	<b>53,9</b>	
<b>26,4</b>	1259	1,4	<b>MR C2I 225 - 225 S</b>	<b>4</b>	<b>53,1</b>		
<b>26,8</b>	1237	2	<b>MR C2I 250 - 225 S</b>	<b>4</b>	<b>52,1</b>		
<b>28,4</b>	1196	1,18	<b>MR CI 250 - 250 M</b>	<b>6</b>	<b>31,7</b>		
<b>26,3</b>	1261	2,8	<b>MR C2I 280 - 225 S</b>	<b>4</b>	<b>53,1</b>		
<b>30,1</b>	1105	1,18	<b>MR C2I 200 - 225 S</b>	<b>4</b>	<b>46,6</b>		
<b>29,3</b>	1134	1,6	<b>MR C2I 225 - 225 S</b>	<b>4</b>	<b>47,8</b>		
<b>29,7</b>	1118	2,24	<b>MR C2I 250 - 225 S</b>	<b>4</b>	<b>47,1</b>		
<b>32,2</b>	1052	1,18	<b>MR CI 250 - 250 M</b>	<b>6</b>	<b>27,9</b>		
<b>35,5</b>	934	1,18	<b>MR ICI 200 - 225 S</b>	<b>4</b>	<b>39,4</b>		
<b>32,9</b>	1010	1,25	<b>MR C2I 200 - 225 S</b>	<b>4</b>	<b>42,6</b>		
<b>36,6</b>	928	1,06	<b>MR CI 200 - 250 M</b>	<b>6</b>	<b>24,6</b>		
<b>33,8</b>	982	1,8	<b>MR C2I 225 - 225 S</b>	<b>4</b>	<b>41,4</b>		
<b>32,7</b>	1016	2,5	<b>MR C2I 250 - 225 S</b>	<b>4</b>	<b>42,8</b>		
<b>35,5</b>	957	2,12	<b>MR CI 250 - 250 M</b>	<b>6</b>	<b>25,4</b>		
<b>39,7</b>	837	1,5	<b>MR C2I 200 - 225 S</b>	<b>4</b>	<b>35,3</b>		
<b>38,6</b>	860	2	<b>MR C2I 225 - 225 S</b>	<b>4</b>	<b>36,2</b>		
<b>37,6</b>	884	3	<b>MR C2I 250 - 225 S</b>	<b>4</b>	<b>37,2</b>		
<b>40,3</b>	842	2,12	<b>MR CI 250 - 250 M</b>	<b>6</b>	<b>22,3</b>		
<b>42,3</b>	785	1,5	<b>MR ICI 200 - 225 S</b>	<b>4</b>	<b>33,1</b>		
<b>43,4</b>	766	1,7	<b>MR C2I 200 - 225 S</b>	<b>4</b>	<b>32,3</b>		
<b>45,5</b>	746	0,9	<b>MR CI 200 - 225 S</b>	<b>4</b>	<b>30,8</b>		
<b>45,7</b>	742	1,5	<b>MR CI 200 - 250 M</b>	<b>6</b>	<b>19,7</b>		
<b>44,6</b>	745	2	<b>MR C2I 225 - 225 S</b>	<b>4</b>	<b>31,4</b>		

1) Leistungen bei Dauerbetrieb S1; bei Betriebsarten S2 ... S10 können sie gesteigert werden (s. Kap. 2b); M<sub>2</sub> steigt und f<sub>s</sub> fällt proportional.  
2) Zur vollständigen Bestellbezeichnung s. Kap. 3.

1) Powers valid for continuous duty S1; increase possible for S2 ... S10 (see ch. 2b); in which case M<sub>2</sub> increases and f<sub>s</sub> decreases proportionately.  
2) For complete designation when ordering see ch. 3.

14 - Herstellungsprogramm (Kegelstirnradgetriebemotoren)  
 14 - Manufacturing programme (right angle shafts)

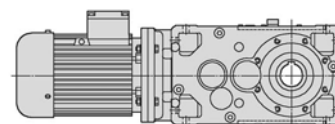
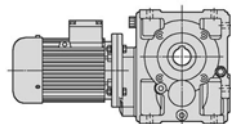

$P_1$ kW 1)	$n_2$ min <sup>-1</sup>	$M_2$ daN m	$f_s$	Getriebe - Motor Gear reducer - Motor 2)	$i$
<b>37</b>	<b>44,4</b>	765	1,8	<b>MR CI 225 - 250 M</b> <b>6</b>	20,3
	<b>41,4</b>	803	3,15	<b>MR C2I 250 - 225 S</b> <b>4</b>	33,9
	<b>44,1</b>	769	1,8	<b>MR CI 250 - 225 S</b> <b>4</b>	31,7
	<b>44,3</b>	765	2,8	<b>MR CI 250 - 250 M</b> <b>6</b>	20,3
	<b>48,2</b>	704	1,8	<b>MR CI 225 - 250 M</b> <b>6</b>	18,7
	<b>50,1</b>	676	1,8	<b>MR CI 250 - 225 S</b> <b>4</b>	27,9
	<b>53,7</b>	619	2	<b>MR ICI 200 - 225 S</b> <b>4</b>	26,1
	<b>56,9</b>	596	1,6	<b>MR CI 200 - 225 S</b> <b>4</b>	24,6
	<b>56,3</b>	603	2,36	<b>MR CI 225 - 250 M</b> <b>6</b>	16
	<b>55,2</b>	615	3,15	<b>MR CI 250 - 225 S</b> <b>4</b>	25,4
	<b>71,1</b>	477	1,06	<b>MR CI 160 - 225 S</b> <b>4</b>	19,7
	<b>69</b>	492	1,4	<b>MR CI 180 - 225 S</b> <b>4</b>	20,3
	<b>67,9</b>	489	2,24	<b>MR ICI 200 - 225 S</b> <b>4</b>	20,6
	<b>71,1</b>	477	2,24	<b>MR CI 200 - 225 S</b> <b>4</b>	19,7
	<b>69</b>	492	2,8	<b>MR CI 225 - 225 S</b> <b>4</b>	20,3
	<b>77,8</b>	436	1,25	<b>MR CI 160 - 225 S</b> <b>4</b>	18
	<b>75</b>	452	1,6	<b>MR CI 180 - 225 S</b> <b>4</b>	18,7
	<b>77,8</b>	436	2,5	<b>MR CI 200 - 225 S</b> <b>4</b>	18
	<b>84,7</b>	401	1,25	<b>MR CI 160 - 225 S</b> <b>4</b>	16,5
	<b>87,5</b>	388	1,8	<b>MR CI 180 - 225 S</b> <b>4</b>	16
	<b>84,7</b>	401	2,5	<b>MR CI 200 - 225 S</b> <b>4</b>	16,5
	<b>98,6</b>	344	1,6	<b>MR CI 160 - 225 S</b> <b>4</b>	14,2
	<b>95,1</b>	357	2	<b>MR CI 180 - 225 S</b> <b>4</b>	14,7
	<b>98,6</b>	344	3,35	<b>MR CI 200 - 225 S</b> <b>4</b>	14,2
	<b>107</b>	316	1,8	<b>MR CI 160 - 225 S</b> <b>4</b>	13
	<b>107</b>	317	2	<b>MR CI 180 - 225 S</b> <b>4</b>	13,1
	<b>107</b>	316	3,55	<b>MR CI 200 - 225 S</b> <b>4</b>	13
	<b>123</b>	276	1,8	<b>MR CI 160 - 225 S</b> <b>4</b>	11,4
	<b>123</b>	275	2	<b>MR CI 180 - 225 S</b> <b>4</b>	11,4
	<b>124</b>	273	3,55	<b>MR CI 200 - 225 S</b> <b>4</b>	11,3
	<b>142</b>	239	1,8	<b>MR CI 160 - 225 S</b> <b>4</b>	9,88
	<b>137</b>	248	2	<b>MR CI 180 - 225 S</b> <b>4</b>	10,3
	<b>136</b>	250	3,55	<b>MR CI 200 - 225 S</b> <b>4</b>	10,3
	<b>182</b>	187	1,8	<b>MR CI 160 - 225 S</b> <b>4</b>	7,71
	<b>174</b>	195	3,55	<b>MR CI 200 - 225 S</b> <b>4</b>	8,06
	<b>227</b>	149	1,8	<b>MR CI 160 - 225 S</b> <b>4</b>	6,16
	<b>217</b>	156	3,55	<b>MR CI 200 - 225 S</b> <b>4</b>	6,46
<b>45</b>	<b>5,59</b>	7223	0,85	<b>MR C2I 360 - 280 S</b> <b>6</b>	161
	<b>6,97</b>	5792	0,9	<b>MR C2I 321 - 280 S</b> <b>6</b>	129
	<b>7,09</b>	5697	1,12	<b>MR C2I 360 - 280 S</b> <b>6</b>	127
	<b>8,96</b>	4507	0,85	<b>MR C2I 320 - 225 M</b> <b>4</b>	156
	<b>8,96</b>	4507	1	<b>MR C2I 321 - 225 M</b> <b>4</b>	156
	<b>8,72</b>	4634	0,95	<b>MR C2I 320 - 280 S</b> <b>6</b>	103
	<b>8,72</b>	4634	1,12	<b>MR C2I 321 - 280 S</b> <b>6</b>	103
	<b>8,7</b>	4643	1,32	<b>MR C2I 360 - 225 M</b> <b>4</b>	161
	<b>8,86</b>	4558	1,5	<b>MR C2I 360 - 280 S</b> <b>6</b>	102
	<b>10</b>	4025	0,9	<b>MR C2I 280 - 280 S</b> <b>6</b>	89,7
	<b>10,1</b>	3988	1,12	<b>MR C2I 320 - 280 S</b> <b>6</b>	88,8
	<b>11,2</b>	3620	0,85	<b>MR C2I 280 - 225 M</b> <b>4</b>	125
	<b>11,2</b>	3604	0,95	<b>MR C2I 280 - 280 S</b> <b>6</b>	80,3
	<b>10,8</b>	3723	1,18	<b>MR C2I 320 - 225 M</b> <b>4</b>	129
	<b>10,8</b>	3723	1,4	<b>MR C2I 321 - 225 M</b> <b>4</b>	129
	<b>11</b>	3662	1,7	<b>MR C2I 360 - 225 M</b> <b>4</b>	127
	<b>14,2</b>	2841	0,9	<b>MR C2I 250 - 225 M</b> <b>4</b>	98,5
	<b>14</b>	2896	1,18	<b>MR C2I 280 - 225 M</b> <b>4</b>	100
	<b>13,6</b>	2979	1,5	<b>MR C2I 320 - 225 M</b> <b>4</b>	103
	<b>13,6</b>	2979	1,8	<b>MR C2I 321 - 225 M</b> <b>4</b>	103
	<b>13,8</b>	2930	2,36	<b>MR C2I 360 - 225 M</b> <b>4</b>	102
	<b>15,7</b>	2568	1	<b>MR C2I 250 - 225 M</b> <b>4</b>	89
	<b>15,6</b>	2587	1,4	<b>MR C2I 280 - 225 M</b> <b>4</b>	89,7
	<b>15,8</b>	2564	1,8	<b>MR C2I 320 - 225 M</b> <b>4</b>	88,8
	<b>15,8</b>	2564	2,24	<b>MR C2I 321 - 225 M</b> <b>4</b>	88,8
	<b>17,8</b>	2273	1,12	<b>MR C2I 250 - 225 M</b> <b>4</b>	78,8
	<b>17,4</b>	2317	1,5	<b>MR C2I 280 - 225 M</b> <b>4</b>	80,3
	<b>17</b>	2383	1,8	<b>MR C2I 320 - 225 M</b> <b>4</b>	82,6
	<b>17</b>	2383	2,24	<b>MR C2I 321 - 225 M</b> <b>4</b>	82,6
	<b>19,4</b>	2083	0,85	<b>MR C2I 225 - 225 M</b> <b>4</b>	72,2
	<b>19,7</b>	2054	1,25	<b>MR C2I 250 - 225 M</b> <b>4</b>	71,2
	<b>19,5</b>	2070	1,7	<b>MR C2I 280 - 225 M</b> <b>4</b>	71,7
	<b>19,7</b>	2051	2,24	<b>MR C2I 320 - 225 M</b> <b>4</b>	71,1

$P_1$ kW 1)	$n_2$ min <sup>-1</sup>	$M_2$ daN m	$f_s$	Getriebe - Motor Gear reducer - Motor 2)	$i$
<b>45</b>	<b>22,1</b>	1824	0,95	<b>MR C2I 225 - 225 M</b> <b>4</b>	63,2
	<b>22,5</b>	1792	1,4	<b>MR C2I 250 - 225 M</b> <b>4</b>	62,1
	<b>22,1</b>	1827	1,9	<b>MR C2I 280 - 225 M</b> <b>4</b>	63,3
	<b>21,5</b>	1879	2,36	<b>MR C2I 320 - 225 M</b> <b>4</b>	65,1
	<b>24,6</b>	1643	1,12	<b>MR C2I 225 - 225 M</b> <b>4</b>	56,9
	<b>24,9</b>	1620	1,6	<b>MR C2I 250 - 225 M</b> <b>4</b>	56,1
	<b>24,8</b>	1632	2,12	<b>MR C2I 280 - 225 M</b> <b>4</b>	56,6
	<b>26,4</b>	1531	1,12	<b>MR C2I 225 - 225 M</b> <b>4</b>	53,1
	<b>26,8</b>	1505	1,7	<b>MR C2I 250 - 225 M</b> <b>4</b>	52,1
	<b>28,4</b>	1455	1	<b>MR CI 250 - 280 S</b> <b>6</b>	31,7
	<b>26,3</b>	1534	2,24	<b>MR C2I 280 - 225 M</b> <b>4</b>	53,1
	<b>30,1</b>	1343	0,95	<b>MR C2I 200 - 225 M</b> <b>4</b>	46,6
	<b>29,3</b>	1379	1,32	<b>MR C2I 225 - 225 M</b> <b>4</b>	47,8
	<b>29,7</b>	1360	1,9	<b>MR C2I 250 - 225 M</b> <b>4</b>	47,1
	<b>32,2</b>	1280	1	<b>MR CI 250 - 280 S</b> <b>6</b>	27,9
	<b>29,5</b>	1370	2,65	<b>MR C2I 280 - 225 M</b> <b>4</b>	47,5
	<b>35,5</b>	1136	0,95	<b>MR ICI 200 - 225 M</b> <b>4</b>	39,4
	<b>32,9</b>	1229	1,06	<b>MR C2I 200 - 225 M</b> <b>4</b>	42,6
	<b>36,6</b>	1128	0,85	<b>MR CI 200 - 280 S</b> <b>6</b>	24,6
	<b>33,8</b>	1195	1,5	<b>MR C2I 225 - 225 M</b> <b>4</b>	41,4
	<b>32,7</b>	1236	2,12	<b>MR C2I 250 - 225 M</b> <b>4</b>	42,8
	<b>35,5</b>	1164	1,7	<b>MR CI 250 - 280 S</b> <b>6</b>	25,4
	<b>33,7</b>	1199	3	<b>MR C2I 280 - 225 M</b> <b>4</b>	41,6
	<b>39,7</b>	1018	1,25	<b>MR C2I 200 - 225 M</b> <b>4</b>	35,3
	<b>38,6</b>	1046	1,7	<b>MR C2I 225 - 225 M</b> <b>4</b>	36,2
	<b>37,6</b>	1075	2,36	<b>MR C2I 250 - 225 M</b> <b>4</b>	37,2
	<b>40,3</b>	1024	1,7	<b>MR CI 250 - 280 S</b> <b>6</b>	22,3
	<b>42,3</b>	954	1,25	<b>MR ICI 200 - 225 M</b> <b>4</b>	33,1
	<b>43,4</b>	931	1,4	<b>MR C2I 200 - 225 M</b> <b>4</b>	32,3
	<b>45,7</b>	903	1,18	<b>MR CI 200 - 280 S</b> <b>6</b>	19,7
	<b>44,6</b>	906	1,7	<b>MR C2I 225 - 225 M</b> <b>4</b>	31,4
	<b>44,4</b>	930	1,5	<b>MR CI 225 - 280 S</b> <b>6</b>	20,3
	<b>41,4</b>	977	2,65	<b>MR C2I 250 - 225 M</b> <b>4</b>	33,9
	<b>44,1</b>	935	1,5	<b>MR CI 250 - 225 M</b> <b>4</b>	31,7
	<b>44,3</b>	931	2,36	<b>MR CI 250 - 280 S</b> <b>6</b>	20,3
	<b>50</b>	825	1,32	<b>MR CI 200 - 280 S</b> <b>6</b>	18
	<b>48,2</b>	856	1,5	<b>MR CI 225 - 280 S</b> <b>6</b>	18,7
	<b>50,1</b>	823	1,5	<b>MR CI 250 - 225 M</b> <b>4</b>	27,9
	<b>50,4</b>	819	2,65	<b>MR CI 250 - 280 S</b> <b>6</b>	17,9
	<b>53,7</b>	752	1,6	<b>MR ICI 200 - 225 M</b> <b>4</b>	26,1
	<b>56,9</b>	725	1,32	<b>MR CI 200 - 225 M</b> <b>4</b>	24,6
	<b>56,3</b>	733	2	<b>MR CI 225 - 280 S</b> <b>6</b>	16
	<b>55,2</b>	748	2,65	<b>MR CI 250 - 225 M</b> <b>4</b>	25,4
	<b>61,1</b>	675	2,24	<b>MR CI 225 - 280 S</b> <b>6</b>	14,7
	<b>62,7</b>	658	2,65	<b>MR CI 250 - 225 M</b> <b>4</b>	22,3
	<b>71,1</b>	580	0,9	<b>MR CI 160 - 225 M</b> <b>4</b>	19,7
	<b>69</b>	598	1,12	<b>MR CI 180 - 225 M</b> <b>4</b>	20,3
	<b>67,9</b>	595	1,8	<b>MR ICI 200 - 225 M</b> <b>4</b>	20,6
	<b>71,1</b>	580	1,8	<b>MR CI 200 - 225 M</b> <b>4</b>	19,7
	<b>69</b>	598	2,24	<b>MR CI 225 - 225 M</b> <b>4</b>	20,3
	<b>77,8</b>	530	1	<b>MR CI 160 - 225 M</b> <b>4</b>	18
	<b>75</b>	550	1,32	<b>MR CI 180 - 225 M</b> <b>4</b>	18,7
	<b>77,8</b>	530	2	<b>MR CI 200 - 225 M</b> <b>4</b>	18
	<b>75</b>	550	2,24	<b>MR CI 225 - 225 M</b> <b>4</b>	18,7
	<b>84,7</b>	487	1	<b>MR CI 160 - 225 M</b> <b>4</b>	16,5
	<b>87,5</b>	471	1,5	<b>MR CI 180 - 225 M</b> <b>4</b>	16
	<b>84,7</b>	487	2	<b>MR CI 200 - 225 M</b> <b>4</b>	16,5
	<b>87,5</b>	471	3	<b>MR CI 225 - 225 M</b> <b>4</b>	16
	<b>98,6</b>	418	1,32	<b>MR CI 160 - 225 M</b> <b>4</b>	14,2
	<b>95,1</b>	434	1,7	<b>MR CI 180 - 225 M</b> <b>4</b>	14,7
	<b>98,6</b>	418	2,65	<b>MR CI 200 - 225 M</b> <b>4</b>	14,2
	<b>107</b>	384	1,5	<b>MR CI 160 - 225 M</b> <b>4</b>	13
	<b>107</b>	386	1,7	<b>MR CI 180 - 225 M</b> <b>4</b>	13,1
	<b>107</b>	384	3	<b>MR CI 200 - 225 M</b> <b>4</b>	13
	<b>123</b>	336	1,5	<b>MR CI 160 - 225 M</b> <b>4</b>	11,4
	<b>123</b>	335	1,7	<b>MR CI 180 - 225 M</b> <b>4</b>	11,4
	<b>124</b>	332	3	<b>MR CI 200 - 225 M</b> <b>4</b>	11,3
	<b>142</b>	291	1,5	<b>MR CI 160 - 225 M</b> <b>4</b>	9,88
	<b>137</b>	302	1,7	<b>MR CI 180 - 225 M</b> <b>4</b>	10,3
	<b>136</b>	304	3	<b>MR CI 200 - 225 M</b> <b>4</b>	10,3
	<b>182</b>	227	1,5	<b>MR CI 160 - 225 M</b> <b>4</b>	7,71
	<b>174</b>	238	3	<b>MR CI 200 - 225 M</b> <b>4</b>	8,06

1) Leistungen bei Dauerbetrieb S1; bei Betriebsarten S2 ... S10 können sie **gesteigert** werden (s. Kap. 2b);  $M_2$  steigt und  $f_s$  fällt proportional.  
 2) Zur vollständigen Bestellbezeichnung s. Kap. 3.

1) Powers valid for continuous duty S1; **increase** possible for S2 ... S10 (see ch. 2b); in which case  $M_2$  increases and  $f_s$  decreases proportionately.  
 2) For complete designation when ordering see ch. 3.

# 14 - Herstellungsprogramm (Kegelstirnradtriebmotoren)

## 14 - Manufacturing programme (right angle shafts)

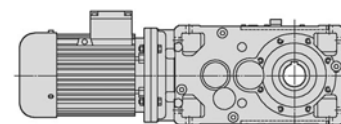
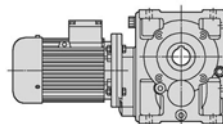

P <sub>1</sub> kW 1)	n <sub>2</sub> min <sup>-1</sup>	M <sub>2</sub> daN m	f <sub>s</sub>	Getriebe - Motor Gear reducer - Motor 2)	i
<b>45</b>	<b>227</b> <b>217</b>	181 190	1,5 3	<b>MR CI 160 - 225 M 4</b> <b>MR CI 200 - 225 M 4</b>	6,16 6,46
<b>55</b>	<b>8,7</b> <b>10,8</b> <b>10,8</b> <b>11</b>	5675 4551 4551 4476	1,06 0,95 1,18 1,4	<b>MR C2I 360 - 250 M 4</b> <b>MR C2I 320 - 250 M 4</b> <b>MR C2I 321 - 250 M 4</b> <b>MR C2I 360 - 250 M 4</b>	161 129 129 127
	<b>14</b> <b>13,6</b> <b>13,6</b> <b>13,8</b>	3539 3641 3641 3581	0,95 1,18 1,5 1,9	<b>MR C2I 280 - 250 M 4</b> <b>MR C2I 320 - 250 M 4</b> <b>MR C2I 321 - 250 M 4</b> <b>MR C2I 360 - 250 M 4</b>	100 103 103 102
	<b>15,6</b> <b>15,8</b> <b>15,8</b> <b>15,3</b>	3162 3133 3133 3223	1,12 1,4 1,8 2,24	<b>MR C2I 280 - 250 M 4</b> <b>MR C2I 320 - 250 M 4</b> <b>MR C2I 321 - 250 M 4</b> <b>MR C2I 360 - 250 M 4</b>	89,7 88,8 88,8 91,4
	<b>17,8</b> <b>17,4</b> <b>17</b> <b>17</b> <b>17,2</b>	2778 2831 2912 2912 2865	0,9 1,18 1,5 1,8 2,36	<b>MR C2I 250 - 250 M 4</b> <b>MR C2I 280 - 250 M 4</b> <b>MR C2I 320 - 250 M 4</b> <b>MR C2I 321 - 250 M 4</b> <b>MR C2I 360 - 250 M 4</b>	78,8 80,3 82,6 82,6 81,2
	<b>19,7</b> <b>19,5</b> <b>19,7</b> <b>19,7</b>	2511 2530 2507 2507	1 1,4 1,8 2,24	<b>MR C2I 250 - 250 M 4</b> <b>MR C2I 280 - 250 M 4</b> <b>MR C2I 320 - 250 M 4</b> <b>MR C2I 321 - 250 M 4</b>	71,2 71,7 71,1 71,1
	<b>22,5</b> <b>22,1</b> <b>21,5</b> <b>21,5</b>	2190 2232 2296 2296	1,12 1,5 1,9 2,36	<b>MR C2I 250 - 250 M 4</b> <b>MR C2I 280 - 250 M 4</b> <b>MR C2I 320 - 250 M 4</b> <b>MR C2I 321 - 250 M 4</b>	62,1 63,3 65,1 65,1
	<b>24,6</b> <b>24,9</b> <b>24,8</b> <b>25</b>	2008 1980 1995 1976	0,9 1,32 1,8 2,24	<b>MR C2I 225 - 250 M 4</b> <b>MR C2I 250 - 250 M 4</b> <b>MR C2I 280 - 250 M 4</b> <b>MR C2I 320 - 250 M 4</b>	56,9 56,1 56,6 56
	<b>26,4</b> <b>26,8</b> <b>26,3</b> <b>27,3</b>	1872 1839 1874 1809	0,95 1,32 1,8 2,36	<b>MR C2I 225 - 250 M 4</b> <b>MR C2I 250 - 250 M 4</b> <b>MR C2I 280 - 250 M 4</b> <b>MR C2I 320 - 250 M 4</b>	53,1 52,1 53,1 51,3
	<b>29,3</b> <b>29,7</b> <b>29,5</b> <b>31,7</b>	1686 1662 1675 1557	1,06 1,5 2,12 2,8	<b>MR C2I 225 - 250 M 4</b> <b>MR C2I 250 - 250 M 4</b> <b>MR C2I 280 - 250 M 4</b> <b>MR C2I 320 - 250 M 4</b>	47,8 47,1 47,5 44,2
	<b>33,8</b> <b>32,7</b> <b>33,7</b>	1460 1511 1465	1,25 1,7 2,36	<b>MR C2I 225 - 250 M 4</b> <b>MR C2I 250 - 250 M 4</b> <b>MR C2I 280 - 250 M 4</b>	41,4 42,8 41,6
	<b>38,6</b> <b>37,6</b> <b>37,3</b>	1278 1314 1324	1,4 2 2,65	<b>MR C2I 225 - 250 M 4</b> <b>MR C2I 250 - 250 M 4</b> <b>MR C2I 280 - 250 M 4</b>	36,2 37,2 37,5
	<b>44,6</b> <b>41,4</b> <b>44,1</b> <b>42,6</b>	1107 1194 1143 1158	1,4 2,12 1,18 2,65	<b>MR C2I 225 - 250 M 4</b> <b>MR C2I 250 - 250 M 4</b> <b>MR CI 250 - 250 M 4</b> <b>MR C2I 280 - 250 M 4</b>	31,4 33,9 31,7 32,8
	<b>50,1</b> <b>56,9</b> <b>55,2</b>	1005 887 914	1,18 1,06 2,12	<b>MR CI 250 - 250 M 4</b> <b>MR CI 200 - 250 M 4</b> <b>MR CI 250 - 250 M 4</b>	27,9 24,6 25,4
	<b>62,7</b> <b>69</b> <b>71,1</b> <b>69</b> <b>68,9</b>	804 731 709 731 731	2,12 0,95 1,5 1,9 2,8	<b>MR CI 250 - 250 M 4</b> <b>MR CI 180 - 250 M 4</b> <b>MR CI 200 - 250 M 4</b> <b>MR CI 225 - 250 M 4</b> <b>MR CI 250 - 250 M 4</b>	22,3 20,3 19,7 20,3 20,3
	<b>75</b> <b>77,8</b> <b>75</b> <b>78,4</b>	672 648 672 644	1,06 1,7 1,9 3,35	<b>MR CI 180 - 250 M 4</b> <b>MR CI 200 - 250 M 4</b> <b>MR CI 225 - 250 M 4</b> <b>MR CI 250 - 250 M 4</b>	18,7 18 18,7 17,9
	<b>87,5</b> <b>84,7</b> <b>87,5</b>	576 595 576	1,25 1,7 2,5	<b>MR CI 180 - 250 M 4</b> <b>MR CI 200 - 250 M 4</b> <b>MR CI 225 - 250 M 4</b>	16 16,5 16
	<b>95,1</b> <b>98,6</b>	530 511	1,4 2,24	<b>MR CI 180 - 250 M 4</b> <b>MR CI 200 - 250 M 4</b>	14,7 14,2
	<b>107</b> <b>107</b> <b>123</b> <b>124</b>	472 470 409 406	1,4 2,36 1,4 2,36	<b>MR CI 180 - 250 M 4</b> <b>MR CI 200 - 250 M 4</b> <b>MR CI 180 - 250 M 4</b> <b>MR CI 200 - 250 M 4</b>	13,1 13 11,4 11,3

P <sub>1</sub> kW 1)	n <sub>2</sub> min <sup>-1</sup>	M <sub>2</sub> daN m	f <sub>s</sub>	Getriebe - Motor Gear reducer - Motor 2)	i
<b>55</b>	<b>137</b> <b>136</b> <b>174</b> <b>217</b>	369 371 290 233	1,4 2,36 2,36 2,36	<b>MR CI 180 - 250 M 4</b> <b>MR CI 200 - 250 M 4</b> <b>MR CI 200 - 250 M 4</b> <b>MR CI 200 - 250 M 4</b>	10,3 10,3 8,06 6,46
<b>75</b>	<b>10,8</b> <b>11</b>	6206 6104	0,85 1	<b>MR C2I 321 - 280 S 4</b> <b>MR C2I 360 - 280 S 4</b>	129 127
	<b>13,6</b> <b>13,6</b> <b>13,8</b>	4964 4964 4883	0,9 1,06 1,4	<b>MR C2I 320 - 280 S 4</b> <b>MR C2I 321 - 280 S 4</b> <b>MR C2I 360 - 280 S 4</b>	103 103 102
	<b>15,8</b> <b>15,8</b> <b>15,3</b>	4273 4273 4395	1,06 1,32 1,6	<b>MR C2I 320 - 280 S 4</b> <b>MR C2I 321 - 280 S 4</b> <b>MR C2I 360 - 280 S 4</b>	88,8 88,8 91,4
	<b>17,4</b> <b>17</b> <b>17</b> <b>17,2</b>	3861 3972 3972 3906	0,9 1,12 1,32 1,8	<b>MR C2I 280 - 280 S 4</b> <b>MR C2I 320 - 280 S 4</b> <b>MR C2I 321 - 280 S 4</b> <b>MR C2I 360 - 280 S 4</b>	80,3 82,6 82,6 81,2
	<b>19,5</b> <b>19,7</b> <b>19,7</b> <b>19,1</b>	3450 3418 3418 3516	1 1,32 1,6 2	<b>MR C2I 280 - 280 S 4</b> <b>MR C2I 320 - 280 S 4</b> <b>MR C2I 321 - 280 S 4</b> <b>MR C2I 360 - 280 S 4</b>	71,7 71,1 71,1 73,1
	<b>22,5</b> <b>22,1</b> <b>21,5</b> <b>21,5</b>	2987 3044 3131 3131	0,85 1,12 1,4 1,7	<b>MR C2I 250 - 280 S 4</b> <b>MR C2I 280 - 280 S 4</b> <b>MR C2I 320 - 280 S 4</b> <b>MR C2I 321 - 280 S 4</b>	62,1 63,3 65,1 65,1
	<b>21,9</b> <b>24,9</b> <b>24,8</b> <b>25</b> <b>25</b> <b>24,3</b>	3080 2700 2720 2695 2695 2772	2,24 0,95 1,32 1,7 2,12 2,5	<b>MR C2I 360 - 280 S 4</b> <b>MR C2I 250 - 280 S 4</b> <b>MR C2I 280 - 280 S 4</b> <b>MR C2I 320 - 280 S 4</b> <b>MR C2I 321 - 280 S 4</b> <b>MR C2I 360 - 280 S 4</b>	64 56,1 56,6 56 56 57,6
	<b>26,8</b> <b>26,3</b> <b>27,3</b> <b>27,3</b> <b>27,7</b>	2508 2556 2467 2467 2427	1 1,32 1,8 2,12 2,8	<b>MR C2I 250 - 280 S 4</b> <b>MR C2I 280 - 280 S 4</b> <b>MR C2I 320 - 280 S 4</b> <b>MR C2I 321 - 280 S 4</b> <b>MR C2I 360 - 280 S 4</b>	52,1 53,1 51,3 51,3 50,5
	<b>29,7</b> <b>29,5</b> <b>31,7</b>	2267 2284 2123	1,12 1,6 2,12	<b>MR C2I 250 - 280 S 4</b> <b>MR C2I 280 - 280 S 4</b> <b>MR C2I 320 - 280 S 4</b>	47,1 47,5 44,2
	<b>32,7</b> <b>33,7</b> <b>35,4</b>	2060 1998 1901	1,25 1,8 2,36	<b>MR C2I 250 - 280 S 4</b> <b>MR C2I 280 - 280 S 4</b> <b>MR C2I 320 - 280 S 4</b>	42,8 41,6 39,5
	<b>37,6</b> <b>37,3</b> <b>38,6</b>	1791 1805 1744	1,4 2 2,65	<b>MR C2I 250 - 280 S 4</b> <b>MR C2I 280 - 280 S 4</b> <b>MR C2I 320 - 280 S 4</b>	37,2 37,5 36,3
	<b>41,4</b> <b>44,1</b> <b>42,6</b> <b>43,1</b>	1628 1558 1579 1561	1,6 0,9 2 2,8	<b>MR C2I 250 - 280 S 4</b> <b>MR CI 250 - 280 S 4</b> <b>MR C2I 280 - 280 S 4</b> <b>MR C2I 320 - 280 S 4</b>	33,9 31,7 32,8 32,5
	<b>50,1</b> <b>55,2</b> <b>62,7</b>	1371 1247 1097	0,9 1,5 1,5	<b>MR CI 250 - 280 S 4</b> <b>MR CI 250 - 280 S 4</b> <b>MR CI 250 - 280 S 4</b>	27,9 25,4 22,3
	<b>71,1</b> <b>69</b> <b>68,9</b> <b>70</b>	967 996 997 982	1,06 1,32 2,12 2,65	<b>MR CI 200 - 280 S 4</b> <b>MR CI 225 - 280 S 4</b> <b>MR CI 250 - 280 S 4</b> <b>MR CI 280 - 280 S 4</b>	19,7 20,3 20,3 20
	<b>77,8</b> <b>75</b> <b>78,4</b>	884 917 878	1,18 1,32 2,36	<b>MR CI 200 - 280 S 4</b> <b>MR CI 225 - 280 S 4</b> <b>MR CI 250 - 280 S 4</b>	18 18,7 17,9
	<b>84,7</b> <b>87,5</b> <b>87,5</b>	812 786 786	1,18 1,8 2,36	<b>MR CI 200 - 280 S 4</b> <b>MR CI 225 - 280 S 4</b> <b>MR CI 250 - 280 S 4</b>	16,5 16 16
	<b>98,6</b> <b>95,1</b>	697 723	1,6 2	<b>MR CI 200 - 280 S 4</b> <b>MR CI 225 - 280 S 4</b>	14,2 14,7
	<b>107</b> <b>109</b>	640 631	1,8 2	<b>MR CI 200 - 280 S 4</b> <b>MR CI 225 - 280 S 4</b>	13 12,8
	<b>124</b> <b>121</b> <b>136</b> <b>140</b>	553 568 506 492	1,8 2 1,8 2	<b>MR CI 200 - 280 S 4</b> <b>MR CI 225 - 280 S 4</b> <b>MR CI 200 - 280 S 4</b> <b>MR CI 225 - 280 S 4</b>	11,3 11,6 10,3 10

1) Leistungen bei Dauerbetrieb S1; bei Betriebsarten S2 ... S10 können sie gesteigert werden (s. Kap. 2b); M<sub>2</sub> steigt und f<sub>s</sub> fällt proportional.  
2) Zur vollständigen Bestellbezeichnung s. Kap. 3.

1) Powers valid for continuous duty S1; increase possible for S2 ... S10 (see ch. 2b); in which case M<sub>2</sub> increases and f<sub>s</sub> decreases proportionately.  
2) For complete designation when ordering see ch. 3.

14 - Herstellungsprogramm (Kegelstirnradgetriebemotoren)  
14 - Manufacturing programme (right angle shafts)

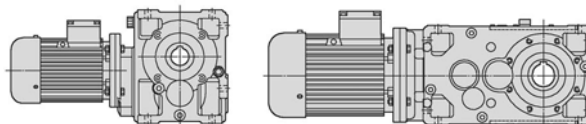

$P_1$ kW 1)	$n_2$ min <sup>-1</sup>	$M_2$ daN m	$f_s$	Getriebe - Motor Gear reducer - Motor 2)	$i$
<b>75</b>	<b>174</b>	396	1,8	MR CI 200 - 280 S 4	8,06
	<b>217</b>	317	1,8	MR CI 200 - 280 S 4	6,46
<b>90</b>	<b>11</b>	7325	0,85	MR C2I 360 - 280 M 4	127
	<b>13,6</b>	5957	0,9	MR C2I 321 - 280 M 4	103
	<b>13,8</b>	5860	1,18	MR C2I 360 - 280 M 4	102
	<b>15,8</b>	5127	0,9	MR C2I 320 - 280 M 4	88,8
	<b>15,8</b>	5127	1,12	MR C2I 321 - 280 M 4	88,8
	<b>15,3</b>	5274	1,32	MR C2I 360 - 280 M 4	91,4
	<b>17</b>	4766	0,9	MR C2I 320 - 280 M 4	82,6
	<b>17</b>	4766	1,12	MR C2I 321 - 280 M 4	82,6
	<b>17,2</b>	4688	1,5	MR C2I 360 - 280 M 4	81,2
	<b>19,5</b>	4140	0,85	MR C2I 280 - 280 M 4	71,7
	<b>19,7</b>	4102	1,12	MR C2I 320 - 280 M 4	71,1
	<b>19,7</b>	4102	1,4	MR C2I 321 - 280 M 4	71,1
	<b>19,1</b>	4219	1,7	MR C2I 360 - 280 M 4	73,1
	<b>22,1</b>	3653	0,95	MR C2I 280 - 280 M 4	63,3
	<b>21,5</b>	3758	1,18	MR C2I 320 - 280 M 4	65,1
	<b>21,5</b>	3758	1,4	MR C2I 321 - 280 M 4	65,1
	<b>21,9</b>	3696	1,9	MR C2I 360 - 280 M 4	64
	<b>24,8</b>	3264	1,06	MR C2I 280 - 280 M 4	56,6
	<b>25</b>	3234	1,4	MR C2I 320 - 280 M 4	56
	<b>25</b>	3234	1,7	MR C2I 321 - 280 M 4	56
	<b>24,3</b>	3327	2,12	MR C2I 360 - 280 M 4	57,6
	<b>26,8</b>	3009	0,85	MR C2I 250 - 280 M 4	52,1
	<b>26,3</b>	3067	1,12	MR C2I 280 - 280 M 4	53,1
	<b>27,3</b>	2961	1,5	MR C2I 320 - 280 M 4	51,3
	<b>27,3</b>	2961	1,8	MR C2I 321 - 280 M 4	51,3
	<b>27,7</b>	2912	2,36	MR C2I 360 - 280 M 4	50,5
	<b>29,7</b>	2720	0,95	MR C2I 250 - 280 M 4	47,1
	<b>29,5</b>	2740	1,32	MR C2I 280 - 280 M 4	47,5
	<b>31,7</b>	2548	1,8	MR C2I 320 - 280 M 4	44,2
	<b>31,7</b>	2548	2,24	MR C2I 321 - 280 M 4	44,2
	<b>30,8</b>	2621	2,65	MR C2I 360 - 280 M 4	45,4
	<b>32,7</b>	2472	1,06	MR C2I 250 - 280 M 4	42,8
	<b>33,7</b>	2398	1,5	MR C2I 280 - 280 M 4	41,6
	<b>35,4</b>	2281	2	MR C2I 320 - 280 M 4	39,5
	<b>35,4</b>	2281	2,5	MR C2I 321 - 280 M 4	39,5
	<b>37,6</b>	2150	1,18	MR C2I 250 - 280 M 4	37,2
	<b>37,3</b>	2166	1,6	MR C2I 280 - 280 M 4	37,5
	<b>38,6</b>	2093	2,12	MR C2I 320 - 280 M 4	36,3
	<b>41,4</b>	1954	1,32	MR C2I 250 - 280 M 4	33,9
	<b>42,6</b>	1895	1,7	MR C2I 280 - 280 M 4	32,8
	<b>43,1</b>	1874	2,36	MR C2I 320 - 280 M 4	32,5
	<b>55,2</b>	1496	1,32	MR CI 250 - 280 M 4	25,4
	<b>62,7</b>	1316	1,32	MR CI 250 - 280 M 4	22,3
	<b>71,1</b>	1161	0,9	MR CI 200 - 280 M 4	19,7
	<b>69</b>	1196	1,12	MR CI 225 - 280 M 4	20,3
	<b>68,9</b>	1197	1,8	MR CI 250 - 280 M 4	20,3
	<b>70</b>	1179	2,24	MR CI 280 - 280 M 4	20
	<b>77,8</b>	1061	1	MR CI 200 - 280 M 4	18
	<b>75</b>	1100	1,12	MR CI 225 - 280 M 4	18,7
	<b>78,4</b>	1053	2	MR CI 250 - 280 M 4	17,9
	<b>77,8</b>	1061	2,24	MR CI 280 - 280 M 4	18
	<b>84,7</b>	974	1	MR CI 200 - 280 M 4	16,5
	<b>87,5</b>	943	1,5	MR CI 225 - 280 M 4	16
	<b>87,5</b>	943	2	MR CI 250 - 280 M 4	16
	<b>88,8</b>	929	3	MR CI 280 - 280 M 4	15,8
	<b>98,6</b>	836	1,32	MR CI 200 - 280 M 4	14,2
	<b>95,1</b>	867	1,7	MR CI 225 - 280 M 4	14,7
	<b>99,4</b>	830	2,65	MR CI 250 - 280 M 4	14,1
	<b>107</b>	768	1,5	MR CI 200 - 280 M 4	13
	<b>109</b>	757	1,7	MR CI 225 - 280 M 4	12,8
	<b>111</b>	744	3	MR CI 250 - 280 M 4	12,6
	<b>124</b>	664	1,5	MR CI 200 - 280 M 4	11,3
<b>121</b>	682	1,7	MR CI 225 - 280 M 4	11,6	
<b>123</b>	672	3	MR CI 250 - 280 M 4	11,4	
<b>136</b>	607	1,5	MR CI 200 - 280 M 4	10,3	
<b>140</b>	590	1,7	MR CI 225 - 280 M 4	10	
<b>135</b>	611	3	MR CI 250 - 280 M 4	10,4	

1) Leistungen bei Dauerbetrieb S1; bei Betriebsarten S2 ... S10 können sie gesteigert werden (s. Kap. 2b);  $M_2$  steigt und  $f_s$  fällt proportional.  
2) Zur vollständigen Bestellbezeichnung s. Kap. 3.

$P_1$ kW 1)	$n_2$ min <sup>-1</sup>	$M_2$ daN m	$f_s$	Getriebe - Motor Gear reducer - Motor 2)	$i$	
<b>90</b>	<b>174</b>	475	1,5	MR CI 200 - 280 M 4	8,06	
	<b>217</b>	381	1,5	MR CI 200 - 280 M 4	6,46	
<b>110</b>	<b>13,8</b>	7162	0,95	MR C2I 360 - 315 S 4	102	
	<b>15,8</b>	6267	0,9	MR C2I 321 - 315 S 4	88,8	
	<b>15,3</b>	6446	1,12	MR C2I 360 - 315 S 4	91,4	
	<b>17</b>	5825	0,9	MR C2I 321 - 315 S 4	82,6	
	<b>17,2</b>	5729	1,18	MR C2I 360 - 315 S 4	81,2	
	<b>19,7</b>	5013	0,9	MR C2I 320 - 315 S 4	71,1	
	<b>19,7</b>	5013	1,12	MR C2I 321 - 315 S 4	71,1	
	<b>19,1</b>	5157	1,4	MR C2I 360 - 315 S 4	73,1	
	<b>21,5</b>	4593	0,95	MR C2I 320 - 315 S 4	65,1	
	<b>21,5</b>	4593	1,18	MR C2I 321 - 315 S 4	65,1	
	<b>21,9</b>	4517	1,5	MR C2I 360 - 315 S 4	64	
	<b>24,8</b>	3989	0,9	MR C2I 280 - 315 S 4	56,6	
	<b>25</b>	3953	1,12	MR C2I 320 - 315 S 4	56	
	<b>25</b>	3953	1,4	MR C2I 321 - 315 S 4	56	
	<b>24,3</b>	4066	1,7	MR C2I 360 - 315 S 4	57,6	
	<b>26,3</b>	3749	0,9	MR C2I 280 - 315 S 4	53,1	
	<b>27,3</b>	3619	1,18	MR C2I 320 - 315 S 4	51,3	
	<b>27,3</b>	3619	1,5	MR C2I 321 - 315 S 4	51,3	
	<b>27,7</b>	3559	1,9	MR C2I 360 - 315 S 4	50,5	
	<b>29,5</b>	3349	1,06	MR C2I 280 - 315 S 4	47,5	
	<b>31,7</b>	3114	1,4	MR C2I 320 - 315 S 4	44,2	
	<b>31,7</b>	3114	1,8	MR C2I 321 - 315 S 4	44,2	
	<b>30,8</b>	3203	2,24	MR C2I 360 - 315 S 4	45,4	
	<b>33,7</b>	2931	1,18	MR C2I 280 - 315 S 4	41,6	
	<b>35,4</b>	2788	1,6	MR C2I 320 - 315 S 4	39,5	
	<b>35,4</b>	2788	2	MR C2I 321 - 315 S 4	39,5	
	<b>34,1</b>	2892	2,5	MR C2I 360 - 315 S 4	41	
	<b>37,3</b>	2647	1,32	MR C2I 280 - 315 S 4	37,5	
	<b>38,6</b>	2558	1,8	MR C2I 320 - 315 S 4	36,3	
	<b>38,6</b>	2558	2,24	MR C2I 321 - 315 S 4	36,3	
	<b>37,5</b>	2631	2,65	MR C2I 360 - 315 S 4	37,3	
	<b>42,6</b>	2316	1,32	MR C2I 280 - 315 S 4	32,8	
	<b>43,1</b>	2290	2	MR C2I 320 - 315 S 4	32,5	
	<b>41,6</b>	2375	2,65	MR C2I 360 - 315 S 4	33,7	
	<b>55,2</b>	1829	1,06	MR CI 250 - 315 S 4	25,4	
	<b>62,7</b>	1609	1,06	MR CI 250 - 315 S 4	22,3	
	<b>69</b>	1461	0,95	MR CI 225 - 315 S 4	20,3	
	<b>68,9</b>	1463	1,4	MR CI 250 - 315 S 4	20,3	
	<b>70</b>	1441	1,9	MR CI 280 - 315 S 4	20	
	<b>75</b>	1345	0,95	MR CI 225 - 315 S 4	18,7	
	<b>78,4</b>	1287	1,7	MR CI 250 - 315 S 4	17,9	
	<b>77,8</b>	1297	1,9	MR CI 280 - 315 S 4	18	
	<b>87,5</b>	1152	1,25	MR CI 225 - 315 S 4	16	
	<b>87,5</b>	1153	1,7	MR CI 250 - 315 S 4	16	
	<b>88,8</b>	1136	2,5	MR CI 280 - 315 S 4	15,8	
	<b>95,1</b>	1060	1,32	MR CI 225 - 315 S 4	14,7	
	<b>99,4</b>	1015	2,24	MR CI 250 - 315 S 4	14,1	
	<b>109</b>	925	1,32	MR CI 225 - 315 S 4	12,8	
	<b>111</b>	909	2,36	MR CI 250 - 315 S 4	12,6	
	<b>121</b>	833	1,32	MR CI 225 - 315 S 4	11,6	
	<b>123</b>	821	2,36	MR CI 250 - 315 S 4	11,4	
	<b>140</b>	722	1,32	MR CI 225 - 315 S 4	10	
	<b>135</b>	746	2,36	MR CI 250 - 315 S 4	10,4	
	<b>132</b>	<b>15,3</b>	7735	0,9	MR C2I 360 - 315 M 4	91,4
		<b>17,2</b>	6875	1	MR C2I 360 - 315 M 4	81,2
		<b>19,7</b>	6016	0,95	MR C2I 321 - 315 M 4	71,1
		<b>19,1</b>	6188	1,12	MR C2I 360 - 315 M 4	73,1
		<b>21,5</b>	5511	0,95	MR C2I 321 - 315 M 4	65,1
		<b>21,9</b>	5421	1,25	MR C2I 360 - 315 M 4	64
		<b>25</b>	4743	0,95	MR C2I 320 - 315 M 4	56
		<b>25</b>	4743	1,18	MR C2I 321 - 315 M 4	56
<b>24,3</b>		4879	1,5	MR C2I 360 - 315 M 4	57,6	
<b>27,3</b>		4342	1	MR C2I 320 - 315 M 4	51,3	
<b>27,3</b>	4342	1,25	MR C2I 321 - 315 M 4	51,3		
<b>27,7</b>	4271	1,6	MR C2I 360 - 315 M 4	50,5		

1) Powers valid for continuous duty S1; increase possible for S2 ... S10 (see ch. 2b); in which case  $M_2$  increases and  $f_s$  decreases proportionately.  
2) For complete designation when ordering see ch. 3.

14 - Herstellungsprogramm (Kegelstirnradgetriebemotoren)  
 14 - Manufacturing programme (right angle shafts)

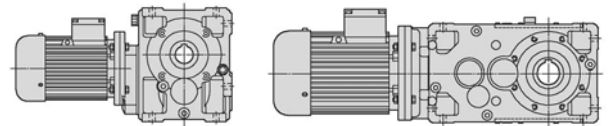

$P_1$ kW	$n_2$ min <sup>-1</sup>	$M_2$ daN m	$f_s$	Getriebe - Motor Gear reducer - Motor	$i$
1)				2)	
<b>132</b>	<b>31,7</b>	3737	1,18	<b>MR C2I 320 - 315 M 4</b>	44,2
	<b>31,7</b>	3737	1,5	<b>MR C2I 321 - 315 M 4</b>	44,2
	<b>30,8</b>	3844	1,8	<b>MR C2I 360 - 315 M 4</b>	45,4
	<b>35,4</b>	3346	1,32	<b>MR C2I 320 - 315 M 4</b>	39,5
	<b>35,4</b>	3346	1,7	<b>MR C2I 321 - 315 M 4</b>	39,5
	<b>34,1</b>	3470	2	<b>MR C2I 360 - 315 M 4</b>	41
	<b>38,6</b>	3070	1,5	<b>MR C2I 320 - 315 M 4</b>	36,3
	<b>38,6</b>	3070	1,8	<b>MR C2I 321 - 315 M 4</b>	36,3
	<b>37,5</b>	3158	2,24	<b>MR C2I 360 - 315 M 4</b>	37,3
	<b>43,1</b>	2748	1,6	<b>MR C2I 320 - 315 M 4</b>	32,5
	<b>43,1</b>	2748	2	<b>MR C2I 321 - 315 M 4</b>	32,5
	<b>41,6</b>	2851	2,24	<b>MR C2I 360 - 315 M 4</b>	33,7
	<b>55,2</b>	2194	0,9	<b>MR CI 250 - 315 M 4</b>	25,4
	<b>62,7</b>	1931	0,9	<b>MR CI 250 - 315 M 4</b>	22,3
	<b>68,9</b>	1755	1,18	<b>MR CI 250 - 315 M 4</b>	20,3
	<b>70</b>	1729	1,5	<b>MR CI 280 - 315 M 4</b>	20
	<b>78,4</b>	1544	1,4	<b>MR CI 250 - 315 M 4</b>	17,9
	<b>77,8</b>	1556	1,5	<b>MR CI 280 - 315 M 4</b>	18
	<b>87,5</b>	1383	1,4	<b>MR CI 250 - 315 M 4</b>	16
	<b>88,8</b>	1363	2,12	<b>MR CI 280 - 315 M 4</b>	15,8
	<b>99,4</b>	1218	1,9	<b>MR CI 250 - 315 M 4</b>	14,1
	<b>98,6</b>	1227	2,24	<b>MR CI 280 - 315 M 4</b>	14,2
	<b>111</b>	1090	2	<b>MR CI 250 - 315 M 4</b>	12,6
	<b>109</b>	1111	2,24	<b>MR CI 280 - 315 M 4</b>	12,9
	<b>123</b>	986	2	<b>MR CI 250 - 315 M 4</b>	11,4
	<b>122</b>	993	2,24	<b>MR CI 280 - 315 M 4</b>	11,5
<b>135</b>	896	2	<b>MR CI 250 - 315 M 4</b>	10,4	
<b>139</b>	869	2,24	<b>MR CI 280 - 315 M 4</b>	10,1	

$P_1$ kW	$n_2$ min <sup>-1</sup>	$M_2$ daN m	$f_s$	Getriebe - Motor Gear reducer - Motor	$i$
1)				2)	
<b>160</b>	<b>17,2</b>	8334	0,85	<b>MR C2I 360 - 315 MC 4</b>	81,2
	<b>19,1</b>	7500	0,95	<b>MR C2I 360 - 315 MC 4</b>	73,1
	<b>21,9</b>	6571	1,06	<b>MR C2I 360 - 315 MC 4</b>	64
	<b>25</b>	5750	0,95	<b>MR C2I 321 - 315 MC 4</b>	56
	<b>24,3</b>	5914	1,18	<b>MR C2I 360 - 315 MC 4</b>	57,6
	<b>27,3</b>	5263	0,85	<b>MR C2I 320 - 315 MC 4</b>	51,3
	<b>27,3</b>	5263	1	<b>MR C2I 321 - 315 MC 4</b>	51,3
	<b>27,7</b>	5177	1,32	<b>MR C2I 360 - 315 MC 4</b>	50,5
	<b>31,7</b>	4530	1	<b>MR C2I 320 - 315 MC 4</b>	44,2
	<b>31,7</b>	4530	1,25	<b>MR C2I 321 - 315 MC 4</b>	44,2
	<b>30,8</b>	4659	1,5	<b>MR C2I 360 - 315 MC 4</b>	45,4
	<b>35,4</b>	4055	1,12	<b>MR C2I 320 - 315 MC 4</b>	39,5
	<b>35,4</b>	4055	1,4	<b>MR C2I 321 - 315 MC 4</b>	39,5
	<b>34,1</b>	4206	1,7	<b>MR C2I 360 - 315 MC 4</b>	41
	<b>38,6</b>	3721	1,18	<b>MR C2I 320 - 315 MC 4</b>	36,3
	<b>38,6</b>	3721	1,5	<b>MR C2I 321 - 315 MC 4</b>	36,3
	<b>37,5</b>	3827	1,9	<b>MR C2I 360 - 315 MC 4</b>	37,3
	<b>43,1</b>	3331	1,32	<b>MR C2I 320 - 315 MC 4</b>	32,5
	<b>43,1</b>	3331	1,7	<b>MR C2I 321 - 315 MC 4</b>	32,5
	<b>41,6</b>	3455	1,9	<b>MR C2I 360 - 315 MC 4</b>	33,7
	<b>70</b>	2096	1,25	<b>MR CI 280 - 315 MC 4</b>	20
	<b>77,8</b>	1886	1,25	<b>MR CI 280 - 315 MC 4</b>	18
	<b>88,8</b>	1652	1,7	<b>MR CI 280 - 315 MC 4</b>	15,8
	<b>98,6</b>	1487	1,9	<b>MR CI 280 - 315 MC 4</b>	14,2
	<b>109</b>	1347	1,9	<b>MR CI 280 - 315 MC 4</b>	12,9
	<b>122</b>	1204	1,9	<b>MR CI 280 - 315 MC 4</b>	11,5
<b>139</b>	1053	1,9	<b>MR CI 280 - 315 MC 4</b>	10,1	

1) Leistungen bei Dauerbetrieb S1; bei Betriebsarten S2 ... S10 können sie **gesteigert** werden (s. Kap. 2b);  $M_2$  steigt und  $f_s$  fällt proportional.  
 2) Zur vollständigen Bestellbezeichnung s. Kap. 3.

1) Powers valid for continuous duty S1; **increase** possible for S2 ... S10 (see ch. 2b); in which case  $M_2$  increases and  $f_s$  decreases proportionately.  
 2) For complete designation when ordering see ch. 3.

**15 - Herstellungsprogramm (Kegelstirnradgetriebemotoren für Fahrtrieb)**  
**15 - Manufacturing programme (right angle shafts for traverse movements)**  
 2.4 pol.

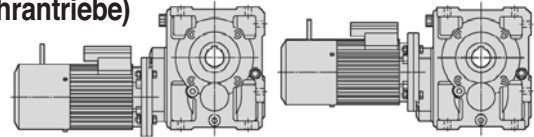

P <sub>1</sub> kW	n <sub>2</sub> min <sup>-1</sup>	M <sub>2</sub> daN m	f <sub>s min</sub> bei / at n <sub>2</sub> min	Getriebe - Motor Gear reducer - Motor	i		
1)							
2)							
0,18 - 0,12	20,7 - 10,4	7,6 - 10,2	1,6	MR C3I 50 - FVO 63 A	2,4	135	
	33,2 - 16,6	4,87 - 6,5	2,24	MR ICI 50 - FVO 63 A	2,4	84,3	
	41,5 - 20,8	3,89 - 5,2	2,8	MR ICI 50 - FVO 63 A	2,4	67,5	
3)	51 - 25,5	3,17 - 4,23	>3	MR ICI 50 - FVO 63 A	2,4	54,9	
	64,7 - 32,3	2,5 - 3,33	>3	MR ICI 50 - FVO 63 A	2,4	43,3	
	116 - 58,1	1,42 - 1,89	>3	MR CI 50 - FVO 63 A	2,4	24,1	
0,25 - 0,18	21,9 - 11	10 - 14,4	2,24	MR C3I 63 - FVO 71 A	2,4	128	
	21,9 - 11	10 - 14,4	2,65	MR C3I 63 - FVO 71 A	2,4	128	
	23,6 - 11,8	9,5 - 13,7	1,6	MR ICI 64 - FVO 71 A	2,4	119	
3)	23,6 - 11,8	9,5 - 13,7	2,12	MR ICI 64 - FVO 71 A	2,4	119	
	28,6 - 14,3	7,7 - 11,1	1,5	MR C3I 50 - FVO 71 A	2,4	97,9	
	29,5 - 14,7	7,6 - 11	2,5	MR ICI 63 - FVO 71 A	2,4	95	
	33,2 - 16,6	6,8 - 9,7	1,5	MR ICI 50 - FVO 63 B	2,4	84,3	
	35,2 - 17,6	6,4 - 9,2	3	MR ICI 63 - FVO 71 A	2,4	79,5	
	41,5 - 20,8	5,4 - 7,8	1,9	MR ICI 50 - FVO 63 B	2,4	67,5	
	44 - 22	5,1 - 7,3	>3	MR ICI 63 - FVO 71 A	2,4	63,6	
	45,8 - 22,9	4,9 - 7,1	2	MR ICI 50 - FVO 71 A	2,4	61,1	
	51 - 25,5	4,4 - 6,3	2,65	MR ICI 50 - FVO 63 B	2,4	54,9	
	55 - 27,5	4,08 - 5,9	>3	MR ICI 63 - FVO 71 A	2,4	50,9	
	57,3 - 28,6	3,92 - 5,6	2,65	MR ICI 50 - FVO 71 A	2,4	48,9	
	64,7 - 32,3	3,47 - 5	>3	MR ICI 50 - FVO 63 B	2,4	43,3	
	70,4 - 35,2	3,19 - 4,59	>3	MR ICI 50 - FVO 71 A	2,4	39,8	
	89,2 - 44,6	2,51 - 3,62	>3	MR ICI 50 - FVO 71 A	2,4	31,4	
	89,6 - 44,8	2,56 - 3,68	>3	MR CI 63 - FVO 71 A	2,4	31,3	
	116 - 58,1	1,97 - 2,84	>3	MR CI 50 - FVO 63 B	2,4	24,1	
	116 - 58,1	1,97 - 2,84	>3	MR CI 50 - FVO 71 A	2,4	24,1	
	145 - 72,6	1,58 - 2,27	>3	MR CI 50 - FVO 63 B	2,4	19,3	
	145 - 72,6	1,58 - 2,27	>3	MR CI 50 - FVO 71 A	2,4	19,3	
	178 - 89,2	1,28 - 1,85	>3	MR CI 50 - FVO 63 B	2,4	15,7	
	178 - 89,2	1,28 - 1,85	>3	MR CI 50 - FVO 71 A	2,4	15,7	
	226 - 113	1,01 - 1,46	>3	MR CI 50 - FVO 63 B	2,4	12,4	
	226 - 113	1,01 - 1,46	>3	MR CI 50 - FVO 71 A	2,4	12,4	
	272 - 136	0,84 - 1,21	>3	MR CI 50 - FVO 63 B	2,4	10,3	
	272 - 136	0,84 - 1,21	>3	MR CI 50 - FVO 71 A	2,4	10,3	
	0,37 - 0,25	21 - 10,5	15,4 - 20,9	>3	MRC3I 80 - FVO 71 B	2,4	133
		21,9 - 11	14,8 - 20	1,6	MRC3I 63 - FVO 71 B	2,4	128
21,9 - 11		14,8 - 20	1,9	MRC3I 64 - FVO 71 B	2,4	128	
3)	23,6 - 11,8	14,1 - 19	1,5	MR ICI 64 - FVO 71 B	2,4	119	
	29,5 - 14,7	11,3 - 15,2	1,8	MR ICI 63 - FVO 71 B	2,4	95	
	29,5 - 14,7	11,3 - 15,2	2,24	MR ICI 64 - FVO 71 B	2,4	95	
	35,2 - 17,6	9,4 - 12,8	2,12	MR ICI 63 - FVO 71 B	2,4	79,5	
	35,2 - 17,6	9,4 - 12,8	2,65	MR ICI 64 - FVO 71 B	2,4	79,5	
	44 - 22	7,5 - 10,2	2,65	MR ICI 63 - FVO 71 B	2,4	63,6	
	45,8 - 22,9	7,2 - 9,8	1,5	MR ICI 50 - FVO 71 B	2,4	61,1	
	55 - 27,5	6 - 8,2	>3	MR ICI 63 - FVO 71 B	2,4	50,9	
	57,3 - 28,6	5,8 - 7,8	1,9	MR ICI 50 - FVO 71 B	2,4	48,9	
	70,4 - 35,2	4,72 - 6,4	2,65	MR ICI 50 - FVO 71 B	2,4	39,8	
	89,2 - 44,6	3,72 - 5	>3	MR ICI 50 - FVO 71 B	2,4	31,4	
	89,6 - 44,8	3,79 - 5,1	>3	MR CI 63 - FVO 71 B	2,4	31,3	
	116 - 58,1	2,92 - 3,94	>3	MR CI 50 - FVO 71 B	2,4	24,1	
	145 - 72,6	2,33 - 3,16	>3	MR CI 50 - FVO 71 B	2,4	19,3	
	178 - 89,2	1,9 - 2,57	>3	MR CI 50 - FVO 71 B	2,4	15,7	
	226 - 113	1,5 - 2,03	>3	MR CI 50 - FVO 71 B	2,4	12,4	
	272 - 136	1,25 - 1,69	>3	MR CI 50 - FVO 71 B	2,4	10,3	
	0,55 - 0,37	20,8 - 10,4	23,2 - 31,3	2	MRC3I 80 - FVO 80 A	2,4	135
20,8 - 10,4		23,2 - 31,3	2,24	MRC3I 81 - FVO 80 A	2,4	135	
21 - 10,5		23 - 30,9	2,12	MRC3I 80 - FVO 71 C	2,4	133	
3)	21 - 10,5	23 - 30,9	2,5	MR C3I 81 - FVO 71 C	2,4	133	
	21,9 - 11	22 - 29,7	1,32	MR C3I 64 - FVO 71 C	2,4	128	
	22,4 - 11,2	21,6 - 29,1	>3	MRC3I 100 - FVO 80 A	2,4	125	
	26,4 - 13,2	18,3 - 24,6	2,65	MRC3I 80 - FVO 80 A	2,4	106	
	27,5 - 13,7	17,6 - 23,7	1,32	MRC3I 63 - FVO 80 A	2,4	102	
	27,5 - 13,7	17,6 - 23,7	1,6	MRC3I 64 - FVO 80 A	2,4	102	
	29,5 - 14,7	16,8 - 22,5	1,5	MR ICI 64 - FVO 71 C	2,4	95	
	33,9 - 17	14,5 - 19,6	2,5	MR ICI 80 - FVO 80 A	2,4	82,5	
	35,2 - 17,6	14 - 18,9	1,4	MR ICI 63 - FVO 71 C	2,4	79,5	

P <sub>1</sub> kW	n <sub>2</sub> min <sup>-1</sup>	M <sub>2</sub> daN m	f <sub>s min</sub> bei / at n <sub>2</sub> min	Getriebe - Motor Gear reducer - Motor	i	
1)						
2)						
0,55 - 0,37	35,2 - 17,6	14 - 18,9	1,8	MR ICI 64 - FVO 71 C	2,4	79,5
	35,3 - 17,6	14 - 18,8	1,5	MR ICI 64 - FVO 80 A	2,4	79,3
	42,4 - 21,2	11,6 - 15,7	>3	MR ICI 80 - FVO 80 A	2,4	66
3)	44 - 22	11,2 - 15,1	1,8	MR ICI 63 - FVO 71 C	2,4	63,6
	44 - 22	11,2 - 15,1	2,24	MR ICI 64 - FVO 71 C	2,4	63,6
	44,1 - 22,1	11,2 - 15,1	1,8	MR ICI 63 - FVO 80 A	2,4	63,5
	44,1 - 22,1	11,2 - 15,1	2,24	MR ICI 64 - FVO 80 A	2,4	63,5
	53 - 26,5	9,3 - 12,5	>3	MR ICI 80 - FVO 80 A	2,4	52,8
	55 - 27,5	9 - 12,1	2,36	MR ICI 63 - FVO 71 C	2,4	50,9
	55 - 27,5	9 - 12,1	2,8	MR ICI 64 - FVO 71 C	2,4	50,9
	55,2 - 27,6	9 - 12	2,24	MR ICI 63 - FVO 80 A	2,4	50,8
	55,2 - 27,6	9 - 12	2,8	MR ICI 64 - FVO 80 A	2,4	50,8
	68,9 - 34,5	7,2 - 9,6	3	MR ICI 63 - FVO 80 A	2,4	40,6
	70,4 - 35,2	7 - 9,4	1,7	MR ICI 50 - FVO 71 C	2,4	39,8
	71,6 - 35,8	6,9 - 9,3	1,6	MR ICI 50 - FVO 80 A	2,4	39,1
	86,2 - 43,1	5,9 - 7,9	>3	MR CI 80 - FVO 80 A	2,4	32,5
	87,4 - 43,7	5,6 - 7,6	>3	MR ICI 63 - FVO 80 A	2,4	32
	87,9 - 43,9	5,6 - 7,6	2,12	MR ICI 50 - FVO 80 A	2,4	31,9
	89,2 - 44,6	5,5 - 7,4	2,24	MR ICI 50 - FVO 71 C	2,4	31,4
	89,6 - 44,8	5,6 - 7,6	2,8	MR CI 63 - FVO 71 C	2,4	31,3
	89,6 - 44,8	5,6 - 7,6	2,8	MR CI 63 - FVO 80 A	2,4	31,3
	111 - 55,7	4,43 - 6	2,8	MR ICI 50 - FVO 80 A	2,4	25,1
	112 - 56	4,5 - 6,1	>3	MR CI 63 - FVO 71 C	2,4	25
	112 - 56	4,5 - 6,1	>3	MR CI 63 - FVO 80 A	2,4	25
	116 - 58,1	4,34 - 5,8	2,36	MR CI 50 - FVO 71 C	2,4	24,1
	116 - 58,1	4,34 - 5,8	2,36	MR CI 50 - FVO 80 A	2,4	24,1
	134 - 66,9	3,69 - 4,96	>3	MR ICI 50 - FVO 80 A	2,4	20,9
	140 - 70	3,6 - 4,85	>3	MR CI 63 - FVO 80 A	2,4	20
	145 - 72,6	3,47 - 4,67	3	MR CI 50 - FVO 71 C	2,4	19,3
	145 - 72,6	3,47 - 4,67	3	MR CI 50 - FVO 80 A	2,4	19,3
	175 - 87,5	2,88 - 3,88	>3	MR CI 63 - FVO 80 A	2,4	16
	178 - 89,2	2,83 - 3,8	>3	MR CI 50 - FVO 71 C	2,4	15,7
	178 - 89,2	2,83 - 3,8	>3	MR CI 50 - FVO 80 A	2,4	15,7
	222 - 111	2,27 - 3,06	>3	MR CI 63 - FVO 80 A	2,4	12,6
	226 - 113	2,23 - 3	>3	MR CI 50 - FVO 71 C	2,4	12,4
	226 - 113	2,23 - 3	>3	MR CI 50 - FVO 80 A	2,4	12,4
	270 - 135	1,87 - 2,51	>3	MR CI 63 - FVO 80 A	2,4	10,4
	272 - 136	1,86 - 2,5	>3	MR CI 50 - FVO 71 C	2,4	10,3
	272 - 136	1,86 - 2,5	>3	MR CI 50 - FVO 80 A	2,4	10,3
0,75 - 0,55	20,8 - 10,4	31,7 - 46,5	1,4	MR C3I 80 - FVO 80 B	2,4	135
	20,8 - 10,4	31,7 - 46,5	1,5	MR C3I 81 - FVO 80 B	2,4	135
	22,4 - 11,2	29,5 - 43,2	>3	MR C3I 100 - FVO 80 B	2,4	125
	26,4 - 13,2	25 - 36,6	1,8	MR C3I 80 - FVO 80 B	2,4	106
	26,4 - 13,2	25 - 36,6	2,12	MR C3I 81 - FVO 80 B	2,4	106
	33,9 - 17	19,8 - 29,1	1,7	MR ICI 80 - FVO 80 B	2,4	82,5
	33,9 - 17	19,8 - 29,1	1,9	MR ICI 81 - FVO 80 B	2,4	82,5
	42,4 - 21,2	15,9 - 23,3	2,5	MR ICI 80 - FVO 80 B	2,4	66
	44,1 - 22,1	15,3 - 22,4	1,5	MR ICI 64 - FVO 80 B	2,4	63,5
	53 - 26,5	12,7 - 18,6	>3	MR ICI 80 - FVO 80 B	2,4	52,8
	55,2 - 27,6	12,2 - 17,9	1,5	MR ICI 63 - FVO 80 B	2,4	50,8
	55,2 - 27,6	12,2 - 17,9	1,9	MR ICI 64 - FVO 80 B	2,4	50,8
	66,2 - 33,1	10,2 - 14,9	>3	MR ICI 80 - FVO 80 B	2,4	42,3
	68,9 - 34,5	9,8 - 14,3	2	MR ICI 63 - FVO 80 B	2,4	40,6
	68,9 - 34,5	9,8 - 14,3	2,36	MR ICI 64 - FVO 80 B	2,4	40,6
	86,2 - 43,1	8 - 11,7	>3	MR CI 80 - FVO 80 B	2,4	32,5
	87,4 - 43,7	7,7 - 11,3	2,8	MR ICI 63 - FVO 80 B	2,4	32
	87,9 - 43,9	7,7 - 11,2	1,5	MR ICI 50 - FVO 80 B	2,4	31,9
	89,6 - 44,8	7,7 - 11,3	1,9	MR CI 63 - FVO 80 B	2,4	31,3
	89,6 - 44,8	7,7 - 11,3	2,12	MR CI 64 - FVO 80 B	2,4	31,3
	111 - 55,7	6 - 8,9	1,9	MR ICI 50 - FVO 80 B	2,4	25,1
	112 - 56	6,1 - 9	3	MR CI 63 - FVO 80 B	2,4	25
	116 - 58,1	5,9 - 8,7	1,6	MR CI 50 - FVO 80 B	2,4	24,1
	134 - 66,9	5 - 7,4	2,12	MR ICI 50 - FVO 80 B	2,4	20,9
	140 - 70	4,91 - 7,2	>3	MR CI 63 - FVO 80 B	2,4	20
	145 - 72,6	4,73 - 6,9	2	MR CI 50 - FVO 80 B	2,4	19,3
	175 - 87,5	3,93 - 5,8	>3	MR CI 63 - FVO 80 B	2,4	16
178 - 89,2	3,85 - 5,7	2,5	MR CI 50 - FVO 80 B	2,4	15,7	

1) Leistungen bei Dauerbetrieb S1; bei Betriebsarten S2 ... S10 können sie **gesteigert** werden (s. Kap. 2b); M<sub>2</sub> steigt und f<sub>s</sub> fällt proportional; bitte rückfragen.  
 2) Zur vollständigen Bestellbezeichnung s. Kap. 3. Auch **F0**-Ausführung «Normal-bremsmotor» vorgesehen.  
 3) Auch Getriebegröße **40** zur Verfügung; bitte rückfragen.  
 Bei der Bestimmung des Betriebsfaktors, **b** oder **c** als Belastung annehmen (Kap. 5).

1) Powers valid for continuous duty S1; **increase** possible for S2 ... S10 (see ch. 2b); in which case M<sub>2</sub> increases and f

15 - Herstellungsprogramm (Kegelstirradgetriebemotoren für Fahrtriebe)  
 15 - Manufacturing programme (right angle shafts for traverse movements)  
 2.4 pol.

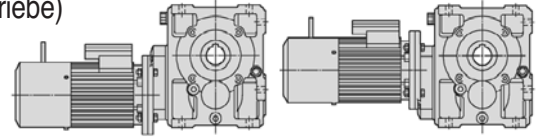

$P_1$ kW	$n_2$ min <sup>-1</sup>	$M_2$ daN m	$f_s$ <sub>min</sub> bei / at $n_2$ min	Getriebe - Motor Gear reducer - Motor	$i$
0,75	222 - 111	3,1 - 4,54	> 3	MR CI 63 - FV0 80 B	2,4 12,6
0,55	226 - 113	3,04 - 4,46	> 3	MR CI 50 - FV0 80 B	2,4 12,4
	270 - 135	2,54 - 3,73	> 3	MR CI 63 - FV0 80 B	2,4 10,4
	272 - 136	2,53 - 3,71	> 3	MR CI 50 - FV0 80 B	2,4 10,3
1,1	22,1 - 11	43,7 - 60	2,24	MRC3I 100 - FV0 90 S	2,4 127
0,75	22,4 - 11,2	43,2 - 59	2,36	MRC3I 100 - FV0 80 C	2,4 125
	22,7 - 11,4	42,5 - 58	> 3	MRC3I 125 - FV0 90 S	2,4 123
	26,4 - 13,2	36,6 - 50	1,32	MR C3I 80 - FV0 80 C	2,4 106
	26,4 - 13,2	36,6 - 50	1,6	MR C3I 81 - FV0 80 C	2,4 106
	28 - 14	34,5 - 47	3	MR C3I 100 - FV0 90 S	2,4 99,9
	30,1 - 15,1	32,8 - 44,7	2,5	MR ICI 100 - FV0 90 S	2,4 92,9
	33,9 - 17	29,1 - 39,7	1,25	MR ICI 80 - FV0 80 C	2,4 82,5
	33,9 - 17	29,1 - 39,7	1,4	MR ICI 81 - FV0 80 C	2,4 82,5
	36,6 - 18,3	27 - 36,8	2,5	MR ICI 100 - FV0 90 S	2,4 76,4
	42,4 - 21,2	23,3 - 31,7	1,8	MR ICI 80 - FV0 80 C	2,4 66
	42,4 - 21,2	23,3 - 31,7	2,12	MR ICI 81 - FV0 80 C	2,4 66
	43,1 - 21,5	22,9 - 31,3	1,6	MR ICI 80 - FV0 90 S	2,4 65
	43,1 - 21,5	22,9 - 31,3	1,7	MR ICI 81 - FV0 90 S	2,4 65
	45,8 - 22,9	21,6 - 29,4	> 3	MR ICI 100 - FV0 90 S	2,4 61,2
	53 - 26,5	18,6 - 25,4	2,24	MR ICI 80 - FV0 80 C	2,4 52,8
	53 - 26,5	18,6 - 25,4	2,65	MR ICI 81 - FV0 80 C	2,4 52,8
	53,8 - 26,9	18,3 - 25	2,36	MR ICI 80 - FV0 90 S	2,4 52
	53,8 - 26,9	18,3 - 25	2,65	MR ICI 81 - FV0 90 S	2,4 52
	55,2 - 27,6	17,9 - 24,4	1,4	MR ICI 64 - FV0 80 C	2,4 50,8
	56 - 28	17,6 - 24	1,4	MR ICI 64 - FV0 90 S	2,4 50
	57,2 - 28,6	17,3 - 23,5	> 3	MR ICI 100 - FV0 90 S	2,4 48,9
	66,2 - 33,1	14,9 - 20,3	3	MR ICI 80 - FV0 80 C	2,4 42,3
	67,3 - 33,7	14,7 - 20	2,8	MR ICI 80 - FV0 90 S	2,4 41,6
	68,9 - 34,5	14,3 - 19,5	1,4	MR ICI 63 - FV0 80 C	2,4 40,6
	68,9 - 34,5	14,3 - 19,5	1,7	MR ICI 64 - FV0 80 C	2,4 40,6
	70 - 35	14,1 - 19,2	1,4	MR ICI 63 - FV0 90 S	2,4 40
	70 - 35	14,1 - 19,2	1,7	MR ICI 64 - FV0 90 S	2,4 40
	76,5 - 38,2	13,2 - 18	> 3	MR CI 100 - FV0 90 S	2,4 36,6
	84 - 42	11,8 - 16	> 3	MR ICI 80 - FV0 90 S	2,4 33,3
	86,2 - 43,1	11,7 - 16	2,65	MR CI 80 - FV0 80 C	2,4 32,5
	86,2 - 43,1	11,7 - 16	2,65	MR CI 80 - FV0 90 S	2,4 32,5
	87,4 - 43,7	11,3 - 15,4	2	MR ICI 63 - FV0 80 C	2,4 32
	87,4 - 43,7	11,3 - 15,4	2,5	MR ICI 64 - FV0 80 C	2,4 32
	87,5 - 43,8	11,3 - 15,4	1,8	MR ICI 63 - FV0 90 S	2,4 32
	87,5 - 43,8	11,3 - 15,4	2,12	MR ICI 64 - FV0 90 S	2,4 32
	89,6 - 44,8	11,3 - 15,3	1,32	MR CI 63 - FV0 80 C	2,4 31,3
	89,6 - 44,8	11,3 - 15,3	1,6	MR CI 64 - FV0 80 C	2,4 31,3
	89,6 - 44,8	11,3 - 15,3	1,32	MR CI 63 - FV0 90 S	2,4 31,3
	89,6 - 44,8	11,3 - 15,3	1,6	MR CI 64 - FV0 90 S	2,4 31,3
	108 - 53,8	9,4 - 12,8	> 3	MR CI 80 - FV0 80 C	2,4 26
	108 - 53,8	9,4 - 12,8	> 3	MR CI 80 - FV0 90 S	2,4 26
	111 - 55,5	8,9 - 12,1	2,65	MR ICI 63 - FV0 90 S	2,4 25,2
	112 - 56	9 - 12,3	2,24	MR CI 63 - FV0 80 C	2,4 25
	112 - 56	9 - 12,3	2,65	MR CI 64 - FV0 80 C	2,4 25
	112 - 56	9 - 12,3	2,24	MR CI 63 - FV0 90 S	2,4 25
	112 - 56	9 - 12,3	2,65	MR CI 64 - FV0 90 S	2,4 25
	135 - 67,3	7,5 - 10,2	> 3	MR CI 80 - FV0 90 S	2,4 20,8
	135 - 67,6	7,3 - 10	2,65	MR ICI 63 - FV0 90 S	2,4 20,7
	140 - 70	7,2 - 9,8	2,65	MR CI 63 - FV0 80 C	2,4 20
	140 - 70	7,2 - 9,8	2,65	MR CI 63 - FV0 90 S	2,4 20
	175 - 87,5	5,8 - 7,9	> 3	MR CI 63 - FV0 80 C	2,4 16
	175 - 87,5	5,8 - 7,9	> 3	MR CI 63 - FV0 90 S	2,4 16
	222 - 111	4,54 - 6,2	> 3	MR CI 63 - FV0 80 C	2,4 12,6
	222 - 111	4,54 - 6,2	> 3	MR CI 63 - FV0 90 S	2,4 12,6
	270 - 135	3,73 - 5,1	> 3	MR CI 63 - FV0 80 C	2,4 10,4
	270 - 135	3,73 - 5,1	> 3	MR CI 63 - FV0 90 S	2,4 10,4
1,5	22,1 - 11	60 - 87	1,5	MRC3I 100 - FV0 90 LA	2,4 127
1,1	22,7 - 11,4	58 - 85	> 3	MRC3I 125 - FV0 90 LA	2,4 123
	28 - 14	47 - 69	2	MRC3I 100 - FV0 90 LA	2,4 99,9
	30,1 - 15,1	44,7 - 66	1,7	MR ICI 100 - FV0 90 LA	2,4 92,9
	36,6 - 18,3	36,8 - 54	1,7	MR ICI 100 - FV0 90 LA	2,4 76,4

$P_1$ kW	$n_2$ min <sup>-1</sup>	$M_2$ daN m	$f_s$ <sub>min</sub> bei / at $n_2$ min	Getriebe - Motor Gear reducer - Motor	$i$
1,5	45,8 - 22,9	29,4 - 43,1	2,8	MR ICI 100 - FV0 90 LA	2,4 61,2
0,1	53,8 - 26,9	25 - 36,7	1,6	MR ICI 80 - FV0 90 LA	2,4 52
	53,8 - 26,9	25 - 36,7	1,8	MR ICI 81 - FV0 90 LA	2,4 52
	57,2 - 28,6	23,5 - 34,5	> 3	MR CI 100 - FV0 90 LA	2,4 48,9
	67,3 - 33,7	20 - 29,3	2	MR ICI 80 - FV0 90 LA	2,4 41,6
	67,3 - 33,7	20 - 29,3	2,24	MR ICI 81 - FV0 90 LA	2,4 41,6
	70,3 - 35,1	19,2 - 28,1	> 3	MR CI 100 - FV0 90 LA	2,4 39,8
	76,5 - 38,2	18 - 26,4	> 3	MR CI 100 - FV0 90 LA	2,4 36,6
	84 - 42	16 - 23,5	2,65	MR ICI 80 - FV0 90 LA	2,4 33,3
	86,2 - 43,1	16 - 23,4	1,9	MR CI 80 - FV0 90 LA	2,4 32,5
	86,2 - 43,1	16 - 23,4	2,24	MR CI 81 - FV0 90 LA	2,4 32,5
	87,5 - 43,8	15,4 - 22,6	1,5	MR ICI 64 - FV0 90 LA	2,4 32
	93 - 46,5	14,8 - 21,7	> 3	MR CI 100 - FV0 90 LA	2,4 30,1
	107 - 53,3	12,6 - 18,5	> 3	MR ICI 80 - FV0 90 LA	2,4 26,3
	108 - 53,8	12,8 - 18,7	3	MR CI 80 - FV0 90 LA	2,4 26
	111 - 55,5	12,1 - 17,8	1,8	MR ICI 63 - FV0 90 LA	2,4 25,2
	111 - 55,5	12,1 - 17,8	2,12	MR ICI 64 - FV0 90 LA	2,4 25,2
	112 - 56	12,3 - 18	1,5	MR CI 63 - FV0 90 LA	2,4 25
	112 - 56	12,3 - 18	1,8	MR CI 64 - FV0 90 LA	2,4 25
	135 - 67,3	10,2 - 15	> 3	MR CI 80 - FV0 90 LA	2,4 20,8
	135 - 67,6	10 - 14,6	1,8	MR ICI 63 - FV0 90 LA	2,4 20,7
	135 - 67,6	10 - 14,6	2,12	MR ICI 64 - FV0 90 LA	2,4 20,7
	140 - 70	9,8 - 14,4	1,9	MR CI 63 - FV0 90 LA	2,4 20
	140 - 70	9,8 - 14,4	2,24	MR CI 64 - FV0 90 LA	2,4 20
	142 - 70,8	9,5 - 13,9	> 3	MR ICI 80 - FV0 90 LA	2,4 19,8
	168 - 84	8,2 - 12	> 3	MR CI 80 - FV0 90 LA	2,4 16,7
	175 - 87,5	7,9 - 11,5	2,24	MR CI 63 - FV0 90 LA	2,4 16
	175 - 87,5	7,9 - 11,5	2,8	MR CI 64 - FV0 90 LA	2,4 16
	222 - 111	6,2 - 9,1	> 3	MR CI 63 - FV0 90 LA	2,4 12,6
	270 - 135	5,1 - 7,5	> 3	MR CI 63 - FV0 90 LA	2,4 10,4
	351 - 175	3,92 - 5,7	> 3	MR CI 63 - FV0 90 LA	2,4 7,98
	444 - 222	3,1 - 4,54	> 3	MR CI 63 - FV0 90 LA	2,4 6,31
2,2	22,1 - 11	88 - 119	2,24	MRC3I 125 - FV0 100 LA	2,4 127
1,5	22,7 - 11,4	85 - 116	2,36	MRC3I 125 - FV0 90 LB	2,4 123
	28 - 14	69 - 94	3	MRC3I 125 - FV0 100 LA	2,4 100
	28 - 14	69 - 94	1,5	MRC3I 100 - FV0 90 LB	2,4 99,9
	28,7 - 14,3	69 - 94	2,36	MR ICI 125 - FV0 100 LA	2,4 97,7
	35,8 - 17,9	55 - 75	> 3	MR ICI 125 - FV0 100 LA	2,4 78,1
	38,2 - 19,1	52 - 70	1,5	MR ICI 100 - FV0 100 LA	2,4 73,2
	44,2 - 22,1	44,7 - 61	> 3	MR ICI 125 - FV0 100 LA	2,4 63,4
	45,8 - 22,9	43,1 - 59	2,12	MR ICI 100 - FV0 90 LB	2,4 61,2
	46,5 - 23,2	42,5 - 58	1,6	MR ICI 100 - FV0 100 LA	2,4 60,2
	53,8 - 26,9	36,7 - 50	1,32	MR ICI 81 - FV0 90 LB	2,4 52
	55,2 - 27,6	35,8 - 48,8	> 3	MR ICI 125 - FV0 100 LA	2,4 50,7
	57,2 - 28,6	34,5 - 47,1	2,65	MR ICI 100 - FV0 90 LB	2,4 48,9
	58,1 - 29,1	34 - 46,3	2,65	MR ICI 100 - FV0 100 LA	2,4 48,2
	67,3 - 33,7	29,3 - 40	1,4	MR ICI 80 - FV0 90 LB	2,4 41,6
	67,3 - 33,7	29,3 - 40	1,7	MR ICI 81 - FV0 90 LB	2,4 41,6
	70,3 - 35,1	28,1 - 38,3	> 3	MR ICI 100 - FV0 90 LB	2,4 39,8
	72,6 - 36,3	27,2 - 37,1	> 3	MR ICI 100 - FV0 100 LA	2,4 38,5
	76,5 - 38,2	26,4 - 36	2,65	MR CI 100 - FV0 90 LB	2,4 36,6
	76,5 - 38,2	26,4 - 36	2,65	MR CI 100 - FV0 100 LA	2,4 36,6
	84 - 42	23,5 - 32,1	1,9	MR ICI 80 - FV0 90 LB	2,4 33,3
	84 - 42	23,5 - 32,1	2,12	MR ICI 81 - FV0 90 LB	2,4 33,3
	86,2 - 43,1	23,4 - 31,9	1,32	MR CI 80 - FV0 90 LB	2,4 32,5
	86,2 - 43,1	23,4 - 31,9	1,6	MR CI 81 - FV0 90 LB	2,4 32,5
	86,2 - 43,1	23,4 - 31,9	1,32	MR CI 80 - FV0 100 LA	2,4 32,5
	89,2 - 44,6	22,1 - 30,2	> 3	MR ICI 100 - FV0 100 LA	2,4 31,4
	93 - 46,5	21,7 - 29,6	3	MR CI 100 - FV0 90 LB	2,4 30,1
	93 - 46,5	21,7 - 29,6	3	MR CI 100 - FV0 100 LA	2,4 30,1
	107 - 53,3	18,5 - 25,3	2,65	MR ICI 80 - FV0 90 LB	2,4 26,3
	108 - 53,8	18,7 - 25,5	2,24	MR CI 80 - FV0 90 LB	2,4 26
	108 - 53,8	18,7 - 25,5	2,5	MR CI 81 - FV0 90 LB	2,4 26
	108 - 53,8	18,7 - 25,5	2,24	MR CI 80 - FV0 100 LA	2,4 26
	113 - 56,6	17,5 - 23,8	> 3	MR ICI 100 - FV0 100 LA	2,4 24,7
	116 - 58,1	17,4 - 23,7	> 3	MR CI 100 - FV0 90 LB	2,4 24,1

1) Leistungen bei Dauerbetrieb S1; bei Betriebsarten S2 ... S10 können sie **gesteigert** werden (s. Kap. 2b);  $M_2$  steigt und  $f_s$  fällt proportional; bitte rückfragen.  
 2) Zur vollständigen Bestellbezeichnung s. Kap. 3. Auch **FO**-Ausführung «Normalbremsmotor» vorgesehen.  
 Bei der Bestimmung des Betriebsfaktors, **b** oder **c** als Belastung annehmen (Kap. 5).

1) Powers valid for continuous duty S1; **increase** possible for S2 ... S10 (see ch. 2b); in which case  $M_2$  increases and  $f_s$  decreases proportionately; consult us.  
 2) For complete designation when ordering see ch. 3. «Normal brake motor» design **FO** also possible.  
 When determining service factor, assume nature of load **b** or **c** (ch. 5).

15 - Herstellungsprogramm (Kegelstirnradgetriebemotoren für Fahrantriebe)  
 15 - Manufacturing programme (right angle shafts for traverse movements)  
 2.4 pol.

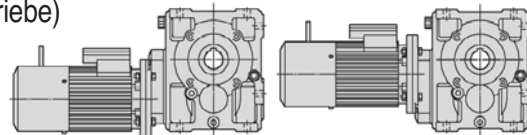

P <sub>1</sub> kW 1)	n <sub>2</sub> min <sup>-1</sup>	M <sub>2</sub> daN m	f <sub>s min</sub> bei / at n <sub>2</sub> min	Getriebe - Motor Gear reducer - Motor		i	
				2)			
2,2 1,5	116 - 58,1	17,4 - 23,7	> 3	MR CI 100 - FVO 100 LA	2,4	24,1	
	135 - 67,3	15 - 20,4	2,8	MR CI 80 - FVO 90 LB	2,4	20,8	
	135 - 67,3	15 - 20,4	2,8	MR CI 80 - FVO 100 LA	2,4	20,8	
	136 - 67,9	14,5 - 19,8	> 3	MR ICI 100 - FVO 100 LA	2,4	20,6	
	142 - 70,8	13,9 - 19	2,8	MR ICI 80 - FVO 90 LB	2,4	19,8	
	145 - 72,6	13,9 - 18,9	> 3	MR CI 100 - FVO 100 LA	2,4	19,3	
	168 - 84	12 - 16,4	> 3	MR CI 80 - FVO 90 LB	2,4	16,7	
	168 - 84	12 - 16,4	> 3	MR CI 80 - FVO 100 LA	2,4	16,7	
	213 - 107	9,5 - 12,9	> 3	MR CI 80 - FVO 90 LB	2,4	13,1	
	213 - 107	9,5 - 12,9	> 3	MR CI 80 - FVO 100 LA	2,4	13,1	
	283 - 142	7,1 - 9,7	> 3	MR CI 80 - FVO 90 LB	2,4	9,88	
	283 - 142	7,1 - 9,7	> 3	MR CI 80 - FVO 100 LA	2,4	9,88	
	3 2,2	22,1 - 11	119 - 175	1,5	MR C3I 125 - FVO 100 LB	2,4	127
		28 - 14	94 - 138	2	MR C3I 125 - FVO 100 LB	2,4	100
		28,7 - 14,3	94 - 138	1,6	MR ICI 125 - FVO 100 LB	2,4	97,7
		35,8 - 17,9	75 - 110	2,24	MR ICI 125 - FVO 100 LB	2,4	78,1
44,2 - 22,1		61 - 89	2,65	MR ICI 125 - FVO 100 LB	2,4	63,4	
55,2 - 27,6		48,8 - 72	> 3	MR ICI 125 - FVO 100 LB	2,4	50,7	

P <sub>1</sub> kW 1)	n <sub>2</sub> min <sup>-1</sup>	M <sub>2</sub> daN m	f <sub>s min</sub> bei / at n <sub>2</sub> min	Getriebe - Motor Gear reducer - Motor		i
				2)		
3 2,2	58,1 - 29,1	46,3 - 68	1,8	MR ICI 100 - FVO 100 LB	2,4	48,2
	69 - 34,5	39 - 57	> 3	MR ICI 125 - FVO 100 LB	2,4	40,6
	72,6 - 36,3	37,1 - 54	2,24	MR ICI 100 - FVO 100 LB	2,4	38,5
	76,5 - 38,2	36 - 53	1,9	MR CI 100 - FVO 100 LB	2,4	36,6
	89,2 - 44,6	30,2 - 44,3	3	MR ICI 100 - FVO 100 LB	2,4	31,4
	93 - 46,5	29,6 - 43,4	2,12	MR CI 100 - FVO 100 LB	2,4	30,1
	108 - 53,8	25,5 - 37,5	1,5	MR CI 80 - FVO 100 LB	2,4	26
	108 - 53,8	25,5 - 37,5	1,7	MR CI 81 - FVO 100 LB	2,4	26
	113 - 56,6	23,8 - 34,9	> 3	MR ICI 100 - FVO 100 LB	2,4	24,7
	116 - 58,1	23,7 - 34,7	> 3	MR CI 100 - FVO 100 LB	2,4	24,1
	135 - 67,3	20,4 - 30	1,9	MR CI 80 - FVO 100 LB	2,4	20,8
	135 - 67,3	20,4 - 30	2,24	MR CI 81 - FVO 100 LB	2,4	20,8
	136 - 67,9	19,8 - 29,1	> 3	MR ICI 100 - FVO 100 LB	2,4	20,6
	145 - 72,6	18,9 - 27,8	> 3	MR CI 100 - FVO 100 LB	2,4	19,3
	168 - 84	16,4 - 24	2,5	MR CI 80 - FVO 100 LB	2,4	16,7
	178 - 89,2	15,4 - 22,6	> 3	MR CI 100 - FVO 100 LB	2,4	15,7
	213 - 107	12,9 - 18,9	> 3	MR CI 80 - FVO 100 LB	2,4	13,1
	283 - 142	9,7 - 14,2	> 3	MR CI 80 - FVO 100 LB	2,4	9,88
	363 - 182	7,6 - 11,1	> 3	MR CI 80 - FVO 100 LB	2,4	7,71
	455 - 227	6 - 8,9	> 3	MR CI 80 - FVO 100 LB	2,4	6,16

2.6 pol.

P <sub>1</sub> kW 3)	n <sub>2</sub> min <sup>-1</sup>	M <sub>2</sub> daN m	f <sub>s min</sub> bei / at n <sub>2</sub> min	Getriebe - Motor Gear reducer - Motor		i	
				2)			
0,18 0,065	21,9 - 7,05	7,2 - 8,1	> 3	MR C3I 63 - FVO 71 A	2,6	128	
	22,6 - 7,25	7 - 7,9	2,12	MR C3I 50 - FVO 71 A	2,6	124	
	23,6 - 7,58	6,9 - 7,7	2,8	MR ICI 63 - FVO 71 A	2,6	119	
	4)	28,6 - 9,19	5,5 - 6,2	2,65	MR C3I 50 - FVO 71 A	2,6	97,9
		29,5 - 9,47	5,5 - 6,2	> 3	MR ICI 63 - FVO 71 A	2,6	95
		35,2 - 11,3	4,59 - 5,2	> 3	MR ICI 63 - FVO 71 A	2,6	79,5
		45,8 - 14,7	3,53 - 3,96	> 3	MR ICI 50 - FVO 71 A	2,6	61,1
		57,3 - 18,4	2,82 - 3,17	> 3	MR ICI 50 - FVO 71 A	2,6	48,9
		70,4 - 22,6	2,3 - 2,58	> 3	MR ICI 50 - FVO 71 A	2,6	39,8
		89,2 - 28,7	1,81 - 2,03	> 3	MR ICI 50 - FVO 71 A	2,6	31,4
		116 - 37,4	1,42 - 1,6	> 3	MR CI 50 - FVO 71 A	2,6	24,1
		145 - 46,7	1,14 - 1,28	> 3	MR CI 50 - FVO 71 A	2,6	19,3
178 - 57,4	0,92 - 1,04	> 3	MR CI 50 - FVO 71 A	2,6	15,7		
226 - 72,7	0,73 - 0,82	> 3	MR CI 50 - FVO 71 A	2,6	12,4		
272 - 87,4	0,61 - 0,68	> 3	MR CI 50 - FVO 71 A	2,6	10,3		
0,25 0,095	21,9 - 7,05	10 - 11,8	2,65	MR C3I 63 - FVO 71 B	2,6	128	
	22,6 - 7,25	9,7 - 11,5	1,4	MR C3I 50 - FVO 71 B	2,6	124	
	23,6 - 7,58	9,5 - 11,3	2	MR ICI 63 - FVO 71 B	2,6	119	
	4)	23,6 - 7,58	9,5 - 11,3	2,5	MR ICI 64 - FVO 71 B	2,6	119
		28,6 - 9,19	7,7 - 9,1	1,8	MR C3I 50 - FVO 71 B	2,6	97,9
		29,5 - 9,47	7,6 - 9	3	MR ICI 63 - FVO 71 B	2,6	95
		35,2 - 11,3	6,4 - 7,5	> 3	MR ICI 63 - FVO 71 B	2,6	79,5
		44 - 14,1	5,1 - 6	> 3	MR ICI 63 - FVO 71 B	2,6	63,6
		45,8 - 14,7	4,9 - 5,8	2,5	MR ICI 50 - FVO 71 B	2,6	61,1
		55 - 17,7	4,08 - 4,82	> 3	MR ICI 63 - FVO 71 B	2,6	50,9
		57,3 - 18,4	3,92 - 4,63	> 3	MR ICI 50 - FVO 71 B	2,6	48,9
		70,4 - 22,6	3,19 - 3,77	> 3	MR ICI 50 - FVO 71 B	2,6	39,8
		89,2 - 28,7	2,51 - 2,97	> 3	MR ICI 50 - FVO 71 B	2,6	31,4
		89,6 - 28,8	2,56 - 3,02	> 3	MR CI 63 - FVO 71 B	2,6	31,3
		116 - 37,4	1,97 - 2,33	> 3	MR CI 50 - FVO 71 B	2,6	24,1
		145 - 46,7	1,58 - 1,87	> 3	MR CI 50 - FVO 71 B	2,6	19,3
		178 - 57,4	1,28 - 1,52	> 3	MR CI 50 - FVO 71 B	2,6	15,7
		226 - 72,7	1,01 - 1,2	> 3	MR CI 50 - FVO 71 B	2,6	12,4
		272 - 87,4	0,84 - 1	> 3	MR CI 50 - FVO 71 B	2,6	10,3
0,37	20,8 - 6,69	15,6 - 18,4	> 3	MR C3I 80 - FVO 80 A	2,6	135	
0,14	21 - 6,76	15,4 - 18,2	> 3	MR C3I 80 - FVO 71 C	2,6	133	
	21,7 - 6,96	15 - 17,7	1,7	MR C3I 63 - FVO 80 A	2,6	129	

P <sub>1</sub> kW 3)	n <sub>2</sub> min <sup>-1</sup>	M <sub>2</sub> daN m	f <sub>s min</sub> bei / at n <sub>2</sub> min	Getriebe - Motor Gear reducer - Motor		i	
				2)			
0,37 0,14	21,7 - 6,96	15 - 17,7	1,9	MR C3I 64 - FVO 80 A	2,6	129	
	21,9 - 7,05	14,8 - 17,5	1,8	MR C3I 63 - FVO 71 C	2,6	128	
	21,9 - 7,05	14,8 - 17,5	2,24	MR C3I 64 - FVO 71 C	2,6	128	
	4)	23,6 - 7,58	14,1 - 16,6	1,32	MR ICI 63 - FVO 71 C	2,6	119
		23,6 - 7,58	14,1 - 16,6	1,7	MR ICI 64 - FVO 71 C	2,6	119
		27,5 - 8,83	11,8 - 13,9	2,24	MR C3I 63 - FVO 80 A	2,6	102
		27,5 - 8,83	11,8 - 13,9	2,8	MR C3I 64 - FVO 80 A	2,6	102
		29,5 - 9,47	11,3 - 13,3	2	MR ICI 63 - FVO 71 C	2,6	95
		29,5 - 9,47	11,3 - 13,3	2,5	MR ICI 64 - FVO 71 C	2,6	95
		33,9 - 10,9	9,8 - 11,5	> 3	MR ICI 80 - FVO 80 A	2,6	82,5
		34,4 - 11	9,5 - 11,1	1,4	MR C3I 50 - FVO 71 C	2,6	81,5
		35,2 - 11,3	9,4 - 11,1	2,5	MR ICI 63 - FVO 71 C	2,6	79,5
		35,3 - 11,3	9,4 - 11,1	2,12	MR ICI 63 - FVO 80 A	2,6	79,3
		35,3 - 11,3	9,4 - 11,1	2,5	MR ICI 64 - FVO 80 A	2,6	79,3
		44 - 14,1	7,5 - 8,9	3	MR ICI 63 - FVO 71 C	2,6	63,6
		44,1 - 14,2	7,5 - 8,9	3	MR ICI 63 - FVO 80 A	2,6	63,5
		45,8 - 14,7	7,2 - 8,5	1,7	MR ICI 50 - FVO 71 C	2,6	61,1
		55 - 17,7	6 - 7,1	> 3	MR ICI 63 - FVO 71 C	2,6	50,9
		55,2 - 17,7	6 - 7,1	> 3	MR ICI 63 - FVO 80 A	2,6	50,8
		57,2 - 18,4	5,8 - 6,8	2,12	MR ICI 50 - FVO 80 A	2,6	48,9
	57,3 - 18,4	5,8 - 6,8	2,12	MR ICI 50 - FVO 71 C	2,6	48,9	
	68,9 - 22,2	4,82 - 5,7	> 3	MR ICI 63 - FVO 80 A	2,6	40,6	
	70,4 - 22,6	4,72 - 5,6	3	MR ICI 50 - FVO 71 C	2,6	39,8	
	71,6 - 23	4,64 - 5,5	2,65	MR ICI 50 - FVO 80 A	2,6	39,1	
	87,9 - 28,2	3,78 - 4,45	> 3	MR ICI 50 - FVO 80 A	2,6	31,9	
	89,2 - 28,7	3,72 - 4,38	> 3	MR ICI 50 - FVO 71 C	2,6	31,4	
	89,6 - 28,8	3,79 - 4,46	> 3	MR CI 63 - FVO 71 C	2,6	31,3	
	89,6 - 28,8	3,79 - 4,46	> 3	MR CI 63 - FVO 80 A	2,6	31,3	
	111 - 35,8	2,98 - 3,51	> 3	MR ICI 50 - FVO 80 A	2,6	25,1	
	116 - 37,4	2,92 - 3,44	> 3	MR CI 50 - FVO 71 C	2,6	24,1	
116 - 37,4	2,92 - 3,44	> 3	MR CI 50 - FVO 80 A	2,6	24,1		
134 - 43	2,48 - 2,92	> 3	MR ICI 50 - FVO 80 A	2,6	20,9		
145 - 46,7	2,33 - 2,75	> 3	MR CI 50 - FVO 71 C	2,6	19,3		
145 - 46,7	2,33 - 2,75	> 3	MR CI 50 - FVO 80 A	2,6	19,3		
178 - 57,4	1,9 - 2,24	> 3	MR CI 50 - FVO 71 C	2,6	15,7		
178 - 57,4	1,9 - 2,24	> 3	MR CI 50 - FVO 80 A	2,6	15,7		
226 - 72,7	1,5 - 1,76	> 3	MR CI 50 - FVO 71 C	2,6	12,4		
226 - 72,7	1,5 - 1,76	> 3	MR CI 50 - FVO 80 A	2,6	12,4		

1) Leistungen bei Dauerbetrieb S1; bei Betriebsarten S2 ... S10 können sie gesteigert werden (s. Kap. 2b); M<sub>2</sub> steigt und f<sub>s</sub> fällt proportional; bitte rückfragen.  
 2) Zur vollständigen Bestellbezeichnung s. Kap. 3. Auch FO-Ausführung «Normalbremsmotor» vorgesehen.  
 3) Leistungen bei Dauerbetrieb S1; bei Betriebsarten S3 60 und 40% können die Leistungen bis 18% gesteigert werden; M<sub>2</sub> steigt und f<sub>s</sub> fällt proportional; bitte rückfragen.  
 4) Auch Getriebegröße 40 zur Verfügung; bitte rückfragen.  
 Bei der Bestimmung des Betriebsfaktors, **b** oder **c** als Belastung annehmen (Kap. 5).

1) Powers valid for continuous duty; increase possible for S2 ... S10 (see ch. 2b); in which case M<sub>2</sub> increases and f<sub>s</sub> decreases proportionately; consult us.  
 2) For complete designation when ordering see ch. 3. «Normal brake motor» design FO also possible.  
 3) Powers valid for continuous duty S1; 18% increase possible for S3 duty 60 and 40% in which case M<sub>2</sub> increases and f<sub>s</sub> decreases proportionately; consult us.  
 4) Gear reducer size 40 also available; consult us.  
 When determining service factor, assume nature of load **b** or **c** (ch. 5).



15 - Herstellungsprogramm (Kegelstirradgetriebemotoren für Fahrtriebe)  
 15 - Manufacturing programme (right angle shafts for traverse movements)  
 2.6 pol.

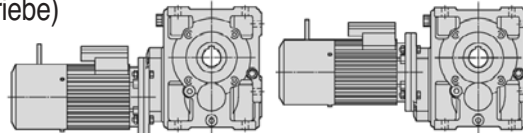

P <sub>1</sub> kW	n <sub>2</sub> min <sup>-1</sup>	M <sub>2</sub> daN m	f <sub>s</sub> <sub>min</sub> bei / at n <sub>2</sub> min	Getriebe - Motor Gear reducer - Motor	i	
3)				2)		
<b>0,37</b> <b>0,14</b> 4)	<b>272 - 87,4</b>	1,25 - 1,47	> 3	<b>MR CI 50 - FV0 71 C</b>	<b>2.6</b> 10,3	
	<b>272 - 87,4</b>	1,25 - 1,47	> 3	<b>MR CI 50 - FV0 80 A</b>	<b>2.6</b> 10,3	
<b>0,55</b> <b>0,21</b>	<b>20,8 - 6,69</b>	23,2 - 27,6	2,24	<b>MR C3I 80 - FV0 80 B</b>	<b>2.6</b> 135	
	<b>20,8 - 6,69</b>	23,2 - 27,6	2,65	<b>MR C3I 81 - FV0 80 B</b>	<b>2.6</b> 135	
	<b>21,7 - 6,96</b>	22,3 - 26,5	1,32	<b>MR C3I 64 - FV0 80 B</b>	<b>2.6</b> 129	
	<b>26,4 - 8,48</b>	18,3 - 21,8	> 3	<b>MR C3I 80 - FV0 80 B</b>	<b>2.6</b> 106	
	<b>27,5 - 8,83</b>	17,6 - 20,9	1,5	<b>MR C3I 63 - FV0 80 B</b>	<b>2.6</b> 102	
	<b>27,5 - 8,83</b>	17,6 - 20,9	1,9	<b>MR C3I 64 - FV0 80 B</b>	<b>2.6</b> 102	
	<b>33,9 - 10,9</b>	14,5 - 17,3	3	<b>MR ICI 80 - FV0 80 B</b>	<b>2.6</b> 82,5	
	<b>35,3 - 11,3</b>	14 - 16,6	1,4	<b>MR ICI 63 - FV0 80 B</b>	<b>2.6</b> 79,3	
	<b>35,3 - 11,3</b>	14 - 16,6	1,7	<b>MR ICI 64 - FV0 80 B</b>	<b>2.6</b> 79,3	
	<b>42,4 - 13,6</b>	11,6 - 13,8	> 3	<b>MR ICI 80 - FV0 80 B</b>	<b>2.6</b> 66	
	<b>44,1 - 14,2</b>	11,2 - 13,3	2	<b>MR ICI 63 - FV0 80 B</b>	<b>2.6</b> 63,5	
	<b>44,1 - 14,2</b>	11,2 - 13,3	2,5	<b>MR ICI 64 - FV0 80 B</b>	<b>2.6</b> 63,5	
	<b>55,2 - 17,7</b>	9 - 10,6	2,5	<b>MR ICI 63 - FV0 80 B</b>	<b>2.6</b> 50,8	
	<b>57,2 - 18,4</b>	8,6 - 10,2	1,4	<b>MR ICI 50 - FV0 80 B</b>	<b>2.6</b> 48,9	
	<b>68,9 - 22,2</b>	7,2 - 8,5	> 3	<b>MR ICI 63 - FV0 80 B</b>	<b>2.6</b> 40,6	
	<b>71,6 - 23</b>	6,9 - 8,2	1,8	<b>MR ICI 50 - FV0 80 B</b>	<b>2.6</b> 39,1	
	<b>87,4 - 28,1</b>	5,6 - 6,7	> 3	<b>MR ICI 63 - FV0 80 B</b>	<b>2.6</b> 32	
	<b>87,9 - 28,2</b>	5,6 - 6,7	2,5	<b>MR ICI 50 - FV0 80 B</b>	<b>2.6</b> 31,9	
	<b>89,6 - 28,8</b>	5,6 - 6,7	> 3	<b>MR CI 63 - FV0 80 B</b>	<b>2.6</b> 31,3	
	<b>111 - 35,8</b>	4,43 - 5,3	> 3	<b>MR ICI 50 - FV0 80 B</b>	<b>2.6</b> 25,1	
	<b>116 - 37,4</b>	4,34 - 5,2	2,65	<b>MR CI 50 - FV0 80 B</b>	<b>2.6</b> 24,1	
	<b>134 - 43</b>	3,69 - 4,38	> 3	<b>MR ICI 50 - FV0 80 B</b>	<b>2.6</b> 20,9	
	<b>145 - 46,7</b>	3,47 - 4,12	> 3	<b>MR CI 50 - FV0 80 B</b>	<b>2.6</b> 19,3	
	<b>178 - 57,4</b>	2,83 - 3,36	> 3	<b>MR CI 50 - FV0 80 B</b>	<b>2.6</b> 15,7	
	<b>226 - 72,7</b>	2,23 - 2,65	> 3	<b>MR CI 50 - FV0 80 B</b>	<b>2.6</b> 12,4	
	<b>272 - 87,4</b>	1,86 - 2,2	> 3	<b>MR CI 50 - FV0 80 B</b>	<b>2.6</b> 10,3	
	<b>0,75</b> <b>0,3</b>	<b>20,8 - 6,69</b>	31,7 - 39,4	1,6	<b>MR C3I 80 - FV0 80 C</b>	<b>2.6</b> 135
		<b>20,8 - 6,69</b>	31,7 - 39,4	1,8	<b>MR C3I 81 - FV0 80 C</b>	<b>2.6</b> 135
		<b>22,1 - 7,1</b>	29,8 - 37,1	> 3	<b>MR C3I 100 - FV0 90 S</b>	<b>2.6</b> 127
		<b>22,4 - 7,18</b>	29,5 - 36,7	> 3	<b>MR C3I 100 - FV0 80 C</b>	<b>2.6</b> 125
		<b>26,4 - 8,48</b>	25 - 31,1	2,12	<b>MR C3I 80 - FV0 80 C</b>	<b>2.6</b> 106
		<b>26,4 - 8,48</b>	25 - 31,1	2,5	<b>MR C3I 81 - FV0 80 C</b>	<b>2.6</b> 106
		<b>27,5 - 8,83</b>	24 - 29,8	1,32	<b>MR C3I 64 - FV0 80 C</b>	<b>2.6</b> 102
		<b>30,1 - 9,69</b>	22,3 - 27,8	> 3	<b>MR ICI 100 - FV0 90 S</b>	<b>2.6</b> 92,9
		<b>33,9 - 10,9</b>	19,8 - 24,7	2,12	<b>MR ICI 80 - FV0 80 C</b>	<b>2.6</b> 82,5
		<b>33,9 - 10,9</b>	19,8 - 24,7	2,24	<b>MR ICI 81 - FV0 80 C</b>	<b>2.6</b> 82,5
		<b>36,6 - 11,8</b>	18,4 - 22,9	> 3	<b>MR ICI 100 - FV0 90 S</b>	<b>2.6</b> 76,4
		<b>42,4 - 13,6</b>	15,9 - 19,7	3	<b>MR ICI 80 - FV0 80 C</b>	<b>2.6</b> 66
		<b>43,1 - 13,8</b>	15,6 - 19,5	2,65	<b>MR ICI 80 - FV0 90 S</b>	<b>2.6</b> 65
		<b>44,1 - 14,2</b>	15,3 - 19	1,4	<b>MR ICI 63 - FV0 80 C</b>	<b>2.6</b> 63,5
		<b>44,1 - 14,2</b>	15,3 - 19	1,8	<b>MR ICI 64 - FV0 80 C</b>	<b>2.6</b> 63,5
		<b>44,8 - 14,4</b>	15 - 18,7	1,25	<b>MR ICI 63 - FV0 90 S</b>	<b>2.6</b> 62,5
		<b>44,8 - 14,4</b>	15 - 18,7	1,5	<b>MR ICI 64 - FV0 90 S</b>	<b>2.6</b> 62,5
		<b>53 - 17</b>	12,7 - 15,8	> 3	<b>MR ICI 80 - FV0 80 C</b>	<b>2.6</b> 52,8
		<b>53,8 - 17,3</b>	12,5 - 15,6	> 3	<b>MR ICI 80 - FV0 90 S</b>	<b>2.6</b> 52
<b>55,2 - 17,7</b>		12,2 - 15,2	1,8	<b>MR ICI 63 - FV0 80 C</b>	<b>2.6</b> 50,8	
<b>55,2 - 17,7</b>		12,2 - 15,2	2,24	<b>MR ICI 64 - FV0 80 C</b>	<b>2.6</b> 50,8	
<b>56 - 18</b>		12 - 15	1,8	<b>MR ICI 63 - FV0 90 S</b>	<b>2.6</b> 50	
<b>56 - 18</b>		12 - 15	2,24	<b>MR ICI 64 - FV0 90 S</b>	<b>2.6</b> 50	
<b>67,3 - 21,6</b>		10 - 12,4	> 3	<b>MR ICI 80 - FV0 90 S</b>	<b>2.6</b> 41,6	
<b>68,9 - 22,2</b>		9,8 - 12,2	2,36	<b>MR ICI 63 - FV0 80 C</b>	<b>2.6</b> 40,6	
<b>68,9 - 22,2</b>		9,8 - 12,2	2,8	<b>MR ICI 64 - FV0 80 C</b>	<b>2.6</b> 40,6	
<b>70 - 22,5</b>		9,6 - 12	2,24	<b>MR ICI 63 - FV0 90 S</b>	<b>2.6</b> 40	
<b>70 - 22,5</b>		9,6 - 12	2,8	<b>MR ICI 64 - FV0 90 S</b>	<b>2.6</b> 40	
<b>86,2 - 27,7</b>		8 - 9,9	> 3	<b>MR CI 80 - FV0 90 S</b>	<b>2.6</b> 32,5	
<b>87,4 - 28,1</b>		7,7 - 9,6	> 3	<b>MR ICI 63 - FV0 80 C</b>	<b>2.6</b> 32	
<b>87,5 - 28,1</b>		7,7 - 9,6	3	<b>MR ICI 63 - FV0 90 S</b>	<b>2.6</b> 32	
<b>89,6 - 28,8</b>		7,7 - 9,6	2,24	<b>MR CI 63 - FV0 80 C</b>	<b>2.6</b> 31,3	
<b>89,6 - 28,8</b>		7,7 - 9,6	2,65	<b>MR CI 64 - FV0 80 C</b>	<b>2.6</b> 31,3	
<b>89,6 - 28,8</b>		7,7 - 9,6	2,24	<b>MR CI 63 - FV0 90 S</b>	<b>2.6</b> 31,3	
<b>89,6 - 28,8</b>		7,7 - 9,6	2,65	<b>MR CI 64 - FV0 90 S</b>	<b>2.6</b> 31,3	
<b>111 - 35,7</b>		6,1 - 7,5	> 3	<b>MR ICI 63 - FV0 90 S</b>	<b>2.6</b> 25,2	
<b>112 - 36</b>		6,1 - 7,6	> 3	<b>MR CI 63 - FV0 80 C</b>	<b>2.6</b> 25	
<b>112 - 36</b>		6,1 - 7,6	> 3	<b>MR CI 63 - FV0 90 S</b>	<b>2.6</b> 25	

P <sub>1</sub> kW	n <sub>2</sub> min <sup>-1</sup>	M <sub>2</sub> daN m	f <sub>s</sub> <sub>min</sub> bei / at n <sub>2</sub> min	Getriebe - Motor Gear reducer - Motor	i	
3)				2)		
<b>0,75</b> <b>0,3</b>	<b>116 - 37,4</b>	5,9 - 7,4	1,9	<b>MR CI 50 - FV0 80 C</b>	<b>2.6</b> 24,1	
	<b>135 - 43,4</b>	4,98 - 6,2	> 3	<b>MR ICI 63 - FV0 90 S</b>	<b>2.6</b> 20,7	
	<b>140 - 45</b>	4,91 - 6,1	> 3	<b>MR CI 63 - FV0 80 C</b>	<b>2.6</b> 20	
	<b>140 - 45</b>	4,91 - 6,1	> 3	<b>MR CI 63 - FV0 90 S</b>	<b>2.6</b> 20	
	<b>145 - 46,7</b>	4,73 - 5,9	2,5	<b>MR CI 50 - FV0 80 C</b>	<b>2.6</b> 19,3	
	<b>175 - 56,3</b>	3,93 - 4,89	> 3	<b>MR CI 63 - FV0 90 S</b>	<b>2.6</b> 16	
	<b>178 - 57,4</b>	3,85 - 4,8	3	<b>MR CI 50 - FV0 80 C</b>	<b>2.6</b> 15,7	
	<b>222 - 71,3</b>	3,1 - 3,86	> 3	<b>MR CI 63 - FV0 90 S</b>	<b>2.6</b> 12,6	
	<b>226 - 72,7</b>	3,04 - 3,78	> 3	<b>MR CI 50 - FV0 80 C</b>	<b>2.6</b> 12,4	
	<b>270 - 86,9</b>	2,54 - 3,17	> 3	<b>MR CI 63 - FV0 90 S</b>	<b>2.6</b> 10,4	
	<b>272 - 87,4</b>	2,53 - 3,15	> 3	<b>MR CI 50 - FV0 80 C</b>	<b>2.6</b> 10,3	
	<b>1,1</b> <b>0,42</b>	<b>22,1 - 7,1</b>	43,7 - 52	2,5	<b>MR C3I 100 - FV0 90 LA</b>	<b>2.6</b> 127
		<b>30,1 - 9,69</b>	32,8 - 38,9	2,8	<b>MR ICI 100 - FV0 90 LA</b>	<b>2.6</b> 92,9
		<b>36,6 - 11,8</b>	27 - 32	3	<b>MR ICI 100 - FV0 90 LA</b>	<b>2.6</b> 76,4
		<b>43,1 - 13,8</b>	22,9 - 27,2	1,9	<b>MR ICI 80 - FV0 90 LA</b>	<b>2.6</b> 65
		<b>43,1 - 13,8</b>	22,9 - 27,2	2	<b>MR ICI 81 - FV0 90 LA</b>	<b>2.6</b> 65
		<b>45,8 - 14,7</b>	21,6 - 25,6	> 3	<b>MR ICI 100 - FV0 90 LA</b>	<b>2.6</b> 61,2
		<b>53,8 - 17,3</b>	18,3 - 21,8	2,65	<b>MR ICI 80 - FV0 90 LA</b>	<b>2.6</b> 52
		<b>56 - 18</b>	17,6 - 20,9	1,32	<b>MR ICI 63 - FV0 90 LA</b>	<b>2.6</b> 50
<b>56 - 18</b>		17,6 - 20,9	1,6	<b>MR ICI 64 - FV0 90 LA</b>	<b>2.6</b> 50	
<b>67,3 - 21,6</b>		14,7 - 17,4	> 3	<b>MR ICI 80 - FV0 90 LA</b>	<b>2.6</b> 41,6	
<b>70 - 22,5</b>		14,1 - 16,8	1,6	<b>MR ICI 63 - FV0 90 LA</b>	<b>2.6</b> 40	
<b>70 - 22,5</b>		14,1 - 16,8	2	<b>MR ICI 64 - FV0 90 LA</b>	<b>2.6</b> 40	
<b>84 - 27</b>		11,8 - 14	> 3	<b>MR ICI 80 - FV0 90 LA</b>	<b>2.6</b> 33,3	
<b>86,2 - 27,7</b>		11,7 - 13,9	> 3	<b>MR CI 80 - FV0 90 LA</b>	<b>2.6</b> 32,5	
<b>87,5 - 28,1</b>		11,3 - 13,4	2,12	<b>MR ICI 63 - FV0 90 LA</b>	<b>2.6</b> 32	
<b>87,5 - 28,1</b>		11,3 - 13,4	2,5	<b>MR ICI 64 - FV0 90 LA</b>	<b>2.6</b> 32	
<b>89,6 - 28,8</b>		11,3 - 13,4	1,6	<b>MR ICI 63 - FV0 90 LA</b>	<b>2.6</b> 31,3	
<b>89,6 - 28,8</b>		11,3 - 13,4	1,9	<b>MR CI 64 - FV0 90 LA</b>	<b>2.6</b> 31,3	
<b>108 - 34,6</b>		9,4 - 11,1	> 3	<b>MR CI 80 - FV0 90 LA</b>	<b>2.6</b> 26	
<b>111 - 35,7</b>		8,9 - 10,6	3	<b>MR ICI 63 - FV0 90 LA</b>	<b>2.6</b> 25,2	
<b>112 - 36</b>		9 - 10,7	2,5	<b>MR CI 63 - FV0 90 LA</b>	<b>2.6</b> 25	
<b>112 - 36</b>		9 - 10,7	3	<b>MR CI 64 - FV0 90 LA</b>	<b>2.6</b> 25	
<b>135 - 43,4</b>		7,3 - 8,7	> 3	<b>MR ICI 63 - FV0 90 LA</b>	<b>2.6</b> 20,7	
<b>140 - 45</b>		7,2 - 8,6	> 3	<b>MR CI 63 - FV0 90 LA</b>	<b>2.6</b> 20	
<b>175 - 56,3</b>		5,8 - 6,8	> 3	<b>MR CI 63 - FV0 90 LA</b>	<b>2.6</b> 16	
<b>222 - 71,3</b>		4,54 - 5,4	> 3	<b>MR CI 63 - FV0 90 LA</b>	<b>2.6</b> 12,6	
<b>270 - 86,9</b>		3,73 - 4,43	> 3	<b>MR CI 63 - FV0 90 LA</b>	<b>2.6</b> 10,4	
<b>351 - 113</b>		2,87 - 3,41	> 3	<b>MR CI 63 - FV0 90 LA</b>	<b>2.6</b> 7,98	
<b>444 - 143</b>		2,27 - 2,7	> 3	<b>MR CI 63 - FV0 90 LA</b>	<b>2.6</b> 6,31	
<b>1,5</b> <b>0,55</b>		<b>22,1 - 7,1</b>	60 - 68	> 3	<b>MR C3I 125 - FV0 100 LA</b>	<b>2.6</b> 127
		<b>22,1 - 7,1</b>	60 - 68	1,9	<b>MR C3I 100 - FV0 90 LB</b>	<b>2.6</b> 127
		<b>22,7 - 7,31</b>	58 - 66	> 3	<b>MR C3I 125 - FV0 90 LB</b>	<b>2.6</b> 123
		<b>28 - 9,01</b>	47 - 54	2,65	<b>MR C3I 100 - FV0 90 LB</b>	<b>2.6</b> 99,9
		<b>28,7 - 9,22</b>	47 - 54	> 3	<b>MR ICI 125 - FV0 100 LA</b>	<b>2.6</b> 97,7
		<b>30,1 - 9,69</b>	44,7 - 51	2,12	<b>MR ICI 100 - FV0 90 LB</b>	<b>2.6</b> 92,9
		<b>36,6 - 11,8</b>	36,8 - 41,9	2,24	<b>MR ICI 100 - FV0 90 LB</b>	<b>2.6</b> 76,4
		<b>38,2 - 12,3</b>	35,2 - 40,2	2,65	<b>MR ICI 100 - FV0 100 LA</b>	<b>2.6</b> 73,2
		<b>43,1 - 13,8</b>	31,3 - 35,7	1,4	<b>MR ICI 80 - FV0 90 LB</b>	<b>2.6</b> 65
	<b>43,1 - 13,8</b>	31,3 - 35,7	1,5	<b>MR ICI 81 - FV0 90 LB</b>	<b>2.6</b> 65	
	<b>45,8 - 14,7</b>	29,4 - 33,5	> 3	<b>MR ICI 100 - FV0 90 LB</b>	<b>2.6</b> 61,2	
	<b>46,5 - 14,9</b>	29 - 33	2,8	<b>MR ICI 100 - FV0 100 LA</b>	<b>2.6</b> 60,2	
	<b>53,8 - 17,3</b>	25 - 28,5	2	<b>MR ICI 80 - FV0 90 LB</b>	<b>2.6</b> 52	
	<b>53,8 - 17,3</b>	25 - 28,5	2,36	<b>MR ICI 81 - FV0 90 LB</b>	<b>2.6</b> 52	
	<b>57,2 - 18,4</b>	23,5 - 26,8	> 3	<b>MR ICI 100 - FV0 90 LB</b>	<b>2.6</b> 48,9	
	<b>58,1 - 18,7</b>	23,2 - 26,4	> 3	<b>MR ICI 100 - FV0 100 LA</b>	<b>2.6</b> 48,2	
	<b>67,3 - 21,6</b>	20 - 22,8	2,5	<b>MR CI 80 - FV0 90 LB</b>	<b>2.6</b> 41,6	
	<b>72,6 - 23,3</b>	18,5 - 21,1	> 3	<b>MR ICI 100 - FV0 100 LA</b>	<b>2.6</b> 38,5	
	<b>76,5 - 24,6</b>	18 - 20,5	> 3	<b>MR CI 100 - FV0 90 LB</b>	<b>2.6</b> 36,6	
	<b>76</b>					

## 15 - Herstellungsprogramm (Kegelstirnradtriebemotoren für Fahrtriebe)

## 15 - Manufacturing programme (right angle shafts for traverse movements)

2.6 pol.

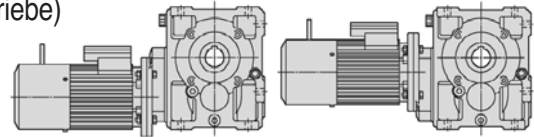

$P_1$ kW	$n_2$ $\text{min}^{-1}$	$M_2$ daN m	$f_{s \text{ min}}$ bei / at $n_2 \text{ min}$	Getriebe - Motor Gear reducer - Motor	$i$
3)				2)	
1,5 - 0,55	89,6 - 28,8	15,3 - 17,5	1,4	MR CI 64 - FVO 90 LB 2.6	31,3
	93 - 29,9	14,8 - 16,9	>3	MR CI 100 - FVO 90 LB 2.6	30,1
	93 - 29,9	14,8 - 16,9	>3	MR CI 100 - FVO 100 LA 2.6	30,1
	107 - 34,2	12,6 - 14,4	>3	MR ICI 80 - FVO 90 LB 2.6	26,3
	108 - 34,6	12,8 - 14,6	>3	MR CI 80 - FVO 90 LB 2.6	26
	108 - 34,6	12,8 - 14,6	>3	MR CI 80 - FVO 100 LA 2.6	26
	112 - 36	12,3 - 14	1,9	MR CI 63 - FVO 90 LB 2.6	25
	112 - 36	12,3 - 14	2,36	MR CI 64 - FVO 90 LB 2.6	25
	113 - 36,4	11,9 - 13,6	>3	MR ICI 100 - FVO 100 LA 2.6	24,7
	135 - 43,3	10,2 - 11,7	>3	MR CI 80 - FVO 100 LA 2.6	20,8
	136 - 43,7	9,9 - 11,3	>3	MR ICI 100 - FVO 100 LA 2.6	20,6
	140 - 45	9,8 - 11,2	2,36	MR CI 63 - FVO 90 LB 2.6	20
	140 - 45	9,8 - 11,2	3	MR CI 64 - FVO 90 LB 2.6	20
	142 - 45,5	9,5 - 10,8	>3	MR ICI 80 - FVO 90 LB 2.6	19,8
	168 - 54	8,2 - 9,3	>3	MR CI 80 - FVO 100 LA 2.6	16,7
	175 - 56,3	7,9 - 9	2,8	MR CI 63 - FVO 90 LB 2.6	16
	213 - 68,5	6,5 - 7,4	>3	MR CI 80 - FVO 100 LA 2.6	13,1
	222 - 71,3	6,2 - 7,1	>3	MR CI 63 - FVO 90 LB 2.6	12,6
	270 - 86,9	5,1 - 5,8	>3	MR CI 63 - FVO 90 LB 2.6	10,4
	283 - 91,1	4,85 - 5,5	>3	MR CI 80 - FVO 100 LA 2.6	9,88
351 - 113	3,92 - 4,47	>3	MR CI 63 - FVO 90 LB 2.6	7,98	
444 - 143	3,1 - 3,53	>3	MR CI 63 - FVO 90 LB 2.6	6,31	
1,85 - 0,75	22,1 - 7,1	74 - 93	3	MR C3I 125 - FVO 100 LB 2.6	127
	28,7 - 9,22	58 - 73	3	MR ICI 125 - FVO 100 LB 2.6	97,7
	35,8 - 11,5	46,3 - 58	>3	MR ICI 125 - FVO 100 LB 2.6	78,1
	38,2 - 12,3	43,4 - 55	2	MR ICI 100 - FVO 100 LB 2.6	73,2
	44,2 - 14,2	37,6 - 47,4	>3	MR ICI 125 - FVO 100 LB 2.6	63,4
	46,5 - 14,9	35,7 - 45,1	2,12	MR ICI 100 - FVO 100 LB 2.6	60,2
	58,1 - 18,7	28,6 - 36	>3	MR ICI 100 - FVO 100 LB 2.6	48,2
	72,6 - 23,3	22,9 - 28,8	>3	MR ICI 100 - FVO 100 LB 2.6	38,5
	76,5 - 24,6	22,2 - 28	>3	MR CI 100 - FVO 100 LB 2.6	36,6
	86,2 - 27,7	19,7 - 24,8	1,8	MR CI 80 - FVO 100 LB 2.6	32,5
	86,2 - 27,7	19,7 - 24,8	2,12	MR CI 81 - FVO 100 LB 2.6	32,5
	89,2 - 28,7	18,6 - 23,5	>3	MR ICI 100 - FVO 100 LB 2.6	31,4
	93 - 29,9	18,2 - 23	>3	MR CI 100 - FVO 100 LB 2.6	30,1
	108 - 34,6	15,7 - 19,9	3	MR CI 80 - FVO 100 LB 2.6	26
	113 - 36,4	14,7 - 18,5	>3	MR ICI 100 - FVO 100 LB 2.6	24,7
	116 - 37,4	14,6 - 18,4	>3	MR CI 100 - FVO 100 LB 2.6	24,1
	135 - 43,3	12,6 - 15,9	>3	MR CI 80 - FVO 100 LB 2.6	20,8
	136 - 43,7	12,2 - 15,4	>3	MR ICI 100 - FVO 100 LB 2.6	20,6
	168 - 54	10,1 - 12,7	>3	MR CI 80 - FVO 100 LB 2.6	16,7
	213 - 68,5	8 - 10	>3	MR CI 80 - FVO 100 LB 2.6	13,1
283 - 91,1	6 - 7,5	>3	MR CI 80 - FVO 100 LB 2.6	9,88	
2,2 0,9	22,1 - 7,1	88 - 111	2,36	MR C3I 125 - FVO 112 MA 2.6	127
	28 - 9	69 - 88	>3	MR C3I 125 - FVO 112 MA 2.6	100
	28,7 - 9,22	69 - 88	2,5	MR ICI 125 - FVO 112 MA 2.6	97,7

$P_1$ kW	$n_2$ $\text{min}^{-1}$	$M_2$ daN m	$f_{s \text{ min}}$ bei / at $n_2 \text{ min}$	Getriebe - Motor Gear reducer - Motor	$i$
3)				2)	
2,2 0,9	35,8 - 11,5	55 - 70	>3	MR ICI 125 - FVO 112 MA 2.6	78,1
	38,2 - 12,3	52 - 66	1,7	MR ICI 100 - FVO 112 MA 2.6	73,2
	44,2 - 14,2	44,7 - 57	>3	MR ICI 125 - FVO 112 MA 2.6	63,4
	46,5 - 14,9	42,5 - 54	1,7	MR ICI 100 - FVO 112 MA 2.6	60,2
	58,1 - 18,7	34 - 43,3	2,8	MR ICI 100 - FVO 112 MA 2.6	48,2
	72,6 - 23,3	27,2 - 34,6	>3	MR ICI 100 - FVO 112 MA 2.6	38,5
	76,5 - 24,6	26,4 - 33,6	3	MR CI 100 - FVO 112 MA 2.6	36,6
	86,2 - 27,7	23,4 - 29,8	1,5	MR CI 80 - FVO 112 MA 2.6	32,5
	86,2 - 27,7	23,4 - 29,8	1,8	MR CI 81 - FVO 112 MA 2.6	32,5
	89,2 - 28,7	22,1 - 28,2	>3	MR ICI 100 - FVO 112 MA 2.6	31,4
	93 - 29,9	21,7 - 27,6	>3	MR CI 100 - FVO 112 MA 2.6	30,1
	108 - 34,6	18,7 - 23,8	2,5	MR CI 80 - FVO 112 MA 2.6	26
	108 - 34,6	18,7 - 23,8	2,8	MR CI 81 - FVO 112 MA 2.6	26
	113 - 36,4	17,5 - 22,2	>3	MR ICI 100 - FVO 112 MA 2.6	24,7
	116 - 37,4	17,4 - 22,1	>3	MR CI 100 - FVO 112 MA 2.6	24,1
	135 - 43,3	15 - 19,1	3	MR CI 80 - FVO 112 MA 2.6	20,8
	136 - 43,7	14,5 - 18,5	>3	MR ICI 100 - FVO 112 MA 2.6	20,6
	168 - 54	12 - 15,3	>3	MR CI 80 - FVO 112 MA 2.6	16,7
	213 - 68,5	9,5 - 12	>3	MR CI 80 - FVO 112 MA 2.6	13,1
	283 - 91,1	7,1 - 9,1	>3	MR CI 80 - FVO 112 MA 2.6	9,88
3 1,1	22,1 - 7,1	119 - 136	2	MR C3I 125 - FVO 112 MB 2.6	127
	28 - 9	94 - 107	2,65	MR C3I 125 - FVO 112 MB 2.6	100
	28,7 - 9,22	94 - 107	2	MR ICI 125 - FVO 112 MB 2.6	97,7
	35,8 - 11,5	75 - 86	2,8	MR ICI 125 - FVO 112 MB 2.6	78,1
	38,2 - 12,3	70 - 80	1,32	MR ICI 100 - FVO 112 MB 2.6	73,2
	44,2 - 14,2	61 - 70	>3	MR ICI 125 - FVO 112 MB 2.6	63,4
	46,5 - 14,9	58 - 66	1,4	MR ICI 100 - FVO 112 MB 2.6	60,2
	55,2 - 17,7	48,8 - 56	>3	MR ICI 125 - FVO 112 MB 2.6	50,7
	58,1 - 18,7	46,3 - 53	2,36	MR ICI 100 - FVO 112 MB 2.6	48,2
	72,6 - 23,3	37,1 - 42,3	2,8	MR ICI 100 - FVO 112 MB 2.6	38,5
	76,5 - 24,6	36 - 41	2,36	MR CI 100 - FVO 112 MB 2.6	36,6
	86,2 - 27,7	31,9 - 36,4	1,5	MR CI 81 - FVO 112 MB 2.6	32,5
	89,2 - 28,7	30,2 - 34,4	>3	MR ICI 100 - FVO 112 MB 2.6	31,4
	93 - 29,9	29,6 - 33,7	2,65	MR CI 100 - FVO 112 MB 2.6	30,1
	108 - 34,6	25,5 - 29,1	2	MR CI 80 - FVO 112 MB 2.6	26
	108 - 34,6	25,5 - 29,1	2,24	MR CI 81 - FVO 112 MB 2.6	26
	113 - 36,4	23,8 - 27,2	>3	MR ICI 100 - FVO 112 MB 2.6	24,7
	116 - 37,4	23,7 - 27	>3	MR CI 100 - FVO 112 MB 2.6	24,1
	135 - 43,3	20,4 - 23,3	2,5	MR CI 80 - FVO 112 MB 2.6	20,8
	136 - 43,7	19,8 - 22,6	>3	MR ICI 100 - FVO 112 MB 2.6	20,6
145 - 46,7	18,9 - 21,6	>3	MR CI 100 - FVO 112 MB 2.6	19,3	
168 - 54	16,4 - 18,7	>3	MR CI 80 - FVO 112 MB 2.6	16,7	
213 - 68,5	12,9 - 14,7	>3	MR CI 80 - FVO 112 MB 2.6	13,1	
283 - 91,1	9,7 - 11,1	>3	MR CI 80 - FVO 112 MB 2.6	9,88	
363 - 117	7,6 - 8,6	>3	MR CI 80 - FVO 112 MB 2.6	7,71	
455 - 146	6 - 6,9	>3	MR CI 80 - FVO 112 MB 2.6	6,16	

2.8 pol.

$P_1$ kW	$n_2$ $\text{min}^{-1}$	$M_2$ daN m	$f_{s \text{ min}}$ bei / at $n_2 \text{ min}$	Getriebe - Motor Gear reducer - Motor	$i$
3)				2)	
0,18 0,045	20,7 - 5,25	7,6 - 7,5	2,12	MRC3I 50 - FVO 63 C 2.8	135
	21,9 - 5,56	7,2 - 7,1	>3	MRC3I 63 - FVO 71 A 2.8	128
	22,6 - 5,72	7 - 6,9	2,36	MRC3I 50 - FVO 71 A 2.8	124
4)	23,6 - 5,98	6,9 - 6,8	>3	MR ICI 63 - FVO 71 A 2.8	119
	28,6 - 7,25	5,5 - 5,5	3	MRC3I 50 - FVO 71 A 2.8	97,9
	29,5 - 7,47	5,5 - 5,4	>3	MR ICI 63 - FVO 71 A 2.8	95
	33,2 - 8,42	4,87 - 4,8	3	MR ICI 50 - FVO 63 C 2.8	84,3
	41,5 - 10,5	3,89 - 3,84	>3	MR ICI 50 - FVO 63 C 2.8	67,5
	45,8 - 11,6	3,53 - 3,48	>3	MR ICI 50 - FVO 71 A 2.8	61,1
	51 - 12,9	3,17 - 3,12	>3	MR ICI 50 - FVO 63 C 2.8	54,9
	57,3 - 14,5	2,82 - 2,78	>3	MR ICI 50 - FVO 71 A 2.8	48,9
	64,7 - 16,4	2,5 - 2,46	>3	MR ICI 50 - FVO 63 C 2.8	43,3

$P_1$ kW	$n_2$ $\text{min}^{-1}$	$M_2$ daN m	$f_{s \text{ min}}$ bei / at $n_2 \text{ min}$	Getriebe - Motor Gear reducer - Motor	$i$
3)				2)	
0,18 0,045	70,4 - 17,8	2,3 - 2,26	>3	MR ICI 50 - FVO 71 A 2.8	39,8
	89,2 - 22,6	1,81 - 1,79	>3	MR ICI 50 - FVO 71 A 2.8	31,4
	116 - 29,5	1,42 - 1,4	>3	MR CI 50 - FVO 63 C 2.8	24,1
4)	116 - 29,5	1,42 - 1,4	>3	MR CI 50 - FVO 71 A 2.8	24,1
	145 - 36,8	1,14 - 1,12	>3	MR CI 50 - FVO 63 C 2.8	19,3
	145 - 36,8	1,14 - 1,12	>3	MR CI 50 - FVO 71 A 2.8	19,3
	178 - 45,2	0,92 - 0,91	>3	MR CI 50 - FVO 63 C 2.8	15,7
	178 - 45,2	0,92 - 0,91	>3	MR CI 50 - FVO 71 A 2.8	15,7
	226 - 57,4	0,73 - 0,72	>3	MR CI 50 - FVO 63 C 2.8	12,4
	226 - 57,4	0,73 - 0,72	>3	MR CI 50 - FVO 71 A 2.8	12,4
	272 - 68,9	0,61 - 0,6	>3	MR CI 50 - FVO 63 C 2.8	10,3
	272 - 68,9	0,61 - 0,6	>3	MR CI 50 - FVO 71 A 2.8	10,3

2) Zur vollständigen Bestellbezeichnung s. Kap. 3. Auch **F0**-Ausführung «Normal-  
bremsmotor» vorgesehen.3) Leistungen bei Dauerbetrieb **S1**; bei Betriebsarten **S3 60** und **40%** können die Leistungen bis  
**18% gesteigert** werden;  $M_2$  steigt und  $f_s$  fällt proportional; bitte rückfragen.4) Auch Getriebegröße **40** zur Verfügung; bitte rückfragen.Bei der Bestimmung des Betriebsfaktors, **b** oder **c** als Belastung annehmen (Kap. 5).2) For complete designation when ordering see ch. 3. «Normal brake motor» design **F0**  
also possible.3) Powers valid for continuous duty **S1**; **18% increase** possible for **S3** duty **60** and **40%** in  
which case  $M_2$  increases and  $f_s$  decreases proportionately; consult us.4) Gear reducer size **40** also available; consult us.When determining service factor, assume nature of load **b** or **c** (ch. 5).

15 - Herstellungsprogramm (Kegelstirradtriebemotoren für Fahrtriebe)

15 - Manufacturing programme (right angle shafts for traverse movements)

2.8 pol.

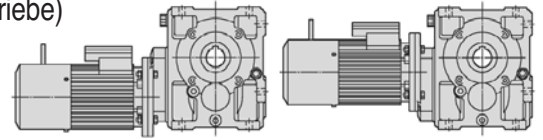

Table with columns: P1 (kW), n2 (min⁻¹), M2 (daN m), fs\_min (bei/at n2\_max), Getriebe - Motor / Gear reducer - Motor, i. Rows list various motor models and their specifications.

Table with columns: P1 (kW), n2 (min⁻¹), M2 (daN m), fs\_min (bei/at n2\_max), Getriebe - Motor / Gear reducer - Motor, i. Rows list various motor models and their specifications.

2) Zur vollständigen Bestellbezeichnung s. Kap. 3. Auch F0-Ausführung «Normalbremomotor» vorgesehen.
3) Leistungen bei Dauerbetrieb S1; bei Betriebsarten S3 60 und 40% können die Leistungen bis 18% gesteigert werden; Ms steigt und fs fällt proportional; bitte rückfragen.
4) Auch Getriebegröße 40 zur Verfügung; bitte rückfragen.
Bei der Bestimmung des Betriebsfaktors, b oder c als Belastung annehmen (Kap. 5).

2) For complete designation when ordering see ch. 3. «Normal brake motor» design F0 also possible.
3) Powers valid for continuous duty S1; 18% increase possible for S3 duty 60 and 40% in which case Ms increases and fs decreases proportionately; consult us.
4) Gear reducer size 40 also available; consult us.
When determining service factor, assume nature of load b or c (ch. 5).

15 - Herstellungsprogramm (Kegelstirnradgetriebemotoren für Fahrtriebe)  
15 - Manufacturing programme (right angle shafts for traverse movements)  
2.8 pol.

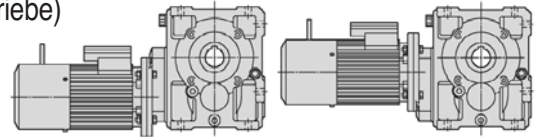

P <sub>1</sub> kW	n <sub>2</sub> min <sup>-1</sup>	M <sub>2</sub> daN m	f <sub>s</sub> min bei / at n <sub>2</sub> max	Getriebe - Motor Gear reducer - Motor	i
0,92 - 0,22	30,1 - 7,64	27,4 - 25,8	> 3	MR ICI 100 - FVO 90 L 2.8	92,9
	36,6 - 9,29	22,5 - 21,3	> 3	MR ICI 100 - FVO 90 L 2.8	76,4
	43,1 - 10,9	19,2 - 18,1	2,5	MR ICI 80 - FVO 90 L 2.8	65
	44,8 - 11,4	18,4 - 17,4	1,4	MR ICI 64 - FVO 90 L 2.8	62,5
	45,8 - 11,6	18 - 17	> 3	MR ICI 100 - FVO 90 L 2.8	61,2
	53,8 - 13,7	15,3 - 14,5	> 3	MR ICI 80 - FVO 90 L 2.8	52
	56 - 14,2	14,7 - 13,9	1,8	MR ICI 63 - FVO 90 L 2.8	50
	56 - 14,2	14,7 - 13,9	2,12	MR ICI 64 - FVO 90 L 2.8	50
	67,3 - 17,1	12,3 - 11,6	> 3	MR ICI 80 - FVO 90 L 2.8	41,6
	70 - 17,8	11,8 - 11,1	2,24	MR ICI 63 - FVO 90 L 2.8	40
	70 - 17,8	11,8 - 11,1	2,8	MR ICI 64 - FVO 90 L 2.8	40
	86,2 - 21,8	9,8 - 9,2	> 3	MR CI 80 - FVO 90 L 2.8	32,5
	87,5 - 22,2	9,4 - 8,9	2,8	MR ICI 63 - FVO 90 L 2.8	32
	89,6 - 22,7	9,4 - 8,9	2,12	MR CI 63 - FVO 90 L 2.8	31,3
	89,6 - 22,7	9,4 - 8,9	2,5	MR CI 64 - FVO 90 L 2.8	31,3
	111 - 28,1	7,4 - 7	> 3	MR ICI 63 - FVO 90 L 2.8	25,2
	112 - 28,4	7,5 - 7,1	> 3	MR CI 63 - FVO 90 L 2.8	25
	135 - 34,3	6,1 - 5,8	> 3	MR ICI 63 - FVO 90 L 2.8	20,7
	140 - 35,5	6 - 5,7	> 3	MR CI 63 - FVO 90 L 2.8	20
	175 - 44,4	4,82 - 4,55	> 3	MR CI 63 - FVO 90 L 2.8	16
	222 - 56,3	3,8 - 3,58	> 3	MR CI 63 - FVO 90 L 2.8	12,6
	270 - 68,5	3,12 - 2,94	> 3	MR CI 63 - FVO 90 L 2.8	10,4
1,1 - 0,28	22,1 - 5,6	43,7 - 43,9	3	MRC3I 100 - FVO 90 LA 2.8	127
	28 - 7,1	34,5 - 34,6	> 3	MRC3I 100 - FVO 90 LA 2.8	99,9
	30,1 - 7,64	32,8 - 32,9	> 3	MR ICI 100 - FVO 90 LA 2.8	92,9
	36,6 - 9,29	27 - 27,1	> 3	MR ICI 100 - FVO 90 LA 2.8	76,4
	43,1 - 10,9	22,9 - 23	2,12	MR ICI 80 - FVO 90 LA 2.8	65
	43,1 - 10,9	22,9 - 23	2,24	MR ICI 81 - FVO 90 LA 2.8	65
	45,8 - 11,6	21,6 - 21,6	> 3	MR ICI 100 - FVO 90 LA 2.8	61,2
	53,8 - 13,7	18,3 - 18,4	> 3	MR ICI 80 - FVO 90 LA 2.8	52
	56 - 14,2	17,6 - 17,7	1,5	MR ICI 63 - FVO 90 LA 2.8	50
	56 - 14,2	17,6 - 17,7	1,8	MR ICI 64 - FVO 90 LA 2.8	50
	67,3 - 17,1	14,7 - 14,7	> 3	MR ICI 80 - FVO 90 LA 2.8	41,6
	70 - 17,8	14,1 - 14,2	1,9	MR ICI 63 - FVO 90 LA 2.8	40
	70 - 17,8	14,1 - 14,2	2,36	MR ICI 64 - FVO 90 LA 2.8	40
	84 - 21,3	11,8 - 11,8	> 3	MR ICI 80 - FVO 90 LA 2.8	33,3
	86,2 - 21,8	11,7 - 11,8	> 3	MR CI 80 - FVO 90 LA 2.8	32,5
	87,5 - 22,2	11,3 - 11,3	2,36	MR ICI 63 - FVO 90 LA 2.8	32
	87,5 - 22,2	11,3 - 11,3	2,8	MR ICI 64 - FVO 90 LA 2.8	32
	89,6 - 22,7	11,3 - 11,3	1,8	MR CI 63 - FVO 90 LA 2.8	31,3
	89,6 - 22,7	11,3 - 11,3	2,12	MR CI 64 - FVO 90 LA 2.8	31,3
	108 - 27,3	9,4 - 9,4	> 3	MR CI 80 - FVO 90 LA 2.8	26
	111 - 28,1	8,9 - 8,9	> 3	MR ICI 63 - FVO 90 LA 2.8	25,2
	112 - 28,4	9 - 9	3	MR CI 63 - FVO 90 LA 2.8	25
	135 - 34,3	7,3 - 7,3	> 3	MR ICI 63 - FVO 90 LA 2.8	20,7
	140 - 35,5	7,2 - 7,2	> 3	MR CI 63 - FVO 90 LA 2.8	20
	175 - 44,4	5,8 - 5,8	> 3	MR CI 63 - FVO 90 LA 2.8	16
	222 - 56,3	4,54 - 4,56	> 3	MR CI 63 - FVO 90 LA 2.8	12,6
	270 - 68,5	3,73 - 3,75	> 3	MR CI 63 - FVO 90 LA 2.8	10,4
1,5 - 0,37	22,1 - 5,6	60 - 58	> 3	MRC3I 125 - FVO 100 LA 2.8	127
	22,1 - 5,6	60 - 58	2,24	MRC3I 100 - FVO 90 LB 2.8	127
	22,7 - 5,76	58 - 56	> 3	MRC3I 125 - FVO 90 LB 2.8	123
	28 - 7,1	47 - 45,8	3	MR C3I 100 - FVO 90 LB 2.8	99,9
	28,7 - 7,27	47 - 45,7	> 3	MR ICI 125 - FVO 100 LA 2.8	97,7
	30,1 - 7,64	44,7 - 43,5	2,5	MR ICI 100 - FVO 90 LB 2.8	92,9
	36,6 - 9,29	36,8 - 35,8	2,5	MR ICI 100 - FVO 90 LB 2.8	76,4
	38,2 - 9,7	35,2 - 34,3	3	MR ICI 100 - FVO 100 LA 2.8	73,2
	43,1 - 10,9	31,3 - 30,4	1,5	MR ICI 80 - FVO 90 LB 2.8	65
	43,1 - 10,9	31,3 - 30,4	1,7	MR ICI 81 - FVO 90 LB 2.8	65
	45,8 - 11,6	29,4 - 28,6	> 3	MR ICI 100 - FVO 90 LB 2.8	61,2
	46,5 - 11,8	29 - 28,2	> 3	MR ICI 100 - FVO 100 LA 2.8	60,2
	53,8 - 13,7	25 - 24,3	2,24	MR ICI 80 - FVO 90 LB 2.8	52
	53,8 - 13,7	25 - 24,3	2,65	MR ICI 81 - FVO 90 LB 2.8	52
	57,2 - 14,5	23,5 - 22,9	> 3	MR ICI 100 - FVO 90 LB 2.8	48,9
	58,1 - 14,7	23,2 - 22,5	> 3	MR ICI 100 - FVO 100 LA 2.8	48,2
	67,3 - 17,1	20 - 19,5	2,8	MR ICI 80 - FVO 90 LB 2.8	41,6

P <sub>1</sub> kW	n <sub>2</sub> min <sup>-1</sup>	M <sub>2</sub> daN m	f <sub>s</sub> min bei / at n <sub>2</sub> max	Getriebe - Motor Gear reducer - Motor	i
1,5 - 0,37	72,6 - 18,4	18,5 - 18	> 3	MR ICI 100 - FVO 100 LA 2.8	38,5
	76,5 - 19,4	18 - 17,5	> 3	MR CI 100 - FVO 90 LB 2.8	36,6
	76,5 - 19,4	18 - 17,5	> 3	MR CI 100 - FVO 100 LA 2.8	36,6
	84 - 21,3	16 - 15,6	> 3	MR ICI 80 - FVO 90 LB 2.8	33,3
	86,2 - 21,8	16 - 15,5	2,65	MR CI 80 - FVO 90 LB 2.8	32,5
	86,2 - 21,8	16 - 15,5	2,65	MR CI 80 - FVO 100 LA 2.8	32,5
	89,2 - 22,6	15,1 - 14,7	> 3	MR ICI 100 - FVO 100 LA 2.8	31,4
	89,6 - 22,7	15,3 - 14,9	1,32	MR CI 63 - FVO 90 LB 2.8	31,3
	89,6 - 22,7	15,3 - 14,9	1,5	MR CI 64 - FVO 90 LB 2.8	31,3
	93 - 23,6	14,8 - 14,4	> 3	MR CI 100 - FVO 90 LB 2.8	30,1
	93 - 23,6	14,8 - 14,4	> 3	MR CI 100 - FVO 100 LA 2.8	30,1
	107 - 27	12,6 - 12,3	> 3	MR ICI 80 - FVO 90 LB 2.8	26,3
	108 - 27,3	12,8 - 12,4	> 3	MR CI 80 - FVO 90 LB 2.8	26
	108 - 27,3	12,8 - 12,4	> 3	MR CI 80 - FVO 100 LA 2.8	26
	112 - 28,4	12,3 - 11,9	2,12	MR CI 63 - FVO 90 LB 2.8	25
	112 - 28,4	12,3 - 11,9	2,5	MR CI 64 - FVO 90 LB 2.8	25
	113 - 28,7	11,9 - 11,6	> 3	MR ICI 100 - FVO 100 LA 2.8	24,7
	135 - 34,1	10,2 - 9,9	> 3	MR CI 80 - FVO 100 LA 2.8	20,8
	136 - 34,5	9,9 - 9,6	> 3	MR ICI 100 - FVO 100 LA 2.8	20,6
	140 - 35,5	9,8 - 9,6	2,65	MR CI 63 - FVO 90 LB 2.8	20
	142 - 35,9	9,5 - 9,2	> 3	MR ICI 80 - FVO 90 LB 2.8	19,8
	168 - 42,6	8,2 - 8	> 3	MR CI 80 - FVO 100 LA 2.8	16,7
	175 - 44,4	7,9 - 7,6	> 3	MR CI 63 - FVO 90 LB 2.8	16
	213 - 54	6,5 - 6,3	> 3	MR CI 80 - FVO 100 LA 2.8	13,1
	222 - 56,3	6,2 - 6	> 3	MR CI 63 - FVO 90 LB 2.8	12,6
	270 - 68,5	5,1 - 4,95	> 3	MR CI 63 - FVO 90 LB 2.8	10,4
	283 - 71,8	4,85 - 4,72	> 3	MR CI 80 - FVO 100 LA 2.8	9,88
1,85 - 0,45	22,1 - 5,6	74 - 71	> 3	MRC3I 125 - FVO 100 LB 2.8	127
	28,7 - 7,27	58 - 56	> 3	MR ICI 125 - FVO 100 LB 2.8	97,7
	35,8 - 9,09	46,3 - 44,5	> 3	MR ICI 125 - FVO 100 LB 2.8	78,1
	38,2 - 9,7	43,4 - 41,7	2,5	MR ICI 100 - FVO 100 LB 2.8	73,2
	44,2 - 11,2	37,6 - 36,1	> 3	MR ICI 125 - FVO 100 LB 2.8	63,4
	46,5 - 11,8	35,7 - 34,3	2,5	MR ICI 100 - FVO 100 LB 2.8	60,2
	58,1 - 14,7	28,6 - 27,4	> 3	MR CI 100 - FVO 100 LB 2.8	48,2
	72,6 - 18,4	22,9 - 21,9	> 3	MR ICI 100 - FVO 100 LB 2.8	38,5
	76,5 - 19,4	22,2 - 21,3	> 3	MR CI 100 - FVO 100 LB 2.8	36,6
	86,2 - 21,8	19,7 - 18,9	2,12	MR CI 80 - FVO 100 LB 2.8	32,5
	86,2 - 21,8	19,7 - 18,9	2,65	MR CI 81 - FVO 100 LB 2.8	32,5
	89,2 - 22,6	18,6 - 17,9	> 3	MR ICI 100 - FVO 100 LB 2.8	31,4
	93 - 23,6	18,2 - 17,5	> 3	MR CI 100 - FVO 100 LB 2.8	30,1
	108 - 27,3	15,7 - 15,1	> 3	MR CI 80 - FVO 100 LB 2.8	26
	113 - 28,7	14,7 - 14,1	> 3	MR ICI 100 - FVO 100 LB 2.8	24,7
	135 - 34,1	12,6 - 12,1	> 3	MR CI 80 - FVO 100 LB 2.8	20,8
	136 - 34,5	12,2 - 11,7	> 3	MR ICI 100 - FVO 100 LB 2.8	20,6
	168 - 42,6	10,1 - 9,7	> 3	MR CI 80 - FVO 100 LB 2.8	16,7
	213 - 54	8 - 7,6	> 3	MR CI 80 - FVO 100 LB 2.8	13,1
	283 - 71,8	6 - 5,7	> 3	MR CI 80 - FVO 100 LB 2.8	9,88
2,2 - 0,55	22,1 - 5,6	88 - 86	> 3	MRC3I 125 - FVO 112 MA 2.8	127
	28,7 - 7,27	69 - 68	3	MR ICI 125 - FVO 112 MA 2.8	97,7
	35,8 - 9,09	55 - 54	> 3	MR ICI 125 - FVO 112 MA 2.8	78,1
	38,2 - 9,7	52 - 51	2,12	MR ICI 100 - FVO 112 MA 2.8	73,2
	44,2 - 11,2	44,7 - 44,1	> 3	MR ICI 125 - FVO 112 MA 2.8	63,4
	46,5 - 11,8	42,5 - 41,9	2,12	MR ICI 100 - FVO 112 MA 2.8	60,2
	58,1 - 14,7	34 - 33,5	> 3	MR ICI 100 - FVO 112 MA 2.8	48,2
	72,6 - 18,4	27,2 - 26,8	> 3	MR ICI 100 - FVO 112 MA 2.8	38,5
	76,5 - 19,4	26,4 - 26	> 3	MR CI 100 - FVO 112 MA 2.8	36,6
	86,2 - 21,8	23,4 - 23,1	1,8	MR CI 80 - FVO 112 MA 2.8	32,5
	86,2 - 21,8	23,4 - 23,1	2,12	MR CI 81 - FVO 112 MA 2.8	32,5
	89,2 - 22,6	22,1 - 21,8	> 3	MR ICI 100 - FVO 112 MA 2.8	31,4
	93 - 23,6	21,7 - 21,4	> 3	MR CI 100 - FVO 112 MA 2.8	30,1
	108 - 27,3	18,7 - 18,5	3	MR CI 80 - FVO 112 MA 2.8	26
	113 - 28,7	17,5 - 17,2	> 3	MR ICI 100 - FVO 112 MA 2.8	24,7
	116 - 29,5	17,4 - 17,1	> 3	MR CI 100 - FVO 112 MA 2.8	24,1
	135 - 34,1	15 - 14,8	> 3	MR CI 80 - FVO 112 MA 2.8	20,8
	136 - 34,5	14,5 - 14,3	> 3	MR ICI 100 - FVO 112 MA 2.8	20,6
	168 - 42,6	12 - 11,8	> 3	MR CI 80 - FVO 112 MA 2.8	16,7
	213 - 54	9,5 - 9,3	> 3	MR CI 80 - FVO 112 MA 2.8	13,1
	283 - 71,8	7,1 - 7	> 3	MR CI 80 - FVO 112 MA 2.8	9,88

2) Zur vollständigen Bestellbezeichnung s. Kap. 3. Auch FO-Ausführung «Normalbrensmotor» vorgesehen.  
3) Leistungen bei Dauerbetrieb S1; bei Betriebsarten S3 60 und 40% können die Leistungen bis 18% gesteigert werden; M<sub>2</sub> steigt und f<sub>s</sub> fällt proportional; bitte rückfragen.  
Bei der Bestimmung des Betriebsfaktors, b oder c als Belastung annehmen (Kap. 5).

2) For complete designation when ordering see ch. 3. «Normal brake motor» design FO also possible.  
3) Powers valid for continuous duty S1; 18% increase possible for S3 duty 60 and 40% in which case M<sub>2</sub> increases and f<sub>s</sub> decreases proportionately; consult us.  
When determining service factor, assume nature of load b or c (ch. 5).

15 - Herstellungsprogramm (Kegelstirnradgetriebemotoren für Fahrtriebe)  
15 - Manufacturing programme (right angle shafts for traverse movements)  
2.8 pol.

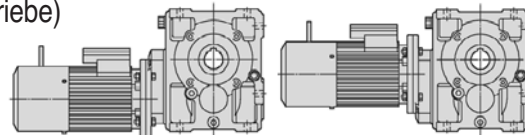

$P_1$ kW	$n_2$ min <sup>-1</sup>	$M_2$ daN m	$f_{s_{min}}$ bei / at $n_{2_{max}}$	Getriebe - Motor Gear reducer - Motor	$i$
3)				2)	
<b>3</b> 0,75	22,1 - 5,6	119 - 118	2,24	MR C3I 125 - FV0 112 MB 2.8	127
	28 - 7,1	94 - 93	3	MR C3I 125 - FV0 112 MB 2.8	100
	28,7 - 7,27	94 - 93	2,12	MR ICI 125 - FV0 112 MB 2.8	97,7
	35,8 - 9,09	75 - 74	>3	MR ICI 125 - FV0 112 MB 2.8	78,1
	38,2 - 9,7	70 - 69	1,5	MR ICI 100 - FV0 112 MB 2.8	73,2
	44,2 - 11,2	61 - 60	>3	MR ICI 125 - FV0 112 MB 2.8	63,4
	46,5 - 11,8	58 - 57	1,5	MR ICI 100 - FV0 112 MB 2.8	60,2
	55,2 - 14	48,8 - 48,1	>3	MR ICI 125 - FV0 112 MB 2.8	50,7
	58,1 - 14,7	46,3 - 45,7	2,65	MR ICI 100 - FV0 112 MB 2.8	48,2
	72,6 - 18,4	37,1 - 36,6	>3	MR ICI 100 - FV0 112 MB 2.8	38,5
	76,5 - 19,4	36 - 35,5	2,65	MR CI 100 - FV0 112 MB 2.8	36,6
	86,2 - 21,8	31,9 - 31,5	1,32	MR CI 80 - FV0 112 MB 2.8	32,5
	86,2 - 21,8	31,9 - 31,5	1,6	MR CI 81 - FV0 112 MB 2.8	32,5
	89,2 - 22,6	30,2 - 29,8	>3	MR ICI 100 - FV0 112 MB 2.8	31,4
	93 - 23,6	29,6 - 29,2	3	MR CI 100 - FV0 112 MB 2.8	30,1
	108 - 27,3	25,5 - 25,2	2,24	MR CI 80 - FV0 112 MB 2.8	26
	108 - 27,3	25,5 - 25,2	2,5	MR CI 81 - FV0 112 MB 2.8	26
	113 - 28,7	23,8 - 23,5	>3	MR ICI 100 - FV0 112 MB 2.8	24,7
	116 - 29,5	23,7 - 23,3	>3	MR CI 100 - FV0 112 MB 2.8	24,1
	135 - 34,1	20,4 - 20,1	2,8	MR CI 80 - FV0 112 MB 2.8	20,8
	136 - 34,5	19,8 - 19,5	>3	MR ICI 100 - FV0 112 MB 2.8	20,6
	145 - 36,8	18,9 - 18,7	>3	MR CI 100 - FV0 112 MB 2.8	19,3
	168 - 42,6	16,4 - 16,1	>3	MR CI 80 - FV0 112 MB 2.8	16,7
	213 - 54	12,9 - 12,7	>3	MR CI 80 - FV0 112 MB 2.8	13,1
283 - 71,8	9,7 - 9,6	>3	MR CI 80 - FV0 112 MB 2.8	9,88	
<b>4</b> 1,1	44,1 - 11,2	81 - 88	2,36	MR ICI 125 - FV0 132 S 2.8	63,4
	55,2 - 14	65 - 71	>3	MR ICI 125 - FV0 132 S 2.8	50,8
	69 - 17,5	52 - 56	>3	MR ICI 125 - FV0 132 S 2.8	40,6
	76,5 - 19,4	47,9 - 52	1,9	MR CI 100 - FV0 132 S 2.8	36,6
	86,2 - 21,9	41,7 - 45,2	>3	MR ICI 125 - FV0 132 S 2.8	32,5
	89,6 - 22,7	40,9 - 44,4	>3	MR CI 125 - FV0 132 S 2.8	31,3
	93 - 23,6	39,4 - 42,8	2,12	MR CI 100 - FV0 132 S 2.8	30,1
	109 - 27,7	32,8 - 35,6	>3	MR ICI 125 - FV0 132 S 2.8	25,6
	112 - 28,4	32,7 - 35,5	>3	MR CI 125 - FV0 132 S 2.8	25

$P_1$ kW	$n_2$ min <sup>-1</sup>	$M_2$ daN m	$f_{s_{min}}$ bei / at $n_{2_{max}}$	Getriebe - Motor Gear reducer - Motor	$i$	
3)				2)		
<b>4</b> 1,1	116 - 29,5	31,6 - 34,2	>3	MR CI 100 - FV0 132 S 2.8	24,1	
	133 - 33,7	27 - 29,3	>3	MR ICI 125 - FV0 132 S 2.8	21	
	145 - 36,8	25,2 - 27,4	>3	MR CI 100 - FV0 132 S 2.8	19,3	
	178 - 45,2	20,6 - 22,3	>3	MR CI 100 - FV0 132 S 2.8	15,7	
	226 - 57,4	16,2 - 17,6	>3	MR CI 100 - FV0 132 S 2.8	12,4	
	272 - 68,9	13,5 - 14,6	>3	MR CI 100 - FV0 132 S 2.8	10,3	
	<b>5,5</b> 1,5	44,1 - 11,2	112 - 120	1,8	MR ICI 125 - FV0 132 MA 2.8	63,4
		55,2 - 14	90 - 96	2,5	MR ICI 125 - FV0 132 MA 2.8	50,8
		69 - 17,5	72 - 77	>3	MR ICI 125 - FV0 132 MA 2.8	40,6
		76,5 - 19,4	66 - 71	1,4	MR CI 100 - FV0 132 MA 2.8	36,6
		86,2 - 21,9	57 - 62	>3	MR ICI 125 - FV0 132 MA 2.8	32,5
		89,6 - 22,7	56 - 61	2,8	MR CI 125 - FV0 132 MA 2.8	31,3
		93 - 23,6	54 - 58	1,6	MR CI 100 - FV0 132 MA 2.8	30,1
		109 - 27,7	45,2 - 48,6	>3	MR ICI 125 - FV0 132 MA 2.8	25,6
		112 - 28,4	45 - 48,4	>3	MR CI 125 - FV0 132 MA 2.8	25
		116 - 29,5	43,4 - 46,7	2,36	MR CI 100 - FV0 132 MA 2.8	24,1
		133 - 33,7	37,1 - 39,9	>3	MR ICI 125 - FV0 132 MA 2.8	21
		140 - 35,5	36 - 38,7	>3	MR CI 125 - FV0 132 MA 2.8	20
		145 - 36,8	34,7 - 37,3	>3	MR CI 100 - FV0 132 MA 2.8	19,3
		178 - 45,2	28,3 - 30,4	>3	MR CI 100 - FV0 132 MA 2.8	15,7
		226 - 57,4	22,3 - 24	>3	MR CI 100 - FV0 132 MA 2.8	12,4
272 - 68,9		18,6 - 20	>3	MR CI 100 - FV0 132 MA 2.8	10,3	
<b>7,5</b> 2,1		44,1 - 11,2	153 - 168	1,32	MR ICI 125 - FV0 132 MB 2.8	63,4
		55,2 - 14	122 - 135	1,8	MR ICI 125 - FV0 132 MB 2.8	50,8
		69 - 17,5	98 - 108	2,24	MR ICI 125 - FV0 132 MB 2.8	40,6
	86,2 - 21,9	78 - 86	>3	MR ICI 125 - FV0 132 MB 2.8	32,5	
	89,6 - 22,7	77 - 85	2,12	MR CI 125 - FV0 132 MB 2.8	31,3	
	109 - 27,7	62 - 68	>3	MR ICI 125 - FV0 132 MB 2.8	25,6	
	112 - 28,4	61 - 68	>3	MR CI 125 - FV0 132 MB 2.8	25	
	133 - 33,7	51 - 56	>3	MR ICI 125 - FV0 132 MB 2.8	21	
	140 - 35,5	49,1 - 54	>3	MR CI 125 - FV0 132 MB 2.8	20	
	175 - 44,4	39,3 - 43,4	>3	MR CI 125 - FV0 132 MB 2.8	16	
	222 - 56,3	31 - 34,2	>3	MR ICI 125 - FV0 132 MB 2.8	12,6	
	270 - 68,5	25,4 - 28,1	>3	MR CI 125 - FV0 132 MB 2.8	10,4	

2.12 pol.

$P_1$ kW	$n_2$ min <sup>-1</sup>	$M_2$ daN m	$f_{s_{min}}$ bei / at $n_{2_{max}}$	Getriebe - Motor Gear reducer - Motor	$i$
3)				2)	
<b>0,3</b> 0,045	21,7 - 3,48	12,2 - 11,4	2,5	MR C3I 63 - FV0 80 A 2.12	129
	27,5 - 4,42	9,6 - 9	>3	MR C3I 63 - FV0 80 A 2.12	102
	35,3 - 5,67	7,6 - 7,1	3	MR ICI 63 - FV0 80 A 2.12	79,3
	44,1 - 7,09	6,1 - 5,7	>3	MR ICI 63 - FV0 80 A 2.12	63,5
	57,2 - 9,2	4,7 - 4,39	3	MR ICI 50 - FV0 80 A 2.12	48,9
	71,6 - 11,5	3,76 - 3,51	>3	MR ICI 50 - FV0 80 A 2.12	39,1
	87,9 - 14,1	3,06 - 2,86	>3	MR ICI 50 - FV0 80 A 2.12	31,9
	89,6 - 14,4	3,07 - 2,87	>3	MR CI 63 - FV0 80 A 2.12	31,3
	111 - 17,9	2,42 - 2,26	>3	MR ICI 50 - FV0 80 A 2.12	25,1
	116 - 18,7	2,37 - 2,21	>3	MR CI 50 - FV0 80 A 2.12	24,1
	134 - 21,5	2,01 - 1,88	>3	MR ICI 50 - FV0 80 A 2.12	20,9
	145 - 23,3	1,89 - 1,77	>3	MR CI 50 - FV0 80 A 2.12	19,3
	178 - 28,7	1,54 - 1,44	>3	MR CI 50 - FV0 80 A 2.12	15,7
	226 - 36,4	1,22 - 1,13	>3	MR CI 50 - FV0 80 A 2.12	12,4
	272 - 43,7	1,01 - 0,94	>3	MR CI 50 - FV0 80 A 2.12	10,3
	<b>0,45</b> 0,07	20,8 - 3,34	19 - 18,4	>3	MR C3I 80 - FV0 80 B 2.12
21,7 - 3,48		18,2 - 17,7	1,7	MR C3I 63 - FV0 80 B 2.12	129
21,7 - 3,48		18,2 - 17,7	1,9	MR C3I 64 - FV0 80 B 2.12	129
26,4 - 4,24		15 - 14,5	>3	MR C3I 80 - FV0 80 B 2.12	106
27,5 - 4,42		14,4 - 13,9	2,24	MR C3I 63 - FV0 80 B 2.12	102
27,5 - 4,42		14,4 - 13,9	2,65	MR C3I 64 - FV0 80 B 2.12	102
33,9 - 5,45		11,9 - 11,5	>3	MR ICI 80 - FV0 80 B 2.12	82,5
35,3 - 5,67		11,4 - 11,1	1,9	MR ICI 63 - FV0 80 B 2.12	79,3
35,3 - 5,67		11,4 - 11,1	2,36	MR ICI 64 - FV0 80 B 2.12	79,3

$P_1$ kW	$n_2$ min <sup>-1</sup>	$M_2$ daN m	$f_{s_{min}}$ bei / at $n_{2_{max}}$	Getriebe - Motor Gear reducer - Motor	$i$	
3)				2)		
<b>0,45</b> 0,07	44,1 - 7,09	9,2 - 8,9	3	MR ICI 63 - FV0 80 B 2.12	63,5	
	55,2 - 8,86	7,3 - 7,1	>3	MR ICI 63 - FV0 80 B 2.12	50,8	
	57,2 - 9,2	7,1 - 6,8	2	MR ICI 50 - FV0 80 B 2.12	48,9	
	68,9 - 11,1	5,9 - 5,7	>3	MR ICI 63 - FV0 80 B 2.12	40,6	
	71,6 - 11,5	5,6 - 5,5	2,5	MR ICI 50 - FV0 80 B 2.12	39,1	
	87,9 - 14,1	4,6 - 4,45	>3	MR ICI 50 - FV0 80 B 2.12	31,9	
	89,6 - 14,4	4,6 - 4,46	>3	MR CI 63 - FV0 80 B 2.12	31,3	
	111 - 17,9	3,62 - 3,51	>3	MR ICI 50 - FV0 80 B 2.12	25,1	
	116 - 18,7	3,55 - 3,44	>3	MR CI 50 - FV0 80 B 2.12	24,1	
	134 - 21,5	3,02 - 2,92	>3	MR ICI 50 - FV0 80 B 2.12	20,9	
	145 - 23,3	2,84 - 2,75	>3	MR CI 50 - FV0 80 B 2.12	19,3	
	178 - 28,7	2,31 - 2,24	>3	MR CI 50 - FV0 80 B 2.12	15,7	
	226 - 36,4	1,82 - 1,76	>3	MR CI 50 - FV0 80 B 2.12	12,4	
	272 - 43,7	1,52 - 1,47	>3	MR CI 50 - FV0 80 B 2.12	10,3	
	<b>0,75</b> 0,11	22,1 - 3,55	29,8 - 27,2	>3	MR C3I 100 - FV0 90 LA 2.12	127
		28 - 4,5	23,5 - 21,5	>3	MR C3I 100 - FV0 90 LA 2.12	99,9
		30,1 - 4,84	22,3 - 20,4	>3	MR ICI 100 - FV0 90 LA 2.12	92,9
		36,6 - 5,89	18,4 - 16,8	>3	MR ICI 100 - FV0 90 LA 2.12	76,4
		43,1 - 6,92	15,6 - 14,3	>3	MR ICI 80 - FV0 90 LA 2.12	65
		44,8 - 7,2	15 - 13,7	1,5	MR ICI 63 - FV0 90 LA 2.12	62,5
44,8 - 7,2		15 - 13,7	1,8	MR ICI 64 - FV0 90 LA 2.12	62,5	
53,8 - 8,65		12,5 - 11,4	>3	MR ICI 80 - FV0 90 LA 2.12	52	
56 - 9		12 - 11	2,24	MR ICI 63 - FV0 90 LA 2.12	50	
56 - 9		12 - 11	2,65	MR ICI 64 - FV0 90 LA 2.12	50	

2) Zur vollständigen Bestellbezeichnung s. Kap. 3. Auch **F0**-Ausführung «Normalbremsmotor» vorgesehen.  
3) Leistungen bei Dauerbetrieb **S3 60** und **40%** können die Leistungen bis **18% gesteigert** werden;  $M_2$  steigt und  $f_s$  fällt proportional; bitte rückfragen.  
Bei der Bestimmung des Betriebsfaktors, **b** oder **c** als Belastung annehmen (Kap. 5).

2) For complete designation when ordering see ch. 3. «Normal brake motor» design **F0** also possible.  
3) Powers valid for continuous duty **S1**; **18% increase** possible for **S3** duty **60** and **40%** in which case  $M_2$  increases and  $f_s$  decreases proportionately; consult us.  
When determining service factor, assume nature of load **b** or **c** (ch. 5).

15 - Herstellungsprogramm (Kegelstirnradgetriebemotoren für Fahrantriebe)  
15 - Manufacturing programme (right angle shafts for traverse movements)  
2.12 pol.

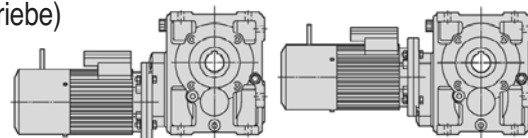

P <sub>1</sub> kW 3)	n <sub>2</sub> min <sup>-1</sup>	M <sub>2</sub> daN m	f <sub>s</sub> <sub>min</sub> bei / at n <sub>2</sub> max	Getriebe - Motor Gear reducer - Motor 2)	i	
0,75 - 0,11	67,3 - 10,8	10 - 9,1	> 3	MR ICI 80 - FVO 90 LA 2.12	41,6	
	70 - 11,3	9,6 - 8,8	2,8	MR ICI 63 - FVO 90 LA 2.12	40	
	86,2 - 13,8	8 - 7,3	> 3	MR CI 80 - FVO 90 LA 2.12	32,5	
	87,5 - 14,1	7,7 - 7	> 3	MR CI 63 - FVO 90 LA 2.12	32	
	89,6 - 14,4	7,7 - 7	2,65	MR CI 63 - FVO 90 LA 2.12	31,3	
	111 - 17,8	6,1 - 5,5	> 3	MR ICI 63 - FVO 90 LA 2.12	25,2	
	112 - 18	6,1 - 5,6	> 3	MR CI 63 - FVO 90 LA 2.12	25	
	135 - 21,7	4,98 - 4,55	> 3	MR CI 63 - FVO 90 LA 2.12	20,7	
	140 - 22,5	4,91 - 4,48	> 3	MR CI 63 - FVO 90 LA 2.12	20	
	175 - 28,1	3,93 - 3,59	> 3	MR CI 63 - FVO 90 LA 2.12	16	
	222 - 35,7	3,1 - 2,83	> 3	MR CI 63 - FVO 90 LA 2.12	12,6	
	270 - 43,4	2,54 - 2,32	> 3	MR CI 63 - FVO 90 LA 2.12	10,4	
	1,1 - 0,15	22,1 - 3,55	43,7 - 37,1	3	MR C3I 100 - FVO 90 LB 2.12	127
		28 - 4,5	34,5 - 29,3	> 3	MR C3I 100 - FVO 90 LB 2.12	99,9
		30,1 - 4,84	32,8 - 27,8	> 3	MR ICI 100 - FVO 90 LB 2.12	92,9
		36,6 - 5,89	27 - 22,9	> 3	MR ICI 100 - FVO 90 LB 2.12	76,4
		43,1 - 6,92	22,9 - 19,5	2,12	MR ICI 80 - FVO 90 LB 2.12	65
43,1 - 6,92		22,9 - 19,5	2,24	MR ICI 81 - FVO 90 LB 2.12	65	
45,8 - 7,36		21,6 - 18,3	> 3	MR ICI 100 - FVO 90 LB 2.12	61,2	
53,8 - 8,65		18,3 - 15,6	> 3	MR ICI 80 - FVO 90 LB 2.12	52	
56 - 9		17,6 - 15	1,5	MR ICI 63 - FVO 90 LB 2.12	50	
56 - 9		17,6 - 15	1,8	MR ICI 64 - FVO 90 LB 2.12	50	
67,3 - 10,8		14,7 - 12,4	> 3	MR ICI 80 - FVO 90 LB 2.12	41,6	
70 - 11,3		14,1 - 12	1,9	MR ICI 63 - FVO 90 LB 2.12	40	
70 - 11,3		14,1 - 12	2,36	MR ICI 64 - FVO 90 LB 2.12	40	
84 - 13,5		11,8 - 10	> 3	MR ICI 80 - FVO 90 LB 2.12	33,3	
86,2 - 13,8		11,7 - 9,9	> 3	MR CI 80 - FVO 90 LB 2.12	32,5	
87,5 - 14,1		11,3 - 9,6	2,36	MR ICI 63 - FVO 90 LB 2.12	32	
87,5 - 14,1		11,3 - 9,6	2,8	MR ICI 64 - FVO 90 LB 2.12	32	
89,6 - 14,4		11,3 - 9,6	1,8	MR CI 63 - FVO 90 LB 2.12	31,3	
89,6 - 14,4		11,3 - 9,6	2,12	MR CI 64 - FVO 90 LB 2.12	31,3	
108 - 17,3		9,4 - 7,9	> 3	MR CI 80 - FVO 90 LB 2.12	26	
111 - 17,8		8,9 - 7,5	> 3	MR ICI 63 - FVO 90 LB 2.12	25,2	
112 - 18		9 - 7,6	3	MR CI 63 - FVO 90 LB 2.12	25	
135 - 21,7	7,3 - 6,2	> 3	MR ICI 63 - FVO 90 LB 2.12	20,7		
140 - 22,5	7,2 - 6,1	> 3	MR CI 63 - FVO 90 LB 2.12	20		
175 - 28,1	5,8 - 4,89	> 3	MR CI 63 - FVO 90 LB 2.12	16		
222 - 35,7	4,54 - 3,86	> 3	MR CI 63 - FVO 90 LB 2.12	12,6		
270 - 43,4	3,73 - 3,17	> 3	MR CI 63 - FVO 90 LB 2.12	10,4		

P <sub>1</sub> kW 3)	n <sub>2</sub> min <sup>-1</sup>	M <sub>2</sub> daN m	f <sub>s</sub> <sub>min</sub> bei / at n <sub>2</sub> max	Getriebe - Motor Gear reducer - Motor 2)	i	
1,85 - 0,27	22,1 - 3,55	74 - 67	> 3	MR C3I 125 - FVO 100 LB 2.12	127	
	28,7 - 4,61	58 - 53	> 3	MR ICI 125 - FVO 100 LB 2.12	97,7	
	35,8 - 5,76	46,3 - 42,1	> 3	MR ICI 125 - FVO 100 LB 2.12	78,1	
	38,2 - 6,15	43,4 - 39,4	2,5	MR ICI 100 - FVO 100 LB 2.12	73,2	
	44,2 - 7,1	37,6 - 34,1	> 3	MR ICI 125 - FVO 100 LB 2.12	63,4	
	46,5 - 7,47	35,7 - 32,4	2,5	MR ICI 100 - FVO 100 LB 2.12	60,2	
	58,1 - 9,34	28,6 - 26	> 3	MR ICI 100 - FVO 100 LB 2.12	48,2	
	72,6 - 11,7	22,9 - 20,8	> 3	MR ICI 100 - FVO 100 LB 2.12	38,5	
	76,5 - 12,3	22,2 - 20,1	> 3	MR CI 100 - FVO 100 LB 2.12	36,6	
	86,2 - 13,8	19,7 - 17,9	2,12	MR CI 80 - FVO 100 LB 2.12	32,5	
	86,2 - 13,8	19,7 - 17,9	2,65	MR CI 81 - FVO 100 LB 2.12	32,5	
	89,2 - 14,3	18,6 - 16,9	> 3	MR ICI 100 - FVO 100 LB 2.12	31,4	
	93 - 14,9	18,2 - 16,6	> 3	MR CI 100 - FVO 100 LB 2.12	30,1	
	108 - 17,3	15,7 - 14,3	> 3	MR CI 80 - FVO 100 LB 2.12	26	
	113 - 18,2	14,7 - 13,3	> 3	MR ICI 100 - FVO 100 LB 2.12	24,7	
	135 - 21,6	12,6 - 11,4	> 3	MR CI 80 - FVO 100 LB 2.12	20,8	
	136 - 21,8	12,2 - 11,1	> 3	MR ICI 100 - FVO 100 LB 2.12	20,6	
168 - 27	10,1 - 9,2	> 3	MR CI 80 - FVO 100 LB 2.12	16,7		
213 - 34,2	8 - 7,2	> 3	MR CI 80 - FVO 100 LB 2.12	13,1		
283 - 45,5	6 - 5,4	> 3	MR CI 80 - FVO 100 LB 2.12	9,88		
2,2 - 0,33	22,1 - 3,55	88 - 82	> 3	MR C3I 125 - FVO 112 MA 2.12	127	
	28,7 - 4,61	69 - 64	3	MR ICI 125 - FVO 112 MA 2.12	97,7	
	35,8 - 5,76	55 - 51	> 3	MR ICI 125 - FVO 112 MA 2.12	78,1	
	38,2 - 6,15	52 - 48,2	2,12	MR ICI 100 - FVO 112 MA 2.12	73,2	
	44,2 - 7,1	44,7 - 41,7	> 3	MR ICI 125 - FVO 112 MA 2.12	63,4	
	46,5 - 7,47	42,5 - 39,6	2,12	MR ICI 100 - FVO 112 MA 2.12	60,2	
	58,1 - 9,34	34 - 31,7	> 3	MR ICI 100 - FVO 112 MA 2.12	48,2	
	72,6 - 11,7	27,2 - 25,4	> 3	MR ICI 100 - FVO 112 MA 2.12	38,5	
	76,5 - 12,3	26,4 - 24,6	> 3	MR CI 100 - FVO 112 MA 2.12	36,6	
	86,2 - 13,8	23,4 - 21,9	1,8	MR CI 80 - FVO 112 MA 2.12	32,5	
	86,2 - 13,8	23,4 - 21,9	2,12	MR CI 81 - FVO 112 MA 2.12	32,5	
	89,2 - 14,3	22,1 - 20,7	> 3	MR ICI 100 - FVO 112 MA 2.12	31,4	
	93 - 14,9	21,7 - 20,2	> 3	MR CI 100 - FVO 112 MA 2.12	30,1	
	108 - 17,3	18,7 - 17,5	3	MR CI 80 - FVO 112 MA 2.12	26	
	113 - 18,2	17,5 - 16,3	> 3	MR ICI 100 - FVO 112 MA 2.12	24,7	
	135 - 21,6	15 - 14	> 3	MR CI 80 - FVO 112 MA 2.12	20,8	
	136 - 21,8	14,5 - 13,6	> 3	MR ICI 100 - FVO 112 MA 2.12	20,6	
	168 - 27	12 - 11,2	> 3	MR CI 80 - FVO 112 MA 2.12	16,7	
	213 - 34,2	9,5 - 8,8	> 3	MR CI 80 - FVO 112 MA 2.12	13,1	
	283 - 45,5	7,1 - 6,6	> 3	MR CI 80 - FVO 112 MA 2.12	9,88	
	3 - 0,42	22,1 - 3,55	119 - 104	2,24	MR C3I 125 - FVO 112 MB 2.12	127
		28,7 - 4,61	94 - 82	2,12	MR ICI 125 - FVO 112 MB 2.12	97,7
35,8 - 5,76		75 - 65	> 3	MR ICI 125 - FVO 112 MB 2.12	78,1	
38,2 - 6,15		70 - 61	1,5	MR ICI 100 - FVO 112 MB 2.12	73,2	
44,2 - 7,1		61 - 53	> 3	MR ICI 125 - FVO 112 MB 2.12	63,4	
46,5 - 7,47		58 - 50	1,5	MR ICI 100 - FVO 112 MB 2.12	60,2	
55,2 - 8,87		48,8 - 42,5	> 3	MR ICI 125 - FVO 112 MB 2.12	50,7	
58,1 - 9,34		46,3 - 40,4	2,65	MR ICI 100 - FVO 112 MB 2.12	48,2	
72,6 - 11,7		37,1 - 32,3	> 3	MR ICI 100 - FVO 112 MB 2.12	38,5	
76,5 - 12,3		36 - 31,3	2,65	MR CI 100 - FVO 112 MB 2.12	36,6	
86,2 - 13,8		31,9 - 27,8	1,32	MR CI 80 - FVO 112 MB 2.12	32,5	
86,2 - 13,8		31,9 - 27,8	1,6	MR CI 81 - FVO 112 MB 2.12	32,5	
89,2 - 14,3		30,2 - 26,3	> 3	MR ICI 100 - FVO 112 MB 2.12	31,4	
93 - 14,9		29,6 - 25,8	3	MR CI 100 - FVO 112 MB 2.12	30,1	
108 - 17,3		25,5 - 22,2	2,24	MR CI 80 - FVO 112 MB 2.12	26	
108 - 17,3		25,5 - 22,2	2,5	MR CI 81 - FVO 112 MB 2.12	26	
113 - 18,2		23,8 - 20,7	> 3	MR ICI 100 - FVO 112 MB 2.12	24,7	
116 - 18,7		23,7 - 20,6	> 3	MR CI 100 - FVO 112 MB 2.12	24,1	
135 - 21,6		20,4 - 17,8	2,8	MR CI 80 - FVO 112 MB 2.12	20,8	
136 - 21,8		19,8 - 17,3	> 3	MR ICI 100 - FVO 112 MB 2.12	20,6	
145 - 23,3		18,9 - 16,5	> 3	MR CI 100 - FVO 112 MB 2.12	19,3	
168 - 27		16,4 - 14,3	> 3	MR CI 80 - FVO 112 MB 2.12	16,7	
213 - 34,2	12,9 - 11,2	> 3	MR CI 80 - FVO 112 MB 2.12	13,1		
283 - 45,5	9,7 - 8,5	> 3	MR CI 80 - FVO 112 MB 2.12	9,88		

2) Zur vollständigen Bestellbezeichnung s. Kap. 3. Auch F0-Ausführung «Normal-bremsmotor» vorgesehen.

3) Leistungen bei Dauerbetrieb S1; bei Betriebsarten S3 60 und 40% können die Leistungen bis 18% gesteigert werden; M<sub>2</sub> steigt und f<sub>s</sub> fällt proportional; bitte rückfragen.

Bei der Bestimmung des Betriebsfaktors, b oder c als Belastung annehmen (Kap. 5).

2) For complete designation when ordering see ch. 3. «Normal brake motor» design F0 also possible.

3) Powers valid for continuous duty S1; 18% increase possible for S3 duty 60 and 40% in which case M<sub>2</sub> increases and f<sub>s</sub> decreases proportionately; consult us.

When determining service factor, assume nature of load b or c (ch. 5).

# 16 - Bauarten, Abmessungen, Bauformen und Ölmengen

# 16 - Designs, dimensions, mounting positions and oil quantities

MR CI 40 ... 100

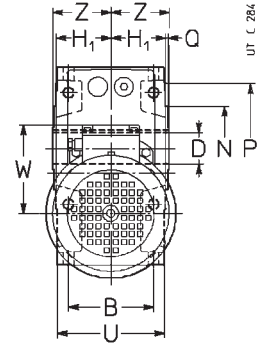
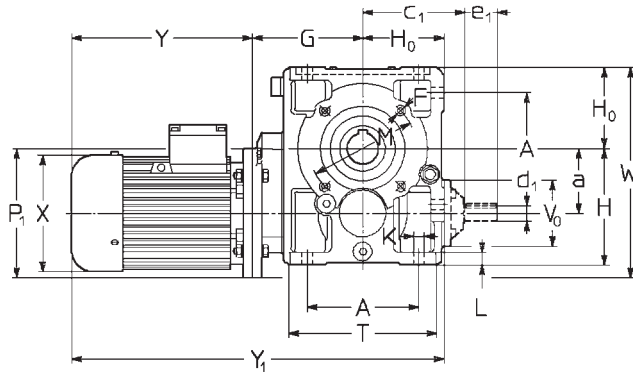

## Bauart<sup>1)</sup> (Dreh Sinn)

## Design<sup>1)</sup> (direction of rotation)

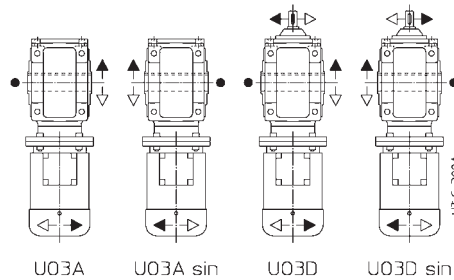

● Position der Bezugsrille (s. Kap. 20) zur Ermittlung der Radialbelastung.

● Position of the reference groove (see ch. 20) for verification of radial load.

Größe Size	a	A	c <sub>1</sub>	D Ø H7	d <sub>1</sub> Ø	e <sub>1</sub>	d <sub>1</sub> Ø	e <sub>1</sub>	F	G	H	H <sub>0</sub>	H <sub>1</sub>	K Ø	L	M	N Ø h6	P	Q	T	V <sub>0</sub>	Z	P <sub>1</sub> Ø	X Ø ≈	Y ≈	Y <sub>1</sub> ≈	W ≈	W <sub>1</sub> ≈	Masse Mass kg			
																														Getr. red.	Motor motor	B
40	63 71 <sup>4)</sup>	41,5 73 65	74	19	11	23	11	23	M5	87	82	56	41,5	7	10	75	60	90	2,5	102 80	43	46	140 160	122 140	185 211	229 275	328 354	372 418	101 112	168 178	11 14	13 17
50	63 71 80 <sup>4)</sup>	50 86 75	94	24	16	30	14	30	M6	98	100	67	49	9,5	12	85	70	105	2,5	120 95	78	53	140 160 200 <sup>5)</sup>	122 140 160	185 211 231	229 275 307	350 376 440	394 440 472	101 112 122	187 197 222	15 18 22	17 21 27
63 64	71 80 90 100 <sup>6)</sup>	63 102 90	108	30 (63) 32 (64)	16	30	14	30	M8	118	125	80	58,5	11,5	14	100	80	120	3	143 114	78	63	160 200 160 200 200	140 160 211 275 307	211 231 275 307 343	275 307 376 440 505	409 473 505 553	473 505 553	112 122 149	223 243 243	23 27 33	26 32 38
80 81	80 90 100 <sup>7)</sup> *112 <sup>7)</sup>	80 132 106	131	38 (80) 40 (81)	19	40	16	30	M10	138 148	150	100	69,5	14	17	130	110	160	3,5	180 135	86	75	200 200 200 250 250	160 180 231 307 343	231 270 307 355 419	307 355 429 505 591	469 508 593 667	545 593 667	122 149 164	280 280 305	38 44 51	43 49 58
100	90 100 112 *132 <sup>7)</sup>	100 172 131	157	48	24	50	19	40	M12	170 190	180	125	84,5	16	20	165	130	200	3,5	228 165	104	90	200 250 250 300	180 207 207 260	270 343 419 445	355 419 505 591	565 638 714	650 714	149 164 164	325 350 350	64 71 81	69 78 92

1) Bez. Motorbauart s. Kap. 3.  
 2) Nutzlänge des Gewindes 2 - F.  
 3) Werte gelten für Bremsmotor.  
 4) Bremsmotoren **F0 71D 4** und **F0 80D 4** nicht möglich.  
 5) Auf Anfrage und mit Mehrpreis, Maß P<sub>1</sub> = 160: bitte rückfragen.  
 6) Bauform **B5R**, Bremsmotor nicht möglich.  
 7) Auf Anfrage für 100LB 4, 112M 4 und 132M 4 auch Bauform **B5R** (s. Kap. 2b).  
 \* **WICHTIG:** bei **Bremsmotor** und Aufsteckbefestigung oder Bauformen V5, V6, **unbedingt rückfragen.**

1) For motor design see ch. 3.  
 2) Working length of thread 2 - F.  
 3) Values valid for brake motor.  
 4) Brake motors **F0 71D 4** and **F0 80D 4** not possible.  
 5) On request and with price addition, dimension P<sub>1</sub> = 160: consult us.  
 6) Mounting position **B5R**, brake motor not possible.  
 7) On request for 100LB 4, 112M 4 and 132M 4 also available mounting position **B5R** (see ch. 2b).  
 \* **IMPORTANT:** in the event of a **brake motor** and shaft mounting or mounting positions V5, V6, we **must be consulted.**

## Bauformen und Ölmengen [l]

## Mounting positions and oil quantities [l]

B3	B6	B7	B8	V5	V6	Größe Size	B3	B6, B7	B8	V5, V6
						40	0,26	0,26	0,35	0,3
						50	0,4	0,4	0,6	0,45
						63, 64	0,8	0,8	1	0,95
						80, 81	1,3	1,3	2	1,8
						100	2,6	2,9	3,8	3,5

Falls nicht anders angegeben, werden die Getriebemotoren in der normalen Bauform **B3** geliefert, die als solche **nicht** in der Bezeichnung aufzutreten braucht.

Unless otherwise stated, gearmotors are supplied in mounting position **B3** which, being standard, is **omitted** from the designation.

16 - Bauarten, Abmessungen, Bauformen und Ölmengen

16 - Designs, dimensions, mounting positions and oil quantities

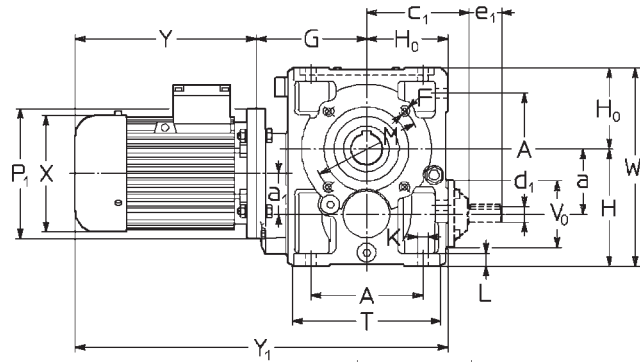

MR ICI 40 ... 200

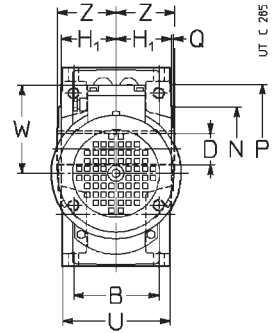

Bauart<sup>1)</sup> (Drehsinn)

Design<sup>1)</sup> (direction of rotation)

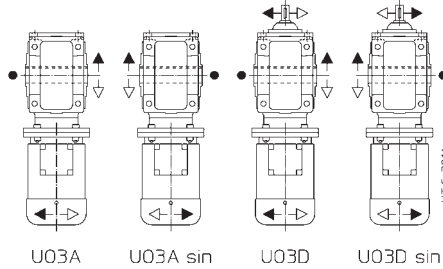

● Position der Bezugsrille (s. Kap. 20) zur Ermittlung der Radialbelastung.

● Position of the reference groove (see ch. 20) for verification of radial load.

Größe Size Getr. red.	Motor motor B5	a	A	c <sub>1</sub>	D Ø H7	d <sub>1</sub> Ø	e <sub>1</sub>	d <sub>1</sub> Ø	e <sub>1</sub> Ø	F	G	H h11	H <sub>0</sub> h11	H <sub>1</sub> h12	K Ø	L	M Ø	N Ø h6	P Ø	Q	T	V <sub>0</sub> Ø	Z	P <sub>1</sub> Ø	X Ø	Y	Y <sub>1</sub>	W	W <sub>1</sub>	Masse Mass kg			
		a <sub>1</sub>	B		i <sub>N</sub> ≤ 25	i <sub>N</sub> ≥ 31,5	2)	h11	h11	h12	Ø	Ø	h6	Ø	Ø	Ø	Ø	Ø	Ø	Ø	Ø	Ø	Ø	Ø	Ø	Ø	Ø	Ø	Ø	Ø	Ø		
40	63	41,5	73	74	19	11	23	11	23	M5	87	82	56	41,5	7	10	75	60	90	2,5	102	43	46	140	122	185	229	328	372	101	182	11	13
	71	40	65																		80			160	140	211	275	354	418	14	17		
50	63	50	86	94	24	16	30	14 <sup>6)</sup>	30 <sup>6)</sup>	M6	98	100	67	49	9,5	12	85	70	105	2,5	120	78	53	140	122	185	229	350	394	101	191	15	17
	71	40	75																		95			160	140	211	275	376	440	112	202	18	21
63	71	63	102	108	30	16	30	14 <sup>6)</sup>	30 <sup>6)</sup>	M8	118	125	80	58,5	11,5	14	100	80	120	3	143	78	63	160	140	211	275	409	473	112	224	23	26
	80	50	90		(63)																114			200	160	231	307	429	505	122	234	27	32
80	71	80	132	131	38	19	40	16 <sup>6)</sup>	30 <sup>6)</sup>	M10	138	150	100	69,5	14	17	130	110	160	3,5	180	86	75	160	140	211	275	449	513	112	250	35	38
	81	50	106		(80)																135			200	180	270	355	508	593	149	269	45	50
100	80	100	172	157	48	24	50	19 <sup>6)</sup>	40 <sup>6)</sup>	M12	170	180	125	84,5	16	20	165	130	200	3,5	228	104	90	200	160	231	307	526	602	122	305	60	65
	90	63	131		(81)																165			200	180	270	355	565	650	149	305	66	71
125	90	125	212	188	60	28	60	24 <sup>6)</sup>	50 <sup>6)</sup>	5)	205	225	150	103,5	18	23	215	180	250	4	274	122	110	200	180	270	355	625	710	149	375	105	110
	112	80	162																		201			250	207	343	445	698	800	164	375	112	119
140	90	140	212	188	70	28	60	24 <sup>6)</sup>	50 <sup>6)</sup>	5)	205	240	150	103,5	18	23	265	230	300	4	274	122	125	200	180	270	355	625	710	149	390	119	124
	112	80	162																		201			250	207	343	445	698	800	164	390	136	147
160	100	160	252	226	80	38	80	32 <sup>6)</sup>	80 <sup>6)</sup>	5)	247	280	180	128,5	22	28	265	230	300	4	328	155	136	250	207	343	445	770	872	164	460	185	192
	112	100	201																		249			300	260	402	537	829	964	196	460	195	206
180	112	180	252	226	90	38	80	32 <sup>6)</sup>	80 <sup>6)</sup>	5)	247	300	180	128,5	22	28	300	250	350	5	328	155	150	250	207	343	445	770	872	164	480	219	230
	132	100	201																		249			300	260	402	537	829	964	196	480	249	265
200	132	200	320	282	100	48	110	38 <sup>6)</sup>	80 <sup>6)</sup>	5)	305	355	225	158	27	34	350	300	400	5	410	190	167	300	260	402	537	932	1067	196	580	356	372
	160	125	250																		307			350	315	540	634	1070	1164	235	580	389	413
	200																							400	354	615	734	1145	1264	257	580	443	479
	225										315													450	416	690	—	1230	—	292	580	529	—

S. Anmerkungen auf Seite 121.

See notes on page 121.

Bauformen und Ölmengen [l]

Mounting positions and oil quantities [l]

B3	B6	B7	B8	V5	V6	Größe Size	B3, B7	B6	B8	V5, V6
						40	0,31	0,5	0,35	0,3
						50	0,45	0,8	0,65	0,5
						63, 64	1	1,6	1,2	1,15
						80, 81	1,6	2,7	2,2	2
						100	3	5,8	4,2	3,8
						125	6	11,6	9	7
						140	6,8	13,7	10,6	8,3
						160	10,6	21	16	13
						180	11,9	24,8	18,9	15,3
						200	20	40	30	24

Falls nicht anders angegeben, werden die Getriebemotoren in der normalen Bauform B3 geliefert, die als solche nicht in der Bezeichnung aufzutreten braucht.

Unless otherwise stated, gearmotors are supplied in mounting position B3 which, being standard, is omitted from the designation.



16 - Bauarten, Abmessungen, Bauformen und Ölmengen

16 - Designs, dimensions, mounting positions and oil quantities

MR C3I 50 ... 125

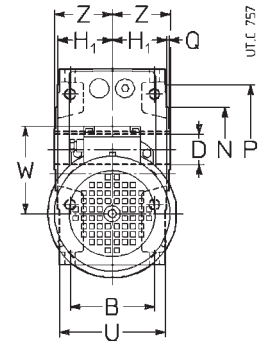
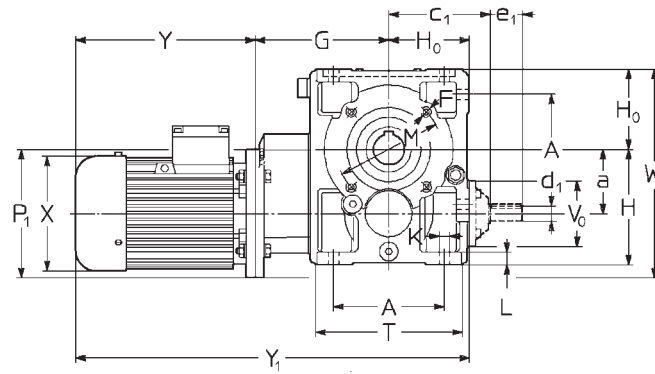

Bauart<sup>1)</sup> (Drehsinn)

Design<sup>1)</sup> (direction of rotation)

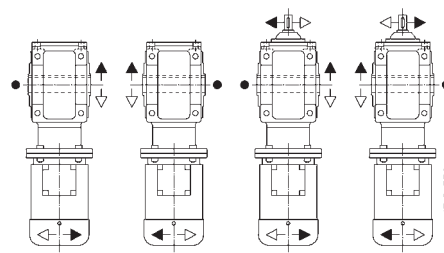

● Position der Bezugsrille (s. Kap. 20) zur Ermittlung der Radialbelastung.

● Position of the reference groove (see ch. 20) for verification of radial load.

Größe Size	a	A	c <sub>1</sub>	D Ø H7	d <sub>1</sub> Ø	e <sub>1</sub>	d <sub>0</sub> Ø	e <sub>1</sub>	F	G	H h11	H <sub>0</sub> h11	H <sub>1</sub> h12	K Ø	L	M	N h6	P Ø	Q	T	V <sub>0</sub> Ø	Z	P <sub>1</sub> Ø	X Ø ≈	Y ≈	Y <sub>1</sub> ≈	W ≈	W <sub>1</sub> ≈	Masse Mass kg			
																														Getr. red.	Motor motor	B
<b>50</b>	<b>63</b> <b>71</b>	50 86 75	94	24	16 <sup>4)</sup>	30 <sup>4)</sup>	14	30	M6	117	100	67	49	9,5	12	85	70	105	2,5	120	78	53	140	122	185	229	369	413	101	187	16	18
<b>63</b> <b>64</b>	<b>71</b> <b>80</b>	63 102 90	108	30 (63) 32 (64)	16 <sup>4)</sup>	30 <sup>4)</sup>	14	30	M8	145	125	80	58,5	11,5	14	100	80	120	3	143	78	63	160	140	211	275	436	500	112	223	24	27
<b>80</b> <b>81</b>	<b>71</b> <b>80</b>	80 132 106	131	38 (80) 40 (81)	19 <sup>4)</sup>	40 <sup>4)</sup>	16	30	M10	165	150	100	69,5	14	17	130	110	160	3,5	180	86	75	160	140	211	275	476	540	112	260	36	39
<b>100</b>	<b>80</b> <b>90</b>	100 172 131	157	48	24 <sup>4)</sup>	50 <sup>4)</sup>	19	40	M12	203	180	125	84,5	16	20	165	130	200	3,5	228	104	90	200	160	231	307	559	635	122	325	62	67
<b>125</b>	<b>90</b> <b>100</b> <b>112</b>	125 212 162	188	60	28 <sup>4)</sup>	60 <sup>4)</sup>	24	50	5)	249	225	150	103,5	18	23	215	180	250	4	274	122	110	200	180	270	355	669	754	149	375	108	113

- 1) Bez. Motorbauart s. Kap. 3.
- 2) Nutzlänge des Gewindes 2 · F.
- 3) Werte gelten für Bremsmotor.
- 4) Bei Getriebemotoren Größe 50 mit Motor 71, Größen 63, 64 mit Motor 80, Größe 81 mit Motor 80, Größe 100 mit Motor 90, Größe 125 mit Motoren 100, 112 und mit  $i_N = 125$ , s.  $d_1$  für  $i_N \geq 160$ .
- 5) Abmessung, Zahl und Winkelposition s. Kap. 20.
- 6) Für die Kombineinheiten - Getriebe 50 mit Motor 71, Getriebe 63 ... 81 mit Motor 80, Getriebe 100 mit Motor 90, Getriebe 125 mit Motor 100, 112, Getriebe 140 mit Motor 100, 112, 132, Getriebe 160 mit Motor 132, Getriebe 180 mit Motor 132 ... 180, Getriebe 200 mit Motor 160, 180 - mit  $i_N = 31,5$  (und  $i_N = 40$  für Getriebe 50 mit Motor 63, für Getriebe 140 mit Motor 112 und für Getriebe 180 mit Motor 132) s. Spalte  $i_N \leq 25$ .
- 7) Bei Bauform **B5R**, Größen 140 und 180 Bremsmotor nicht möglich.
- 8) Auf Anfrage und mit Mehrpreis, Maß  $P_1 = 160$ : bitte rückfragen.
- 9) Für Gruppen mit End -  $i_N = 31,5$  s. Spalte  $i_N \leq 25$ .

- 1) For motor design see ch. 3.
- 2) Working length of thread 2 · F.
- 3) Values valid for brake motor.
- 4) For gearmotors size 50 with motor 71, sizes 63, 64 with motor 80, size 80, 81 with motor 80, size 100 with motor 90, size 125 with motors 100, 112 and for gear red. 180 - having  $i_N = 31,5$  (and  $i_N = 40$  for gear red. 50 with motor 63, for gear red. 140 with motor 112 and for gear red. 180 with motor 132), see column  $i_N \leq 25$ .
- 5) For dimension, number and angular position see ch. 20.
- 6) For combinations - gear red. 50 with motor 71, gear red. 63 ... 81 with motor 80, gear red. 100 with motor 90, gear red. 125 with motors 100, 112, gear red. 140 with motor 100, 112, 132, gear red. 160 with motor 132, gear red. 180 with motor 132 ... 180, gear red. 200 with motor 160, 180 - having  $i_N = 31,5$  (and  $i_N = 40$  for gear red. 50 with motor 63, for gear red. 140 with motor 112 and for gear red. 180 with motor 132), see column  $i_N \leq 25$ .
- 7) Mounting position **B5R**, for gear red. 140 and 180 brake motor not possible.
- 8) On request and with price addition, dimension  $P_1 = 160$ : consult us.
- 9) For combined units with final  $i_N = 31,5$  see column  $i_N \leq 25$ .

Bauformen und Ölmengen [l]

Mounting positions and oil quantities [l]

Größe Size	B3, B7	B6	B8	V5, V6
<b>50</b>	0,5	0,9	0,7	0,55
<b>63, 64</b>	1,2	1,8	1,4	1,35
<b>80, 81</b>	1,9	3	2,5	2,3
<b>100</b>	3,3	6,3	4,5	4,1
<b>125</b>	6,4	12,8	9,5	7,5

Falls nicht anders angegeben, werden die Getriebemotoren in der normalen Bauform **B3** geliefert, die als solche **nicht** in der Bezeichnung aufzutreten braucht.

Unless otherwise stated, gearmotors are supplied in mounting position **B3** which, being standard, is **omitted** from the designation.

MR CI 125 ... 280

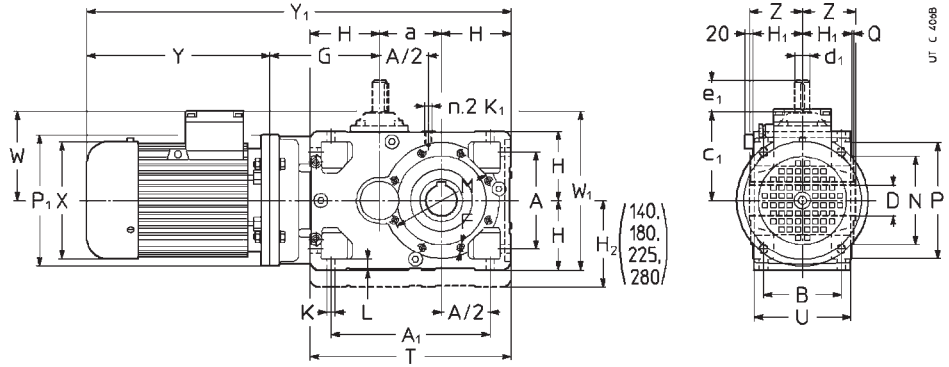

Bauart<sup>1)</sup> (Drehsinn)

Design<sup>1)</sup> (direction of rotation)

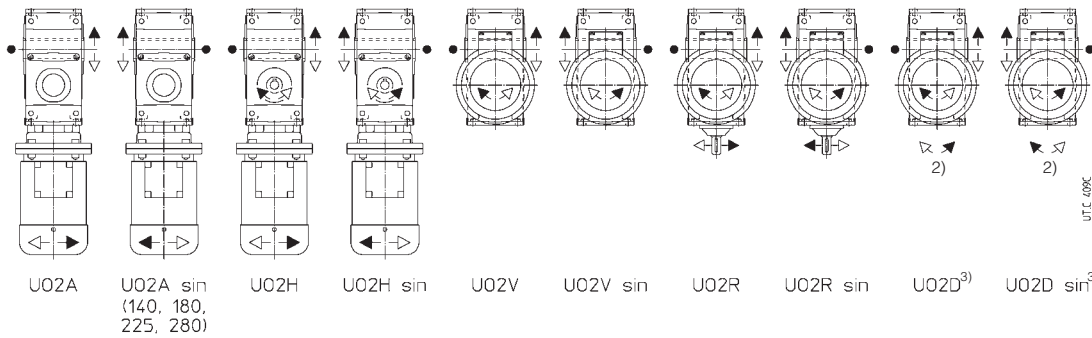

● Position der Bezugsgrille (s. Kap. 20) zur Ermittlung der Radialbelastung.

● Position of the reference groove (see ch. 20) for verification of radial load.

Größe Size	a	A	A <sub>1</sub>	c <sub>1</sub>	D Ø H7	d <sub>1</sub> Ø	e <sub>1</sub>	d <sub>2</sub> Ø	e <sub>2</sub>	F	G	H	H <sub>1</sub>	H <sub>2</sub>	K Ø	K <sub>1</sub>	M Ø	N Ø h6	P Ø	T	Z	P <sub>1</sub> Ø	X Ø ≈	Y ≈	Y <sub>1</sub> ≈	W ≈	W <sub>1</sub> ≈	Masse Mass kg				
																												6)	6)			
125	132 160 *180	125	212 162	337	188	60	28	60	24	50	7)	220 250	150	103,5	—	18 23	M12	215	180 4	250	425 201	110	300 350 350	260 315 354	402 540 615	537 634 734	897 1 065 1 140	1 032 1 159 1 259	196 235 257	346 410 432	159 192 246	175 216 282
140	132 160 180 <sup>9)</sup> 200 <sup>9)</sup>	140	212 162	352	188	70	28	60	24	50	7)	220 250	150	103,5	180	18 23	M12	265	230 4	300	440 201	125	300 350 350	260 315 354	402 540 615	537 634 734	912 1 080 1 155	1 047 1 174 1 274	196 235 257	376 440 462	172 205 259	188 229 295
160	160 180 200 225	160	252 201	412	226	80	38	80	32	80	M16	282	180	128,5	—	22 28	M16	265	230 4	300	520 249	136	350 350 400	315 354 354	540 615 615	634 734 734	1 162 1 237 1 237	1 256 1 356 1 356	235 257 257	415 437 457	261 315 341	285 351 381
180	180 200 225 250 <sup>9)</sup>	180	252 201	432	226	90	38	80	32	80	M16	282	180	128,5	225	22 28	M16	300	250 5	350	540 249	150	350 400 450	354 354 416	615 690 690	734 734 —	1 257 1 257 1 362	1 376 1 376 —	257 257 292	482 502 562	338 364 424	374 404 —
200	180 200 225 250 280	200	320 250	520	282	100	48	110	38	80	7)	325 355	225	158	—	27 34	M20	350	300 5	400	650 307	167	350 400 450 550	354 354 416 490	615 690 690 820	734 734 — —	1 365 1 365 1 470 1 470	1 484 1 484 — —	257 257 292 292	482 482 517 567	439 465 525 559	475 505 — —
225	225 250 280 315 <sup>9)</sup>	225	320 250	545	282	110	48	110	38	80	M20	355	225	158	280	27 34	M20	400	350 5	450	675 307	180	450 550 550 550	416 416 490 490	690 690 820 820	— — — —	1 495 1 495 1 625 1 625	— — — —	292 292 360 360	572 572 640 640	567 601 764 792	— — — —
250	225 250 280 315	250	396 310	646	357	125	55	110	48	110	7)	410 440	280	195	—	33 42	M24	500	450 5	550	810 380	206	450 550 550 660	416 416 490 604	690 690 820 962	— — — —	1 630 1 630 1 760 1 932	— — — —	292 292 360 445	572 572 640 775	798 772 939 1 254	— — — —
280	280 315	280	396 310	676	357	140	55	110	48	110	M24	410 440	280	195	355	33 42	M24	500	450 5	550	840 380	222	550 660	490 604	820 962	— —	1 790 1 962	— —	360 445	715 800	1 012 1 327	— —

1) Bez. Motorbauart s. Kap. 3.  
 2) Drehsinn des nicht gezeigten, vorstehenden schnelllaufenden Wellenendes.  
 3) **Nicht mögliche** Bauart für Größen 140, 180, 225 und 280.  
 4) Nutzlänge des Gewindes 2 · F.  
 5) Nutzlänge des Gewindes 2 · K<sub>1</sub>.  
 6) Werte gelten für Bremsmotor.  
 7) Abmessung, Zahl und Winkelposition s. Kap. 20.  
 8) Bremsmotor **FO 180L** nicht möglich.  
 9) Bei Bauform **B5R** (s. Kap. 2b), Bremsmotor nicht möglich.  
 \* **WICHTIG:** bei **Bremsmotor** und Aufsteckbefestigung **unbedingt rückfragen.**  
 Bremsmotor **FO 180L** nicht möglich.

1) For motor design see ch. 3.  
 2) Direction of rotation of high speed shaft extension not in view.  
 3) Design **not possible** for sizes 140, 180, 225 and 280.  
 4) Working length of thread 2 · F.  
 5) Working length of thread 2 · K<sub>1</sub>.  
 6) Values valid for brake motor.  
 7) For dimension, number and angular position see ch. 20.  
 8) Brake motors **FO 180L** not possible.  
 9) Mounting position **B5R** (see ch. 2b), brake motor not possible.  
 \* **IMPORTANT:** in the event of a **brake motor** and shaft mounting we **must be consulted.** Brake motor **FO 180L** not possible.

**Bauformen und Ölmengen [1]**

**Mounting positions and oil quantities [1]**

Bauart - Design	Bauform						Größe Size	Ölmengen				
	B3	B6	B7	B8	V5	V6		B3	B8	B7	B6, V5, V6	
UO2A UO2Asin UO2H UO2Hsin							125	4,25	5,6	6,3		
	140	6,8   4,8	7,8	8,8								
	160	8	10,6	11,8								
	180	12,8   9	14,8	16,5								
	200	15	20	22,4								
	225	24   17	28	31,5								
UO2V UO2Vsin UO2R UO2Rsin UO2D UO2Dsin							250	28	37,5	42,5		
	280	45   32	53	60								

Falls nicht anders angegeben, werden die Getriebemotoren in der normalen Bauform **B3** geliefert, die als solche **nicht** in der Bezeichnung aufzutreten braucht.  
 1) Position der Gewindebohrungen zur Bestimmung der Bauform.  
 2) Größen 140, 180, 225 und 280: Die Nennwärmeleistung  $P_{tN}$  (Kap. 4) ist mit **0,85** zu multiplizieren.  
 V ggf. hohe Ölspritzleistung: Die Nennwärmeleistung  $P_{tN}$  (Kap. 4) ist mit **0,85** zu multiplizieren.  
 O ggf. Lagerschmierpumpe: Bei Bedarf bitte rückfragen.

Unless otherwise stated, gearmotors are supplied in mounting position **B3** which, being standard, is **omitted** from the designation.  
 1) Position of tapped holes for identification of mounting position.  
 2) Sizes 140, 180, 225 and 280: nominal thermal power  $P_{tN}$  (ch. 4) is to be multiplied by **0,85**.  
 V possible high oil-splash: nominal thermal power  $P_{tN}$  (ch. 4) is to be multiplied by **0,85**.  
 O possible bearings lubrication pump: consult us if need be.

MR C2I 140 ... 360

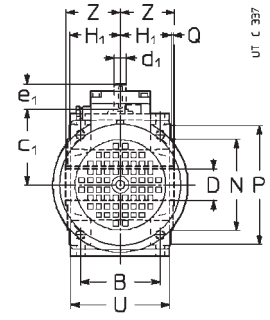
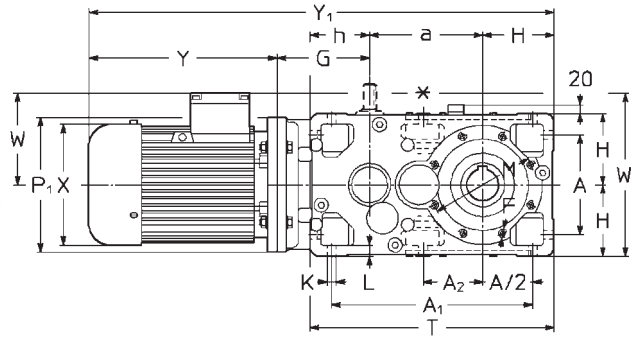

Bauart<sup>1)</sup> (Drehsinn)

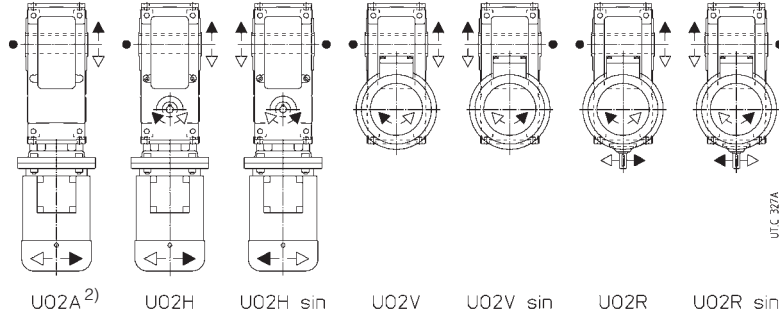

Design<sup>1)</sup> (direction of rotation)

● Position der Bezugsrille (s. Kap. 20) zur Ermittlung der Radialbelastung.

● Position of the reference groove (see ch. 20) for verification of radial load.

Größe Size	a	A	A <sub>1</sub>	A <sub>2</sub>	c <sub>1</sub>	D Ø H7	d <sub>1</sub> Ø	e <sub>1</sub>	d <sub>1</sub> Ø	e <sub>1</sub>	F	G	H	H <sub>1</sub>	h	K	L	M	N	P	T	Z	P <sub>1</sub> Ø	X Ø	Y	Y <sub>1</sub>	W	W <sub>1</sub>	Masse Mass kg		
																													4)	4)	
140	100 112 132 160 <sup>5)</sup>	240 212 162	427	127	157	70	24	50	19	40	7)	170	150	103,5	125	18	23	265	230	300	515	125	250 207 343 419	207 343 445	343 419	419 1033	903 979	164 314	142 149	152 163	
160	100 112 132 160 180	285 252 201	507	150*	188	80	28	60	24	50	M16	205	180	128,5	150	22	28	265	230	300	615	249	136	250 207 343 445	207 343 445	343 419	419 1013 1115	1089 1005	164 314	213 220	223 234
180	100 112 132 160 180 200 <sup>5)</sup>	305 252 201	527	170	188	90	28	60	24	50	M16	205	180	128,5	150	22	28	300	250	350	635	249	150	250 207 343 445	207 343 445	343 419	419 1033 1135	1109 1089	164 360	231 238	241 252
200	132 160 180 200 225	360 320 250	635	198*	226	100	38	80	32	80	7)	252 282	225	158	180	27	34	350	300	400	765	307	167	300 350 315 540 634	260 343 445	402 537	537 1239	1374 1501	196 450	392 408	425 449
225	132 160 180 200 225 250 <sup>5)</sup>	385 320 250	660	223	226	110	38	80	32	80	M20	252 282	225	158	180	27	34	400	350	450	790	307	180	300 350 315 540 634	260 343 445	402 537	537 1264 1432	1399 1526	196 450	423 439	456 480
250	160 180 200 225 250 280	450 396 310	791	247*	282	125	48	110	38	80	7)	325	280	195	225	33	42	500	450	550	955	380	206	350 315 540 634	315 540 634	634 1670	1670 1789	1595 1689	235 560	667 691	721 745
280	160 180 200 225 250 280 315 <sup>5)</sup>	480 396 310	821	277	282	140	48	110	38	80	M24	325	280	195	225	33	42	500	450	550	985	380	222	350 315 540 634	315 540 634	634 1700	1700 1819	1625 1719	235 560	721 745	811 841
320	200 225 250 280 315	570 510 386	1005	318*	357	160	55	110	48	110	7)	380 410	355	241	280	39	52	600	550	660	1205	470	254	400 354 615 734	354 615 734	615 734	734 1920	2039 2025	257 710	1175 1215	1235 1269
360	200 225 250 280 315	610 510 386	1045	358	357	180	55	110	48	110	M30	380 410	355	241	280	39	52	600	550	660	1245	470	273	400 354 615 734	354 615 734	615 734	734 1960	2079 2065	257 710	1270 1310	1364 1432

\* Nur Nr. 2 Bohrungen M 16 × 32 (Gr. 160), M 20 × 38 (Gr. 200), M 24 × 46 (Gr. 250) und M 30 × 58 (Gr. 320) und nicht für Bauart U02A.

\* No. 2 holes only M 16 × 32 (size 160), M 20 × 38 (size 200), M 24 × 46 (size 250) and M 30 × 58 (size 320) except U02A design.

1) Bez. Motorbauart s. Kap. 3.  
 2) Das Gehäuse dieser Bauart ist nicht für andere Bauarten geeignet.  
 3) Nutzlänge des Gewindes 2 · F.  
 4) Werte gültig für Bremsmotor.  
 5) Bauform B5R (s. Kap. 2b), Bremsmotor nicht möglich.  
 6) Bei Bauarten ...V...V sin...R...R sin, Gr. 140 ... 225, Maß G erhöht um 10 mm.  
 7) Abmessung, Zahl und Winkelposition s. Kap. 20.

1) For motor design see ch. 3.  
 2) The casing of this design is not prearranged for other designs.  
 3) Working length of thread 2 · F.  
 4) Values valid for brake motor.  
 5) Mounting position B5R (see ch. 2b), brake motor not possible.  
 6) For designs ...V...V sin...R...R sin, sizes 140 ... 225, dimension G increases by 10 mm.  
 7) For dimension, number and angular position see ch. 20.

**Bauformen und Ölmengen [1]**

**Mounting positions and oil quantities [1]**

	B3	B6	B7	B8	V5	V6	Grand. Size	B3,B8	B6	B7, V5, V6						
Ejecución - Execution UO2A UO2H UO2Hsin		$\psi \geq 160$ $UO2Hsin \geq 160$	$\psi \geq 320$	$\psi \geq 250$ , ● in alto - above	1)	1)	140	6	10,6	9,5						
							160	10	18	16						
							180	10,6	19	17						
							200	19	34	30						
							225	20	36	32						
							250	36	63	56						
UO2V UO2Vsin UO2R UO2Rsin		$\psi \geq 160$ $UO2Rsin \geq 160$	$\psi \geq 320$	$\psi \geq 250$ , ● in alto - above	1)	1)	280	38	67	60						
							320	67	118	106						
							360	71	126	112						
											U.T.C 344A					

Falls nicht anders angegeben, werden die Getriebemotoren in der normalen Bauform **B3** geliefert, die als solche **nicht** in der Bezeichnung aufzutreten braucht.  
 1) Position der Zwischenbohrung zur Bestimmung der Bauform.  
 $\psi$  ggf. hohe Ölspritzleistung: Die Nennwärmeleistung  $P_{N1}$  (Kap. 4) ist mit **0,85** zu multiplizieren.  
 $\psi$  ggf. Lagerschmierpumpe. Bei Bedarf bitte rückfragen.

Unless otherwise stated, gearmotors are supplied in mounting position **B3** which, being standard, is **omitted** from the designation.  
 1) Position of intermediate hole for identification of mounting position.  
 $\psi$  possible high oil-splash: nominal thermal power  $P_{N1}$  (ch. 4) is to be multiplied by **0,85**;  
 $\psi$  possible bearings lubrication pump: consult us if need be.

**17 - Kombieinheiten Getriebemotoren**  
**Nenn Drehmomente der Auslaufgetriebe und**  
**Kombieinheitentypen (Stirnradgetriebemotoren)**

**17 - Combined gearmotor units**  
**Nominal torques for final gear reducer and types of**  
**combined units (parallel shafts)**

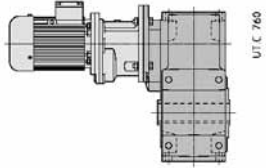
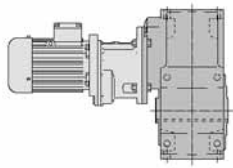
$M_{N2}$ [daN m] bei for $n_2 \leq 14 \text{ min}^{-1}$ <sup>4)</sup>	MR 2I + MR 2I, 3I	MR 3I + MR 2I, 3I	MR 3I + MR 2I, 3I
		$i_N \approx 80 \dots 2\,500$ $\eta_{\text{Auslauf}}^{\text{final}} 0,96$	
<b>31,5</b>	MR 2I 63-80B 4 ... B5A/72,6 <sup>1)</sup> + MR 2I, 3I 40 $i_{\text{Auslauf}}^{\text{final}} = 19,3$	MR 3I 63-71B 4 ... B5A/28,6 <sup>2)</sup> + MR 2I, 3I 32 $i_{\text{Auslauf}}^{\text{final}} = 48,9$ Bauart: Wellenende Ø 14 design: shaft end Ø 14	
<b>38,7</b>	MR 2I 64-80B 4 ... B5A/69,7 <sup>1)</sup> + MR 2I, 3I 40 $i_{\text{Auslauf}}^{\text{final}} = 20,1$	MR 3I 64-71B 4 ... B5A/27,5 <sup>2)</sup> + MR 2I, 3I 32 $i_{\text{Auslauf}}^{\text{final}} = 50,9$ Bauart: Wellenende Ø 14 design: shaft end Ø 14	
<b>67</b>	MR 2I 80-80B 4 ... B5A/67,2 <sup>1)</sup> + MR 2I, 3I 40 $i_{\text{Auslauf}}^{\text{final}} = 20,8$	MR 3I 80-80B 4 ... B5A/26,5 <sup>1)</sup> + MR 2I, 3I 40 $i_{\text{Auslauf}}^{\text{final}} = 52,9$	
<b>78</b>	MR 2I 81-80B 4 ... B5A/67,2 <sup>1)</sup> + MR 2I, 3I 40 $i_{\text{Auslauf}}^{\text{final}} = 20,8$	MR 3I 81-80B 4 ... B5A/26,5 <sup>1)</sup> + MR 2I, 3I 40 $i_{\text{Auslauf}}^{\text{final}} = 52,9$	
<b>140</b>	MR 2I 100-90LB 4 ... B5/72,5 + MR 2I, 3I 50 <sup>3)</sup> $i_{\text{Auslauf}}^{\text{final}} = 19,3$	MR 3I 100-90L 4 ... B5/28,6 + MR 2I, 3I 50 <sup>3)</sup> $i_{\text{Auslauf}}^{\text{final}} = 49$	
<b>280</b>	MR 2I 125-112M 4 ... B5/72,5 + MR 2I, 3I 63 <sup>3)</sup> $i_{\text{Auslauf}}^{\text{final}} = 19,3$	MR 3I 125-90LB 4 ... B5/23,2 + MR 2I, 3I 50 <sup>3)</sup> $i_{\text{Auslauf}}^{\text{final}} = 60,2$	
<b>412</b>			MR 3I 140-112M 4 ... B5/27,8 + MR 2I, 3I 63 <sup>3)</sup> $i_{\text{Auslauf}}^{\text{final}} = 50,4$
<b>615</b>			MR 3I 160-132M 4 ... B5/44,3 + MR 2I 80 <sup>3)</sup> $i_{\text{Auslauf}}^{\text{final}} = 31,6$ MR 3I 160-112M 4 ... B5/13,1 + MR 2I, 3I 63 <sup>3)</sup> $i_{\text{Auslauf}}^{\text{final}} = 107$ bei $n_2 \leq 2,8 \text{ min}^{-1}$
<b>875</b>			MR 3I 180-132MB 4 ... B5/27,4 + MR 2I 80 <sup>3)</sup> $i_{\text{Auslauf}}^{\text{final}} = 51$ MR 3I 180-112M 4 ... B5/13 + MR 2I, 3I 63 <sup>3)</sup> $i_{\text{Auslauf}}^{\text{final}} = 108$ bei $n_2 \leq 2,8 \text{ min}^{-1}$
<b>1 250</b>			MR 3I 200-180L 4 ... B5/44,5 + MR 2I 100 <sup>3)</sup> $i_{\text{Auslauf}}^{\text{final}} = 31,5$ MR 3I 200-132M 4 ... B5/14 + MR 2I, 3I 80 <sup>3)</sup> $i_{\text{Auslauf}}^{\text{final}} = 100$ bei $n_2 \leq 2,8 \text{ min}^{-1}$
<b>1 750</b>			MR 3I 225-180L 4 ... B5/27 + MR 2I 100 <sup>3)</sup> $i_{\text{Auslauf}}^{\text{final}} = 51,8$ MR 3I 225-132MC 4 ... B5/14,2 + MR 2I, 3I 80 <sup>3)</sup> $i_{\text{Auslauf}}^{\text{final}} = 98,5$ bei $n_2 \leq 2,8 \text{ min}^{-1}$
<b>2 500</b>			MR 3I 250-225M 4 ... B5/41,7 + MR 2I 125 <sup>3)</sup> $i_{\text{Auslauf}}^{\text{final}} = 33,5$ MR 3I 250-180L 4 ... B5/14,2 + MR 2I, 3I 100 <sup>3)</sup> $i_{\text{Auslauf}}^{\text{final}} = 98,5$ bei $n_2 \leq 2,8 \text{ min}^{-1}$
<b>3 450</b>			MR 3I 280-225M 4 ... B5/26,6 + MR 2I 125 <sup>3)</sup> $i_{\text{Auslauf}}^{\text{final}} = 52,7$ MR 3I 280-180L 4 ... B5/14 + MR 2I, 3I 100 <sup>3)</sup> $i_{\text{Auslauf}}^{\text{final}} = 100$ bei $n_2 \leq 2,8 \text{ min}^{-1}$
<b>4 370</b>			MR 3I 320-225M 4 ... B5/20,9 + MR 2I 125 <sup>3)</sup> $i_{\text{Auslauf}}^{\text{final}} = 67,1$ MR 3I 320-225M 4 ... B5/13,4 + MR 2I, 3I 125 <sup>3)</sup> $i_{\text{Auslauf}}^{\text{final}} = 105$ bei $n_2 \leq 2,8 \text{ min}^{-1}$
<b>5 300</b>			MR 3I 321-225M 4 ... B5/20,9 + MR 2I 125 <sup>3)</sup> $i_{\text{Auslauf}}^{\text{final}} = 67,1$ MR 3I 321-225M 4 ... B5/13,4 + MR 2I, 3I 125 <sup>3)</sup> $i_{\text{Auslauf}}^{\text{final}} = 105$ bei $n_2 \leq 2,8 \text{ min}^{-1}$
<b>6 900</b>			MR 3I 360-225M 4 ... B5/13,6 + MR 2I, 3I 125 <sup>3)</sup> $i_{\text{Auslauf}}^{\text{final}} = 103$

Leistungen und Abmessungen des Einlaufgetriebemotors: Katalog E Kap. 8, 9 und 10.  
 1, 2) Der Auslaufgetriebemotor hat einen 160<sup>1)</sup> oder 140<sup>2)</sup> Befestigungsflansch (Maß P, Kap. 13).  
 3) Getriebemotor mit Ausführung «Überdimensionierter B5-Flansch»; Größe 63 hat eine langsamlaufende Welle bei 28 mm: «Überdimensionierter B5-Flansch - Ø 28».  
 4) Der angefragte Betriebsfaktor kann um **1,06** bei  $n_2 = 2,8 \div 0,71 \text{ min}^{-1}$ , **1,12** bei  $n_2 \leq 0,71 \text{ min}^{-1}$ , reduziert werden, vorausgesetzt dass  $f_s$  immer  $\geq 0,8$  ist.

Initial gearmotor dimensions and performance data see cat. E, ch. 8, 9 and 10.  
 1, 2) Final gearmotor has 160<sup>1)</sup> or 140<sup>2)</sup> motor-mounting flange (see dimension P, ch. 13).  
 3) Gearmotor in design «Oversized B5 flange»; more over, size 63 has the low speed shaft reduced to 28 mm: «Oversized B5 flange - Ø 28».  
 4) Provided that  $f_s$  is always  $\geq 0,8$ , it can be reduced by **1,06** for  $n_2 = 2,8 \div 0,71 \text{ min}^{-1}$ , by **1,12** for  $n_2 \leq 0,71 \text{ min}^{-1}$ .

17 - Kombieinheiten Getriebemotoren  
**Nenn Drehmomente der Auslaufgetriebe und Kombieinheitentypen (Kegelstirnradgetriebemotoren)**

17 - Combined gearmotor units  
**Nominal torques for final gear reducer and types of combined units (right angle shafts)**

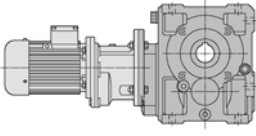
$M_{N2}$ [daN m] bei for $n_2 \leq 14 \text{ min}^{-1}$ <sup>4)</sup>	MR ICI + MR 2I, 3I	MR C2I + MR 2I, 3I
		 $i_N \approx 125 \dots 8\,000$ $\eta_{\text{Auslauf}} = 0,94$
31,5	<b>MR ICI 63-80B 4 ... B5A/43,7<sup>1)</sup></b> + MR 2I, 3I 40 $i_{\text{Auslauf}} = 32$	
38,7	<b>MR ICI 64-80B 4 ... B5A/43,7<sup>1)</sup></b> + MR 2I, 3I 40 $i_{\text{Auslauf}} = 32$	
67	<b>MR ICI 80-80B 4 ... B5A/42<sup>1)</sup></b> + MR 2I, 3I 40 $i_{\text{Auslauf}} = 33,4$	
78	<b>MR ICI 81-80B 4 ... B5A/42<sup>1)</sup></b> + MR 2I, 3I 40 $i_{\text{Auslauf}} = 33,4$	
140	<b>MR ICI 100-90LC 4 ... B5/44,6</b> + MR 2I, 3I 50 <sup>3)</sup> $i_{\text{Auslauf}} = 31,4$	
280	<b>MR ICI 125-112M 4 ... B5/43,8</b> + MR 2I, 3I 63 <sup>3)</sup> $i_{\text{Auslauf}} = 32$ <b>MR ICI 125-90LB 4 ... B5/22,4</b> + MR 2I, 3I 50 <sup>3)</sup> $i_{\text{Auslauf}} = 62,5$ bei $M_{N2} \leq 243 \text{ daN m}$	
412	<b>MR ICI 140-112M 4 ... B5/35</b> + MR 2I, 3I 63 <sup>3)</sup> $i_{\text{Auslauf}} = 40$ bei $M_{N2} \leq 355 \text{ daN m}$	<b>MR C2I 140-112M 4 ... B5/27,8</b> + MR 2I, 3I 63 <sup>3)</sup> $i_{\text{Auslauf}} = 50,4$
615	<b>MR ICI 160-132M 4 ... B5/42</b> + MR 2I, 3I 80 <sup>3)</sup> $i_{\text{Auslauf}} = 33,3$ <b>MR ICI 160-112M 4 ... B5/22,4</b> + MR 2I, 3I 63 <sup>3)</sup> $i_{\text{Auslauf}} = 62,5$ bei $M_{N2} \leq 530 \text{ daN m}$	<b>MR C2I 160-132MB 4 ... B5/43,1</b> + MR 2I 80 <sup>3)</sup> $i_{\text{Auslauf}} = 32,5$ <b>MR C2I 160-112M 4 ... B5/13,5</b> + MR 2I, 3I 63 <sup>3)</sup> $i_{\text{Auslauf}} = 103$ bei $n_2 \leq 2,8 \text{ min}^{-1}$
875	<b>MR ICI 180-132M 4 ... B5/34,3</b> + MR 2I, 3I 80 <sup>3)</sup> $i_{\text{Auslauf}} = 40,9$ bei $M_{N2} \leq 750 \text{ daN m}$	<b>MR C2I 180-132MB 4 ... B5/26,7</b> + MR 2I 80 <sup>3)</sup> $i_{\text{Auslauf}} = 52,4$ <b>MR C2I 180-112M 4 ... B5/13,5</b> + MR 2I, 3I 63 <sup>3)</sup> $i_{\text{Auslauf}} = 104$ bei $n_2 \leq 2,8 \text{ min}^{-1}$
1250	<b>MR ICI 200-180L 4 ... B5/42</b> + MR 2I, 3I 100 <sup>3)</sup> $i_{\text{Auslauf}} = 33,3$ <b>MR ICI 200-132MB 4 ... B5/22,4</b> + MR 2I, 3I 80 <sup>3)</sup> $i_{\text{Auslauf}} = 62,5$ bei $M_{N2} \leq 1\,090 \text{ daN m}$	<b>MR C2I 200-180L 4 ... B5/43,4</b> + MR 2I 100 <sup>3)</sup> $i_{\text{Auslauf}} = 32,3$ <b>MR C2I 200-132M 4 ... B5/13,8</b> + MR 2I, 3I 80 <sup>3)</sup> $i_{\text{Auslauf}} = 102$ bei $n_2 \leq 2,8 \text{ min}^{-1}$
1750		<b>MR C2I 225-180L 4 ... B5/26,4</b> + MR 2I 100 <sup>3)</sup> $i_{\text{Auslauf}} = 53,1$ <b>MR C2I 225-132M 4 ... B5/14</b> + MR 2I, 3I 80 <sup>3)</sup> $i_{\text{Auslauf}} = 100$ bei $n_2 \leq 2,8 \text{ min}^{-1}$
2500		<b>MR C2I 250-225M 4 ... B5/41,4</b> + MR 2I 125 <sup>3)</sup> $i_{\text{Auslauf}} = 33,9$ <b>MR C2I 250-180L 4 ... B5/14,2</b> + MR 2I, 3I 100 <sup>3)</sup> $i_{\text{Auslauf}} = 98,5$ bei $n_2 \leq 2,8 \text{ min}^{-1}$
3450		<b>MR C2I 280-225M 4 ... B5/26,3</b> + MR 2I 125 <sup>3)</sup> $i_{\text{Auslauf}} = 53,1$ <b>MR C2I 280-180L 4 ... B5/14</b> + MR 2I, 3I 100 <sup>3)</sup> $i_{\text{Auslauf}} = 100$ bei $n_2 \leq 2,8 \text{ min}^{-1}$
4370		<b>MR C2I 320-225M 4 ... B5/21,5</b> + MR 2I 125 <sup>3)</sup> $i_{\text{Auslauf}} = 65,1$ <b>MR C2I 320-225M 4 ... B5/13,6</b> + MR 2I, 3I 125 <sup>3)</sup> $i_{\text{Auslauf}} = 103$ bei $n_2 \leq 2,8 \text{ min}^{-1}$
5300		<b>MR C2I 321-225M 4 ... B5/21,5</b> + MR 2I 125 <sup>3)</sup> $i_{\text{Auslauf}} = 65,1$ <b>MR C2I 321-225M 4 ... B5/13,6</b> + MR 2I, 3I 125 <sup>3)</sup> $i_{\text{Auslauf}} = 103$ bei $n_2 \leq 2,8 \text{ min}^{-1}$
6900		<b>MR C2I 360-225M 4 ... B5/13,8</b> + MR 2I, 3I 125 <sup>3)</sup> $i_{\text{Auslauf}} = 102$

Leistungen und Abmessungen des Einlaufgetriebemotors: Katalog E Kap. 8, 9 und 10.  
 1) Der Auslaufgetriebemotor hat einen 160 mm Befestigungsflansch (Maß P<sub>1</sub>, Kap. 16).  
 3) Der Einlaufgetriebemotor Größe  $\geq 50$  mit Ausführung «Überdimensionierter B5-Flansch»; die Größe 63 hat eine langsamlaufende Welle, die zu 28 mm reduziert ist: «Überdimensionierter B5-Flansch - Ø 28».  
 4) Der angefragte Betriebsfaktor kann um **1,06** bei  $n_2 = 2,8 \div 0,71 \text{ min}^{-1}$ , **1,12** bei  $n_2 \leq 0,71 \text{ min}^{-1}$ , reduziert werden, vorausgesetzt dass  $f_s$  immer  $\geq 0,8$  ist.

Initial gearmotor dimensions and performance data see cat. E, ch. 8, 9 and 10.  
 1) Final gearmotor has a 160 mm motor-mounting flange (see dimension P<sub>1</sub>, ch. 16).  
 3) Initial gearmotor size  $\geq 50$  in design «Oversized B5 flange»; moreover, size 63 has the low speed shaft reduced to 28 mm: «Oversized B5 flange - Ø 28».  
 4) Provided that  $f_s$  is always  $\geq 0,8$ , it can be reduced by **1,06** for  $n_2 = 2,8 \div 0,71 \text{ min}^{-1}$ , by **1,12** for  $n_2 \leq 0,71 \text{ min}^{-1}$ .

**Bauform des Einlaufgetriebes**

Um die Bestimmung der Bauform der Getriebemotorkombieinheiten zu vereinfachen, bitte folgende Tabelle in Betrachtung nehmen, wo in Bezug auf Typ, Bauform und Auslaufgetriebe die Bauformen des Einlaufgetriebemotors angegeben sind.

**Initial gearmotor mounting position**

In order to make easier the individualization of the combined gearmotors mounting position refer to the following table where, according to the type, to the mounting position and to the final gear reducer, the mounting positions of the initial gearmotor are stated.

Bauform des **Einlaufgetriebemotors**

Initial **gearmotor** mounting position

Paarungsform Coupling position	Bauform des Auslaufgetriebes - Final gear reducer mounting position					
	B3	B6	B7	B8	V5	V6
MR 2I 63 ... 125 + MR 2I, 3I	B5* ≤40 <sup>1)</sup> B7 ≥50 	B5* =40 B3* ≥50 	B5* =40 B3* ≥50 	B5* =40 <sup>1)</sup> B6 ≥50 	V1 =40 V5 ≥50 	V3 =40 V6 ≥50 
MR 3I 63 ... 125 + MR 2I, 3I	B5* ≤40 <sup>1)</sup> B7 ≥50 	B5* ≤40 B3* ≥50 	B5* ≤40 B3* ≥50 	B5* ≤40 <sup>1)</sup> B6 ≥50 	V1 ≤40 V5 ≥50 	V3 ≤40 V6 ≥50 
MR 3I 140 ... 360 + MR 2I, 3I	B7 	B3* 	B3* 	B6 	V5 	V6 
MR ICI 63 ... 200 + MR 2I, 3I	B5* ≤40 B3* ≥50 	V1 ≤40 V5 ≥50 	V3 ≤40 V6 ≥50 	B5* ≤40 B3* ≥50 	B5* ≤40 <sup>1)</sup> B6 ≥50 	B5* ≤40 <sup>1)</sup> B7 ≥50 
MR C2I 140 ... 360 + MR 2I, 3I	B3* 	V5 	V6 	B3* 	B7 	B6 

\* Als normal braucht diese Bauform **nicht** in der Bezeichnung aufzutreten.  
1) Fettquantität entspricht derjenigen der Bauform B3, s. Kat. E.  
Auf dem Typenschild ist ein \* im Bauformraum angegeben.

\* This mounting position, being standard, must **not** be stated in the designation.  
1) Grease quantity is the same foreseen for B3 mounting position in cat. E.  
On name plate there is a \* in correspondence of mounting position.





## 18 - Radialbelastungen<sup>1)</sup> $F_{r1}$ [daN] auf dem schnelllaufenden Wellenende

Wenn die Verbindung zwischen Motor und Getriebe durch einen Antrieb erfolgt, welcher Radialbelastungen auf dem Wellenende bewirkt, muss es nachgeprüft werden, dass diese Belastungen die in der Tabelle angegebenen Werte nicht überschreiten. Bei den üblichen Antriebsfällen ist die Radialbelastung  $F_{r1}$  nach folgender Formel berechnet:

$$F_{r1} = \frac{2\,865 \cdot P_1}{d \cdot n_1} \text{ [daN]} \quad \text{für Zahnriementrieb}$$

$$F_{r1} = \frac{4\,775 \cdot P_1}{d \cdot n_1} \text{ [daN]} \quad \text{für Keilriementrieb}$$

wobei:  $P_1$  [kW] die an der Getriebeantriebswelle erforderliche Leistung,  $n_1$  [min<sup>-1</sup>] die Drehzahl,  $d$  [m] der Teilkreisdurchmesser ist.

Die in der Tabelle angegebenen zulässigen Radialbelastungen gelten für Belastungen, die in der Mittellinie des schnelllaufenden Wellenendes auf einem Abstand von  $0,5 \cdot e$  ( $e$  = Länge des Wellenendes) vom Wellenabsatz angreifen. Liegt der Angriffspunkt bei  $0,315 \cdot e$  die Tabellenwerte mit  $1,25$  multiplizieren; liegt der Angriffspunkt bei  $0,8 \cdot e$ , die Tabellenwerte mit  $0,8$  multiplizieren.

Es ist empfohlen, dass die **Scheibe immer am Anschlag** montiert ist und dass sie aus Wellenende vorsteht.

## 18 - Radial loads<sup>1)</sup> $F_{r1}$ [daN] on high speed shaft end

Radial loads generated on the shaft end by a drive connecting gear reducer and motor must be less than or equal to those given in the relevant table.

The radial load  $F_{r1}$  given by the following formula refers to most common drives:

$$F_{r1} = \frac{2\,865 \cdot P_1}{d \cdot n_1} \text{ [daN]} \quad \text{for timing belt drive}$$

$$F_{r1} = \frac{4\,775 \cdot P_1}{d \cdot n_1} \text{ [daN]} \quad \text{for V-belt drive}$$

where:  $P_1$  [kW] is power required at the input side of the gear reducer,  $n_1$  [min<sup>-1</sup>] is the speed,  $d$  [m] is the pitch diameter.

Radial loads given in the table are valid for overhung loads on centre line of high speed shaft end, i.e. operating at a distance of  $0,5 \cdot e$  ( $e$  = shaft end length) from the shoulder. If they operate at  $0,315 \cdot e$  multiply by  $1,25$ ; if they operate at  $0,8 \cdot e$  multiply by  $0,8$ .

It is always advisable **to mount the pulley against the shaft shoulder** and in any case to avoid that the pulley exceeds the shaft end.

$n_1$ min <sup>-1</sup>	Getriebegröße Gear reducer size																																		
	50				63, 64				80, 81			100				125, 140					160, 180				200, 225				250, 280			320 ... 360			
	R 2l	R 1	R 2l	R 1	R 2l	R 1	R 2l	R 1	R 2l	R 1	R 2l	R 1	R 2l	R 1	R 2l	R 1	R 2l	R 1	R 2l	R 1	R 2l	R 1	R 2l	R 1	R 2l	R 1	R 2l	R 1	R 2l	R 1	R 2l	R 1	R 2l	R 1	R 2l
1 400	33,5	17	85	53	17	26,5	132	85	42,5	212	132	67	42,5	335	212	132	106	67	530	335	212	170	850	530	335	265	1320	850	530	2120	1320	850			
1 120	35,5	18	90	56	18	28	140	90	45	224	140	71	45	355	224	140	112	71	560	355	224	180	900	560	355	280	1400	900	560	2240	1400	900			
900	37,5	19	95	60	19	30	150	95	47,5	236	150	75	47,5	375	236	150	118	75	600	375	236	190	950	600	375	300	1500	950	600	2360	1500	950			
710	42,5	21,2	106	67	21,2	33,5	170	106	53	265	170	85	53	425	265	170	132	85	670	425	265	212	1060	670	425	335	1700	1060	670	2650	1700	1060			
560	45	22,4	112	71	22,4	35,5	180	112	56	280	180	90	56	450	280	180	140	90	710	450	280	224	1120	710	450	355	1800	1120	710	2800	1800	1120			
450	47,5	23,6	118	75	23,6	37,5	190	118	60	300	190	95	60	475	300	190	150	95	750	475	300	236	1180	750	475	375	1900	1180	750	3000	1900	1180			
355	53	26,5	132	85	26,5	42,5	212	132	67	335	212	106	67	530	335	212	170	106	850	530	335	265	1320	850	530	425	2120	1320	850	3350	2120	1320			

1) Außer der Radialbelastung kann gleichzeitig eine Axialbelastung vorliegen, die das 0,2-fache der Tabellenwerte erreichen kann. Bei höheren Werten bitte rückfragen.

2) Werte gelten nur für Größe 140.

1) An axial load of up to 0,2 times the value in the table is permissible, simultaneously with the radial load. If exceeded consult us.

2) Values valid for size 140 only.

**WICHTIG:** Die auf den Drehsinn, die Lastwinkellage, usw. bezogenen Radialbelastungen  $F_{r1}$ , können die Tabellenwerte um ein Mehrfaches übersteigen. Bei Bedarf bitte **rückfragen**.

**IMPORTANT:** tabulated values for radial load  $F_{r1}$  can increase considerably in certain instances (direction of rotation, angular position of load, etc.). **Consult us** if need be.

## 19 - Radial- $F_{r2}$ [daN] oder Axialbelastungen $F_{a2}$ [daN] auf dem langsamlaufenden Wellenende

### Axialbelastungen $F_{a2}$

Den zugelassenen  $F_{a2}$ -Wert entnimmt man der Spalte, in der Drehsinn der langsamlaufenden Welle (weißer oder schwarzer Pfeil) und Richtung der Axialkraft (durchgehender oder gestrichelter Pfeil) denjenigen Werten entsprechen, die auf dem Getriebe angeführt sind. Die Bestimmung des Drehsinns und der Kraftrichtung kann von einem beliebigen Punkt aus durchgeführt werden, sofern er sowohl für die Drehung wie auch für die Kraft derselbe ist.

Wenn möglich, beziehen Sie sich auf die Belastungsbedingungen, die der **Spalte** mit den **höchsten** Werten entsprechen.

### Radialbelastungen $F_{r2}$

Wenn die Verbindung zwischen Getriebe und Arbeitsmaschine durch einen Antrieb erfolgt, welcher Radialbelastungen auf dem Wellenende bewirkt, muss es nachgeprüft werden, dass diese Belastungen die in der Tabelle angegebenen Werte nicht überschreiten.

Normalerweise ist die Radialbelastung des langsamlaufenden Wellenendes erheblich, weil man dazu neigt, die Übertragungselemente zwischen Getriebe und Arbeitsmaschine mit einer hohen Untersetzung (Getriebe wird dadurch preisgünstiger) und mit kleinem Durchmesser (Übertragungselemente werden preisgünstiger oder Platzbedarf ist geringer) auszuführen. Die Lebensdauer und der Verschleiß der Lager (was auch die Radpaare negativ beeinflusst), sowie die Festigkeit der langsamlaufenden Welle setzen der zulässigen Radialbelastung natürlich bestimmte Grenzen.

Durch die hohe erreichbare Radialbelastung und die nicht zu überschreitenden zulässigen Werte ist die vom Getriebe gebotene Leistung maximal auszunützen. Die in der Tabelle angegebenen zulässigen Radialbelastungen hängen von fig. Kenngrößen ab: Von der langsamlaufenden Wellenseite der Radialbelastungen im Verhältnis zur Bezugsrille (s. Kap. 20 und Kap. 8, 10, 13, 16), vom Produkt aus der Drehzahl  $n_2$  [min<sup>-1</sup>] und der gewünschten Lebensdauer  $L_h$  [h] der Lager, von der Drehrichtung, von der Winkellage  $\varphi$  [°] der Belastung und vom gewünschten Drehmoment  $M_2$  [daN m].

Die in der Tabelle angegebenen zulässigen Radialbelastungen gelten für Belastungen, die in der Mittellinie des langsamlaufenden Wellenendes auf einem Abstand von  $0,5 \cdot E$  ( $E$  = Länge des Wellenendes) vom Wellenabsatz angreifen. Liegt der Angriffspunkt bei  $0,315 \cdot E$ , die Tabellenwerte mit  $1,25$  multiplizieren; liegt er bei  $0,8 \cdot E$ , dann mit  $0,8$  multiplizieren.

## 19 - Radial loads $F_{r2}$ [daN] or axial loads $F_{a2}$ [daN] on low speed shaft end

### Axial loads $F_{a2}$

Permissible  $F_{a2}$  is shown in the column where direction of rotation of low speed shaft (black or white arrow) and direction of the axial force (solid or broken arrow) correspond to those of the gear reducer in question. Direction of rotation and direction of force may be established viewing the gear reducer from any point, providing the same point is adopted for both.

Wherever possible, choose the load conditions corresponding to the **column** with **highest** admissible values.

### Radial loads $F_{r2}$

Radial loads generated on the shaft end by a drive connecting gear reducer and machine must be less than or equal to those given in the relevant table.

Normally, radial loads on low speed shaft ends are considerable: in fact there is a tendency to connect the gear reducer to the machine by means of a transmission with high transmission ratio (economizing on the gear reducer) and with small diameters (economizing on the drive, and for requirements dictated by overall dimensions). Bearing life and wear (which also affect gears unfavourably) and low speed shaft strength, clearly impose limits on permissible radial load.

The high value which radial load may take on, and the importance of not exceeding permissible values, make it necessary to take full advantage of the gear reducer's possibilities.

Permissible radial loads given in the table are therefore based on: the low speed shaft side where radial load is applied with respect to the reference groove (see ch. 20 and ch. 8, 10, 13, 16), the product of speed  $n_2$  [min<sup>-1</sup>] multiplied by bearing life  $L_h$  [h] required, the direction of rotation, the angular position  $\varphi$  [°] of the load and torque  $M_2$  [daN m] required.

Radial loads given in the table are valid for overhung loads on centre line of low speed shaft end, i.e. operating at a distance of  $0,5 \cdot E$  ( $E$  = shaft end length) from the shoulder. If operating at  $0,315 \cdot E$  multiply by  $1,25$ ; if operating at  $0,8 \cdot E$  multiply by  $0,8$ .

19 - Radial- $F_{r2}$  [daN] oder Axialbelastungen  $F_{a2}$  [daN] auf dem langsamlaufenden Wellenende

19 - Radial loads  $F_{r2}$  [daN] or axial loads  $F_{a2}$  [daN] on low speed shaft end

Bei den üblichsten Antriebsfällen hat die Radialbelastung  $F_{r2}$  folgende Werte und Winkellagen:

Radial load  $F_{r2}$  for most common drives has the following value and angular position:

$$F_{r2} = \frac{1\,910 \cdot P_2}{d \cdot n_2} \text{ [daN]}$$

für Kettentrieb (Heben im allgemeinen); für Zahnriementrieb 1 910 mit 2 865 austauschen

for chain drive (lifting in general); for timing belt drive replace 1 910 with 2 865

$$F_{r2} = \frac{4\,775 \cdot P_2}{d \cdot n_2} \text{ [daN]}$$

für Keilriementrieb  
for V-belt drive

$$F_{r2} = \frac{2\,032 \cdot P_2}{d \cdot n_2} \text{ [daN]}$$

für Geradstirnradgetriebe  
for spur gear pair drive

$$F_{r2} = \frac{6\,781 \cdot P_2}{d \cdot n_2} \text{ [daN]}$$

für Reibradtrieb (Gummi auf Metall)  
for friction wheel drive (rubber-on-metal)



Drehung  
Rotation

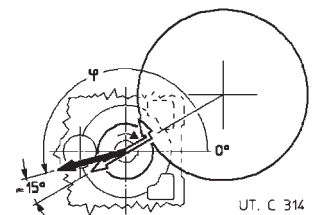
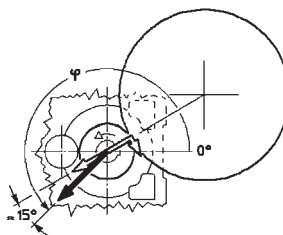
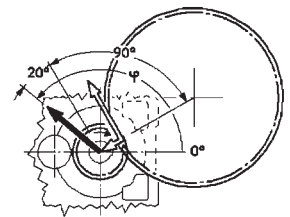
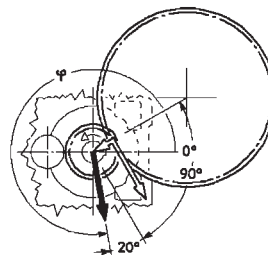
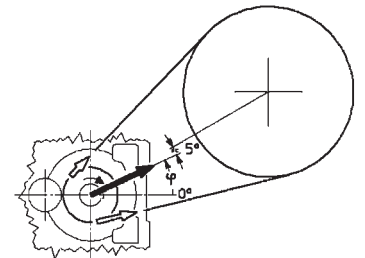
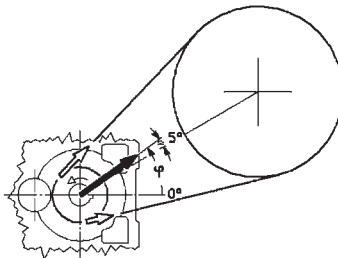
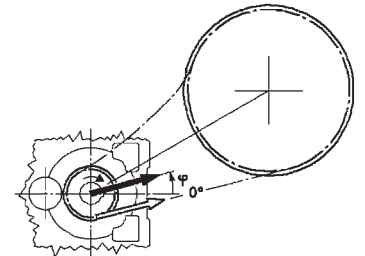
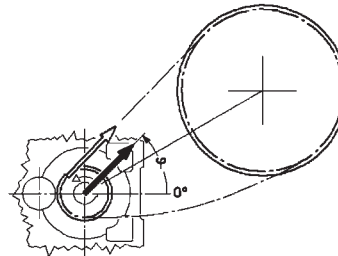

wo:  $P_2$  [kW] die an der Getriebeabtriebswelle erforderliche Leistung,  $n_2$  [ $\text{min}^{-1}$ ] die Drehzahl,  $d$  [m] der Teilkreisdurchmesser ist.

where:  $P_2$  [kW] is power required at the output side of the gear reducer,  $n_2$  [ $\text{min}^{-1}$ ] is the speed,  $d$  [m] is the pitch diameter.

**WICHTIG:**  $0^\circ$  fällt mit der durch die Achsen der letzten Untersetzungsstufe laufenden und wie im Bild orientierten Halbgerade zusammen, die daher der Gehäusedrehung folgt, wie unten angegeben.

**IMPORTANT:**  $0^\circ$  coincides with a straight line concurrent with the axis of the last reduction and orientated as shown above, and therefore it follows the rotation of the casing, as shown below.

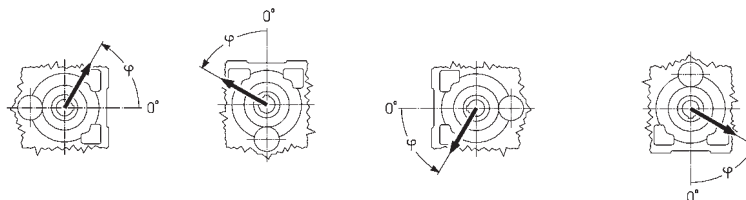

UT. C 914

19 - Radial- $F_{r2}$  [daN] oder Axialbelastungen  $F_{a2}$  [daN] auf dem langsamlaufenden Wellenende

Radialbelastung **an der Gegenseite der Rille**.

Bei Radialbelastungen gleichzeitig an beiden Seiten bitte rückfragen.

19 - Radial loads  $F_{r2}$  [daN] or axial loads  $F_{a2}$  [daN] on low speed shaft end

Applied radial load **opposite side to groove**.

For radial loads acting simultaneously on both sides consult us.

Größe size

40

$n_2 \cdot L_h$ min <sup>-1</sup> · h	$M_2$ daN m	$F_{r2}^{(1)}$															$F_{a2}^{(1)}$			
		0	45	90	135	180	225	270	315	0	45	90	135	180	225	270	315	80	160	
355 000	8	224	224	224	224	224	224	224	224	224	224	224	224	224	224	224	224	224	80	160
	5,6	224	224	224	224	224	224	224	224	224	224	224	224	224	224	224	224	224	80	160
	4	224	224	224	224	224	224	224	224	224	224	224	224	224	224	224	224	224	80	160
450 000	8	224	224	224	224	224	224	224	224	224	212	224	224	224	224	224	224	224	80	160
	5,6	224	224	224	224	224	224	224	224	224	224	224	224	224	224	224	224	224	80	160
	4	224	224	224	224	224	224	224	224	224	224	224	224	224	224	224	224	224	80	160
560 000	8	224	224	224	224	224	212	212	224	212	200	212	224	224	224	224	224	224	80	160
	5,6	224	224	224	224	224	224	224	224	224	212	224	224	224	224	224	224	224	80	160
	4	224	224	224	224	224	224	224	224	224	224	224	224	224	224	224	224	224	80	160
710 000	8	224	224	224	224	224	200	190	200	190	180	190	224	224	224	224	224	224	71	150
	5,6	224	224	224	224	224	224	200	212	200	190	200	224	224	224	224	224	224	80	160
	4	224	224	224	224	224	212	212	224	212	200	212	224	224	224	224	224	224	80	160
900 000	8	212	224	200	190	200	180	170	190	170	160	170	200	224	224	224	212	53	132	
	5,6	212	224	224	224	200	190	190	200	180	170	180	212	224	224	224	212	80	140	
	4	212	224	224	224	212	200	190	200	190	190	190	212	224	224	224	212	80	150	
1 120 000	8	200	236	150	140	190	160	160	170	160	140	150	190	224	200	190	190	40	118	
	5,6	200	224	224	212	190	170	170	180	170	160	170	190	224	224	224	200	71	125	
	4	200	212	212	212	190	180	180	190	180	170	180	200	212	224	212	200	80	132	
1 400 000	5,6	190	212	212	200	180	160	160	170	160	150	150	180	212	224	212	180	56	118	
	4	190	200	200	190	180	170	160	170	160	160	160	180	200	212	200	180	80	118	
	2,8	190	200	200	190	180	170	170	180	170	160	170	180	200	200	200	180	80	132	
1 800 000	5,6	170	190	200	180	160	140	140	150	140	132	140	160	190	212	190	170	48	100	
	4	170	190	190	180	160	150	150	160	150	140	150	170	190	200	190	170	67	112	
	2,8	170	180	180	180	170	160	160	160	160	150	150	170	180	190	180	170	80	112	
2 240 000	5,6	160	180	160	150	150	132	132	140	132	118	125	150	180	190	180	150	36	90	
	4	160	170	180	170	150	140	140	150	140	132	140	150	170	180	180	160	56	95	
	2,8	160	170	170	160	150	150	140	150	140	140	140	160	170	180	170	160	71	106	
2 800 000	4	150	160	170	160	140	132	125	132	125	118	125	140	160	170	160	140	50	85	
	2,8	150	160	160	150	140	132	132	140	132	125	132	140	160	170	160	150	63	90	
										max 224								max 80	max 160	

Größe size

50

355 000	16	300	315	315	315	315	315	280	250	315	315	280	300	315	315	315	315	224	112
	11,2	315	315	315	315	315	315	315	300	315	315	315	315	315	315	315	315	224	112
	8	315	315	315	315	315	315	315	315	315	315	315	315	315	315	315	315	224	112
450 000	16	265	315	315	315	315	315	250	240	315	280	250	280	315	315	315	315	224	90
	11,2	300	315	315	315	315	315	280	265	315	300	280	300	315	315	315	315	224	112
	8	315	315	315	315	315	315	300	300	315	315	300	315	315	315	315	315	224	112
560 000	16	236	315	315	315	315	300	224	200	315	250	224	250	315	315	315	315	200	71
	11,2	265	315	315	315	315	315	250	236	315	280	265	280	315	315	315	315	212	112
	8	280	315	315	315	315	315	280	265	315	300	280	300	315	315	315	315	224	112
710 000	16	200	300	315	315	315	265	190	170	300	224	200	224	280	280	300	315	180	50
	11,2	236	300	315	315	315	280	224	212	300	250	236	250	300	315	315	315	190	100
	8	265	300	315	315	315	300	250	236	300	265	250	265	300	315	315	315	200	112
900 000	16	180	265	300	315	315	236	170	150	265	200	180	200	265	200	224	315	160	33,5
	11,2	212	280	315	315	315	265	200	190	280	236	212	224	265	315	315	315	170	80
	8	236	280	315	315	315	265	224	224	280	250	236	250	280	315	315	315	180	112
1 120 000	16	160	236	236	265	315	212	140	125	250	180	160	180	212	132	150	315	150	18
	11,2	190	250	315	315	315	300	236	190	180	265	212	190	212	250	315	315	170	63
	8	212	265	315	315	315	300	250	212	200	265	224	212	224	250	300	315	160	95
1 400 000	11,2	180	236	315	315	300	212	170	150	236	190	170	190	236	280	300	300	140	50
	8	200	250	300	315	280	224	190	180	236	212	190	200	236	280	300	280	150	80
	5,6	212	250	280	300	265	236	212	200	250	224	212	224	236	265	280	265	150	112
1 800 000	11,2	160	212	280	315	280	190	150	132	212	170	150	170	212	224	250	280	125	35,5
	8	180	224	280	300	265	212	170	160	224	190	170	180	212	265	280	265	132	67
	5,6	190	224	265	280	250	212	190	180	224	200	190	200	224	250	265	250	132	90
2 240 000	11,2	140	200	236	265	250	180	125	118	200	150	140	150	190	180	190	265	112	23,6
	8	160	212	265	280	250	190	150	140	212	170	160	170	200	236	265	250	118	53
	5,6	180	212	250	250	236	200	170	160	212	180	170	180	200	236	250	236	125	80
2 800 000	8	150	200	250	265	236	180	140	132	200	160	150	160	190	224	250	236	106	45
	5,6	170	200	236	250	224	190	160	150	200	170	160	170	190	224	236	224	112	71
										max 315								max 224	max 112

1) Außer der Radialbelastung kann gleichzeitig eine Axialbelastung vorliegen, die das 0,2-fache der Tabellenwerte erreichen kann und umgekehrt. Bei höheren Werten bitte rückfragen.

1) An axial load of up to 0,2 times the value in the table is permissible, simultaneously with the radial load and vice versa. If exceeded consult us.

19 - Radial- $F_{r2}$  [daN] oder Axialbelastungen  $F_{a2}$  [daN] auf dem langsamlaufenden Wellenende

19 - Radial loads  $F_{r2}$  [daN] or axial loads  $F_{a2}$  [daN] on low speed shaft end

Radialbelastung **an der Seite der Rille** ●.  
Bei Radialbelastungen gleichzeitig an beiden Seiten bitte rückfragen.

Applied radial load **groove side** ●.  
For radial loads acting simultaneously on both sides consult us.

Größe 40  
size

$n_2 \cdot L_h$	$M_2$	$F_{r2}^{1)}$													$F_{a2}^{1)}$				
		0	45	90	135	180	225	270	315	0	45	90	135	180	225	270	315		
355 000	8	190	224	224	224	224	212	150	140	224	170	160	190	224	224	224	224	80	160
	5,6	224	224	224	224	224	224	190	190	224	212	200	224	224	224	224	224	80	160
	4	224	224	224	224	224	224	224	224	224	224	224	224	224	224	224	224	80	160
450 000	8	160	224	224	224	224	190	132	125	212	150	140	170	224	224	224	224	80	160
	5,6	200	224	224	224	224	224	170	170	224	190	180	200	224	224	224	224	80	160
	4	224	224	224	224	224	224	200	200	224	212	200	224	224	224	224	224	80	160
560 000	8	140	224	224	224	224	160	106	106	190	125	118	150	224	224	224	224	80	160
	5,6	180	224	224	224	224	200	150	150	212	170	160	190	224	224	224	224	80	160
	4	200	224	224	224	224	224	180	180	224	190	180	212	224	224	224	224	80	160
710 000	8	118	224	224	224	224	140	90	85	160	106	100	132	212	224	224	224	71	150
	5,6	160	224	224	224	224	180	132	132	190	150	140	170	224	224	224	224	80	160
	4	190	224	224	224	224	200	160	160	212	170	170	190	224	224	224	224	80	160
900 000	8	95	200	224	224	224	118	71	67	140	90	80	106	190	224	224	224	53	132
	5,6	140	212	224	224	224	160	118	112	170	132	118	150	212	224	224	224	80	140
	4	170	224	224	224	224	180	140	140	190	150	150	170	212	224	224	224	80	150
1 120 000	8	75	180	224	224	224	95	53	50	125	75	67	90	180	224	224	224	40	118
	5,6	125	200	224	224	224	140	100	95	160	112	106	132	190	224	224	224	71	125
	4	150	200	224	224	224	160	132	125	170	140	132	150	200	224	224	224	80	132
1 400 000	5,6	112	180	224	224	212	125	85	80	140	100	90	118	180	224	224	224	56	118
	4	140	190	224	224	212	150	118	112	160	125	118	140	190	224	224	212	80	118
	2,8	150	190	224	132	200	160	140	132	170	140	140	150	190	224	224	200	80	132
1 800 000	5,6	90	170	224	224	190	106	71	67	125	85	75	100	160	224	224	200	48	100
	4	118	170	224	224	190	132	100	95	140	112	106	125	170	224	224	200	67	112
	2,8	140	180	212	224	190	150	118	118	150	132	125	140	170	200	212	190	80	112
2 240 000	5,6	75	150	224	224	180	90	56	53	112	71	63	85	150	224	224	190	36	90
	4	106	160	224	224	180	118	85	85	125	95	90	112	160	212	224	180	56	95
	2,8	125	160	200	212	180	132	112	106	140	118	112	125	160	190	200	180	71	106
2 800 000	4	95	150	212	212	170	106	80	71	118	85	80	100	140	200	212	170	50	85
	2,8	112	150	190	200	160	125	100	95	132	106	100	112	150	180	190	170	63	90
<b>max 224</b>																	<b>max 80</b>	<b>max 160</b>	

Größe 50  
size

355 000	16	224	315	315	315	315	280	190	170	315	224	200	250	315	315	315	315	224	112
	11,2	280	315	315	315	315	315	250	236	315	280	265	300	315	315	315	315	224	112
	8	315	315	315	315	315	315	300	280	315	315	300	315	315	315	315	315	224	112
450 000	16	190	315	315	315	315	236	160	150	280	190	180	212	315	315	315	315	224	106
	11,2	250	315	315	315	315	300	224	212	315	250	236	265	315	315	315	315	224	112
	8	300	315	315	315	315	315	265	250	315	280	265	300	315	315	315	315	224	112
560 000	16	160	300	315	315	315	212	132	118	250	170	150	190	300	315	315	315	212	85
	11,2	224	315	315	315	315	265	200	180	300	224	200	236	315	315	315	315	224	112
	8	265	315	315	315	315	300	236	224	300	250	236	265	315	315	315	315	224	112
710 000	16	132	280	315	315	315	180	100	95	224	140	125	160	265	315	315	315	190	67
	11,2	200	300	315	315	315	236	170	160	265	200	180	212	300	315	315	315	200	112
	8	236	315	315	315	315	265	212	200	280	224	212	250	300	315	315	315	200	112
900 000	16	106	236	315	315	315	140	80	71	190	112	100	132	236	315	315	315	170	45
	11,2	170	280	315	315	315	212	150	132	236	170	160	190	265	315	315	315	180	90
	8	212	300	315	315	315	236	190	180	265	212	190	224	280	315	315	315	180	112
1 120 000	16	71	200	315	315	300	106	50	45	170	95	80	106	212	315	315	315	160	31,5
	11,2	150	250	315	315	315	190	125	118	212	150	140	170	250	315	315	315	160	75
	8	190	265	315	315	300	224	170	160	236	190	170	200	265	315	315	315	170	106
1 400 000	11,2	132	224	315	315	300	160	106	95	190	132	118	150	224	315	315	300	150	60
	8	170	250	315	315	280	200	150	140	212	170	150	180	236	315	315	300	150	90
	5,6	200	250	300	315	280	224	180	180	224	200	190	200	250	300	300	280	160	112
1 800 000	11,2	106	200	315	315	265	140	80	75	170	112	95	125	200	315	315	280	132	45
	8	150	224	315	315	265	180	125	118	190	150	132	160	224	300	315	265	140	71
	5,6	180	236	280	300	250	200	160	150	212	170	160	180	224	280	300	265	140	95
2 240 000	11,2	85	180	315	315	250	112	67	60	150	90	80	106	180	300	315	265	125	33,5
	8	132	212	300	315	250	160	112	106	180	132	118	140	200	280	300	250	125	60
	5,6	160	212	265	280	236	180	140	140	190	160	150	170	212	265	280	250	125	80
2 800 000	8	118	200	300	300	236	140	100	85	160	112	106	125	190	265	280	250	112	50
	5,6	150	200	250	265	224	170	132	125	180	150	132	150	200	250	265	236	118	71
<b>max 315</b>																	<b>max 224</b>	<b>max 112</b>	

1) Außer der Radialbelastung kann gleichzeitig eine Axialbelastung vorliegen, die das 0,2-fache der Tabellenwerte erreichen kann und umgekehrt. Bei höheren Werten bitte rückfragen.

1) An axial load of up to 0,2 times the value in the table is permissible, simultaneously with the radial load and vice versa. If exceeded consult us.

**19 - Radial- $F_{r2}$  [daN] oder Axialbelastungen  $F_{a2}$  [daN] auf dem langsamlaufenden Wellenende**

**19 - Radial loads  $F_{r2}$  [daN] or axial loads  $F_{a2}$  [daN] on low speed shaft end**

Radialbelastung **an der Gegenseite der Rille.**

Applied radial load **opposite side to groove.**

Bei Radialbelastungen gleichzeitig an beiden Seiten bitte rückfragen.

For radial loads acting simultaneously on both sides consult us.

Größe size **63, 64**

$n_2 \cdot L_h$  min <sup>-1</sup> · h	$M_2$  daN m	$F_{r2}^{1)}$																$F_{a2}^{1)}$		
		0	45	90	135	180	225	270	315	0	45	90	135	180	225	270	315	180	355	
<b>1 120 000</b>	31,5	500	500	500	500	500	500	500	500	500	500	500	500	500	500	500	500	500	180	355
	22,4	500	500	500	500	500	500	500	500	500	500	500	500	500	500	500	500	500	180	355
	16	500	500	500	500	500	500	500	500	500	500	500	500	500	500	500	500	500	180	355
	11,2	500	500	500	500	500	500	500	500	500	500	500	500	500	500	500	500	500	180	355
<b>1 400 000</b>	22,4	500	500	500	500	500	500	500	500	500	500	500	500	500	500	500	500	500	180	355
	16	500	500	500	500	500	500	500	500	500	500	500	500	500	500	500	500	500	180	355
	11,2	500	500	500	500	500	500	500	500	500	500	500	500	500	500	500	500	500	180	355
<b>1 800 000</b>	22,4	500	500	500	500	500	500	500	500	500	500	500	500	500	500	500	500	500	180	355
	16	500	500	500	500	500	500	500	500	500	500	500	500	500	500	500	500	500	180	355
	11,2	500	500	500	500	500	500	500	500	500	500	500	500	500	500	500	500	500	180	355
<b>2 240 000</b>	22,4	500	500	500	500	500	500	500	500	475	450	500	500	500	500	500	500	500	180	335
	16	500	500	500	500	500	500	500	500	500	500	500	500	500	500	500	500	500	180	335
	11,2	500	500	500	500	500	500	500	500	500	500	500	500	500	500	500	500	500	180	335
<b>2 800 000</b>	16	500	500	500	500	500	500	475	475	500	475	450	500	500	500	500	500	500	180	315
	11,2	500	500	500	500	500	500	500	500	500	475	500	500	500	500	500	500	500	180	315
<b>3 550 000</b>	16	500	500	500	500	475	450	450	475	425	425	425	500	500	500	500	500	475	180	300
	11,2	500	500	500	500	475	450	450	475	450	450	450	500	500	500	500	500	500	180	300
<b>4 500 000</b>	16	475	500	500	475	450	400	400	425	400	375	400	450	500	500	500	500	450	180	280
	11,2	475	500	500	475	450	425	425	450	425	400	425	450	500	500	500	500	450	180	280
<b>5 600 000</b>	16	450	475	475	450	400	375	375	400	375	355	375	425	475	500	475	425	160	265	
	11,2	450	475	475	450	425	400	400	400	375	375	400	425	475	475	475	425	180	265	
<b>7 100 000</b>	16	400	450	425	400	375	355	355	375	335	315	335	400	450	475	450	375	140	236	
	11,2	400	425	425	425	375	375	355	375	355	355	355	400	425	450	425	400	180	236	

**max 500**

Größe size **80, 81**

<b>355 000</b>	63	800	800	800	800	800	800	800	800	800	800	800	800	800	800	800	800	800	560	280
	45	800	800	800	800	800	800	800	800	800	800	800	800	800	800	800	800	800	560	280
	31,5	800	800	800	800	800	800	800	800	800	800	800	800	800	800	800	800	800	560	280
<b>450 000</b>	63	800	800	800	800	800	800	800	800	800	800	800	800	800	800	800	800	800	560	280
	45	800	800	800	800	800	800	800	800	800	800	800	800	800	800	800	800	800	560	280
	31,5	800	800	800	800	800	800	800	800	800	800	800	800	800	800	800	800	800	560	280
<b>560 000</b>	63	800	800	800	800	800	800	800	750	800	800	800	800	800	800	800	800	800	560	280
	45	800	800	800	800	800	800	800	800	800	800	800	800	800	800	800	800	800	560	280
	31,5	800	800	800	800	800	800	800	800	800	800	800	800	800	800	800	800	800	560	280
<b>710 000</b>	63	750	800	800	800	800	800	750	710	800	800	750	750	800	800	800	800	800	560	280
	45	800	800	800	800	800	800	800	750	800	800	800	800	800	800	800	800	800	560	280
	31,5	800	800	800	800	800	800	800	800	800	800	800	800	800	800	800	800	800	560	280
<b>900 000</b>	63	670	800	800	800	800	800	670	630	800	750	710	710	710	750	800	800	800	530	265
	45	750	800	800	800	800	800	800	750	710	800	800	800	800	800	800	800	800	560	280
	31,5	750	800	800	800	800	800	800	800	750	800	800	800	800	800	800	800	800	560	280
<b>1 120 000</b>	63	630	710	750	800	800	800	630	560	800	710	630	670	630	670	750	800	800	500	236
	45	670	800	800	800	800	800	670	630	800	750	710	710	750	800	800	800	800	500	280
	31,5	710	800	800	800	800	800	800	710	710	800	750	750	800	800	800	800	800	530	280
	22,4	750	800	800	800	800	800	750	710	800	800	750	750	800	800	800	800	800	530	280
<b>1 400 000</b>	45	630	750	800	800	800	750	630	600	800	710	630	630	710	750	800	800	800	475	280
	31,5	670	750	800	800	800	750	670	630	800	710	670	670	710	800	800	800	800	500	280
	22,4	710	750	800	800	800	750	710	670	750	710	710	710	750	800	800	800	800	500	280
<b>1 800 000</b>	45	560	670	750	800	800	670	560	530	750	630	600	600	630	670	710	800	800	425	250
	31,5	600	670	750	800	800	710	630	600	710	670	630	630	670	750	800	750	800	450	280
	22,4	630	710	750	800	800	750	710	630	630	670	630	630	670	710	750	750	800	450	280
<b>2 240 000</b>	45	530	630	670	750	750	630	530	500	670	600	530	560	560	600	670	710	800	400	224
	31,5	560	630	750	750	750	630	560	530	670	630	560	560	630	710	750	750	800	425	280
	22,4	600	630	710	750	710	670	600	560	710	670	600	600	630	670	710	710	800	425	280
<b>2 800 000</b>	31,5	530	600	670	750	710	600	530	500	630	560	530	530	600	630	670	670	800	400	265
	22,4	560	600	670	710	670	600	560	530	630	600	560	560	600	630	670	670	800	400	280
<b>3 550 000</b>	31,5	475	560	630	670	670	560	500	450	600	530	500	500	530	560	630	630	800	355	236
	22,4	500	560	630	670	630	560	500	500	600	530	530	530	560	600	630	630	800	375	280
<b>4 500 000</b>	31,5	450	530	560	630	630	530	450	425	560	500	450	450	500	530	560	600	800	335	200
	22,4	475	530	600	630	600	530	475	450	560	500	475	475	500	560	600	600	800	335	250
<b>5 600 000</b>	31,5	400	475	530	560	560	500	400	375	530	450	425	425	450	475	530	560	800	315	180
	22,4	425	500	560	560	560	500	450	425	500	475	450	450	475	530	560	560	800	315	224
<b>7 100 000</b>	31,5	375	450	475	530	530	450	375	355	475	425	375	400	400	425	475	530	800	280	160
	22,4	400	450	530	560	530	450	400	375	475	425	400	400	450	500	530	530	800	300	200

**max 800**

1) Außer der Radialbelastung kann gleichzeitig eine Axialbelastung vorliegen, die das 0,2-fache der Tabellenwerte erreichen kann und umgekehrt. Bei höheren Werten bitte rückfragen.

1) An axial load of up to 0,2 times the value in the table is permissible, simultaneously with the radial load and vice versa. If exceeded consult us.

19 - Radial- $F_{r2}$  [daN] oder Axialbelastungen  $F_{a2}$  [daN] auf dem langsamlaufenden Wellenende

Radialbelastung **an der Seite der Rille** ●.

Bei Radialbelastungen gleichzeitig an beiden Seiten bitte rückfragen.

19 - Radial loads  $F_{r2}$  [daN] or axial loads  $F_{a2}$  [daN] on low speed shaft end

Applied radial load **groove side** ●.

For radial loads acting simultaneously on both sides consult us.

Größe size **63, 64**

$n_2 \cdot L_h$ min <sup>-1</sup> · h	$M_2$ daN m	$F_{r2}^{1)}$													$F_{a2}^{1)}$					
		0	45	90	135	180	225	270	315	0	45	90	135	180	225	270	315	180	355	
<b>1 120 000</b>	31,5	500	500	500	500	500	500	500	475	500	500	425	450	500	500	500	500	500	180	355
	22,4	500	500	500	500	500	500	500	500	500	500	500	500	500	500	500	500	500	180	355
	16	500	500	500	500	500	500	500	500	500	500	500	500	500	500	500	500	500	180	355
	11,2	500	500	500	500	500	500	500	500	500	500	500	500	500	500	500	500	500	180	355
<b>1 400 000</b>	22,4	500	500	500	500	500	500	500	500	500	500	450	475	500	500	500	500	500	180	355
	16	500	500	500	500	500	500	500	500	500	500	500	500	500	500	500	500	500	180	355
	11,2	500	500	500	500	500	500	500	500	500	500	500	500	500	500	500	500	500	180	355
	11,2	500	500	500	500	500	500	500	500	500	500	500	500	500	500	500	500	500	180	355
<b>1 800 000</b>	22,4	500	500	500	500	500	475	450	475	475	400	425	500	500	500	500	500	500	180	355
	16	500	500	500	500	500	500	500	500	500	500	475	475	500	500	500	500	500	180	355
	11,2	500	500	500	500	500	500	500	500	500	500	500	500	500	500	500	500	500	180	355
	11,2	500	500	500	500	500	500	500	500	500	500	500	500	500	500	500	500	500	180	355
<b>2 240 000</b>	22,4	500	500	500	500	500	450	400	425	425	375	400	500	500	500	500	500	500	180	335
	16	500	500	500	500	500	475	450	475	475	425	450	500	500	500	500	500	500	180	335
	11,2	500	500	500	500	500	500	475	500	500	475	475	500	500	500	500	500	500	180	335
	11,2	500	500	500	500	500	500	475	500	500	500	475	500	500	500	500	500	500	180	335
<b>2 800 000</b>	16	500	500	500	500	500	450	400	425	425	400	400	475	500	500	500	500	500	180	315
	11,2	500	500	500	500	500	475	450	475	475	425	450	500	500	500	500	500	500	180	315
	11,2	475	500	500	500	475	400	375	400	400	355	375	450	500	500	500	500	500	180	300
	11,2	475	500	500	500	500	425	400	425	425	400	400	475	500	500	500	500	500	180	300
<b>4 500 000</b>	16	425	500	500	500	450	375	335	375	355	315	335	400	500	500	500	450	180	280	
	11,2	450	500	500	500	450	400	375	400	400	355	375	425	500	500	500	475	180	280	
	11,2	400	500	500	500	425	335	315	335	335	280	300	375	500	500	500	425	160	265	
	11,2	425	475	500	475	425	375	355	375	375	335	335	400	475	500	500	425	180	265	
<b>7 100 000</b>	16	375	475	500	475	400	315	280	300	300	265	280	355	475	500	500	400	140	236	
	11,2	375	450	475	450	400	335	315	335	335	300	315	375	450	500	475	400	180	236	
	11,2																			
	11,2																			
<b>max 500</b>																			<b>max 180</b>	<b>max 355</b>

Größe size **80, 81**

<b>355 000</b>	63	800	800	800	800	800	800	800	750	710	800	800	750	800	800	800	800	800	800	560	280
	45	800	800	800	800	800	800	800	800	800	800	800	800	800	800	800	800	800	800	560	280
	31,5	800	800	800	800	800	800	800	800	800	800	800	800	800	800	800	800	800	800	560	280
<b>450 000</b>	63	750	800	800	800	800	800	800	670	630	800	750	670	800	800	800	800	800	800	560	280
	45	800	800	800	800	800	800	800	800	750	800	800	800	800	800	800	800	800	800	560	280
	31,5	800	800	800	800	800	800	800	800	800	800	800	800	800	800	800	800	800	800	560	280
<b>560 000</b>	63	670	800	800	800	800	800	600	560	560	800	670	630	710	800	800	800	800	800	560	280
	45	800	800	800	800	800	800	800	710	670	800	750	710	800	800	800	800	800	800	560	280
	31,5	800	800	800	800	800	800	800	800	750	800	800	800	800	800	800	800	800	800	560	280
<b>710 000</b>	63	600	800	800	800	800	800	710	530	475	800	600	560	630	800	800	800	800	800	560	280
	45	710	800	800	800	800	800	800	630	600	800	710	670	750	800	800	800	800	800	560	280
	31,5	800	800	800	800	800	800	800	750	710	800	750	750	800	800	800	800	800	800	560	280
<b>900 000</b>	63	530	800	800	800	800	800	670	450	425	750	530	500	560	800	800	800	800	800	530	265
	45	630	800	800	800	800	800	750	560	560	800	630	600	670	800	800	800	800	800	560	280
	31,5	710	800	800	800	800	800	800	670	630	800	710	670	750	800	800	800	800	800	560	280
<b>1 120 000</b>	63	475	750	800	800	800	600	400	355	670	475	425	500	750	800	800	800	800	800	500	236
	45	600	800	800	800	800	670	530	500	750	600	530	600	800	800	800	800	800	800	500	280
	31,5	670	800	800	800	800	750	600	600	800	670	630	670	800	800	800	800	800	800	530	280
	22,4	710	800	800	800	800	750	670	670	800	710	670	710	800	800	800	800	800	800	530	280
<b>1 400 000</b>	45	530	750	800	800	800	630	475	450	670	530	500	560	750	800	800	800	800	800	475	280
	31,5	600	750	800	800	800	670	560	530	710	600	560	630	750	800	800	800	800	800	500	280
	22,4	670	750	800	800	800	710	630	600	750	630	630	670	750	800	800	800	800	800	500	280
	22,4	670	750	800	800	800	710	630	600	750	630	630	670	750	800	800	800	800	800	500	280
<b>1 800 000</b>	45	475	670	800	800	800	560	400	375	630	475	425	500	670	800	800	800	800	800	425	250
	31,5	560	710	800	800	800	630	500	475	670	560	500	560	710	800	800	800	800	800	450	280
	22,4	600	710	800	800	800	670	560	530	670	600	560	600	710	800	800	800	800	800	450	280
	22,4	600	710	800	800	800	670	560	530	670	600	560	600	710	800	800	800	800	800	450	280
<b>2 240 000</b>	45	425	630	800	800	800	500	375	335	560	425	400	450	630	800	800	800	800	800	400	224
	31,5	500	670	800	800	750	560	450	425	630	500	475	530	630	800	800	750	750	750	425	280
	22,4	560	670	800	800	750	600	530	500	630	560	530	560	670	750	800	750	750	750	425	280
	22,4	560	670	800	800	750	600	530	500	630	560	530	560	670	750	800	750	750	750	425	280
<b>2 800 000</b>	31,5	450	630	800	800	710	530	425	400	560	450	425	475	600	750	800	710	710	710	400	265
	22,4	500	630	750	750	670	560	475	450	600	500	475	530	600	710	750	710	710	710	400	280
	22,4	500	630	750	750	670	560	475	450	600	500	475	530	600	710	750	710	710	710	400	280
	22,4	500	630	750	750	670	560	475	450	600	500	475	530	600	710	750	710	710	710	400	280
<b>3 550 000</b>	31,5	425	560	750	800	670	475	375	355	530	425	375	425	560	710	750	670	670	670	355	236
	22,4	475	560	710	710	630	530	425	425	560	475	450	475	560	670	710	630	630	630	375	280
	22,4	475	560	710	710																

19 - Radial- $F_{r2}$  [daN] oder Axialbelastungen  $F_{a2}$  [daN] auf dem langsamlaufenden Wellenende

Radialbelastung **an der Gegenseite der Rille.**

Bei Radialbelastungen gleichzeitig an beiden Seiten bitte rückfragen.

19 - Radial loads  $F_{r2}$  [daN] or axial loads  $F_{a2}$  [daN] on low speed shaft end

Applied radial load **opposite side to groove.**

For radial loads acting simultaneously on both sides consult us.

Größe  
size **100**

$n_2 \cdot L_h$ min <sup>-1</sup> · h	$M_2$ daN m	$F_{r2}^{1)}$																$F_{a2}^{1)}$	
		0	45	90	135	180	225	270	315	0	45	90	135	180	225	270	315	450	900
<b>355 000</b>	125	1250	1250	1250	1250	1250	1250	1250	1250	1180	1120	1250	1250	1250	1250	1250	1250	450	900
	90	1250	1250	1250	1250	1250	1250	1250	1250	1250	1250	1250	1250	1250	1250	1250	1250	450	900
	63	1250	1250	1250	1250	1250	1250	1250	1250	1250	1250	1250	1250	1250	1250	1250	1250	450	900
<b>450 000</b>	125	1250	1250	1250	1180	1180	1180	1180	1250	1120	1060	1120	1250	1250	1250	1250	1250	450	900
	90	1250	1250	1250	1250	1250	1250	1250	1250	1180	1120	1250	1250	1250	1250	1250	1250	450	900
	63	1250	1250	1250	1250	1250	1250	1250	1250	1250	1250	1250	1250	1250	1250	1250	1250	450	900
<b>560 000</b>	125	1250	1250	1250	1060	1000	1060	1060	1180	1000	950	1060	1250	1250	1250	1250	1120	450	900
	90	1250	1250	1250	1250	1250	1120	1180	1250	1120	1060	1120	1250	1250	1250	1250	1250	450	900
	63	1250	1250	1250	1250	1250	1180	1180	1250	1180	1120	1180	1250	1250	1250	1250	1250	450	900
<b>710 000</b>	125	1250	1250	1120	950	900	950	1000	1120	900	850	950	1180	1250	1250	1060	1000	375	850
	90	1250	1250	1250	1180	1120	1060	1060	1180	1000	950	1060	1250	1250	1250	1250	1180	450	850
	63	1250	1250	1250	1250	1180	1120	1120	1180	1060	1060	1120	1250	1250	1250	1250	1180	450	900
<b>900 000</b>	125	1250	1120	1000	800	750	800	900	1060	850	750	850	1120	1250	1120	950	850	315	750
	90	1180	1250	1180	1060	1000	950	1000	1060	900	900	950	1120	1250	1250	1180	1060	450	800
	63	1180	1250	1250	1180	1060	1000	1000	1120	1000	950	1000	1180	1250	1250	1250	1120	450	850
<b>1 120 000</b>	125	1120	1000	800	710	630	670	850	950	750	710	800	1060	1120	1000	850	710	250	710
	90	1120	1180	1060	950	900	900	900	1000	850	800	900	1060	1250	1180	1060	1000	400	750
	63	1120	1180	1180	1120	1000	950	950	1000	900	900	950	1060	1180	1250	1180	1060	450	750
	45	1120	1180	1180	1120	1000	1000	1000	1060	950	950	1000	1060	1180	1180	1180	1060	450	800
<b>1 400 000</b>	90	1060	1120	950	850	800	800	850	950	800	750	800	1000	1180	1120	950	900	355	710
	63	1060	1120	1120	1060	950	900	900	950	850	800	850	1000	1120	1180	1120	950	450	710
	45	1060	1120	1060	1000	950	900	900	950	900	850	900	1000	1120	1120	1060	1000	450	750
<b>1 800 000</b>	90	1000	1000	850	750	710	750	750	850	710	670	750	900	1120	1000	850	750	300	630
	63	1000	1060	1000	950	850	800	800	900	750	750	800	950	1060	1120	1060	900	425	670
	45	950	1000	1000	950	900	850	850	900	800	800	850	950	1000	1060	1000	900	450	670
<b>2 240 000</b>	90	950	900	750	670	600	670	710	800	630	600	670	850	1000	900	750	670	250	600
	63	900	1000	900	850	800	750	750	800	710	670	750	850	1000	1060	950	850	375	630
	45	900	950	950	900	800	800	800	850	750	750	800	900	950	1000	950	850	450	630
<b>2 800 000</b>	63	850	950	850	750	750	670	710	750	670	630	670	800	950	950	850	750	335	560
	45	850	900	900	850	750	710	750	800	710	670	710	800	900	950	900	800	425	600
<b>3 550 000</b>	63	800	850	750	670	630	630	630	710	600	560	630	750	900	850	750	710	300	530
	45	800	850	850	800	710	670	670	710	630	630	670	750	850	900	850	750	375	560
<b>4 500 000</b>	63	750	750	670	600	560	560	600	670	560	530	560	710	850	750	670	630	250	500
	45	750	800	800	710	670	630	630	670	600	560	630	710	800	850	800	670	335	500
<b>5 600 000</b>	63	710	710	630	530	500	530	530	600	500	475	530	670	800	710	630	560	224	450
	45	710	750	710	670	630	560	560	630	560	530	560	670	750	800	750	630	300	475
<b>7 100 000</b>	63	670	630	560	475	425	475	500	560	450	425	475	600	710	630	530	500	190	425
	45	630	710	630	600	560	530	530	560	500	475	530	630	710	710	670	600	265	425
<b>max 1 250</b>																		<b>max 450</b>	<b>max 900</b>

1) Außer der Radialbelastung kann gleichzeitig eine Axialbelastung vorliegen, die das 0,2-fache der Tabellenwerte erreichen kann und umgekehrt. Bei höheren Werten bitte rückfragen.

1) An axial load of up to 0,2 times the value in the table is permissible, simultaneously with the radial load and vice versa. If exceeded consult us.



19 - Radial- $F_{r2}$  [daN] oder Axialbelastungen  $F_{a2}$  [daN] auf dem langsamlaufenden Wellenende

Radialbelastung **an der Seite der Rille** ●.

Bei Radialbelastungen gleichzeitig an beiden Seiten bitte rückfragen.

19 - Radial loads  $F_{r2}$  [daN] or axial loads  $F_{a2}$  [daN] on low speed shaft end

Applied radial load **groove side** ●.

For radial loads acting simultaneously on both sides consult us.

Größe size **100**

$n_2 \cdot L_h$ min <sup>-1</sup> · h	$M_2$ daN m	$F_{r2}^{1)}$														$F_{a2}^{1)}$			
		0	45	90	135	180	225	270	315	0	45	90	135	180	225	270	315		
<b>355 000</b>	125	1250	1250	1250	1250	1250	1060	950	1060	1000	800	900	1250	1250	1250	1250	1250	450	900
	90	1250	1250	1250	1250	1250	1180	1120	1180	1180	1000	1060	1250	1250	1250	1250	1250	450	900
	63	1250	1250	1250	1250	1250	1250	1250	1250	1250	1250	1180	1180	1250	1250	1250	1250	1250	450
<b>450 000</b>	125	1250	1250	1250	1250	1250	950	850	950	850	710	750	1120	1250	1250	1250	1250	450	900
	90	1250	1250	1250	1250	1250	1120	1000	1060	1060	900	950	1250	1250	1250	1250	1250	450	900
	63	1250	1250	1250	1250	1250	1180	1120	1180	1180	1060	1120	1250	1250	1250	1250	1250	450	900
<b>560 000</b>	125	1180	1250	1250	1250	1180	850	750	850	750	600	670	1000	1250	1250	1250	1250	450	900
	90	1250	1250	1250	1250	1250	1000	900	1000	950	800	850	1120	1250	1250	1250	1250	450	900
	63	1250	1250	1250	1250	1250	1120	1000	1120	1060	950	1000	1180	1250	1250	1250	1250	450	900
<b>710 000</b>	125	1060	1250	1250	1250	1060	750	670	750	670	530	560	900	1250	1250	1250	1120	375	850
	90	1120	1250	1250	1250	1180	900	800	900	850	710	750	1060	1250	1250	1250	1180	450	850
	63	1180	1250	1250	1250	1180	1000	950	1000	1000	850	900	1120	1250	1250	1250	1250	450	900
<b>900 000</b>	125	1000	1250	1250	1250	900	670	560	670	560	425	500	800	1250	1250	1250	1000	315	750
	90	1060	1250	1250	1250	1060	800	750	800	750	630	670	950	1250	1250	1250	1120	450	800
	63	1120	1250	1250	1250	1120	950	850	900	900	800	850	1060	1250	1250	1250	1120	450	850
<b>1 120 000</b>	125	900	1250	1250	1120	800	600	500	560	475	355	400	710	1250	1250	1250	900	250	710
	90	1000	1250	1250	1250	1000	750	670	750	670	560	630	850	1250	1250	1250	1000	400	750
	63	1000	1250	1250	1250	1060	850	800	850	800	710	750	950	1250	1250	1250	1060	450	750
	45	1060	1180	1250	1180	1060	900	850	900	900	800	850	1000	1180	1250	1250	1060	450	800
<b>1 400 000</b>	90	900	1250	1250	1120	950	670	600	670	600	500	530	800	1180	1250	1250	950	355	710
	63	950	1180	1250	1180	950	800	710	750	750	630	670	900	1180	1250	1250	1000	450	710
	45	1000	1120	1180	1120	1000	850	800	850	850	750	800	950	1120	1250	1180	1000	450	750
<b>1 800 000</b>	90	800	1180	1180	1060	800	600	500	560	530	425	475	710	1120	1250	1180	850	300	630
	63	850	1120	1250	1120	900	710	630	710	670	560	630	800	1120	1250	1180	900	425	670
	45	900	1060	1120	1060	900	750	710	750	750	670	710	850	1060	1180	1120	950	450	670
<b>2 240 000</b>	90	750	1060	1120	950	710	530	450	530	475	355	400	630	1060	1250	1060	800	250	600
	63	800	1060	1180	1060	850	630	560	630	600	500	560	750	1060	1250	1120	850	375	630
	45	850	1000	1060	1000	850	710	670	710	710	630	630	800	1000	1120	1060	850	450	630
<b>2 800 000</b>	63	750	1000	1060	950	750	600	530	560	560	450	500	670	950	1180	1060	800	335	560
	45	800	950	1000	950	800	670	600	630	630	560	600	750	950	1060	1000	800	425	600
<b>3 550 000</b>	63	710	950	1000	900	710	530	475	530	500	400	450	630	900	1120	1000	710	300	530
	45	710	900	950	900	750	600	560	600	560	500	530	670	900	1000	950	750	375	560
<b>4 500 000</b>	63	630	850	900	800	670	475	425	475	425	355	375	560	850	1000	900	670	250	500
	45	670	850	900	850	670	560	500	530	530	450	475	630	800	950	900	710	335	500
<b>5 600 000</b>	63	600	800	850	750	600	425	375	425	375	300	335	500	800	950	850	630	224	450
	45	630	800	850	800	630	500	450	500	475	400	425	560	800	900	850	630	300	475
<b>7 100 000</b>	63	530	750	800	670	500	375	315	375	335	250	280	450	750	900	750	560	190	425
	45	560	750	800	750	600	450	400	450	425	355	400	530	750	850	800	600	265	425
<b>max 1 250</b>																	<b>max 450</b>	<b>max 900</b>	

1) Außer der Radialbelastung kann gleichzeitig eine Axialbelastung vorliegen, die das 0,2-fache der Tabellenwerte erreichen kann und umgekehrt. Bei höheren Werten bitte rückfragen.

1) An axial load of up to 0,2 times the value in the table is permissible, simultaneously with the radial load and vice versa. If exceeded consult us.

19 - Radial- $F_{r2}$  [daN] oder Axialbelastungen  $F_{a2}$  [daN] auf dem langsamlaufenden Wellenende

19 - Radial loads  $F_{r2}$  [daN] or axial loads  $F_{a2}$  [daN] on low speed shaft end

Radialbelastung **an der Gegenseite der Rille.**  
Bei Radialbelastungen gleichzeitig an beiden Seiten bitte rückfragen.

Applied radial load **opposite side to groove.**  
For radial loads acting simultaneously on both sides consult us.

Größe  
size **125**

$n_2 \cdot L_h$ min <sup>-1</sup> · h	$M_2$ daN m	$F_{r2}^{1) 2)}$																$F_{a2}^{1)}$		
		0	45	90	135	180	225	270	315	0	45	90	135	180	225	270	315			
355 000	250	2000	2000	2000	2000	2000	2000	2000	1900	2000	2000	2000	2000	2000	2000	2000	2000	2000	1400	710
	180	2000	2000	2000	2000	2000	2000	2000	2000	2000	2000	2000	2000	2000	2000	2000	2000	2000	1400	710
450 000	250	1900	2000	2000	2000	2000	2000	2000	1900	1800	2000	2000	2000	2000	1900	2000	2000	2000	1400	710
	180	2000	2000	2000	2000	2000	2000	2000	2000	2000	2000	2000	2000	2000	2000	2000	2000	2000	1400	710
560 000	250	1700	1900	2000	2000	2000	2000	2000	1800	1600	2000	2000	1800	1800	1700	1800	2000	2000	1400	670
	180	1900	2000	2000	2000	2000	2000	2000	1900	1800	2000	2000	1900	1900	2000	2000	2000	2000	1400	710
710 000	250	1500	1600	1800	2000	2000	2000	2000	1600	1400	2000	1900	1700	1600	1500	1600	1900	2000	1320	560
	180	1700	2000	2000	2000	2000	2000	2000	1800	1600	2000	1900	1800	1800	1900	2000	2000	2000	1320	710
900 000	250	1400	1400	1600	1900	2000	1900	1500	1320	2000	1700	1500	1400	1250	1400	1600	1900	1180	475	
	180	1600	1800	2000	2000	2000	1900	1600	1500	2000	1800	1600	1600	1700	1800	2000	2000	1250	710	
	125	1700	1900	2000	2000	2000	1900	1700	1600	2000	1800	1700	1700	1800	2000	2000	2000	1250	710	
1 120 000	250	1250	1180	1400	1700	1900	1800	1320	1180	1900	1600	1400	1180	1060	1180	1500	1700	1120	375	
	180	1400	1700	1800	2000	2000	1800	1500	1320	1900	1700	1500	1500	1500	1600	1800	2000	1180	630	
	125	1500	1700	2000	2000	2000	1800	1600	1500	1900	1700	1600	1600	1700	1900	2000	2000	1180	710	
1 400 000	180	1320	1500	1600	1800	2000	1700	1400	1250	1800	1500	1400	1400	1400	1400	1600	1800	1060	530	
	125	1400	1600	1900	2000	1900	1700	1500	1400	1800	1600	1500	1500	1600	1700	1900	1900	1120	710	
	180	1180	1320	1400	1600	1800	1500	1250	1120	1700	1400	1250	1250	1180	1250	1400	1600	1000	450	
1 800 000	125	1320	1500	1700	1900	1800	1600	1320	1250	1600	1500	1400	1320	1400	1600	1700	1800	1000	630	
	180	1120	1180	1250	1500	1700	1400	1120	1000	1600	1320	1180	1120	1000	1120	1320	1500	950	400	
	125	1180	1400	1600	1700	1700	1400	1250	1180	1500	1400	1250	1250	1320	1400	1500	1700	950	560	
2 240 000	90	1120	1320	1400	1600	1600	1320	1180	1060	1400	1250	1180	1180	1250	1320	1400	1600	900	500	
	125	1180	1320	1500	1600	1500	1400	1180	1120	1400	1320	1250	1250	1320	1400	1500	1500	900	630	
	180	1000	1180	1320	1400	1500	1250	1060	950	1320	1180	1060	1060	1120	1180	1250	1400	800	450	
2 800 000	90	950	1060	1180	1320	1400	1180	950	900	1250	1120	1000	1000	1000	1100	1180	1320	750	400	
	125	1000	1120	1320	1400	1320	1180	1060	950	1250	1120	1060	1060	1120	1250	1320	1320	750	500	
	180	850	950	1060	1180	1320	1120	900	800	1180	1000	900	900	850	900	1060	1180	710	335	
3 550 000	90	950	1060	1250	1320	1250	1120	950	900	1180	1060	950	950	1060	1120	1180	1250	710	450	
	125	800	850	900	1060	1180	1000	800	750	1120	950	850	800	750	800	950	1060	670	280	
	180	850	1000	1120	1250	1180	1000	900	800	1060	950	900	900	950	1000	1120	1180	670	400	
<b>max 2 000</b>																	<b>max 1 400</b>	<b>max 710</b>		

Größe  
size **140**

280 000	375	2800	2800	2800	2800	2800	2800	2800	2800	2650	2800	2800	2800	2800	2800	2800	2800	2800	1800	900
	265	2800	2800	2800	2800	2800	2800	2800	2800	2800	2800	2800	2800	2800	2800	2800	2800	2800	1800	900
355 000	375	2500	2800	2800	2800	2800	2800	2650	2360	2800	2800	2650	2650	2800	2800	2800	2800	1800	900	
	265	2800	2800	2800	2800	2800	2800	2800	2650	2800	2800	2800	2800	2800	2800	2800	2800	1800	900	
450 000	375	2360	2800	2800	2800	2800	2800	2360	2120	2800	2650	2500	2500	2500	2650	2800	2800	1800	900	
	265	2500	2800	2800	2800	2800	2800	2650	2360	2800	2800	2650	2650	2800	2800	2800	2800	1800	900	
560 000	375	2120	2360	2650	2800	2800	2800	2240	2000	2800	2500	2240	2240	2120	2360	2650	2800	1700	750	
	265	2360	2650	2800	2800	2800	2800	2360	2240	2800	2650	2360	2360	2650	2800	2800	2800	1800	900	
710 000	375	1900	2120	2360	2800	2800	2500	2000	1800	2800	2360	2000	2000	1900	2500	2000	1800	1600	630	
	265	2120	2500	2800	2800	2800	2650	2240	2000	2800	2360	2240	2240	2500	2650	2800	2800	1600	900	
	190	2240	2500	2800	2800	2800	2650	2360	2240	2650	2500	2360	2360	2500	2800	2800	2800	1700	900	
900 000	375	1800	1800	2120	2500	2650	2360	1800	1600	2650	2120	1900	1700	1600	1800	2120	2360	1500	500	
	265	2000	2360	2650	2800	2800	2360	2000	1900	2500	2240	2000	2120	2240	2360	2650	2800	1500	850	
	190	2120	2360	2650	2800	2800	2500	2120	2000	2500	2360	2120	2120	2360	2500	2800	2650	1500	900	
1 120 000	265	1800	2240	2360	2650	2650	2240	1900	1700	2360	2120	1900	1900	2000	2120	2360	2650	1400	750	
	190	2000	2240	2500	2650	2650	2240	2000	1900	2360	2120	2000	2000	2120	2360	2500	2500	1400	900	
	265	1600	1900	2120	2360	2500	2120	1700	1500	2240	1900	1700	1700	1700	1900	2120	2360	1320	630	
1 400 000	190	1800	2120	2360	2500	2360	2120	1800	1700	2240	2000	1800	1900	2000	2240	2360	2360	1320	850	
	265	1500	1700	1900	2120	2360	1900	1500	1400	2120	1800	1600	1600	1500	1700	1900	2120	1180	530	
	190	1600	1900	2240	2360	2240	2000	1700	1600	2120	1800	1700	1700	1900	2000	2240	2240	1250	750	
2 240 000	132	1500	1800	2000	2240	2120	1800	1500	1400	1900	1700	1600	1600	1700	1800	2000	2120	1180	670	
	190	1600	1800	2000	2120	2120	1900	1600	1600	1900	1800	1700	1700	1800	1900	2120	2000	1180	850	
	132	1400	1700	1900	2000	2000	1700	1400	1320	1800	1600	1400	1400	1600	1600	1800	2000	1060	600	
2 800 000	132	1500	1700	1900	2000	1900	1700	1500	1400	1800	1600	1500	1500	1600	1600	1800	1900	1120	750	
	190	1250	1500	1700	1900	1900	1600	1320	1180	1700	1500	1320	1320	1400	1500	1600	1800	1000	500	
	132	1400	1600	1800	1900	1800	1600	1400	1320	1700	1500	1400	1400	1500	1700	1800	1800	1000	670	
4 500 000	190	1180	1400	1500	1700	1800	1500	1180	1060	1600	1320	1250	1250	1250	1320	1500	1600	900	450	
	132	1250	1500	1700	1800	1700	1500	1320	1250	1600	1400	1320	1320	1400	1600	1700	1700	950	630	
	190	1060	1180	1320	1500	1700	1400	1060	1000	1500	1250	1120	1120	1060	1180	1320	1500	850	375	
5 600 000	132	1180	1320	1600	1700	1600	1400	1180	1120	1500	1320	1180	1180	1320	1400	1600	1600	900	530	
	190	1060	1180	1320	1500	1700	1400	1060	1000	1500	1250	1120	1120	1060	1180	1320	1500	850	375	
	132	1180	1320	1600	1700	1600	1400	1180	1120	1500	1320	1180	1180	1320	1400	1600	1600	900	530	
<b>max 2 800 (max 1 600 bei «Kurzseite» for «short side»)</b>																	<b>max 1 800</b>	<b>max 900</b>		

1) Außer der Radialbelastung kann gleichzeitig eine Axialbelastung vorliegen, die das 0,2-fache der Tabellenwerte erreichen kann und umgekehrt. Bei höheren Werten bitte rückfragen.  
2) Eine ungünstige Belastungsrichtung kann  $F_{r2}</$

## 19 - Radial- $F_{r2}$ [daN] oder Axialbelastungen $F_{a2}$ [daN] auf dem langsamlaufenden Wellenende

Radialbelastung **an der Seite der Rille** ●.

Bei Radialbelastungen gleichzeitig an beiden Seiten bitte rückfragen.

## 19 - Radial loads $F_{r2}$ [daN] or axial loads $F_{a2}$ [daN] on low speed shaft end

Applied radial load **groove side** ●.

For radial loads acting simultaneously on both sides consult us.

Größe  
size **125**

$n_2 \cdot L_h$	$M_2$	$F_{r2}^{1)2)}$														$F_{a2}^{1)}$			
$\text{min}^{-1} \cdot \text{h}$	daN m	0	45	90	135	180	225	270	315	0	45	90	135	180	225	270	315		
<b>355 000</b>	250	1700	2000	2000	2000	2000	2000	1500	1400	2000	1800	1600	1800	2000	2000	2000	2000	1400	710
	180	2000	2000	2000	2000	2000	2000	1800	1700	2000	2000	1900	2000	2000	2000	2000	2000	1400	710
<b>450 000</b>	250	1500	2000	2000	2000	2000	1900	1320	1250	2000	1600	1400	1600	2000	2000	2000	2000	1400	710
	180	1800	2000	2000	2000	2000	2000	1600	1500	2000	1800	1700	1900	2000	2000	2000	2000	1400	710
<b>560 000</b>	250	1320	2000	2000	2000	2000	1700	1180	1060	2000	1400	1320	1500	2000	2000	2000	2000	1400	670
	180	1600	2000	2000	2000	2000	1900	1500	1400	2000	1700	1500	1700	2000	2000	2000	2000	1400	710
<b>710 000</b>	250	1180	1900	2000	2000	2000	1500	1000	900	1800	1320	1120	1320	1700	2000	2000	2000	1320	560
	180	1500	2000	2000	2000	2000	1800	1320	1250	1900	1500	1400	1500	2000	2000	2000	2000	1320	710
<b>900 000</b>	250	1000	1700	2000	2000	2000	1400	850	800	1600	1120	1000	1180	1500	2000	2000	2000	1180	475
	180	1320	1900	2000	2000	2000	1600	1180	1120	1800	1400	1250	1400	1800	2000	2000	2000	1250	710
	125	1500	1900	2000	2000	2000	1700	1400	1320	1800	1500	1400	1600	1900	2000	2000	2000	1250	710
<b>1 120 000</b>	250	850	1500	2000	2000	2000	1250	750	670	1500	1000	850	1060	1320	1800	2000	2000	1120	375
	180	1180	1700	2000	2000	2000	1500	1060	1000	1600	1250	1120	1250	1700	2000	2000	2000	1180	630
<b>1 400 000</b>	250	1400	1800	2000	2000	2000	1600	1320	1250	1700	1400	1320	1400	1700	2000	2000	2000	1180	710
	180	1060	1600	2000	2000	2000	1320	950	850	1500	1120	1000	1180	1600	1900	2000	2000	1060	530
<b>1 800 000</b>	250	1250	1700	2000	2000	2000	1500	1180	1120	1600	1320	1250	1320	1600	2000	2000	2000	1120	710
	125	900	1400	2000	2000	1900	1180	800	750	1400	1000	900	1000	1400	1700	2000	1900	1000	450
<b>2 240 000</b>	250	1180	1500	2000	2000	2000	1400	1060	1000	1500	1180	1120	1180	1500	1900	2000	1800	1000	630
	125	800	1320	1800	2000	1800	1060	710	630	1250	900	800	900	1180	1600	1800	1800	1000	400
<b>2 800 000</b>	250	1060	1400	1900	2000	1700	1250	950	900	1400	1060	1000	1120	1400	1800	1900	1700	950	560
	90	950	1320	1800	1900	1600	1180	850	800	1250	1000	900	1000	1320	1600	1800	1600	900	500
<b>3 550 000</b>	250	1060	1400	1700	1800	1600	1250	1000	950	1320	1120	1060	1120	1320	1600	1700	1600	900	630
	90	850	1250	1700	1800	1500	1060	750	710	1180	900	800	900	1180	1500	1600	1500	800	450
<b>4 500 000</b>	250	1000	1250	1600	1700	1500	1120	900	850	1180	1000	950	1000	1250	1500	1600	1500	850	560
	90	750	1120	1500	1700	1400	950	670	630	1060	800	710	800	1120	1320	1500	1400	750	400
<b>5 600 000</b>	250	900	1180	1500	1600	1400	1060	800	750	1120	900	850	950	1120	1400	1500	1400	750	500
	90	670	1060	1400	1600	1320	850	600	530	1000	710	630	750	1000	1250	1400	1400	710	335
<b>7 100 000</b>	250	1060	850	750	710	1060	850	750	710	1060	850	750	850	1060	1320	1400	1320	710	450
	90	600	950	1250	1400	1250	750	500	475	900	630	560	670	850	1120	1320	1250	670	280
		750	1000	1320	1400	1250	900	670	630	950	750	710	750	1000	1250	1320	1250	670	400
<b>max 2 000</b>																	<b>max 1 400</b>	<b>max 710</b>	

Größe  
size **140**

<b>280 000</b>	375	2360	2800	2800	2800	2800	2800	2240	2000	2800	2500	2240	2500	2800	2800	2800	2800	1800	900
	265	2800	2800	2800	2800	2800	2800	2500	2500	2800	2800	2650	2800	2800	2800	2800	2800	1800	900
<b>355 000</b>	375	2120	2800	2800	2800	2800	2800	2650	1900	1800	2800	2240	2000	2360	2800	2800	2800	1800	900
	265	2500	2800	2800	2800	2800	2800	2360	2240	2800	2650	2360	2650	2800	2800	2800	2800	1800	900
<b>450 000</b>	375	1900	2800	2800	2800	2800	2500	1700	1600	2800	2120	1900	2120	2800	2800	2800	2800	1800	900
	265	2360	2800	2800	2800	2800	2650	2120	2000	2800	2360	2240	2360	2800	2800	2800	2800	1800	900
<b>560 000</b>	375	1700	2650	2800	2800	2800	2240	1500	1400	2500	1900	1600	1900	2500	2800	2800	2800	1700	750
	265	2120	2800	2800	2800	2800	2500	1900	1800	2650	2000	2000	2120	2650	2800	2800	2800	1800	900
<b>710 000</b>	375	1500	2360	2800	2800	2800	2000	1320	1180	2360	1600	1400	1700	2120	2800	2800	2800	1600	630
	265	1900	2500	2800	2800	2800	2240	1700	1600	2500	2000	1800	2000	2500	2800	2800	2800	1600	900
	190	2120	2650	2800	2800	2800	2360	2000	1900	2500	2120	2000	2120	2500	2800	2800	2800	1700	900
<b>900 000</b>	375	1320	2120	2800	2800	2800	1800	1120	1000	2120	1500	1320	1500	1900	2500	2800	2800	1500	500
	265	1700	2360	2800	2800	2800	2120	1500	1400	2240	1800	1600	1800	2360	2800	2800	2800	1500	850
	190	1900	2500	2800	2800	2800	2240	1800	1700	2360	2000	1900	2000	2360	2800	2800	2800	1500	900
<b>1 120 000</b>	265	1500	2240	2800	2800	2800	1900	1400	1250	2120	1600	1500	1600	2120	2650	2800	2800	1400	750
	190	1800	2240	2800	2800	2800	2650	2120	1700	1600	2240	1800	1700	1800	2240	2650	2650	1400	900
<b>1 400 000</b>	265	1320	2000	2650	2800	2500	1700	1250	1120	1900	1400	1320	1500	2000	2360	2650	2650	1320	630
	190	1600	2120	2650	2800	2500	1900	1500	1400	2000	1700	1500	1700	2000	2500	2500	2500	1320	850
<b>1 800 000</b>	265	1180	1900	2500	2800	2360	1600	1060	1000	1800	1320	1180	1320	1700	2120	2500	2500	1180	530
	190	1500	2000	2500	2650	2360	1700	1320	1250	1900	1500	1400	1500	1900	2360	2650	2360	1250	750
<b>2 240 000</b>	190	1320	1800	2360	2650	2240	1600	1250	1120	1800	1400	1250	1400	1800	2240	2360	2240	1180	670
	132	1500	1900	2240	2360	2120	1700	1400	1320	1800	1500	1400	1500	1800	2120	2240	2120	1180	850
<b>2 800 000</b>	190	1180	1700	2240	2500	2120	1500	1060	1000	1600	1250	1120	1300	1600	2000	2240	2120	1060	600
	132	1400	1700	2120	2240	2000	1600	1320	1250	1700	1400	1320	1400	1700	2000	2120	2000	1120	750
<b>3 550 000</b>	190	1060	1500	2120	2360	1900	1320	950	900	1500	1120	1000	1180	1500	1800	2120	2000	1000	500
	132	1250	1600	2000	2120	1900	1400	1180	1120	1500	1320	1180	1320	1500	1900	2000	1900	1000	670
<b>4 500 000</b>	190	950	1400	1900	2120	1800	1250	850	800	1400	1000	900	1060	1400	1700	1900	1900	900	450
	132	1180	1500	1900	2000	1800	1320	1060	1000	1400	1180	1120	1180	1500	1800	1900	1800	950	630
<b>5 600 000</b>	190	850	1320	1700	2000	1700	1120	750	670	1250	900	800	950	1250	1500	1800	1700	850	375
	132	1000	1400	1800	1900	1600	1250	950	900	1320	1060	1000	1120	1320	1700	1800	1700	900	530
<b>max 2 800 (max 1 600 bei «Kurzseite» für «short side»)</b>																	<b>max 1 800</b>	<b>max 900</b>	

1) Außer der Radialbelastung kann gleichzeitig eine Axialbelastung vorliegen, die das 0,2-fache der Tabellenwerte erreichen kann und umgekehrt.

19 - Radial- $F_{r2}$  [daN] oder Axialbelastungen  $F_{a2}$  [daN]  
auf dem langsamlaufenden Wellenende

19 - Radial loads  $F_{r2}$  [daN] or axial loads  $F_{a2}$   
[daN] on low speed shaft end

Radialbelastung **an der Gegenseite der Rille**.  
Bei Radialbelastungen gleichzeitig an beiden Seiten bitte rückfragen.

Applied radial load **opposite side to groove**.  
For radial loads acting simultaneously on both sides consult us.

Größe  
size **160**

$n_2 \cdot L_h$	$M_2$	$F_{r2}^{1) 2)}$												$F_{a2}^{1)}$					
		0	45	90	135	180	225	270	315	0	45	90	135	180	225	270	315		
min <sup>-1</sup> · h	daN m																		
280 000	560 400	3550	3550	3550	3350	3350	3150	3150	3350	3000	2800	3000	3550	3550	3550	3550	3550	1120	2240
355 000	560 400	3550	3550	3350	3000	2800	2800	3150	2650	2500	2800	3350	3550	3550	3550	3350	3150	1120	2240
450 000	560 400	3350	3350	3000	2650	2500	2650	2650	2800	2500	2360	2500	3150	3550	3350	3000	2800	1060	2120
560 000	560 400	3150	3150	2650	2360	2240	2360	2360	2240	2120	2360	2800	3350	3150	2650	2360	2800	900	1900
710 000	560 400 280	3000	2800	2240	2000	1900	2000	2240	2000	1900	2120	2650	3000	2800	2360	2120	2800	750	1800
900 000	560 400 280	2800	2500	1900	1700	1600	1700	2000	2240	2120	2360	2800	3150	3150	3000	2650	2500	600	1600
1 120 000	400 280	2500	2650	2360	2120	2000	2000	2000	2240	2120	2360	2800	2800	2650	2360	2240	2800	850	1600
1 400 000	400 280	2360	2360	2120	1900	1800	1800	2000	2000	1700	1600	1800	2240	2650	2360	2120	2000	750	1500
1 800 000	400 280	2240	2240	1900	1700	1600	1700	1700	1900	1600	1500	1600	2120	2360	2120	1900	1700	630	1400
2 240 000	280 200	2120	2240	2120	1900	1800	1700	1700	1800	1600	1500	1700	2000	2240	2240	2120	1900	800	1320
2 800 000	280 200	1900	2120	1900	1700	1600	1500	1500	1700	1600	1400	1500	1800	2120	2120	1900	1800	710	1250
3 550 000	280 200	1800	1900	1700	1500	1400	1400	1400	1600	1320	1250	1400	1700	2000	1900	1700	1600	600	1120
4 500 000	280 200	1700	1700	1500	1320	1250	1320	1320	1400	1250	1180	1250	1600	1900	1700	1500	1400	530	1060
5 600 000	280 200	1600	1500	1320	1180	1120	1180	1180	1320	1250	1180	1180	1500	1700	1500	1320	1250	450	950
max <b>3 550</b>																		max <b>1 120</b>	max <b>2 240</b>

Größe  
size **180**

280 000	800 560	4500	4500	4500	4500	4500	4250	4000	4500	4000	3750	4000	4500	4500	4500	4500	4500	1400	2800
355 000	800 560	4500	4500	4500	4250	4000	3750	3750	4250	3550	3350	3550	4500	4500	4500	4500	4500	1400	2800
450 000	800 560	4500	4500	4500	4000	3550	3550	3550	3750	3350	3150	3350	4250	4500	4500	4500	4000	1400	2800
560 000	800 560	4250	4500	4000	3550	3150	3150	3150	3550	3000	2800	3150	3750	4500	4500	4000	3550	1180	2500
710 000	800 560 400	4000	4000	3550	3000	2800	2800	2800	3350	2800	2500	2800	3550	4250	4500	4000	3550	1000	2360
900 000	800 560 400	3750	3550	3000	2650	2360	2500	2650	3000	2500	2240	2500	3350	4000	4500	3150	2650	850	2120
1 120 000	560 400	3350	3750	3550	3150	3000	2650	2650	3000	2650	2360	2650	3150	4000	3750	3550	3150	1180	2120
1 400 000	560 400	3150	3350	3150	2800	2500	2500	2500	2650	2360	2120	2360	3000	3750	3550	3150	2800	1000	1900
1 800 000	560 400	3000	3150	2800	2500	2240	2240	2240	2500	2120	2000	2240	2800	3550	3150	2800	2500	850	1800
2 240 000	400 280	2800	3150	3000	2650	2500	2240	2240	2500	2120	2000	2240	2800	3550	3150	3000	2650	1060	1700
2 800 000	400 280	2650	2800	2650	2500	2360	2120	2000	2240	2000	1900	2000	2500	3000	3000	2650	2360	950	1600
3 550 000	400 280	2360	2650	2360	2240	2000	1900	1900	2120	2000	1900	2000	2360	2650	2800	2650	2240	800	1500
4 500 000	400 280	2240	2500	2240	2000	1800	1800	1700	1900	1700	1500	1700	2120	2650	2500	2240	2000	710	1400
5 600 000	400 280	2120	2240	2000	1700	1600	1600	1600	1800	1500	1400	1500	2000	2500	2240	2000	1800	600	1250
max <b>4 500</b> (max <b>2 500</b> bei «Kurzseite» for «short side»)																		max <b>1 400</b>	max <b>2 800</b>

1) Außer der Radialbelastung kann gleichzeitig eine Axialbelastung vorliegen, die das 0,2-fache der Tabellenwerte erreichen kann und umgekehrt. Bei höheren Werten bitte rückfragen.  
2) Eine ungünstige Belastungsrichtung kann  $F_{r2}$  zu  $0,9 \cdot F_{r2max}$  einschränken.

1) An axial load of up to 0,2 times the value in the table is permissible, simultaneously with the radial load and vice versa. If exceeded consult us.  
2) An unfavourable direction of load can limit  $F_{r2}$  to  $0,9 \cdot F_{r2max}$ .

19 - Radial- $F_{r2}$  [daN] oder Axialbelastungen  $F_{a2}$  [daN] auf dem langsamlaufenden Wellenende

Radialbelastung **an der Seite der Rille** ●.

Bei Radialbelastungen gleichzeitig an beiden Seiten bitte rückfragen.

19 - Radial loads  $F_{r2}$  [daN] or axial loads  $F_{a2}$  [daN] on low speed shaft end

Applied radial load **groove side** ●.

For radial loads acting simultaneously on both sides consult us.

Größe size **160**

$n_2 \cdot L_h$	$M_2$	$F_{r2}^{1) 2)}$														$F_{a2}^{1)}$			
		0	45	90	135	180	225	270	315	0	45	90	135	180	225	270	315		
min <sup>-1</sup> · h	daN m																		
<b>280 000</b>	560 400	3350	3550	3550	3550	3550	2500	2240	2500	2360	1900	2120	2800	3550	3550	3550	3550	1120	2240
<b>355 000</b>	560 400	3000	3550	3550	3550	3150	2240	2000	2120	2120	1700	1800	2650	3550	3550	3550	3350	1120	2240
<b>450 000</b>	560 400	2800	3550	3550	3550	3000	2000	1700	1900	1800	1400	1600	2360	3550	3550	3550	3000	1060	2120
<b>560 000</b>	560 400	2500	3550	3550	3350	2650	1800	1500	1700	1600	1250	1320	2120	3550	3550	3550	2800	900	1900
<b>710 000</b>	560 400 280	2240	3350	3550	3150	2240	1600	1320	1500	1320	1000	1120	1800	3350	3550	3550	2500	750	1800
<b>900 000</b>	560 400 280	2000	3150	3350	2800	2000	1400	1120	1320	1120	850	950	1600	3150	3550	3150	2240	600	1600
<b>1 120 000</b>	400 280	2120	3000	3150	2800	2240	1600	1400	1500	1500	1180	1320	1900	2800	3550	3150	2360	850	1600
<b>1 400 000</b>	400 280	1900	2800	3000	2650	2120	1400	1180	1400	1320	1000	1120	1600	2650	3350	3000	2120	750	1500
<b>1 800 000</b>	400 280	1800	2650	2800	2360	1900	1250	1060	1180	1500	850	950	1500	2500	3150	2650	2000	630	1400
<b>2 240 000</b>	280 200	1800	2360	2650	2360	1900	1400	1250	1400	1320	1120	1180	1600	2360	2800	2650	1900	800	1320
<b>2 800 000</b>	280 200	1600	2240	2500	2240	1700	1250	1120	1250	1400	950	1060	1400	2240	2650	2500	1800	710	1250
<b>3 550 000</b>	280 200	1500	2120	2240	2000	1600	1120	1000	1120	1060	850	900	1320	2000	2500	2240	1600	600	1120
<b>4 500 000</b>	280 200	1400	2000	2120	1900	1500	1000	850	1000	950	710	800	1180	1900	2360	2120	1500	530	1060
<b>5 600 000</b>	280 200	1250	1900	2000	1700	1320	900	750	850	1060	600	670	1060	1800	2120	1900	1400	450	950
<b>max 3 550</b>																		<b>max 1 120</b>	<b>max 2240</b>

Größe size **180**

<b>280 000</b>	800 560	4500	4500	4500	4500	4500	3550	3150	3350	3350	2650	3000	4000	4500	4500	4500	4500	1400	2800
<b>355 000</b>	800 560	4250	4500	4500	4500	4250	3150	2800	3150	3000	2360	2500	3750	4500	4500	4500	4500	1400	2800
<b>450 000</b>	800 560	3750	4500	4500	4500	4000	2800	2500	2800	2650	2120	2240	3350	4500	4500	4500	4000	1400	2800
<b>560 000</b>	800 560	3550	4500	4500	4500	3750	2500	2120	2500	2240	1800	2000	3000	4500	4500	4500	3750	1180	2500
<b>710 000</b>	800 560 400	3150	4500	4500	4250	3150	2240	1900	2120	2000	1500	1700	2650	4500	4500	4500	3350	1000	2360
<b>900 000</b>	800 560 400	2800	4250	4500	3750	2800	2000	1600	1900	1700	1250	1400	2360	4250	4500	4500	3150	850	2120
<b>1 120 000</b>	560 400	3000	4000	4500	4000	3150	2240	2000	2240	2120	1700	1900	2650	4000	4500	4500	3150	1180	2120
<b>1 400 000</b>	560 400	2650	3750	4000	3550	2800	2000	1700	2000	1800	1500	1600	2360	3750	4500	4000	2800	1000	1900
<b>1 800 000</b>	560 400	2500	3550	3750	3350	2650	1800	1500	1700	1600	1250	1400	2120	3550	4250	3750	2650	850	1800
<b>2 240 000</b>	400 280	2500	3150	3550	3350	2500	2000	1700	1900	1900	1500	1700	2240	3150	3750	3550	2650	1060	1700
<b>2 800 000</b>	400 280	2240	3000	3350	3000	2360	1800	1600	1700	1700	1400	1500	2000	3000	3550	3350	2500	950	1600
<b>3 550 000</b>	400 280	2120	2800	3150	2800	2240	1600	1400	1500	1800	1500	1600	2000	2650	3150	3000	2360	800	1500
<b>4 500 000</b>	400 280	1900	2650	2800	2500	2000	1400	1250	1400	1600	1400	1500	1900	2500	3000	2800	2120	710	1400
<b>5 600 000</b>	400 280	1700	2500	2650	2360	1800	1250	1120	1250	1120	900	1000	1500	2500	3000	2650	1900	600	1250
<b>max 4 500 (max 2 500 bei «Kurzseite» for «short side»)</b>																		<b>max 1 400</b>	<b>max 2800</b>

1) Außer der Radialbelastung kann gleichzeitig eine Axialbelastung vorliegen, die das 0,2-fache der Tabellenwerte erreichen kann und umgekehrt. Bei höheren Werten bitte rückfragen.  
2) Eine ungünstige Belastungsrichtung kann  $F_{r2}$  zu  $0,9 \cdot F_{r2max}$  einschränken.

1) An axial load of up to 0,2 times the value in the table is permissible, simultaneously with the radial load and vice versa. If exceeded consult us.  
2) An unfavourable direction of load can limit  $F_{r2}$  to  $0,9 \cdot F_{r2max}$ .

# 19 - Radial- $F_{r2}$ [daN] oder Axialbelastungen $F_{a2}$ [daN] auf dem langsamlaufenden Wellenende

Radialbelastung **an der Gegenseite der Rille.**  
Bei Radialbelastungen gleichzeitig an beiden Seiten bitte rückfragen.

# 19 - Radial loads $F_{r2}$ [daN] or axial loads $F_{a2}$ [daN] on low speed shaft end

Applied radial load **opposite side to groove.**  
For radial loads acting simultaneously on both sides consult us.

Größe  
size **200**

$n_2 \cdot L_h$ min <sup>-1</sup> · h	$M_2$ daN m	$F_{r2}^{1)2)}$												$F_{a2}^{1)}$					
		0	45	90	135	180	225	270	315	0	45	90	135	180	225	270	315		
<b>280 000</b>	1 120	4750	5600	5600	5600	5600	5600	5000	4500	5600	5600	5000	5000	5000	5300	5600	5600	3550	1800
	800	5300	5600	5600	5600	5600	5600	5300	5000	5600	5600	5300	5300	5600	5600	5600	5600	3550	1800
<b>355 000</b>	1 120	4500	5000	5600	5600	5600	5600	4500	4000	5600	5300	4750	4750	4500	4750	5600	5600	3550	1700
	800	4750	5600	5600	5600	5600	5600	5000	4500	5600	5300	5000	5000	5300	5600	5600	5600	3550	1800
<b>450 000</b>	1 120	4000	4250	5000	5600	5600	5300	4250	3750	5600	4750	4250	4250	4000	4250	5000	5600	3350	1400
	800	4500	5000	5600	5600	5600	5300	4500	4250	5600	5000	4500	4500	5000	5300	5600	5600	3350	1800
<b>560 000</b>	1 120	3550	3750	4250	5000	5600	4750	3750	3350	5300	4500	4000	3550	3350	3750	4250	5000	3150	1180
	800	4000	4750	5300	5600	5600	5000	4250	3750	5300	4500	4250	4250	4500	4750	5300	5600	3150	1800
<b>710 000</b>	1 120	3350	3150	3750	4500	5000	4500	3350	3000	4750	4000	3550	3000	2800	3150	3750	4500	2800	950
	800	3750	4500	4750	5300	5300	4500	3750	3550	5000	4250	3750	3750	4000	4250	4750	5300	3000	1600
<b>900 000</b>	1 120	2650	2650	3150	4000	4500	4250	3150	2800	4250	3750	3350	2500	2360	2650	3350	4000	2650	750
	800	3350	4000	4250	4750	5000	4250	3550	3150	4500	4000	3550	3550	3550	3750	4250	4750	2800	1400
<b>1 120 000</b>	800	3750	4250	4750	5000	5000	4250	3750	3550	4500	4000	3750	3750	4000	4500	5000	5000	2800	1800
	560	3150	3550	3750	4500	4750	4000	3150	3000	4250	3750	3350	3350	3150	3350	3750	4250	2500	1180
<b>1 400 000</b>	800	2800	3000	3350	4000	4250	3750	3000	2650	4000	3350	3000	3000	2800	3000	3350	3750	2360	1000
	560	3150	3550	4250	4500	4250	3750	3150	3000	4000	3350	3150	3150	3550	3750	4000	4250	2360	1500
<b>1 800 000</b>	800	2650	2650	3000	3550	4000	3350	2650	2360	3750	3150	2800	2500	2360	2650	3150	3550	2240	850
	560	2800	3350	3750	4250	4000	3550	3000	2800	3750	3350	3000	3000	3350	3350	3750	4000	2240	1320
<b>2 240 000</b>	560	2650	3150	3350	3750	3750	3350	2650	2500	3550	3000	2800	2800	2800	3000	3000	3350	2120	1180
	400	2800	3150	3550	3750	3750	3350	2800	2650	3350	3150	3000	2800	3150	3350	3750	3750	2120	1400
<b>2 800 000</b>	560	2360	2800	3150	3350	3550	3000	2500	2240	3150	2800	2500	2500	2500	2650	3000	3350	1900	1000
	400	2650	3000	3350	3550	3550	3000	2650	2500	3150	2800	2650	2650	2800	3150	3350	3350	2000	1320
<b>3 550 000</b>	560	2240	2500	2800	3150	3350	2800	2240	2120	3000	2650	2360	2360	2240	2360	2800	3000	1800	850
	400	2360	2800	3150	3350	3350	2800	2500	2240	3000	2650	2500	2500	2650	2800	3150	3150	1800	1180
<b>4 500 000</b>	560	2000	2240	2500	2800	3150	2650	2120	1900	2800	2360	2120	2120	2000	2120	2500	2800	1700	710
	400	2240	2500	3000	3150	3150	2650	2240	2120	2800	2500	2360	2360	2500	2650	2800	3000	1700	1060
<b>5 600 000</b>	560	1800	1900	2120	2500	2800	2360	1900	1700	2650	2240	2000	1800	1700	1900	2240	2500	1500	600
	400	2000	2360	2650	3000	2800	2500	2120	1900	2650	2360	2120	2120	2240	2360	2650	2800	1600	900
<b>max 5 600</b>																	<b>max 3 550</b>	<b>max 1 800</b>	

Werte gültig für langsamlaufende Vollwelle<sup>3)</sup> (s. Kap. 22).

Values valid for solid low speed shaft<sup>3)</sup> (see ch. 22).

Größe  
size **225**

<b>280 000</b>	1 600	6700	7100	7100	7100	7100	7100	7100	6300	7100	7100	7100	7100	7100	7100	7100	7100	4500	2240
	1 120	7100	7100	7100	7100	7100	7100	7100	7100	7100	7100	7100	7100	7100	7100	7100	7100	7100	4500
<b>355 000</b>	1 600	6300	7100	7100	7100	7100	7100	6300	5600	7100	7100	6700	6700	6700	7100	7100	7100	4500	2240
	1 120	6700	7100	7100	7100	7100	7100	6300	6300	7100	7100	7100	7100	7100	7100	7100	7100	4500	2240
<b>450 000</b>	1 600	5600	6700	7100	7100	7100	7100	6000	5300	7100	6700	6000	6000	6000	6300	7100	7100	4250	2000
	1 120	6300	7100	7100	7100	7100	7100	6300	6000	7100	7100	6300	6300	7100	7100	7100	7100	4500	2240
<b>560 000</b>	1 600	5300	5600	6300	7100	7100	6700	5300	4750	7100	6300	5600	5300	5000	5600	6300	7100	4000	1700
	1 120	5600	6700	7100	7100	7100	6700	6000	5300	7100	6300	6000	6000	6000	6300	7100	7100	4250	2240
<b>710 000</b>	1 600	4750	5000	5600	6700	7100	6300	4750	4250	6700	5600	5000	4500	4250	4750	5700	6300	3750	1320
	1 120	5300	6300	7100	7100	7100	6300	5300	5000	6700	6000	5600	5600	6000	6300	6700	7100	3750	2120
<b>900 000</b>	800	5600	6300	7100	7100	7100	6300	5600	5300	6700	6000	5600	5600	6000	6300	6700	7100	4000	2240
	1 600	4250	4250	5000	6000	6700	5600	4500	4000	6300	5300	4500	3750	3750	4250	5000	5700	3550	1120
<b>1 120 000</b>	1 120	4750	5600	6300	7100	7100	6000	5000	4500	6300	5600	5000	5000	5300	5600	6300	7100	3550	1900
	800	5300	6000	6700	7100	6700	6000	5300	5000	6300	5600	5300	5600	5600	6300	6700	6700	3750	2240
<b>1 400 000</b>	1 120	4500	5300	5600	6300	6700	5600	4500	4000	6000	5000	4750	4750	4750	5000	5600	6300	3350	1600
	800	4750	5600	6300	6700	6300	5600	5000	4500	6000	5300	5000	5000	5300	6000	6300	6300	3350	2240
<b>1 800 000</b>	1 120	4000	4500	5000	5600	6300	5000	4000	3750	5600	4750	4250	4250	4000	4500	5000	5600	3150	1400
	800	4500	5000	6000	6300	6000	5300	4500	4250	5600	5000	4500	4500	5000	5300	6000	6000	3350	2000
<b>2 240 000</b>	1 120	3750	4000	4500	5300	5600	4750	3750	3350	5300	4500	4000	3750	3550	4000	4500	5000	2800	1180
	800	4000	4750	5600	6000	5600	5000	4250	3750	5300	4500	4250	4250	4500	5000	5300	5600	3000	1700
<b>2 800 000</b>	800	3750	4500	5000	5600	5300	4500	3750	3550	4750	4250	3750	3750	4250	4500	5000	5300	2800	1500
	560	4000	4500	5000	5300	5300	4500	4000	3750	4750	4250	4000	4000	4250	4750	5000	5000	2800	2000
<b>3 550 000</b>	800	3350	4000	4500	5000	5000	4250	3550	3150	4500	4000	3550	3550	3750	4000	4500	5000	2500	1320
	560	3750	4250	4750	5000	4750	4250	3750	3550	4500	4000	3750	3750	4000	4500	4750	4750	2650	1700
<b>4 500 000</b>	800	3150	3750	4000	4500	4750	4000	3150	2800	4250	3550	3350	3350	3350	3550	4000	4500	2360	1120
	560	3350	3750	4500	4750	4500	4000	3350	3150	4250	3750	3550	3550	3550	3750	4250	4500	2360	1600
<b>5 600 000</b>	800	2800	3350	3550	4250	4500	3750	3000	2650	4000	3350	3000	3000	2800	3150	3550	4000	2240	1000
	560	3150	3550	4250	4500	4250	3750	3150	3000	4000	3550	3150	3150	3550	3750	4250	4250	2240	1400
<b>5 600 000</b>	800	2650	2800	3150	3750	4000	3350	2650	2360	3750	3150	2800	2650	2500	2800	3150	3550	2000	800
	560	2800	3350	4000	4250	4000	3350	3000	2650	3550	3150	3000	3000	3150	3550	3750	4000	2120	1250
<b>max 7 100 (max 4 000 bei «Kurzseite» für «short side»)</b>																	<b>max 4 500</b>	<b>max 2 240</b>	

1) Außer der Radialbelastung kann gleichzeitig eine Axialbelastung vorliegen, die das 0,2-fache der Tabellenwerte erreichen kann un umgekehrt. Bei höheren Werten bitte rückfragen.  
2) Eine ungünstige Belastungsrichtung kann  $F_{r2}$  zu  $0,8 \cdot F_{r2max}$  einschränken.  
3) Mit langsamlaufender Hollowwelle beträgt  $F_{r2}$  zulässig 0,4 mal den Tabellenwert.

1) An axial load of up to 0,2 times the value in the table is permissible, simultaneously with the radial load and vice versa. If exceeded consult us.  
2) An unfavourable direction of load can limit  $F_{r2}$  to  $0,8 \cdot F_{r2max}$ .  
3) A radial load 0,4 times the value in the table is permissible for hollow low speed shaft.

### 19 - Radial- $F_{r2}$ [daN] oder Axialbelastungen $F_{a2}$ [daN] auf dem langsamlaufenden Wellenende

Radialbelastung **an der Seite der Rille** ●.  
Bei Radialbelastungen gleichzeitig an beiden Seiten bitte rückfragen.

### 19 - Radial loads $F_{r2}$ [daN] or axial loads $F_{a2}$ [daN] on low speed shaft end

Applied radial load **groove side** ●.  
For radial loads acting simultaneously on both sides consult us.

Größe size **200**

$n_2 \cdot L_h$ min <sup>-1</sup> · h	$M_2$ daNm	$F_{r2}^{1)2)}$												$F_{a2}^{1)}$							
		0	45	90	135	180	225	270	315	0	45	90	135	180	225	270	315				
<b>280 000</b>	1 120	3750	5600	5600	5600	5600	5000	3350	3150	5600	4000	3750	4250	5600	5600	5600	5600	3550	1800		
	800	4750	5600	5600	5600	5600	5300	4250	4000	5600	4750	4500	4750	5600	5600	5600	5600	3550	1800		
<b>355 000</b>	1 120	3350	5300	5600	5600	5600	4500	3000	2800	5000	3750	3350	3750	5300	5600	5600	5600	3550	1700		
	800	4250	5600	5600	5600	5600	5000	3750	3550	5300	4250	4000	4500	5600	5600	5600	5600	3550	1800		
<b>450 000</b>	1 120	3000	5000	5600	5600	5600	4000	2650	2360	4750	3350	3000	3350	4500	5600	5600	5600	3350	1400		
	800	3750	5300	5600	5600	5600	4500	3550	3150	5000	4000	3550	4000	5000	5600	5600	5600	3350	1800		
<b>560 000</b>	1 120	2650	4500	5600	5600	5600	3550	2240	2000	4250	3000	2500	3000	4000	5300	5600	5600	3150	1180		
	800	3350	4750	5600	5600	5600	4250	3150	2800	4500	3550	3150	3550	4750	5600	5600	5600	3150	1800		
<b>710 000</b>	1 120	2240	4000	5600	5600	5600	3150	1900	1700	3750	2500	2240	2650	3350	4750	5600	5600	2800	950		
	800	3000	4500	5600	5600	5600	3750	2800	2500	4250	3150	2800	3350	4250	5600	5600	5600	3000	1600		
<b>900 000</b>	1 120	1900	3350	5000	5600	5300	2650	1600	1400	3550	2240	1900	2360	2800	4250	5300	5000	2650	750		
	800	2800	4250	5600	5600	5300	3550	2500	2240	4000	3000	2650	3000	4000	5000	5600	5300	2800	1400		
<b>1 120 000</b>	560	3350	4250	5600	5600	5000	3750	3000	2800	4000	3350	3150	3350	4250	5000	5600	5000	2800	1800		
	400	2500	3750	5300	5600	5000	3150	2120	2000	3550	2650	2360	2650	3750	4500	5300	5000	2500	1180		
<b>1 400 000</b>	800	2120	3550	4750	5300	4500	2800	1800	1700	3350	2360	2000	2360	3150	4250	4750	4750	2360	1000		
	560	2650	3750	4750	5300	4500	3150	2500	2240	3550	2800	2500	2800	3550	4500	5000	4500	2360	1500		
<b>1 800 000</b>	800	1800	3150	4250	5000	4250	2500	1600	1400	3000	2120	1800	2120	2800	3750	4500	4250	2240	850		
	560	2500	3350	4500	5000	4250	3000	2240	2000	3350	2500	2360	2650	3350	4250	4750	4250	2240	1320		
<b>2 240 000</b>	560	2240	3150	4250	4750	4000	2650	2000	1800	3000	2360	2120	2360	3150	3750	4250	4000	2120	1180		
	400	2500	3350	4000	4250	3750	3000	2360	2240	3150	2650	2360	2650	3150	3750	4250	3750	2120	1400		
<b>2 800 000</b>	560	2000	3000	4000	4500	3750	2500	1700	1600	2800	2120	1900	2120	2800	3550	4000	3750	1900	1000		
	400	2360	3000	3750	4000	3550	2650	2120	2000	2800	2360	2240	2360	3000	3550	4000	3550	2000	1320		
<b>3 550 000</b>	560	1700	2650	3750	4000	3550	2240	1500	1400	2500	1900	1600	1900	2650	3150	3750	3550	1800	850		
	400	2120	2800	3750	4000	3350	2500	1900	1800	2650	2120	2000	2240	2800	3350	3750	3350	1800	1180		
<b>4 500 000</b>	560	1500	2500	3350	3750	3150	2000	1320	1180	2360	1700	1500	1700	2360	3000	3350	3350	1700	710		
	400	1900	2650	3550	3750	3150	2240	1700	1600	2500	2000	1800	2000	2500	3150	3550	3150	1700	1060		
<b>5 600 000</b>	560	1320	2240	3000	3550	3000	1800	1120	1000	2120	1500	1250	1500	2000	2650	3150	3000	1500	600		
	400	1700	2360	3350	3550	3000	2120	1500	1400	2360	1800	1600	1800	2360	3000	3350	3000	1600	900		
<b>max 5 600</b>																		<b>max 3 550</b>		<b>max 1 800</b>	

Werte gültig für langsamlaufende Vollwelle<sup>3)</sup> (s. Kap. 22).

Values valid for solid low speed shaft<sup>3)</sup> (see ch. 22).

Größe size **225**

<b>280 000</b>	1 600	5600	7100	7100	7100	7100	7100	5300	4750	7100	6000	5600	6300	7100	7100	7100	7100	4500	2240		
	1 120	6700	7100	7100	7100	7100	7100	6300	6000	7100	6700	6300	6700	7100	7100	7100	7100	4500	2240		
<b>355 000</b>	1 600	5000	7100	7100	7100	7100	6300	4500	4250	7100	5600	5000	5600	7100	7100	7100	7100	4500	2240		
	1 120	6000	7100	7100	7100	7100	7100	5600	5300	7100	6300	5600	6300	7100	7100	7100	7100	4500	2240		
<b>450 000</b>	1 600	4500	7100	7100	7100	7100	6000	4000	3750	6700	5000	4500	5000	6700	7100	7100	7100	4250	2000		
	1 120	5600	7100	7100	7100	7100	6700	5000	4750	7100	5600	5300	5600	7100	7100	7100	7100	4500	2240		
<b>560 000</b>	1 600	4000	6300	7100	7100	7100	5300	3550	3150	6300	4500	4000	4500	6000	7100	7100	7100	4000	1700		
	1 120	5000	6700	7100	7100	7100	6000	4500	4250	6700	5300	4750	5300	6700	7100	7100	7100	4250	2240		
<b>710 000</b>	1 600	3550	5600	7100	7100	7100	4750	3000	2650	5600	4000	3350	4000	5000	6700	7100	7100	3750	1320		
	1 120	4500	6300	7100	7100	7100	5600	4000	3750	6000	4750	4250	4750	6300	7100	7100	7100	3750	2120		
<b>900 000</b>	800	5000	6300	7100	7100	7100	6000	4750	4500	6300	5300	5000	5300	6300	7100	7100	7100	4000	2240		
	1 600	3000	5000	7100	7100	7100	4250	2650	2360	5300	3550	3000	3550	4500	6000	7100	7100	3550	1120		
<b>1 120 000</b>	1 120	4000	6000	7100	7100	7100	5000	3750	3350	5600	4250	4000	4250	5600	7100	7100	7100	3550	1900		
	800	4750	6000	7100	7100	7100	5600	4500	4250	5600	4750	4500	5000	6000	7100	7100	7100	3750	2240		
<b>1 400 000</b>	1 120	3550	5300	7100	7100	6700	4500	3350	3000	5300	4000	3550	4000	5300	6300	7100	7100	3350	1600		
	800	4250	5600	7100	7100	6700	5000	4000	3750	5300	4500	4000	4500	5600	6700	7100	6700	3350	2240		
<b>1 800 000</b>	1 120	3150	5000	6700	7100	6300	4000	2800	2500	4750	3550	3150	3550	4750	5600	6700	6700	3150	1400		
	800	3750	5300	6700	7100	6300	4750	3550	3350	5000	4000	3750	4000	5000	6300	6700	6300	3350	2000		
<b>2 240 000</b>	1 120	2800	4500	6000	7100	6000	3750	2500	2240	4500	3150	2800	3150	4000	5300	6300	6000	2800	1180		
	800	3550	4750	6300	6700	5600	4250	3150	3000	4500	3750	3350	3750	4750	6000	6300	6000	3000	1700		
<b>2 800 000</b>	800	3150	4500	6000	6300	5600	4000	3000	2650	4250	3350	3150	3350	4250	5600	6000	5600	2800	1500		
	560	3750	4500	5600	6000	5300	4250	3550	3350	4500	3750	3550	3750	4500	5300	5600	5300	2800	2000		
<b>2 800 000</b>	800	2800	4000	5600	6300	5000	3550	2650	2360	4000	3000	2800	3150	4000	5000	5600	5300	2500	1320		
	560	3350	4250	5300	5600	5000	3750	3150	3000	4000	3350	3150	3550	4250	5000	5300	5000	2650	1700		
<b>3 550 000</b>	800	2500	3750	5300	5600	4750	3150	2240	2120	3750	2800	2500	2800	3750	4500	5000	5000	2360	1120		
	560	3000	4000	5000	5300	4750	3550	2800	2650	3750	3150	2800	3150	3750	4750	5000	4750	2360	1600		
<b>4 500 000</b>	800	2240	3550	4750	5300	4500	3000	2000	1800	3350	2500	2240	2500	3350	4250	4750	4750	2240	1000		
	560	2800	3750	4750	5000	4500	3350	2500	2360	3550	2800	2650	2800	3550	4500	4750	4500	2240	1400		
<b>5 600 000</b>	800	2000	3150	4250	5000	4250	2650	1800	1600	3150	2240	1900	2240	2800	3750	4250	4250	2000	800		
	560	2500	3350	4500	4750	4000	3000	2360	2120	3350	2650	2360	2650	3350	4250	4500	4250	2120	1250		
<b>max 7 100 (max 4 000 bei «Kurzseite» für «short side»)</b>																		<b>max 4 500</b>		<b>max 2 240</b>	

1) Außer der Radialbelastung kann gleichzeitig eine Axialbelastung vorliegen, die das 0,2-fache der Tabellenwerte erreichen kann umgekehrt. Bei höheren Werten bitte rückfragen.  
 2) Eine ungünstige Belastungsrichtung kann  $F_{r2}$  zu  $0,8 \cdot F_{r2max}$  einschränken.  
 3) Mit langsamlaufender Hohlwelle beträgt  $F_{r2}$  zulässig 0,4 mal den Tabellenwert.

1) An axial load of up to 0,2 times the value in the table is permissible, simultaneously with the radial load and vice versa. If exceeded consult us.  
 2) An unfavourable direction of load can limit  $F_{r2}$  to  $0,8 \cdot F_{r2max}$ .  
 3) A radial load 0,4 times the value in the table is permissible for hollow low speed shaft.

**19 - Radial- $F_{r2}$  [daN] oder Axialbelastungen  $F_{a2}$  [daN] auf dem langsamlaufenden Wellenende**

Radialbelastung **an der Gegenseite der Rille.**  
Bei Radialbelastungen gleichzeitig an beiden Seiten bitte rückfragen.

**19 - Radial loads  $F_{r2}$  [daN] or axial loads  $F_{a2}$  [daN] on low speed shaft end**

Applied radial load **opposite side to groove.**  
For radial loads acting simultaneously on both sides consult us.

Größe size **250**

$n_2 \cdot L_h$ min <sup>-1</sup> · h	$M_2$ daN m	$F_{r2}$ 1) 2)																$F_{a2}$ 1)	
		0	45	90	135	180	225	270	315	0	45	90	135	180	225	270	315		
<b>280 000</b>	2 240	9000	9000	9000	9000	9000	9000	9000	9000	8500	8000	8500	9000	9000	9000	9000	9000	2800	5600
	1 600	9000	9000	9000	9000	9000	9000	9000	9000	9000	8500	9000	9000	9000	9000	9000	9000	2800	5600
<b>355 000</b>	2 240	9000	9000	9000	9000	8500	8000	8000	9000	7500	7100	8000	9000	9000	9000	9000	9000	2800	5600
	1 600	9000	9000	9000	9000	9000	8500	8500	9000	8500	8000	8500	9000	9000	9000	9000	9000	2800	5600
<b>450 000</b>	2 240	9000	9000	9000	8000	7500	7500	7500	8500	7100	6700	7100	9000	9000	9000	9000	8500	2800	5600
	1 600	9000	9000	9000	9000	8500	8000	8000	8500	7500	7100	8000	9000	9000	9000	9000	9000	2800	5600
<b>560 000</b>	2 240	9000	9000	8000	7100	6300	6700	6700	7500	6300	6000	6700	8500	9000	9000	8000	7100	2500	5300
	1 600	9000	9000	9000	8500	8000	7100	7100	8000	7100	6700	7100	8500	9000	9000	9000	8000	2800	5600
<b>710 000</b>	2 240	8500	8000	7100	6000	5600	6000	6300	7100	6000	5300	6000	7500	9000	8000	7100	6300	2120	5000
	1 600	8500	9000	8500	7500	7100	6700	6700	7500	6300	6300	6700	8000	9000	9000	8500	7500	2800	5300
	1 120	8000	8500	8500	8000	7500	7100	7100	7500	6700	6700	7100	8000	9000	9000	8500	7500	2800	5300
<b>900 000</b>	2 240	8000	7100	6300	5300	4750	5000	5600	6700	5300	5000	5600	7100	8000	7500	6300	5000	1700	4750
	1 600	7500	8500	7500	7100	6700	6300	6300	6700	6000	5600	6000	7100	8500	8500	8000	7100	2650	4750
	1 120	7500	8000	8000	7500	7100	6700	6700	7100	6300	6000	6000	6700	7500	7500	7100	7100	2800	4750
<b>1 120 000</b>	1 600	7100	7500	7100	6300	6000	5600	5600	6300	5300	5300	5600	6300	7500	8000	7100	6300	2360	4500
	1 120	7100	7500	7500	7100	6300	6000	6000	6300	6000	5600	6000	6700	7500	8000	7500	6700	2800	4500
	800	6700	7100	6300	5600	5300	5300	5300	6000	5000	4750	5300	6300	7500	7100	6300	6000	2120	4000
<b>1 400 000</b>	1 600	6300	6300	5600	5000	4750	4750	5000	5300	4500	4250	4750	5600	6000	6000	6700	6700	1800	3750
	1 120	6300	6700	6700	6000	5600	5300	5300	5600	5000	4750	5000	6000	6700	7100	6700	5600	2500	4000
	800	6000	6300	6000	5300	5300	4750	4750	5300	4500	4500	4750	5600	6300	6700	6300	5300	2240	3550
<b>2 240 000</b>	1 120	5300	6000	5300	5000	4750	4500	4500	4750	4250	4000	4250	5300	6000	6000	5600	5000	1900	3350
	800	5300	5600	5600	5300	5000	4750	4750	5000	4500	4250	4750	5300	6000	6000	5600	5000	2360	3550
	600	5000	5300	5000	4500	4250	4000	4000	4500	3750	3550	4000	4750	5600	5600	5000	4500	1700	3150
<b>3 550 000</b>	1 120	5000	5300	5300	5000	4500	4250	4250	4750	4250	4000	4250	5300	5600	5600	5300	4750	2240	3150
	800	5000	5300	5300	5000	4500	4250	4250	4750	4250	4000	4250	5300	5600	5600	5300	4750	2240	3150
	600	4750	5000	5000	4500	4000	3750	3750	4250	3750	3550	3750	4500	5300	5000	4500	4250	1500	3000
<b>4 500 000</b>	1 120	4750	5000	5000	4750	4250	4000	4000	4250	3750	3550	3750	4500	5300	5000	4500	4250	2000	3000
	800	4750	5000	5000	4750	4250	4000	4000	4250	3750	3550	3750	4500	5300	5000	4500	4250	2000	3000
	600	4500	4500	4000	3550	3150	3350	3350	3750	3150	3000	3350	4250	5000	4500	4000	3550	1250	2650
	800	4500	4750	4750	4250	4000	3550	3550	4000	3550	3350	3550	4250	4750	5000	4750	4000	1800	2800
																		<b>max 9 000</b>	<b>max 2 800</b>

Werte gültig für langsamlaufende Vollwelle<sup>3)</sup> (s. Kap. 22).

Values valid for solid low speed shaft<sup>3)</sup> (see ch. 22).

Größe size **280**

$n_2 \cdot L_h$ min <sup>-1</sup> · h	$M_2$ daN m	$F_{r2}$ 1) 2)																$F_{a2}$ 1)	
		0	45	90	135	180	225	270	315	0	45	90	135	180	225	270	315		
<b>280 000</b>	3 150	11200	11200	11200	11200	11200	11200	11200	11200	11200	10600	11200	11200	11200	11200	11200	11200	3550	7100
	2 240	11200	11200	11200	11200	11200	11200	11200	11200	11200	11200	11200	11200	11200	11200	11200	11200	3550	7100
<b>355 000</b>	3 150	11200	11200	11200	11200	11200	10600	10600	11200	10000	9500	10600	11200	11200	11200	11200	11200	3550	7100
	2 240	11200	11200	11200	11200	11200	11200	11200	11200	11200	10600	11200	11200	11200	11200	11200	11200	3550	7100
<b>450 000</b>	3 150	11200	11200	11200	11200	10600	10000	10000	10600	9500	9000	9500	11200	11200	11200	11200	11200	3550	7100
	2 240	11200	11200	11200	11200	10600	10600	11200	11200	10000	9500	10600	11200	11200	11200	11200	11200	3550	7100
<b>560 000</b>	3 150	11200	11200	11200	10000	9500	9000	9000	10000	8500	8000	8500	10600	11200	11200	11200	10000	3350	6700
	2 240	11200	11200	11200	11200	10600	9500	9500	10600	9500	9000	9500	11200	11200	11200	10600	10600	3550	6700
<b>710 000</b>	3 150	11200	11200	10000	9000	8000	8500	8000	9000	8000	7100	8000	10000	11200	11200	10000	9000	2800	6000
	2 240	10600	11200	11200	10600	10000	9000	9000	9500	8500	8000	8500	10000	11200	11200	11200	10000	3550	6300
	1 600	10600	11200	11200	11200	10000	9500	9500	10000	9000	9000	9500	10600	11200	11200	11200	10000	3550	6300
<b>900 000</b>	3 150	10000	10000	9000	7500	7100	7500	7500	8500	7100	6300	7100	9500	11200	10600	9000	8000	2360	5600
	2 240	10000	11200	10600	10000	9000	8000	8000	9000	8000	7500	8000	9500	11200	11200	11200	9500	3550	6000
	1 600	10000	10600	10600	10000	9500	8500	8500	9000	8500	8000	8500	9500	11200	11200	10600	9500	3550	6000
<b>1 120 000</b>	2 240	9500	10600	9500	9000	8500	7500	7500	8000	7100	6700	7500	9000	10600	11200	10000	8500	3150	5600
	1 600	9500	10000	10000	9500	8500	8000	8000	8500	8000	7500	8000	9000	10000	10600	10000	9000	3550	5600
	1000	9000	9500	8500	8000	7500	7100	6700	7500	6700	6300	6700	8000	9000	9500	9000	8000	2650	5000
<b>1 400 000</b>	2 240	9000	9500	8500	8000	7500	7100	6700	7500	6700	6300	6700	8000	10000	10000	9000	8000	2650	5000
	1 600	9000	10000	9000	8500	8000	7100	7100	7500	7100	6700	7100	8500	9500	10000	9500	8000	3550	5300
	1000	8500	8500	8000	7100	6300	6300	6300	7100	6000	5600	6300	7500	9500	9000	8000	7100	2360	4750
<b>2 240 000</b>	1 600	8000	9000	9000	8500	7500	6700	6700	7500	6700	6300	6700	8000	9000	9500	9000	7500	3150	4750
	1 120	7500	8500	8500	7500	7100	6300	6300	6700	6300	5600	5600	6700	8000	8500	8500	7100	2800	4500
	800	7500	8000	8000	7500	7100	6300	6300	6700	6300	6000	6000	6700	7500	8000	8000	7100	3350	4500
<b>2 800 000</b>	1 600	7100	8000	7500	6700	6300	5600	5600	6300	5600	5300	5600	6700	8000	8500	7500	6700	2500	4250
	1 120	7100	7500	7500	7100	6700	6000	6000	6300	6000	5600	6000	6700	7500	8000	7500	6700	3150	4250
	800	6000	6300	6300	5600	5300	5000	5000	5300	5000	4750	5000	6000	6700	7100	6700	6000	2500	3750
<b>3 550 000</b>	1 600	6700	7500	6700	6300	6000	5300	5300	5600	5000	4750	5300	6300	7500	7500	7100	6300	2240	3750
	1 120	6700	7100	7100	6700	6000	5600	5600	6000	6000	5600	6000	6700	7500	7500	7100	6300	2800	4000
	800	6300	6700	6700	6300	5600	5300	5300	5600	5000	4750	5000	6000						



19 - Radial- $F_{r2}$  [daN] oder Axialbelastungen  $F_{a2}$  [daN] auf dem langsamlaufenden Wellenende

Radialbelastung **an der Seite der Rille** ●.

Bei Radialbelastungen gleichzeitig an beiden Seiten bitte rückfragen.

19 - Radial loads  $F_{r2}$  [daN] or axial loads  $F_{a2}$  [daN] on low speed shaft end

Applied radial load **groove side** ●.

For radial loads acting simultaneously on both sides consult us.

Größe size **250**

$n_2 \cdot L_h$  min <sup>-1</sup> · h	$M_2$  daN m	$F_{r2}^{1) 2)}$																$F_{a2}^{1)}$		
		0	45	90	135	180	225	270	315	0	45	90	135	180	225	270	315			
<b>280 000</b>	2 240	9000	9000	9000	9000	9000	7500	6700	7500	7100	6000	6300	8500	9000	9000	9000	9000	2800	5600	
	1 600	9000	9000	9000	9000	9000	8500	7500	8500	8000	7100	7500	9000	9000	9000	9000	9000	2800	5600	
<b>355 000</b>	2 240	9000	9000	9000	9000	9000	6700	6000	6700	6300	5000	5600	7500	9000	9000	9000	9000	2800	5600	
	1 600	9000	9000	9000	9000	9000	7500	7100	7500	7500	6300	6700	8500	9000	9000	9000	9000	2800	5600	
<b>450 000</b>	2 240	8000	9000	9000	9000	8500	6000	5300	6000	5600	4500	5000	7100	9000	9000	9000	8500	2800	5600	
	1 600	8500	9000	9000	9000	9000	7100	6300	7100	6700	6000	6300	8000	9000	9000	9000	9000	2800	5600	
<b>560 000</b>	2 240	7500	9000	9000	9000	7500	5300	4750	5300	5000	3750	4250	6300	9000	9000	9000	8000	2500	5300	
	1 600	8000	9000	9000	9000	8000	6300	4750	6300	6000	5300	5600	7100	9000	9000	9000	8500	2800	5600	
<b>710 000</b>	2 240	6700	9000	9000	8500	6700	4750	4250	4750	4250	3350	3550	5600	9000	9000	9000	7100	2120	5000	
	1 600	7100	9000	9000	9000	7500	6000	5300	5600	5600	4750	5000	6700	9000	9000	9000	7500	2800	5300	
	1 120	7500	9000	9000	9000	7500	6300	6000	6300	6300	5600	6000	7100	9000	9000	9000	8000	2800	5300	
<b>900 000</b>	2 240	6300	9000	9000	8000	5600	4250	3550	4250	3550	2800	3150	5000	9000	9000	9000	6300	1700	4750	
	1 600	6700	9000	9000	9000	7100	5300	4750	5300	5000	4250	4500	6000	9000	9000	9000	7100	2650	4750	
	1 120	7100	8500	9000	8500	7100	6000	5300	6000	5600	5000	5300	6700	8500	9000	9000	7100	2800	4750	
<b>1 120 000</b>	1 600	6300	8500	9000	8000	6300	4750	4250	4750	4500	3750	4000	5600	8500	9000	9000	6700	2360	4500	
	1 120	6700	8000	9000	8000	6700	5300	5000	5300	5300	4750	5000	6000	8000	9000	8500	6700	2800	4500	
<b>1 400 000</b>	1 600	5600	8000	8500	7500	6000	4250	3750	4250	4000	3150	3550	5000	7500	9000	8500	6000	2120	4000	
	1 120	6000	7500	8000	7500	6300	5000	4500	5000	4750	4000	4500	5600	7500	8500	8000	6300	2650	4250	
<b>1 800 000</b>	1 600	5300	7500	7500	6700	5300	3750	3350	3750	3550	2800	3000	4500	7100	8500	7500	5600	1800	3750	
	1 120	5600	7100	7500	7100	5600	4750	4000	4500	4250	3750	4000	5300	7100	8000	7500	6000	2500	4000	
<b>2 240 000</b>	1 120	5300	6700	7500	6700	5300	4250	3750	4000	4000	3350	3550	4750	6700	8000	7100	5300	2240	3550	
	800	5300	6300	6700	6300	5300	4750	4250	4500	4500	4000	4250	5000	6300	7100	6700	5600	2650	3750	
<b>2 800 000</b>	1 120	4750	6300	7100	6300	5000	3750	3350	3750	3550	3000	3150	4250	6300	7500	6700	5000	1900	3350	
	800	5000	6000	6300	6000	5000	4250	3750	4250	4000	3750	3750	4750	6000	6700	6300	5300	2360	3550	
<b>3 550 000</b>	1 120	4500	6000	6300	5600	4500	3350	3000	3350	3150	2650	2800	4000	6000	7100	6300	4750	1700	3150	
	800	4750	5600	6300	5600	4750	3750	3550	3750	3750	3150	3150	4250	5600	6300	6000	4750	2240	3150	
<b>4 500 000</b>	1 120	4000	5600	6000	5300	4250	3000	2650	3000	2800	2240	2500	3550	5300	6700	6000	4250	1500	3000	
	800	4250	5300	6000	5300	4500	3550	3150	3550	3350	3000	3150	4000	5300	6000	5600	4500	2000	3000	
<b>5 600 000</b>	1 120	3750	5300	5300	4750	3750	2650	2360	2650	2500	2000	2120	3150	5000	6300	5300	4000	1250	2650	
	800	4000	5000	5600	5000	4000	3150	3000	3150	3000	2650	2800	3550	5000	6000	5300	4250	1800	2800	
max <b>9 000</b>																			max <b>2 800</b>	max <b>5 600</b>

Werte gültig für langsamlaufende Vollwelle<sup>3)</sup> (s. Kap. 22).

Values valid for solid low speed shaft<sup>3)</sup> (see ch. 22).

Größe size **280**

	$n_2 \cdot L_h$  min <sup>-1</sup> · h	$M_2$  daN m	$F_{r2}$																$F_{a2}$	
			0	45	90	135	180	225	270	315	0	45	90	135	180	225	270	315		
<b>280 000</b>	3 150	11200	11200	11200	11200	11200	10000	9000	10000	9500	8000	8500	11200	11200	11200	11200	11200	3550	7100	
	2 240	11200	11200	11200	11200	11200	11200	10600	11200	11200	9500	10000	11200	11200	11200	11200	11200	3550	7100	
<b>355 000</b>	3 150	11200	11200	11200	11200	11200	9000	8000	9000	8500	7100	7500	10600	11200	11200	11200	11200	3550	7100	
	2 240	11200	11200	11200	11200	11200	10000	9500	10000	10000	8500	9000	11200	11200	11200	11200	11200	3550	7100	
<b>450 000</b>	3 150	10600	11200	11200	11200	11200	8000	7100	8000	7500	6300	6700	9500	11200	11200	11200	11200	3550	7100	
	2 240	11200	11200	11200	11200	11200	9500	8500	9000	9000	8000	8500	10600	11200	11200	11200	11200	3550	7100	
<b>560 000</b>	3 150	10000	11200	11200	11200	10600	7500	6300	7100	6700	5300	5600	8500	11200	11200	11200	10600	3350	6700	
	2 240	10600	11200	11200	11200	10600	8500	7500	8500	8000	7100	7500	9500	11200	11200	11200	11200	3550	6700	
<b>710 000</b>	3 150	9000	11200	11200	11200	9500	6700	5600	6300	6000	4500	5000	7500	11200	11200	11200	9500	2800	6000	
	2 240	9500	11200	11200	11200	10000	8000	7100	7500	7500	6300	6700	9000	11200	11200	11200	10600	3550	6300	
	1 600	10000	11200	11200	11200	10000	8500	8000	8500	8500	7500	8000	9500	11200	11200	11200	10600	3550	6300	
<b>900 000</b>	3 150	8000	11200	11200	11200	8000	5600	5000	5600	5000	4000	4250	6700	11200	11200	11200	9000	2360	5600	
	2 240	9000	11200	11200	11200	9500	7100	6300	6700	6700	5600	6000	8000	11200	11200	11200	9500	3550	6000	
	1 600	9500	11200	11200	11200	9500	8000	7500	8000	8000	6700	7100	9000	11200	11200	11200	10000	3550	6000	
<b>1 120 000</b>	2 240	8500	11200	11200	11200	8500	6300	5600	6300	6000	5000	5300	7500	10600	11200	11200	9000	3150	5600	
	1 600	8500	10600	11200	10600	9000	7500	6700	7100	7100	6300	6700	8000	10600	11200	11200	9000	3550	5600	
<b>1 400 000</b>	2 240	7500	10600	11200	10000	8000	5600	5000	5600	5300	4250	4750	6700	10000	11200	11200	8000	2650	5000	
	1 600	7500	10000	11200	10600	8000	6000	5300	6000	6000	5000	5300	7500	10000	11200	10600	8500	3550	5300	
<b>1 800 000</b>	2 240	7100	10000	10600	9500	7500	5300	4500	5000	4750	3750	4000	6000	9500	11200	10600	7500	2360	4750	
	1 600	7500	9500	10600	9500	7500	6000	5600	6000	5600	5000	5300	6700	9500	11200	10000	8000	3150	4750	
<b>2 240 000</b>	1 600	6700	9000	10000	9000	7100	5600	5000	5300	5300	4500	4750	6300	8500	10600	9500	7500	2800	4500	
	1 120	7100	8500	9000	8500	7500	6300	5600	6000	6000	5000	5300	6700	8500	9500	9000	7500	3350	4500	
<b>2 800 000</b>	1 600	6300	8000	9500	8500	6700	5000	4500	5000	4750	4000	4250	5600	8000	10000	9000	6700	2500	4250	
	1 120	6700	8000	8500	8000	6700	5600	5000	5600	5600	4750	5000	6300	8000	9000	8500	6700	3150	4250	
<b>3 550 000</b>	1 600	6000	8000	8500	8000	6000	4500	4000	4500	4250	3550	3750	5300	7500	9500	8500	6300	2240	3750	
	1 120	6000	7500	8000	7500	6300	5000	4750	5000	5000	4250	4500	5600	7500	8500	8000	6300	2800	4000	
<b>4 500 000</b>	1 600	5300	7500	8000	7100	5600	4000	3550	4000	3750	3150	3350	4750	7100	9000	8000	5600	1900	3550	
	1 120	5600	7100	7500	7100	6000	4750	4250	4750	4500	4000	4250	5300	7100	8000	7500	6000	2500	3750	
<b>5 600 000</b>	1 600	5000	7100	7500	6700															

19 - Radial- $F_{r2}$  [daN] oder Axialbelastungen  $F_{a2}$  [daN] auf dem langsamlaufenden Wellenende

Radialbelastung an der Gegenseite der Rille.

Bei Radialbelastungen gleichzeitig an beiden Seiten bitte rückfragen.

19 - Radial loads  $F_{r2}$  [daN] or axial loads  $F_{a2}$  [daN] on low speed shaft end

Applied radial load opposite side to groove.

For radial loads acting simultaneously on both sides consult us.

Größe size **320, 321**

$n_2 \cdot L_h$  min <sup>-1</sup> · h	$M_2$  daN m	$F_{r2}$ <sup>1) 2)</sup>														$F_{a2}$ <sup>1)</sup>			
		0	45	90	135	180	225	270	315	0	45	90	135	180	225	270	315		
280 000	4 500	13200	14000	14000	14000	14000	14000	13200	11800	14000	14000	13200	13200	14000	14000	14000	14000	9000	4500
	3 150	14000	14000	14000	14000	14000	14000	14000	13200	14000	14000	14000	14000	14000	14000	14000	14000	9000	4500
355 000	4 500	11800	14000	14000	14000	14000	14000	11800	11200	14000	13200	12500	12500	13200	13200	14000	14000	8500	4500
	3 150	13200	14000	14000	14000	14000	14000	13200	12500	14000	14000	13200	13200	14000	14000	14000	14000	9000	4500
450 000	4 500	10600	12500	14000	14000	14000	14000	11200	10000	14000	12500	11200	11800	11200	12500	14000	14000	8000	3750
	3 150	11800	14000	14000	14000	14000	14000	11800	11200	14000	13200	12500	12500	13200	14000	14000	14000	8500	4500
560 000	4 500	10000	11200	11800	14000	14000	12500	10000	9000	14000	11800	10600	10600	10000	10600	12500	14000	7500	3150
	3 150	11200	12500	14000	14000	14000	13200	11200	10600	14000	11800	11200	11200	12500	13200	14000	14000	7500	4500
710 000	4 500	9000	9500	10600	12500	13200	11800	9000	8000	13200	10600	9500	9000	8500	9500	11200	12500	6700	2500
	3 150	10000	11800	13200	14000	14000	11800	10000	9500	12500	11200	10600	10600	11200	11800	13200	14000	7100	4250
	2 240	10600	11800	13200	14000	14000	11800	10600	10000	12500	11800	10600	11200	11800	12500	13200	13200	7500	4500
900 000	4 500	8000	8000	9500	11200	12500	11200	8500	7500	11800	10000	8500	7500	7100	8000	9500	11200	6300	2000
	3 150	9000	11200	12500	13200	13200	11200	9500	8500	11800	10600	9500	9500	10600	10600	11800	13200	6700	3750
	2 240	10000	11200	12500	13200	13200	11200	10000	9500	11800	10600	10000	10000	11200	11800	12500	12500	6700	4500
1 120 000	3 150	8500	10000	11200	12500	12500	10600	8500	8000	11200	9500	9000	9000	9500	10000	10600	11800	6000	3150
	2 240	9000	10600	11800	12500	11800	10600	9000	8500	11200	10000	9500	9500	10000	11200	11800	11800	6300	4250
	1 600	7500	9000	9500	11200	11800	11800	9500	8000	10600	9000	8000	8000	8000	8500	9500	10600	5600	2650
1 400 000	3 150	8500	9500	11200	11800	11200	10000	8500	8000	10000	9000	8500	8500	9500	10600	11200	11200	6000	3750
	2 240	7500	9000	9500	11200	11800	11200	10000	8500	10000	9000	8500	8500	9500	10600	11200	11200	6000	4250
	1 600	7100	8000	8500	10000	10600	9000	7100	6300	9500	8000	7500	7500	7100	7500	9000	10000	5300	2240
2 240 000	2 240	7100	8500	9500	10600	10000	8500	7100	6700	9000	8000	7500	7500	8000	8500	9500	10000	5000	3000
	1 600	7500	8500	9500	10000	9500	8500	7500	7100	9000	8000	7500	7500	8500	9000	9500	9500	5300	3750
	1 120	6300	7500	8500	9500	9500	8000	6700	6000	8500	7500	6700	6700	7500	7500	8500	9500	4750	2500
2 800 000	2 240	7100	8000	9000	9500	9000	8000	7100	6700	8500	7500	7100	7100	7500	8500	9000	9000	4750	2500
	1 600	7100	8000	9000	9500	9000	8000	7100	6700	8500	7500	7100	7100	7500	8500	9000	9000	4750	3350
	1 120	6000	7100	7500	8500	9000	7500	6000	5600	8000	6700	6300	6300	6300	6700	7500	8500	4250	2240
3 550 000	2 240	6300	7500	8500	9000	8500	7500	6700	6300	8000	7100	6700	6700	7100	8000	8500	8500	4500	3000
	1 600	6300	7500	8500	9000	8500	7500	6700	6300	8000	7100	6700	6700	7100	8000	8500	8500	4500	3000
	1 120	5600	6300	6700	7500	8500	6700	5600	5000	7500	6300	5600	5600	5600	6000	6700	7500	4000	1900
4 500 000	2 240	6000	6700	8000	8500	8000	7100	6000	5600	7500	6700	6000	6300	6700	7500	8000	8000	4250	2650
	1 600	6000	6700	8000	8500	8000	7100	6000	5600	7500	6700	6000	6300	6700	7500	8000	8000	4250	2650
	1 120	5000	5600	6000	7100	7500	6300	5000	4500	6700	5600	5300	5300	5000	5300	6300	6700	3750	1600
5 600 000	2 240	5600	6300	7500	8000	7500	6300	5600	5300	6700	6000	5600	5600	6300	6700	7100	7500	3750	2360
	1 600	5600	6300	7500	8000	7500	6300	5600	5300	6700	6000	5600	5600	6300	6700	7100	7500	3750	2360
	1 120																		

max 14 000

max 9 000 max 4 500

Werte gültig für langsamlaufende Vollwelle<sup>3)</sup> (s. Kap. 22).

Values valid for solid low speed shaft<sup>3)</sup> (see ch. 22).

Größe size **360**

280 000	6 300	18000	18000	18000	18000	18000	18000	17000	18000	18000	18000	18000	18000	18000	18000	18000	18000	11200	5600
	4 500	18000	18000	18000	18000	18000	18000	18000	18000	18000	18000	18000	18000	18000	18000	18000	18000	11200	5600
355 000	6 300	16000	18000	18000	18000	18000	18000	16000	15000	18000	18000	17000	17000	18000	18000	18000	18000	11200	5600
	4 500	17000	18000	18000	18000	18000	18000	18000	17000	18000	18000	18000	18000	18000	18000	18000	18000	11200	5600
450 000	6 300	15000	18000	18000	18000	18000	18000	15000	14000	18000	17000	15000	16000	17000	18000	18000	18000	11200	5600
	4 500	16000	18000	18000	18000	18000	18000	16000	15000	18000	18000	16000	17000	18000	18000	18000	18000	11200	5600
560 000	6 300	13200	16000	18000	18000	18000	17000	14000	12500	18000	16000	14000	14000	14000	16000	18000	18000	10600	5000
	4 500	15000	17000	18000	18000	18000	18000	15000	14000	18000	16000	15000	15000	17000	18000	18000	18000	10600	5600
710 000	6 300	12500	14000	16000	18000	18000	16000	12500	11200	17000	14000	13200	13200	12500	14000	16000	18000	9500	4250
	4 500	13200	16000	18000	18000	18000	16000	14000	12500	17000	15000	14000	14000	15000	17000	18000	18000	10000	5600
	3 150	14000	16000	18000	18000	18000	16000	15000	14000	17000	16000	15000	15000	16000	17000	18000	18000	10600	5600
900 000	6 300	11200	12500	14000	16000	18000	15000	11200	10000	16000	13200	11800	11800	11200	12500	14000	16000	9000	3550
	4 500	12500	15000	17000	18000	18000	15000	12500	11800	16000	14000	13200	13200	14000	15000	17000	18000	9500	5600
	3 150	13200	15000	17000	18000	17000	15000	13200	13200	16000	14000	14000	14000	15000	16000	17000	17000	9500	5600
1 120 000	4 500	11200	14000	16000	17000	17000	14000	11800	10600	15000	13200	11800	11800	13200	14000	15000	17000	8500	4750
	3 150	12500	14000	16000	17000	16000	14000	12500	11800	15000	13200	12500	12500	14000	15000	16000	16000	9000	5600
	2 240	10600	12500	14000	16000	16000	13200	10600	9500	14000	11800	10600	11200	11800	12500	14000	15000	8000	4000
1 400 000	4 500	11200	13200	15000	16000	15000	13200	11800	10600	14000	12500	11800	11800	12500	14000	15000	15000	8000	5600
	3 150	11200	13200	15000	16000	15000	13200	11800	10600	14000	12500	11800	11800	12500	14000	15000	15000	8000	5600
	2 240	9500	11200	12500	14000	15000	12500	9500	9000	13200	11200	10000	10000	10000	11200	12500	14000	7500	3550
2 240 000	4 500	10600	12500	14000	15000	14000	12500	10600	10000	13200	11800	10600	10600	11800	13200	14000	14000	7500	5000
	3 150	10600	12500	14000	15000	14000	12500	10600	10000	13200	11800	10600	10600	11800	13200	14000	14000	7500	5000
	2 240	9500	11200	12500	14000	13200	11												

# 19 - Radial- $F_{r2}$ [daN] oder Axialbelastungen $F_{a2}$ [daN] auf dem langsamlaufenden Wellenende

Radialbelastung an der Seite der Rille ●  
Bei Radialbelastungen gleichzeitig an beiden Seiten bitte rückfragen.

# 19 - Radial loads $F_{r2}$ [daN] or axial loads $F_{a2}$ [daN] on low speed shaft end

Applied radial load **groove side** ●  
For radial loads acting simultaneously on both sides consult us.

Größe size **320, 321**

$n_2 \cdot L_h$ min <sup>-1</sup> · h	$M_2$ daN m	$F_{r2}^{1)2)}$														$F_{a2}^{1)}$			
		0	45	90	135	180	225	270	315	0	45	90	135	180	225	270	315		
<b>280 000</b>	4 500	10600	14000	14000	14000	14000	12500	9000	8500	14000	10600	10000	11200	14000	14000	14000	14000	9000	4500
	3 150	12500	14000	14000	14000	14000	14000	11200	10600	14000	12500	11800	13200	14000	14000	14000	14000	9000	4500
<b>355 000</b>	4 500	9500	14000	14000	14000	14000	11800	8000	7500	13200	9500	8500	10000	14000	14000	14000	14000	8500	4500
	3 150	11200	14000	14000	14000	14000	13200	10000	9500	14000	11200	10600	11800	14000	14000	14000	14000	9000	4500
<b>450 000</b>	4 500	8000	13200	14000	14000	14000	10600	7100	6300	11800	8500	7500	9000	13200	14000	14000	14000	8000	3750
	3 150	10600	14000	14000	14000	14000	11800	9500	8500	13200	10600	9500	10600	14000	14000	14000	14000	8500	4500
<b>560 000</b>	4 500	7100	12500	14000	14000	14000	9000	6000	5300	11200	7500	6700	8000	11800	14000	14000	14000	7500	3150
	3 150	9500	13200	14000	14000	14000	11200	8500	7500	11800	9500	8500	9500	12500	14000	14000	14000	7500	4500
<b>710 000</b>	4 500	6000	11200	14000	14000	14000	8000	5000	4500	10000	6700	5600	7100	10000	14000	14000	14000	6700	2500
	3 150	8500	11800	14000	14000	14000	10000	7500	6700	11200	8500	7500	9000	11800	14000	14000	14000	7100	4250
<b>900 000</b>	2 240	9500	12500	14000	14000	14000	11200	9000	8500	11800	9500	9000	10000	11800	14000	14000	14000	7500	4500
	4 500	5000	10000	14000	14000	14000	7100	4250	3750	9000	5600	5000	6300	9000	12500	14000	14000	6300	2000
<b>1 120 000</b>	3 150	7500	11200	14000	14000	13200	9000	6700	6000	10000	7500	7100	8000	10600	14000	14000	14000	6700	3750
	2 240	9000	11800	14000	14000	13200	10000	8000	7500	10600	9000	8000	9000	11200	14000	14000	13200	6700	4500
<b>1 400 000</b>	3 150	5600	9500	13200	14000	11800	7500	5000	4500	8500	6000	5300	6300	9000	11800	13200	12500	5600	2650
	2 240	7100	10000	13200	14000	11800	8500	6000	6000	9000	7100	6700	7500	9500	11800	13200	11800	6000	3750
<b>1 800 000</b>	3 150	5000	8500	12500	14000	11200	6700	4250	4000	8000	5300	4750	5600	8500	10600	12500	11800	5300	2240
	2 240	6700	9000	12500	13200	11200	7500	5600	5600	8500	6700	6000	6700	9000	11800	12500	11200	5300	3350
<b>2 240 000</b>	2 240	6000	8500	11800	12500	10000	7100	5300	5000	8000	6000	5600	6300	8500	10600	11800	10600	5000	3000
	1 600	6700	9000	10600	11200	10000	7500	6300	6000	8000	6700	6300	7100	8500	10000	11200	10000	5300	3750
<b>2 800 000</b>	2 240	5300	8000	11200	11800	9500	6300	4500	4250	7100	5300	5000	5600	7500	10000	11200	10000	4750	2500
	1 600	6300	8000	10000	10600	9500	7100	5600	5300	7500	6300	6000	6300	8000	9500	10600	9500	4750	3350
<b>3 550 000</b>	2 240	4750	7100	10000	11200	9000	5600	4000	3750	6700	4750	4250	5000	7100	9000	10000	9000	4250	2240
	1 600	5600	7500	9500	10000	8500	6700	5000	5000	7100	5600	5300	6000	7500	9000	10000	9000	4500	3000
<b>4 500 000</b>	2 240	4000	6700	9500	10600	8500	5300	3550	3150	6000	4250	3750	4500	6700	8500	9500	8500	4000	1900
	1 600	5300	7100	9000	9500	8000	6000	4750	4500	6700	5300	4750	5300	6700	8500	9500	8500	4250	2650
<b>5 600 000</b>	2 240	3550	6000	8500	9500	8000	4750	3000	2800	5600	3750	3350	4000	6000	7500	8500	8000	3750	1600
	1 600	4750	6700	8500	9000	7500	5600	4250	4000	6000	4750	4250	5000	6300	8000	9000	8000	3750	2360
<b>max 14 000</b>																	<b>max 9 000</b>	<b>max 4 500</b>	

Werte gültig für langsamlaufende Vollwelle<sup>3)</sup> (s. Kap. 22).

Values valid for solid low speed shaft<sup>3)</sup> (see ch. 22).

Größe size **360**

$n_2 \cdot L_h$ min <sup>-1</sup> · h	$M_2$ daN m	$F_{r2}$																$F_{a2}$	
		0	45	90	135	180	225	270	315	0	45	90	135	180	225	270	315		
<b>280 000</b>	6 300	15000	18000	18000	18000	18000	18000	13200	12500	18000	15000	14000	16000	18000	18000	18000	18000	11200	5600
	4 500	17000	18000	18000	18000	18000	18000	16000	15000	18000	17000	16000	18000	18000	18000	18000	18000	11200	5600
<b>355 000</b>	6 300	13200	18000	18000	18000	18000	16000	11800	10600	18000	14000	12500	14000	18000	18000	18000	18000	11200	5600
	4 500	16000	18000	18000	18000	18000	18000	14000	13200	18000	16000	15000	16000	18000	18000	18000	18000	11200	5600
<b>450 000</b>	6 300	11800	18000	18000	18000	18000	15000	10600	9500	17000	12500	11200	12500	18000	18000	18000	18000	11200	5600
	4 500	14000	18000	18000	18000	18000	17000	13200	12500	18000	14000	13200	15000	18000	18000	18000	18000	11200	5600
<b>560 000</b>	6 300	10600	17000	18000	18000	18000	13200	9000	8000	15000	11200	10000	11200	16000	18000	18000	18000	10600	5000
	4 500	13200	18000	18000	18000	18000	15000	11800	11200	17000	13200	11800	13200	17000	18000	18000	18000	10600	5600
<b>710 000</b>	6 300	9000	15000	18000	18000	18000	11800	7500	7100	14000	10000	8500	10000	15000	18000	18000	18000	9500	4250
	4 500	11800	16000	18000	18000	18000	14000	10600	9500	15000	11800	10600	12500	16000	18000	18000	18000	10000	5600
<b>900 000</b>	3 150	13200	17000	18000	18000	18000	15000	12500	11800	16000	13200	12500	13200	16000	18000	18000	18000	10600	5600
	6 300	7500	14000	18000	18000	18000	10600	6700	6000	13200	8500	7500	9000	13200	17000	18000	18000	9000	3550
<b>1 120 000</b>	4 500	10600	15000	18000	18000	18000	12500	9500	8500	14000	10600	10600	11200	15000	18000	18000	18000	9500	5600
	3 150	12500	15000	18000	18000	18000	14000	11200	10600	15000	12500	11800	12500	15000	18000	18000	18000	9500	5600
<b>1 400 000</b>	4 500	9500	14000	18000	18000	17000	11800	8500	7500	13200	10000	9000	10000	13200	18000	18000	18000	8500	4750
	3 150	11200	14000	18000	18000	17000	13200	10000	9500	14000	11200	10600	11800	14000	17000	18000	17000	9000	5600
<b>1 800 000</b>	4 500	8000	12500	18000	18000	16000	10600	7100	6700	11800	8500	7500	9000	12500	16000	18000	17000	8000	4000
	3 150	10000	13200	17000	18000	16000	11800	9000	8500	12500	10000	9500	10600	13200	16000	17000	16000	8000	5600
<b>2 240 000</b>	4 500	7100	11800	17000	18000	15000	9500	6300	5600	11200	8000	6700	8000	11800	15000	17000	16000	7500	3550
	3 150	9000	12500	16000	17000	15000	10600	8500	7500	11800	9500	8500	9500	11800	15000	16000	15000	7500	5000
<b>2 800 000</b>	3 150	8500	11800	15000	16000	14000	10000	7500	7100	10600	8500	8000	8500	11200	14000	16000	14000	7100	4500
	2 240	9500	11800	14000	15000	13200	10600	8500	8500	11200	9500	9000	9500	11800	14000	15000	13200	7500	5600
<b>2 800 000</b>	3 150	7500	10600	14000	16000	13200	9000	6700	6300	10000	7500	7100	8000	10600	13200	15000	13200	6700	4000
	2 240	8500	11200	13200	14000	12500	10000	8000	7500	10600	8500	8000	9000	10600	13200	14000	12500	6700	5000
<b>3 550 000</b>	3 150	6700	10000	14000	15000	12500	8000	6000	5300	9000	6700	6300	7100	9500	12500	14000	12500	6000	3350
	2 240	8000	10000	12500	13200	11800	9000	7100	6700	9500	8000	7500	8000	10000	11800	13200	11800	6300	4500
<b>4 500 000</b>	3 150	6000	9000	13200	14000	11200	7500	5300	4750	8500	6300	5600	6300	9000	11800	13200	11800	5600	3000
	2 240	7100	9500	11800	13200	11200	8500	6300	6000	9000	7100	6700	7500	9000	11200	12500	11200	6000	4000
<b>5 600 000</b>	3 150	5300	8500	11800	13200	10600	6700	4500	4000	7500	5600	5000	5600	8000	10600	11800	11200	5300	2500
	2 240	6300	9000	11200	12500	10600	7500	6000	5600	8500	6700	6000	6700	8500	10600	118			

## 20 - Bau- und Betriebsdetails

### Wirkungsgrad $\eta$ :

– Getriebe mit 1 Zahnradpaar (I) 0,98; mit 2 Zahnradpaaren (2I, CI) 0,96; mit 2 Zahnradpaaren und Zwischenrad (2I langes Modell) 0,95; mit 3 Zahnradpaaren (3I, ICI, C2I) 0,94; mit 3 Zahnradpaaren und Zwischenrad (3I langes Modell) 0,935; mit 4 Zahnradpaaren (4I, C3I) 0,92.

### Überbelastungen

Wenn das Getriebe hohen statischen und dynamischen Überbelastungen unterliegt, nachprüfen, dass der Wert der Überbelastungen  $2 \cdot M_{N2}$  (s. Kap. 7, 9; Kap. 11, 12, 14, 15 wobei  $M_{N2} = M_2 \cdot fs$ ) nicht überschreitet.

Überbelastungen entstehen normalerweise:

- Durch Anläufe bei voller Belastung (besonders für hohe Trägheiten und niedrige Übersetzungen); Abbremsungen; Stöße;
- bei Getrieben, in denen die langsamlaufende Welle durch die Trägheit der angetriebenen Maschine als Antrieb wirkt;
- durch angelegte Leistung höher als die erforderliche; andere statische oder dynamische Ursachen.

Es folgen anschließend einige Aufschlüsse über diese Überbelastungen samt Berechnungsformeln für einige typische Anwendungsfälle. Sollte es nicht möglich sein, den Betrag der Überbelastungen genau zu bestimmen, Sicherheitsvorrichtungen einbauen, damit niemals  $2 \cdot M_{N2}$  überschritten wird.

### Anlaufdrehmoment

Bei Anlauf mit voller Belastung nachprüfen, (besonders für hohe Trägheiten und niedrige Übersetzungen), dass  $2 \cdot M_{N2}$  größer als oder gleich Anlaufdrehmoment ist. Hierbei gilt die Formel:

$$M_2 \text{ Anlauf} = \left( \frac{M \text{ Anlauf}}{M_N} \cdot M_2 \text{ verfügbar} - M_2 \text{ erfordert} \right) \frac{J}{J + J_0} + M_2 \text{ erfordert}$$

wobei:  
 $M_2$  erfordert, das von der Maschine durch Arbeit und Reibung aufgenommene Drehmoment ist;  
 $M_2$  verfügbar, das von der Motornennleistung bedingte Abtriebsdrehmoment darstellt;  
 $J_0$  das Motormassenträgheitsmoment ist;  
 $J$  das auf die Motorachse bezogene Außenmassenträgheitsmoment in  $\text{kg m}^2$  ist (Getriebe, Kupplungen, angetriebene Maschine);  
 für die anderen Zeichen s. Kap. 2b.

ANMERKUNG: Bei der Nachprüfung, dass das Anlaufdrehmoment genügend hoch für den Anlauf ist, sind bei der Auswertung von  $M_2$  erfordert etwaige Anlaufreibungen zu berücksichtigen.

### Anhalten von Maschinen mit hoher kinetischer Energie (hohe Trägheitsmomente bei hohen Drehzahlen) mit Bremsmotor

Bremsbeanspruchung anhand nachstehender Formel nachprüfen:

$$\left( \frac{Mf}{\eta} \cdot i + M_2 \text{ erfordert} \right) \frac{J}{J + J_0} - M_2 \text{ erfordert} \leq 2 \cdot M_{N2}$$

wobei:  
 $Mf$  das Eichbremsmoment darstellt (s. Tabelle Kap. 2b);  
 andere Zeichen s. oben und Kap. 1.

### Betrieb mit Bremsmotor

#### Anlaufzeit $t_a$ und Motordrehwinkel $\varphi_{a1}$

$$t_a = \frac{(J_0 + J) \cdot n_1}{95,5 \left( M \text{ Anlauf} - \frac{M_2 \text{ erfordert}}{i} \right)} \text{ [s];} \quad \varphi_{a1} = \frac{t_a \cdot n_1}{19,1} \text{ [rad]}$$

#### Bremszeit $t_f$ und Motordrehwinkel $\varphi_{f1}$

$$t_f = \frac{(J_0 + J) \cdot n_1}{95,5 \left( Mf + \frac{M_2 \text{ erfordert}}{i} \right)} \text{ [s];} \quad \varphi_{f1} = \frac{t_f \cdot n_1}{19,1} \text{ [rad]}$$

$M$  Anlauf [daN m] das Anlaufdrehmoment des Motors  $\left( \frac{955 \cdot P_1}{n_1} \cdot \frac{M \text{ Anlauf}}{M_N} \right)$  ist (s. Kap. 2b);  
 $Mf$  [daN m] das Eichbremsmoment des Motors darstellt (s. Kap. 2b);  
 andere Zeichen s. oben und Kap. 1.

Die Wiederholung des Bremsvorgangs entsprechend der Temperaturänderung der Bremse sowie dem Abnutzungszustand des Bremsbelages ist – in den normalen Grenzen des Luftspaltes und der Raumfeuchtigkeit sowie mit entsprechenden Elektrogeräten – ungefähr  $\pm 0,1 \cdot \varphi_{f1}$ .

### Dauer des Bremsbelages

Die Anzahl der Bremsungen zwischen zwei Einstellungen (s. gesonderte Unterlagen) ergibt sich in etwa aus der Formel:

$$\frac{W \cdot 10^5}{Mf \cdot \varphi_{f1}}$$

wobei:  
 $W$  [MJ] die Reibungsarbeit zwischen zwei Luftspalteinstellungen lt. Tabelle darstellt; andere Zeichen s. oben.

Der Luftspaltwert schwankt zwischen 0,25 und 0,6; im allgemeinen sind 5 Einstellungen möglich.

## 20 - Structural and operational details

### Efficiency $\eta$ :

– gear reducer with 1 gear pair (I) 0,98; with 2 gear pairs (2I, CI) 0,96; with 2 gear pairs and 1 idle gear (2I long model) 0,95; with 3 gear pairs (3I, ICI, C2I) 0,94; with 3 gear pairs and 1 idle gear (3I long model) 0,935; with 4 gear pairs (4I, C3I) 0,92.

### Overloads

When a gear reducer is subjected to high static and dynamic overloads, the need arises for verifying that such overloads will always remain lower than  $2 \cdot M_{N2}$  (see ch. 7, 9; see ch. 11, 12, 14, 15 where  $M_{N2} = M_2 \cdot fs$ ).

Overloads are normally generated when one has:

- starting on full load (especially for high inertias and low transmission ratios), braking, shocks;
- gear reducers in which the low speed shaft becomes driving member due to driven machine inertia;
- applied power higher than that required; other static or dynamic causes.

The following general observations on overloads are accompanied by some formulae for carrying out evaluations in certain typical instances.

When no evaluation is possible, install safety devices which will keep values within  $2 \cdot M_{N2}$ .

### Starting torque

When starting on full load (especially for high inertias and low transmission ratios), verify that  $2 \cdot M_{N2}$  is equal to or greater than starting torque, by using the following formula:

$$M_2 \text{ start} = \left( \frac{M \text{ start}}{M_N} \cdot M_2 \text{ available} - M_2 \text{ required} \right) \frac{J}{J + J_0} + M_2 \text{ required}$$

where:  
 $M_2$  required is torque absorbed by the machine through work and frictions;  
 $M_2$  available is output torque due to the motor's nominal power;  
 $J_0$  is the moment of inertia (of mass) of the motor;  
 $J$  is the external moment of inertia (of mass) in  $\text{kg m}^2$  (gear reducers, couplings, driven machine) referred to the motor shaft;  
 for other symbols see ch. 2b.

NOTE: when seeking to verify that starting torque is sufficiently high for starting, take into account starting friction, if any, in evaluating  $M_2$  required.

### Stopping machines with high kinetic energy (high moments of inertia combined with high speeds) with brake motor

Verify braking stress by means of the formula:

$$\left( \frac{Mf}{\eta} \cdot i + M_2 \text{ required} \right) \frac{J}{J + J_0} - M_2 \text{ required} \leq 2 \cdot M_{N2}$$

where:  
 $Mf$  is the braking torque setting (see table in ch. 2b); for other symbols see above and ch. 1.

### Operation with brake motor

#### Starting time $t_a$ and revolutions of motor $\varphi_{a1}$

$$t_a = \frac{(J_0 + J) \cdot n_1}{95,5 \left( M \text{ start} - \frac{M_2 \text{ required}}{i} \right)} \text{ [s];} \quad \varphi_{a1} = \frac{t_a \cdot n_1}{19,1} \text{ [rad]}$$

#### Braking time $t_f$ and revolutions of motor $\varphi_{f1}$

$$t_f = \frac{(J_0 + J) \cdot n_1}{95,5 \left( Mf + \frac{M_2 \text{ required}}{i} \right)} \text{ [s];} \quad \varphi_{f1} = \frac{t_f \cdot n_1}{19,1} \text{ [rad]}$$

$M$  start [daN m] is motor starting torque  $\left( \frac{955 \cdot P_1}{n_1} \cdot \frac{M \text{ start}}{M_N} \right)$  (see ch. 2b);

$Mf$  [daN m] is the braking torque setting of the motor (see ch. 2b);  
 for other symbols see above and ch. 1.

Assuming a regular air-gap and ambient humidity, and utilizing suitable electrical equipment, repetition of the braking action, as affected by variation in temperature of the brake and by the state of wear of friction surface, is approx  $\pm 0,1 \cdot \varphi_{f1}$ .

### Duration of friction surface

As a rough guide (see specific literature), the number of breakings permissible between successive adjustments of the air-gap is given by the formula:

$$\frac{W \cdot 10^5}{Mf \cdot \varphi_{f1}}$$

wobei:  
 $W$  [MJ] is the work of friction between successive adjustments of the air-gap as indicated in the table; for other symbols see above.

The air-gap should measure between 0,25 minimum and 0,6 maximum; as a rough guide, 5 adjustments can be made.

Getriebe größe Motor size	W MJ
63	10,6
71	14
80	18
90	24
100	24
112	45
132	67
160, 180M	90
180L, 200	125

**Winkelspiel und Verdrehsteifigkeit der langsamlaufenden Welle**

**Richtwerte** des Winkelspiels bei festgesperrter schnelllaufender Welle sind in der Tabelle angegeben. Das Winkelspiel ist von Temperatur und Übersetzung abhängig. In der Tabelle sind auch die **Richtwerte** der Verdrehfestigkeit der langsamlaufenden Welle bei festgesperrter schnelllaufender Welle in Abhängigkeit des Zahnradgetriebes angegeben. Richtwerte der Tab. gelten auch für das lange Modell. Auf Anfrage sind Getriebe mit **reduziertem Spiel** erforderlich, das  $\leq$  der Tabellenwert sein kann.

1) 1 m von der Mitte der langsamlaufenden Welle berechnet man das Winkelspiel in mm, indem die Tabellenwerte mit 1 000 multipliziert werden (1 rad = 3438').  
2) Werte gültig bei Nennlastbedingungen.

**Trägheitsmoment (Massen-)  $J_1$  [kg m<sup>2</sup>]**

Zahnradgetr. Train of gears	$i_N$	Getriebegröße - Gear reducer size										
		100	125	140	160	180	200	225	250	280	320, 321	360
I	2,5	0,0026	0,0085	-	0,0299	-	0,0848	-	0,2617	-	0,8918	-
	3,15	0,0020	0,0068	0,0110	0,0238	0,0399	0,0667	0,1160	0,2067	0,3411	0,6987	1,1885
	4	0,0015	0,0045	0,0085	0,0167	0,0309	0,0466	0,0872	0,1433	0,2599	0,4872	0,8992
	5	0,0011	0,0034	0,0057	0,0131	0,0213	0,0354	0,0613	0,1091	0,1823	0,3698	0,6344
2I	6,3 ... 12,5	0,0009	0,0029	0,0031	0,0091	0,0102	0,0292	0,0325	0,0893	0,0987	0,2812	0,3158
	6,3 ... 12,5 <sup>1)</sup>	0,0014	0,0043	0,0045	0,0133	0,0144	0,0430	0,0463	0,1279	0,1373	0,3967	0,4313
	14 ... 28	-	0,0014	0,0017	0,0046	0,0055	0,0151	0,0185	0,0518	0,0566	0,1448	0,1747
	14 ... 28 <sup>1)</sup>	-	0,0022	0,0025	0,0067	0,0086	0,0216	0,025	0,0709	0,0757	0,1981	0,2555
3I	28 ... 63	-	-	-	0,0019	0,0020	0,006	0,0063	0,0181	0,019	0,0599	0,0537
	28 ... 63 <sup>1)</sup>	-	-	-	0,0023	0,0024	0,0074	0,0077	0,022	0,0229	0,0715	0,0576
	71 ... 160	-	-	-	0,0009	0,0009	0,0027	0,0028	0,0083	0,0085	0,027	0,0248
	71 ... 160 <sup>1)</sup>	-	-	-	0,001	0,001	0,0031	0,0031	0,0093	0,0095	0,0303	0,0258
CI	5 ... 8	0,0013	0,0038	0,0042	0,0123	0,0137	0,0369	0,0414	0,1093	0,1281	0,3372	0,4004
	9 ... 11,2	0,0009	0,0025	0,0033	0,0072	0,0105	0,0223	0,0321	0,0706	0,1001	0,2214	0,3146
	12,5 ... 16	-	0,0015	0,0018	0,0051	0,0061	0,0158	0,0187	0,0502	0,0589	0,1496	0,1929
	18, 20	-	0,0008	0,0010	0,0029	0,0035	0,0085	0,0102	0,0279	0,0328	0,114	0,1319
C2I	20 ... 31,5	-	-	-	0,0039	0,0042	0,0125	0,0133	0,0375	0,0398	0,1131	0,1214
	35,5 ... 63	-	-	-	0,0017	0,0018	0,0055	0,0058	0,0172	0,0179	0,0548	0,0574
	71 ... 100	-	-	-	0,0007	0,0007	0,0025	0,0026	0,0074	0,0076	0,024	0,0248
	125, 160	-	-	-	0,0004	0,0004	0,0013	0,0013	0,0038	0,0039	0,0133	0,0136
ICI	31,5 ... 80	-	-	-	0,001	0,0011	0,0032	-	-	-	-	-
	100 ... 200	-	-	-	0,0005	0,0005	0,0015	-	-	-	-	-

1) Werte gültig für langes Modell.

1) Values valid for long model.

**Getriebeantriebsseite**

Die Größen 50 ... 100 der Getriebe **R 2I, R CI** und die Größen 125 ... 360 der Getriebe **R I, R 2I, R 3I** weisen auf der Getriebeantriebsseite (auch auf der Gegenseite bei **R I**) eine bearbeitete Fläche und Gewindebohrungen zur eventuellen Befestigung einer Motorlaterne od. and. auf. Bei den Größen 125 ... 360 der Getriebe **R CI, R C2I** s. Kap. 10.

**Gear reducers input face**

The input face of gear reducers **R 2I, R CI** (sizes 50 ... 100) and **R I, R 2I, R 3I** (sizes 125 ... 360) has a machined surface with tapped holes for fitting motor mounting etc. (also opposite side to input face for **R I**). For **R CI, R C2I** gear reducers (sizes 125 ... 360) see ch. 10.

**R 2I, R CI (Größen 50 ... 100)**  
**R 2I, R CI (sizes 50 ... 100)**

Getriebegröße Gear reducer size	a	A	B	F	K Ø H8	T Ø	U
50	16	72	54	M 5	5	103	66
63, 64	20	81,5	66,5	M 5	5	119	80
80, 81	25	106	80	M 6	6	149	96
100	31,3	125	108	M 8	8	187	129

1) Nutzlänge des Gewindes 2 · F. 1) Working length of thread 2 · F.  
2) Nutzlänge der Bohrung 1,6 · K. 2) Working depth of hole 1,6 · K.  
Für den Wert des Maßes  $V_0$  (nur R CI) s. For dimension  $V_0$  (R CI only) see ch. 10.  
Kap. 10.

**R I, R 2I, R 3I (Größen 125 ... 360)**  
**R I, R 2I, R 3I (sizes 125 ... 360)**

Getriebegröße Gear reducer size	A <sub>1</sub>	A <sub>2</sub>	A <sub>3</sub>	B	F	T Ø
125, 140	140	138	81	113	162	M 12 25
160, 180	160, 180	165 96	135	201	M 16 32	
200, 225	200, 225	207 115	162	250	M 20 40	
250, 280	250, 280	258 143	203	310	M 24 48	
320 ... 360	320 ... 360	327 180	252	386	M 30 60	

1) Nutzlänge des Gewindes 2 · F. 1) Working length of thread 2 · F.  
Bei Bedarf bei der Zentrierung, bitte rückfragen. If spigot is required consult us.

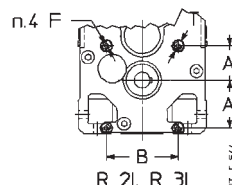
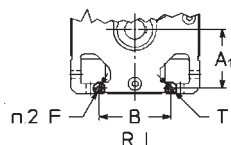
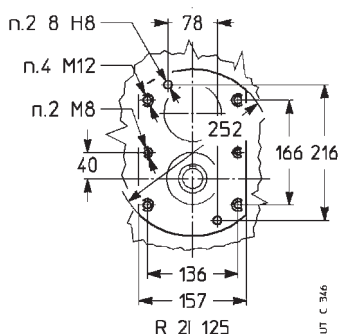
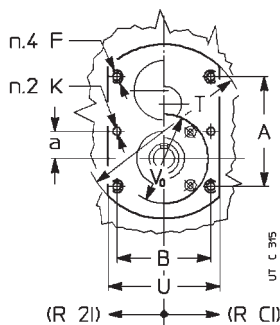

## 20 - Bau- und Betriebsdetails

Die Antriebsseite der **R 3I** (Größen 63 ... 125) und **R ICI** Getriebe weist einen bearbeiteten Flansch und Bohrungen zur eventuellen Befestigung einer Motorlaterne od. and. auf.

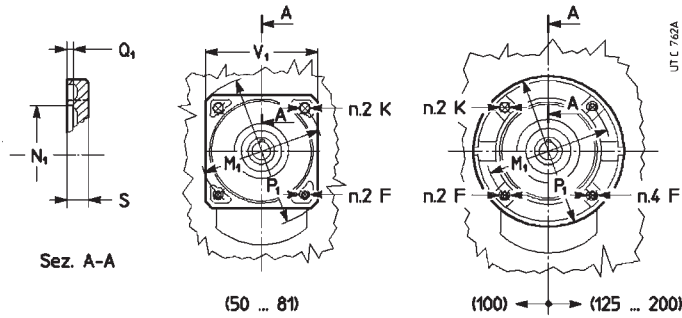

## 20 - Structural and operational details

The input face of gear reducers **R 3I** (sizes 63 ... 125) and **R ICI** has a machined flange with holes for fitting motor mounting etc.

### R 3I, R ICI

Getriebegröße Gear reducer size		F	K	M <sub>1</sub>	N <sub>1</sub>	P <sub>1</sub>	V <sub>1</sub>	Q <sub>1</sub>	S
<b>R 3I</b>	<b>R ICI</b>	1)			H7				
<b>63, 64</b>	<b>50</b>	M 8	9,5	115	95	140	105	4	11
<b>80, 81</b>	<b>63 ... 81</b>	M 8	9,5	130	110	160	120	4,5	12
<b>100</b>	<b>100</b>	M 10	11,5	165	130	200	—	4,5	14
<b>125</b>	<b>125, 140</b>	M 10	—	165	130	200	—	4,5	16
—	<b>160, 180</b>	M 12	—	215	180	250	—	5	18
—	<b>200</b>	M 12	—	265	230	300	—	5	20

1) Nutzlänge des Gewindes 1,25 · F.

1) Working length of thread 1,25 · F.

### Wellenende

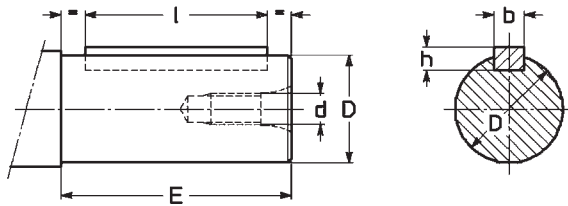

Wellenende - Shaft end

### Shaft end

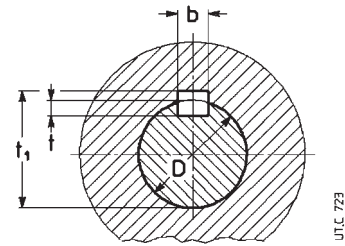

Langsamlaufende Hohlwelle - Hollow low speed shaft

Wellenende Shaft end			Passfeder Parallel key		Nutm Keyway				
D <sup>1)</sup> Ø	E <sup>2)</sup>	d Ø	b × h × l <sup>2)</sup>	b	t	t <sub>1</sub>			
11	j6	23	M 5	4 × 4 × 18	4	2,5	12,7		
14	j6	30	M 6	5 × 5 × 25	5	3	16,2		
16	j6	30	M 6	5 × 5 × 25	5	3	18,2		
19	j6	40	(30)	M 6	6 × 6 × 36	(25)	6	3,5	21,7
24	j6	50	(36)	M 8	8 × 7 × 45	(25)	8	4	27,2
28	j6	60	M 8	8 × 7 × 45	8	4	31,2		
30	j6	58	M 10	8 × 7 × 45	8	4	33,2		
32	k6	80	(58)	M 10	10 × 8 × 70	(50)	10	5	35,3
38	k6	80	(58)	M 10	10 × 8 × 70	(50)	10	5	41,3
40	k7	58	M 10	12 × 8 × 50	12	5	43,3		
42	k6	110	M 12	12 × 8 × 90	12	5	45,3		
48	k6	110	(82)	M 12	14 × 9 × 90	(70)	14	5,5	51,8
55	m6	110	M 12	16 × 10 × 90	16	6	59,3		
60	m6	140	(105)	M 16	18 × 11 × 110	(90)	18	7	64,4
65	m6	140	M 16	18 × 11 × 110	18	7	69,4		
70	m6	140	(105)	M 16	20 × 12 × 125	(90)	20	7,5	74,9
75	m6	140	M 16	20 × 12 × 125	20	7,5	79,9		
80	m6	170	(130)	M 20	22 × 14 × 140	(110)	22	9	85,4
90	m6	170	(130)	M 20	25 × 14 × 140	(110)	25	9	95,4
95	m6	170	M 20	25 × 14 × 140	25	9	100,4		
100	m6	210	(165)	M 24	28 × 16 × 180	(140)	28	10	106,4
110	m6	210	(165)	M 24	28 × 16 × 180	(140)	28	10	116,4
125	j6	200	M 30	32 × 18 × 180	32	11	132,4		
140	j6	200	M 30	36 × 20 × 180	36	12	148,4		
160	j6	240	M 36	40 × 22 × 220	40	13	169,4		
180	j6	240	M 36	45 × 25 × 220	45	15	190,4		

1) Die Toleranz gilt nur für schnelllaufendes Wellenende. Bei langsamlaufendem Wellenende (Kap. 22) hat Durchmesser D die Toleranz **h7** für D ≤ 60, **j6** für D = 70 ... 180.

2) Die in Klammern stehenden Werte beziehen sich auf das kurze Wellenende.

1) Tolerance valid only for high speed shaft end. Diameter D tolerance for low speed shaft end (ch. 22) is **h7** for D ≤ 60, **j6** for D = 70 ... 180.

2) Values in brackets are for short shaft end.

Bohrung Hole	Passfeder Parallel key	Nutm Keyway		
D Ø H7	b × h × l*	b	t	t <sub>1</sub>
19	6 × 6 × 50	6	3,5	21,7
24	8 × 7 × 63	8	4	27,3
30	8 × 7 × 63	8	4,5 <sup>1)</sup>	32,7 <sup>1)</sup>
32	10 × 8 × 70	10	5	35,3
38	10 × 8 × 90	10	5,5 <sup>1)</sup>	40,7 <sup>1)</sup>
40	12 × 8 × 90	12	5	43,3
48	14 × 9 × 110	14	5,5	51,8
60	18 × 11 × 140	18	7	64,4
70	20 × 12 × 180	20	8 <sup>1)</sup>	74,3 <sup>1)</sup>
80	22 × 14 × 200	22	9	85,4
90	25 × 14 × 200	25	9	95,4
100	28 × 16 × 250	28	10	106,4
110	28 × 16 × 250	28	10	116,4
125	32 × 18 × 320	32	11	132,4
140	36 × 20 × 320	36	12	148,4
160	40 × 22 × 400	40	14 <sup>1)</sup>	168,3 <sup>1)</sup>
180	45 × 25 × 400	45	15	190,4

\* Empfohlene Länge.  
1) **Nicht** genormte Werte.

\* Recommended length.  
1) Values **not** to standard.

**Maschinenzapfen**

Der Maschinenzapfen, auf den die Getriebehohlwelle aufgezogen wird, soll nach den in Tabelle angegebenen Abmessungen und nach den Abbildungen unten sein.

Größen 40, 63: Verkeilung mit Passfeder (Abb. a) oder Verkeilung mit Passfeder und Spannringen (Abb. b).

Größen 64 ... 360: Verkeilung mit Passfeder (Abb. c) oder Verkeilung mit Passfeder und Spannbuchse (Abb. d); s. auch Kap. 21 und 22.

Bei zylindrischem Maschinenzapfen mit einzigem Durchmesser D (Abb. a, c) empfehlen wir für Sitz D auf Einziehseite die Toleranz h6, j6 (Gr. ≤ 225) oder g6, h6 (Gr. ≥ 250), um die Montage zu erleichtern.

**Wichtig:** Der Durchmesser des gegen das Getriebe anschlagenden Maschinenzapfens muss mindestens  $(1,18 \div 1,25) \cdot D$  betragen.

**Shaft end of driven machine**

Dimensions of shaft end to which the gear reducer's hollow shaft is to be keyed are those recommended in the table and shown in the figures below.

Sizes 40, 63: fitting with key (fig. a) or fitting with key and locking rings (fig. b).

Sizes 64 ... 360: fitting with key (fig. c) or fitting with key and locking bush (fig. d); see also ch. 21 and 22.

In the case of cylindrical shaft end with only diameter D (fig. a, c), for the seat D on input side, we recommend tolerance h6, j6 (sizes ≤ 225) or g6, h6 (sizes ≥ 250), to facilitate mounting.

**Important:** the shoulder diameter of the shaft end of the driven machine abutting with the gear reducer must be at least  $(1,18 \div 1,25) \cdot D$ .

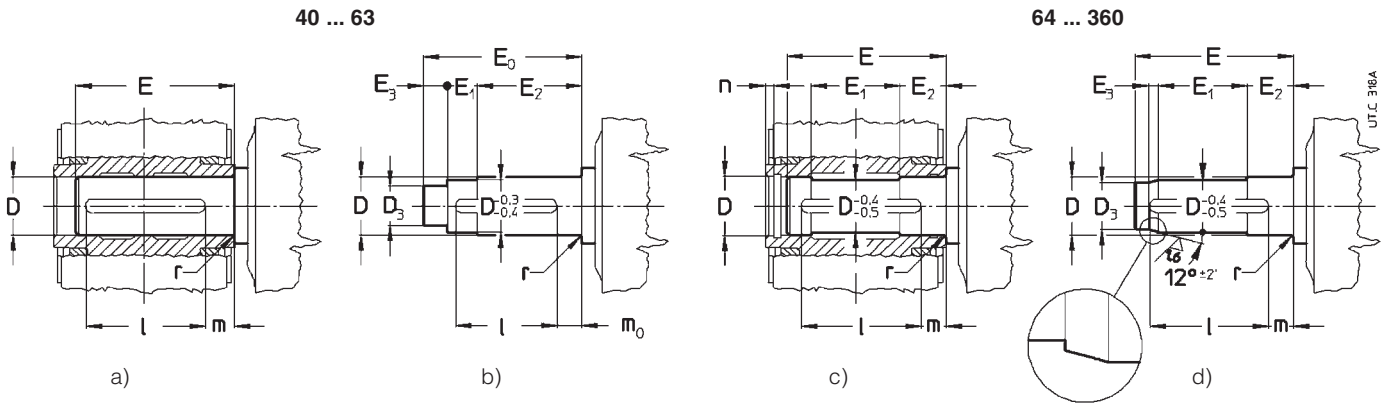

Getriebe- größe Gear reducer size	D Ø	D <sub>3</sub> Ø H7/h6	E	E <sub>0</sub>	E <sub>1</sub>	E <sub>2</sub>	E <sub>3</sub>	l	m	m <sub>0</sub>	n	r
<b>40</b>	19	15	76,5	81	14	53	14	50	21	14	—	1,5
<b>50</b>	24	19	90,5	95	21	60	14	63	21,5	15	—	1,5
<b>63</b>	30 <sup>1)</sup>	25	107,5	112,5	19,5	72	21	63	31,5	25	—	1,5
<b>64</b>	32	27	110	—	57	34	10	70	28	—	6	1,5
<b>80</b>	38 <sup>1)</sup>	32	134	—	71	39,5	12	90	30	—	6	1,5
<b>81</b>	40	34	134	—	71	39,5	12	90	30	—	6	1,5
<b>100</b>	48	41	162	—	87	46,5	14	110	35	—	7	2
<b>125</b>	60	52	201	—	110	55	16	140	40	—	7	2
<b>140</b>	70 <sup>1)</sup>	62	228	—	124	63	16	180	35	—	8	2
<b>160</b>	80	70	250	—	136	68	21	200	36	—	8	3
<b>180</b>	90	80	274	—	150	75	21	200	50	—	9	3
<b>200</b>	100	88	308	—	174	80	25	250	42	—	10	3
<b>225</b>	110	98	331	—	180	90	25	250	55	—	10	3,5
<b>250</b>	125	110	380	—	212	100	32	320	40	—	11	4
<b>280</b>	140	125	410	—	220	112	32	320	60	—	12	4
<b>320, 321</b>	160 <sup>1)</sup>	140	471	—	258	125	43	400	45	—	13	5
<b>360</b>	180	160	506	—	272	137	43	400	72	—	14	5

1) Nicht genormte Passfedernutttiefe (s. Tabelle «Langsamlaufende Hohlwelle-», Maß t).

1) Keyway depth not to standard (see «Hollow low speed shaft» table, dimension t).

**Bezugsrille**

Der Bezug, um die langsamlaufende Hohlwellenseite festzustellen, wo die Radialbelastung angreift, wird durch eine Rille entsprechend der Abbildung daneben dargestellt.

Das Symbol ● auf dem Schema «Bauart» in Kap. 8, 10, 13, 16 verdeutlicht die Position der Bezugsrille.

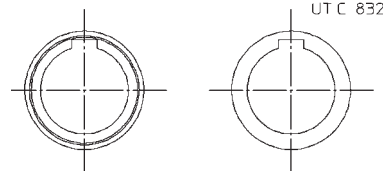

Seite Bezugsrille ● Gegenseite Bezugsrille  
groove side ● opposite side to groove

**Reference groove**

The reference for identification of the side of the hollow low speed shaft to which a radial load is applied, is provided by a groove as shown in the drawing alongside.

The position of the reference groove is shown by the symbol ● in the drawings «Design» of ch. 8, 10, 13 and 16.

Schraubenposition und Gewindebohrungsabmessungen

Plug position and threaded hole dimensions

Ansichtsfläche / view side    entgegengesetzte Seite / opposite side

nur Größe 80, 81  
only size 80, 81

Nur Größe 140, 180  
Only size 140, 180

auch entgegengesetzte Seite  
also opposite side

nur Größe 80, 81  
only size 80, 81

UTC 763C

nur 100 UP4...  
only 100 UP4...

I (63, 80)  
CI, ICI, C3I (40 ... 81)

I, CI (100)  
ICI (100 ... 200)  
C3I (100, 125)

2I, 3I (40 ... 81)  
4I (63 ... 81)

2I, 3I, 4I (100, 125)

Größe Size	Gewindebohrungen Threaded holes	
	Getriebe Gear reducer	Extruderlager Extruder support
40 ... 50	G 1/4"	-
63 ... 81	M 16 x 1,5	
100	G 1/2"	M 16 x 1,5
125		
140	G 3/4"	G 1/2"
160 ... 225		
250 ... 280	G 1"	G 3/4"
320 ... 360		

auch entgegengesetzte Seite  
also opposite side

auch entgegengesetzte Seite  
also opposite side

auch entgegengesetzte Seite  
also opposite side

I, CI (125 ... 225)

I, CI (250 ... 360)

2I, 3I, C2I (140 ... 360)

Einfüll- und Ölstandschraben

Filler and level plugs

2I, 3I, 4I (100, 125)  
Bauform V6  
mounting position V6

3I (125)  
Bauform V5<sup>1)</sup>  
mounting position V5<sup>1)</sup>

ICI (100 ... 200)  
Bauform B6<sup>1)</sup>  
mounting position B6<sup>1)</sup>

C3I (50 ... 125)  
Bauform B6<sup>1)</sup>  
mounting position B6<sup>1)</sup>

Überlaufölstandschrabe  
Plug for flowing over level

Einfüllschraube  
Filler plug

Ölstandschrabe  
Level plug

Einfüllschraube  
Filler plug

UTC 484

UTC 774

UTC 370

1) Bei Dauerbetrieb mit hoher Drehzahl ist ein Ausgleichbehälter vorgesehen: rückfragen.

1) For high input speed continuous duty an expansion tank is envisaged: consult us.

Abmessungen der Befestigungsschrauben der GetriebefüÙe

Fixing bolt dimensions for gear reducer feet

Sitzmutter  
nut seating

Sitz der Schraube oder Mutter  
bolt or nut seating

Sitz der Schraube oder Mutter  
bolt or nut seating

Getriebe- größe Gear reducer size	Schraube Bolt UNI 5737-88 (l max)
40	M 6 x 22
50	M 8 x 30
63, 64	M 10 x 35
80, 81	M 12 x 40
100	M 14 x 50
125, 140	M 16 x 55
160, 180	M 20 x 70
200, 225	M 24 x 9
250, 280	M 30 x 110
320 ... 360	M 36 x 130

KappenaußenmaÙe (Größen 63. 64. 125 und 140)

Cap overall dimension (sizes 63, 64, 125 and 140)

Bei den in der Tabelle angegebenen Getrieben und Getriebemotoren hat die der schnellaufenden Wellenseite gegenüberliegende Kappe infolge der Vorbereitung für die Rücklaufsperrung 4 mm Überstand zum Maß H<sub>1</sub>.

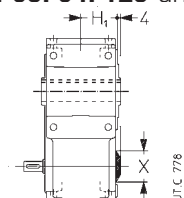

Getriebegröße Gear reducer size	X Ø
63, 64	47
125	72
140	72

In the gear reducers and gearmotors shown in the table the cap opposite to the high speed shaft projects 4 mm over the dimension H<sub>1</sub>, owing to the backstop prearrangement.



**Gewindebohrungen des Befestigungsflansches (Größen 125 ... 321)**

Die entsprechenden Durchgangsbohrungen müssen 8 auch für die Größe 125 und alle gleich für die Größen 140, 200 und 250 sein (Ø jeweils 15, 21 und 25).

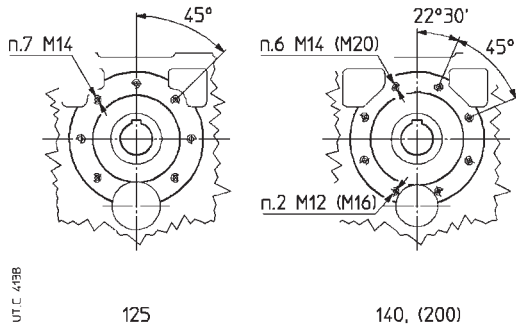

**Tapped holes on fixing flange (sizes 125 ... 321)**

The clearance holes must be 8 for size 125 as well and all of equal diameter for sizes 140, 200 and 250 (Ø 15, 21 and 25, respectively).

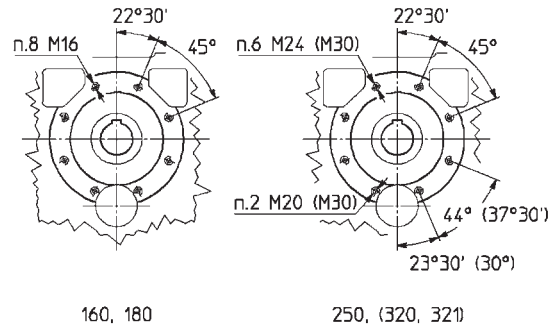

**Aussparung (2l, 3l, 4l Größen 40 ... 125)**

Die Größen 2l, 3l, 4l 40 ... 125 weisen ein Gehäuse mit Aussparung mit bearbeiteten Seitenflächen auf. Die Aussparung liegt auf der «schnelllaufenden» Seite (auf der Gegenseite der Rille). Sie dient zum Sitz der Feder und eines Endes der Drehmomentstütze zur Aufsteckbefestigung (s. Kap. 22 «Aufsteckbefestigungen»).

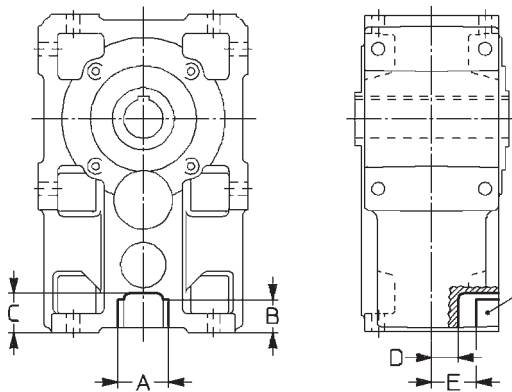

**Reaction recess (2l, 3l, 4l sizes 40 ... 125)**

Sizes 2l, 3l, 4l 40 ... 125 have a casing with a reaction recess having machined lateral surfaces, laying on the high speed side (opposite to groove), for the seating of springs and torque arm end for shaft mounting (see ch. 22, «Shaft mounting arrangements»).

Getriebegröße Gear reducer size	A	B	C	D	E
H11			≈		
40	23	18,5	22	14	25
50	29,7	23,5	26	15,5	28
63, 64	32,5	25,5	31	22,5	36,5
80, 81	45,8	27	36	27	41
100	63	27	38,5	36	54,5
125	67	37	52	46	64

**Zone der langsamlaufenden Welle (Größen 140, 180, 225, 280, 360)**

Bei den Stirnradgetrieben der normalen Serie kann die etwaige Scheibe (am Anschlag montiert, wie immer empfohlen) folgenden Durchmesser haben:

- **R 1**, bei einer Distanz von  $H_1 + Q + 3$  (Kap. 8), 115 (Gr. 140), 150 (Gr. 180), 180 (Gr. 225), 230 (Gr. 280), 300 (Gr. 360)
- **R 2l, R 3l**, bei einer Distanz von  $H_1 + Q + 3$  (Kap. 8), 315 (Gr. 140), 400 (Gr. 180), 500 (Gr. 225), 630 (Gr. 280), 800 (Gr. 360).

Die Anwendung von Scheiben größeren Durchmessers ist akzeptiert, nur wenn sie vom Wellenende nicht überhangen und wenn die max Radialbelastungen respektiert werden (s. Kap. 18); bei Bedarf, bitte rückfragen.

**Low speed shaft zone (sizes 140, 180, 225, 280, 360)**

In standard model parallel shaft gear reducers the perspective pulley, if mounted against shaft soulder (always advisable), can have a maximum diameter of:

- **R 1**, at the distance  $H_1 + Q + 3$  (ch. 8), 115 (size 140), 150 (size 180), 180 (size 225), 230 (size 280), 300 (size 360)
- **R 2l, R 3l**, at the distance  $H_1 + Q + 3$  (ch. 8), 315 (size 140), 400 (size 180), 500 (size 225), 630 (size 280), 800 (size 360).

The use of pulleys with larger diameter is allowed on condition that they don't overhang from the shaft end and provided that the maximum radial load values are observed (see ch.18); consult us if need be.



Stirnradgetriebe  
Parallel shaft gear reducers  
(l 140, 180, 225, 280, 360)

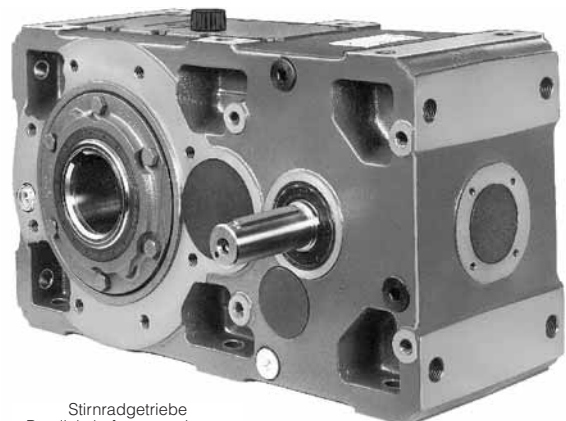

Stirnradgetriebe  
Parallel shaft gear reducers  
(2l, 3l 140, 180, 225, 280, 360)

## 21 - Aufstellung und Wartung

### Allgemeines

Achten, dass die Unterkonstruktion, auf welcher das Getriebe oder der Getriebemotor montiert und befestigt wird, eben, nivelliert und ausreichend dimensioniert ist, um Befestigungsfestigkeit und Vibrationsfreiheit zu gewährleisten, unter Betrachtung der übersetzten Kräfte der Massen, des Drehmoments, der Radial- und Axialbelastungen.

Getriebe oder Getriebemotoren benötigen ausreichende Luft für die Kühlung des Getriebes und des Motors (dies gilt besonders für die Lüfterseite sowohl des Motors als auch des Getriebes).

Wenn das Getriebe mit Lüfter ausgerüstet ist, muss genügend Platz fürs Absaugen der Kühlluft auch nach der Montage der Kupplung vorgesehen werden; wenn notwendig, die Kupplungsnabe abfasen.

Darauf achten, dass der Kühlluftdurchgang nicht verstopft ist, das Getriebe nicht in der Nähe von Heizquellen mit Einwirkung auf Kühl- und Getriebelufttemperatur (für Ausstrahlung) aufgestellt wird, genügend Luft zu- und abströmen kann, überhaupt Einsätze ohne geregelte Wärmeabgabe vermieden werden.

Getriebe vibrationsfrei aufstellen.

Bei Einwirkungen von Außenlasten sind bei Bedarf Stifte oder Sperrvorrichtungen vorzusehen.

Bei der Befestigung zwischen Getriebe und Maschine und/oder zwischen Getriebe und eventuellem **B5** Flansch ist es empfohlen, **Starkkleber** Typ **LOCTITE** in den Befestigungsschrauben anzuwenden (auch in den Passflächen zur Flanscbefestigung).

Bei Aufstellung im Freien oder in stark belastender Umgebung müssen Getriebe oder Getriebemotor mit Rostschutzlack lackiert werden, bei Bedarf mit wasserabstoßendem Fett überziehen (besonders wichtig bei rotierenden Dichtringsitzen und Wellenenden).

Wenn möglich, Getriebe oder Getriebemotor mit geeigneten Mitteln vor direkter Sonneneinstrahlung und vor Witterungsverhältnissen schützen: Dieser Schutz ist bei senkrecht angeordneten langsam- oder schnelllaufenden Wellen bzw. bei senkrecht aufgestelltem Motor mit obenliegenden Lüfter **unerlässlich**.

Bei Umgebungstemperatur über 40 °C bzw. unter 0 °C, bitte rückfragen.

Bevor man den elektrischen Anschluss des Getriebemotors vornimmt, muss man sich vergewissern, dass die Spannung des Motors mit der Netzspannung übereinstimmt.

Bei verkehrtem Drehsinn sind zwei Zuleitungsphasen zu vertauschen.

Wenn der Anlauf im Leerlauf bzw. mit sehr geringer Belastung erfolgt und wenn ein sanfter Anlauf, geringer Anzugsstrom und mäßige Beanspruchungen gefordert werden, so ist die Stern-Dreieck-Einschaltung anzuwenden.

Bei voraussichtlich längeren Überbelastungen, Stößen oder Hemmfahrt müssen Motorschutzschalter, elektronische Drehmomentbegrenzer, Hydraulik- und Sicherheitskupplungen, Kontrolleinheiten oder andere gleichwertige Schutzvorrichtungen eingebaut werden.

**Im Allgemeinen ist es notwendig, den Motor durch geeigneten magnetothermischen Schalter zu schützen;** bei Betrieb mit hoher Einschaltzahl unter Last den Motor mit (im Motor eingebauten) **Thermorelais** schützen; das Thermorelais ist nicht geeignet, da es zu höheren Werten als denjenigen des Motornennstroms eingestellt werden sollte.

**Die etwaigen Thermofühler müssen zu den Hilfssicherheitskreisen verbunden werden.**

Die durch die Schaltrelais verursachten Spannungsspitzen durch den Einsatz von Varistoren begrenzen.

**Achtung! Die Lebensdauer der Lager und der gute Betrieb der Wellen und Kupplungen hängen auch von der Präzision der Ausfluchtung zwischen den Wellen ab.** Das Getriebe einwandfrei mit dem Motor (wenn nötig durch Unterlegung) und der angetriebenen Maschine ausfluchten und möglichst immer elastische Kupplungen zwischen-schalten.

Wenn ein unvorhergesehener Schmiermittelverlust schwere Beschädigungen verursachen kann, die Häufigkeit der Kontrollmaßnahmen erhöhen bzw. entsprechende Überwachungsgeräte einbauen (z.B.: Standfernanzeige, Schmiermittel für die Lebensmittelindustrie, usw.).

In verunreinigten Arbeitsbereichen muss die Schmiermittelverschmutzung durch die Dichtringe oder etwas anderes auf wirksame Weise vorgebeugt werden.

Die Inbetriebnahme des Getriebes oder des Getriebemotors darf nur bei Einsatz auf eine Maschine erfolgen, die der EG-Richtlinie 98/37 und ihren folgenden Neubearbeitungen entspricht.

Bei Brems- oder Sondermotoren die gesonderten Unterlagen anfordern.

### Einbau von Maschinenelementen auf die Wellenenden

Für die Bohrung der auf Wellenende aufgezogenen Elemente wird die Toleranz H7 empfohlen. Für schnelllaufende Wellenenden mit  $D \geq 55$  mm kann die Toleranz G7 gewählt werden, vorausgesetzt, dass mit gleichmäßiger und leichter Belastung gearbeitet wird. Für langsamlaufende Wellenenden ist die Toleranz **K7** zu wählen, außer wenn es mit gleichmäßiger und leichter Belastung nicht gearbeitet wird. Andere Angaben nach Tabelle «Wellenende» (Kap. 20).

## 21 - Installation and maintenance

### General

Be sure that the structure on which gear reducer or gearmotor is fitted is plane, levelled and sufficiently dimensioned in order to assure fitting stability and vibration absence, keeping in mind all transmitted forces due to the masses, to the torque, to the radial and axial loads.

Position the gear reducer or gearmotor so as to allow a free passage of air for cooling both gear reducer and motor (especially at gear reducer and motor fan sides).

If there is fan on the gear reducer verify that there is sufficient space allowing for adequate circulation of cooling air also after fitting coupling protection. If a coupling protection is fitted smooth the coupling hub, if necessary.

Avoid: any obstruction to the air-flow; heat sources near the gear reducer that might affect the temperature of cooling-air and of gear reducer for radiation; insufficient air recycle or any other factor hindering the steady dissipation of heat.

Mount the gear reducer so as not to receive vibrations.

When external loads are present use pins or locking blocks, if necessary.

When fitting gear reducer and machine and/or gear reducer and eventual flange **B5** it is recommended to use **locking adhesives** such as **LOCTITE** on the fastening screws (also on flange mating surfaces).

For outdoor installation or in a hostile environment protect the gear reducer or gearmotor with anticorrosion paint. Added protection may be afforded by water-repellent grease (especially around the rotary seating of seal rings and the accessible zones of shaft end).

Gear reducers and gearmotors should be protected wherever possible, and by whatever appropriate means, from solar radiation and extremes of weather; weather protection **becomes essential** when high or low speed shafts are vertically disposed, or where the motor is installed vertical with fan uppermost.

For ambient temperatures greater than 40 °C or less than 0 °C, consult us.

Before wiring-up the gearmotor, make sure that motor voltage corresponds to input voltage. If the direction of rotation is not as desired, invert two phases at the terminals.

Star-delta starting should be adopted for starting on no load (or with a very small load) and/or when the necessity is for smooth starts, low starting current and limited stresses.

If overloads are imposed for long periods of time, or if shocks or danger of jamming are envisaged, then motor-protections, electronic torque limiters, fluid couplings, safety couplings, control units or other suitable devices should be fitted.

**Usually protect the motor with a thermal cut-out;** however, where duty cycles involve a high number of on-load starts, it is necessary to utilise **thermal probes** for motor protection (fitted on the wiring); thermal cut-out is unsuitable since its threshold must be set higher than the motor nominal current of rating.

**Connect thermal probes, if any, to auxiliary safety circuits.**

Use varistors to limit voltage peaks due to contactors.

**Warning! Bearing life, good shaft and coupling running depend on alignment precision between the shafts.** Carefully align the gear reducer with the motor and the driven machine (with the aid of shims if need be), interposing flexible couplings whenever possible.

Whenever a leakage of lubricant could cause heavy damages, increase the frequency of inspections and/or envisage appropriate control devices (e.g.: remote oil level gauge, lubricant for food industry, etc.).

In polluting surroundings, take suitable precautions against lubricant contamination through seal rings or other.

Gear reducer or gearmotor should not be put into service before it has been incorporated on a machine which is conform to 98/37/EEC directive.

For brake or non-standard motors, consult us for specific information.

### Fitting of components to shaft ends

It is recommended that the bore of parts keyed to shaft ends is machined to H7 tolerance; G7 is permissible for high speed shaft ends  $D \geq 55$  mm, provided that load is uniform and light; for low speed shaft ends, tolerance must be **K7** when load is not uniform and light. Other details are given in the «Shaft end» table (ch. 20). Before mounting, clean mating surfaces thoroughly and lubricate against seizure and fretting corrosion.

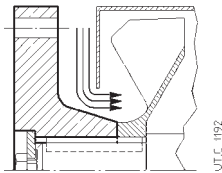

## 21 - Aufstellung und Wartung

Vor der Montage alle Kontaktflächen gründlich reinigen und schmieren, um Freierscheinungen und Berührungsanrostung zu vermeiden. Sowohl Montage als Demontage werden mit Hilfe von **Zugbolzen** und **Abziehern** vorgenommen, indem man sich der Gewindebohrung am Wellenkopfende bedient; bei Passungen H7/m6 und K7/j6 ist eine Warmmontage zu empfehlen, wobei das aufzuziehende Element auf  $80 \div 100$  °C erhitzt wird.

### Langsamlaufende Hohlwelle

Zur Demontage der langsamlaufenden Hohlwelle (erster Arbeitsvorgang beim Getriebeausbau) die Passfedernut gem. Abb. zur zwischenlaufenden Welle ausrichten und die Welle an der Seite der Bezugsrille (s. Kap. 20) schieben.

Der Maschinenzapfen, auf welchen die Hohlwelle des Getriebes aufgezogen wird, sollte je nach Bedarf mit Toleranzen h6, j6 oder k6 ausgeführt werden. Andere Angaben können aus dem Abschnitt «Wellenenden» und «Maschinenzapfen» (Kap. 20) entnommen werden.

Zur **Montage und Demontage** der Getriebe Größen 64 ... 360 (mit Sicherungsringnut) die Abb. a, b befolgen (außer MR 31 100 mit Motorgröße 112 und 31 125 mit Motorgröße 132; bitte rückfragen).

Bei MR 31 64 ... 81 muss man vorher die Scheibe mit Schraube und Seegering in die Getriebehohlwelle (auf der Motorgegenseite) und dann auf Maschinenzapfen montieren.

Zur Axialbefestigung nach dem in den Abb. c, d angegebenen Schema vorgehen. Für die Größen 64 ... 360, bei Maschinenzapfen ohne Absatz (untere Hälfte der Abb. d) zwischen Sicherungsring und Zapfen Distanzbuchse einfügen.

**Spannringe** (Größen 40 ... 63, Abb. e) oder **Spannbuchse** (Größen 64 ... 360, Abb. f) gestatten eine leichtere und genaue Montage bzw. Demontage und eine spielfreie Verbindung zwischen Passfeder und Nut, Reibungssystem nach ATEX.

Die Spannringe oder die Spannbuchse nach der Montage einziehen (bei MR 31 64 ... 81 die Buchse auf Maschinenzapfen oder in die Hohlwelle vor der Montage montieren. Beachten Sie die Orientierung der Passfeder), wobei der Maschinenzapfen den Angaben von Kap. 20 (oder 22 bei langsamlaufender Hohlwelle: abgestufter, mit Spannsatz) entsprechen muss. Kein Molybdänsulfid oder kein entsprechendes Schmiermittel zur Schmierung der Berührungsflächen anwenden. Für die Befestigung der Schraube empfehlen wir **Starkkleber** LOCTITE 601. Bei senkrechter **Hängebefestigung** bitte rückfragen.

Bei Axialbefestigung mit Spannringen bzw. Spannbuchse – besonders bei schweren Arbeitszyklen, mit häufigen Bewegungsumkehrungen – nach einigen Betriebsstunden das Spanndrehmoment nachprüfen und eventuell den Starkkleber wiederanwenden.

Auf Anfrage (Kap. 22) sind die **Scheibe** zur Montage, Demontage (außer Größen 40 ... 63) und Getriebeaxialbefestigung mit bzw. ohne **Spannringen** oder **Spannbuchse** (Abmessungen s. Tabelle) oder die langsamlaufende Hohlwelle mit **Spannsatz** (Abmessungen s. Kap. 22) und der **Schutzdeckel** der langsamlaufenden Hohlwelle erhältlich. Die mit dem Sicherungsring in Berührung stehenden Teile müssen mit scharfen Kanten ausgeführt werden.

Bei etwaigen Personen und Sachschäden wegen Fall oder vorstehender Teile der Getriebe ist es notwendig, **folgende Sicherheitsmaßnahmen** zu nehmen:

- gegen die Drehung oder das Ausziehen des Getriebes aus dem Maschinenzapfen wegen des zufälligen Bruchs der Reaktionsstütze;
- gegen den zufälligen Bruch des Maschinenzapfens.

## 21 - Installation and maintenance

Installing and removal operations should be carried out with **pullers** and **jacking screws** using the tapped hole at the shaft butt-end; for H7/m6 and K7/j6 fits it is advisable that the part to be keyed is preheated to a temperature of  $80 \div 100$  °C.

### Hollow low speed shaft

In order to remove the hollow low speed shaft (this is the first operation to perform when disassembling the gear reducer) turn the shaft until the keyway is facing the intermediate shaft, as shown in the drawing alongside, and push the shaft from the reference groove side (see ch. 20).

For the shaft end of machines where the hollow shaft of the gear reducer is to be keyed, h6, j6 or k6 tolerances are recommended (according to requirements). Other details are given under «Shaft end» and «Shaft end of driven machine» (ch. 20).

In order to have an easier **installing and removing** of gear reducer sizes 64 ... 360 with circlip groove proceed as per the drawings a, b, respectively (excluding MR 31 100 with motor size 112 and 31 125 with motor size 132;

UT. C 322

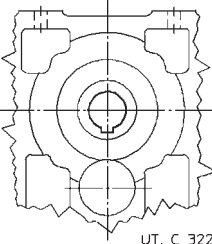

consult us).

For MR 31 64 ... 81 first insert the washer with screw and the circlip into gear reducer hollow shaft (on motor opposite side); then mount on machine shaft end.

The system illustrated in the fig. c, d is good for axial fastening.

For sizes 64 ... 360, when shaft end of driven machine has no shoulder a spacer may be located between the circlip and the shaft end itself (as in the lower half of the fig. d).

The use of **locking rings** (sizes 40 ... 63, fig. e), or of **locking bush** (sizes 64 ... 360, fig. f) will permit easier and more accurate installing and removing and to eliminate backlash between key and keyway, friction system **complying** with ATEX.

The locking rings or the locking bush are fitted after mounting (for MR 31 64 ... 81 insert the bush onto machine shaft end or into hollow shaft before mounting; pay attention when positioning the keyway); the shaft end of the driven machine must be as prescribed at ch. 20 (or 22 in case of hollow low speed shaft: stepped, with locking assembly). Do not use molybdenum bisulphide or equivalent lubricant for the lubrication of the parts in contact. When tightening the bolt, we recommend the use of a **locking adhesive** such as LOC-TITE 601. For **vertical ceiling-type** mounting, contact us.

In case of axial fastening with locking rings or bush – especially when having heavy duty cycles, with frequent reversals – verify, after some hours of running, the bolt tightening torque and eventually apply the locking adhesive again.

A **washer** for installing, removing (excluding sizes 40 ... 63) and axial fastening of gear reducer (ch. 22) with or without **locking rings**, **locking bush** (dimensions shown in the table) or hollow low speed shaft with **shrink disc** (dimensions stated on ch. 22), and a **protection cap** for the hollow low speed shaft can be supplied on request. Parts in contact with the circlip must have sharp edges.

Whenever personal injury or property damage may occur, foresee **adequate supplementary protection devices** against:

- rotation or unthreading of the gear reducer from shaft end of driven machine following to accidental breakage of the reaction arrangement;
- accidental breakage of shaft end of driven machine.

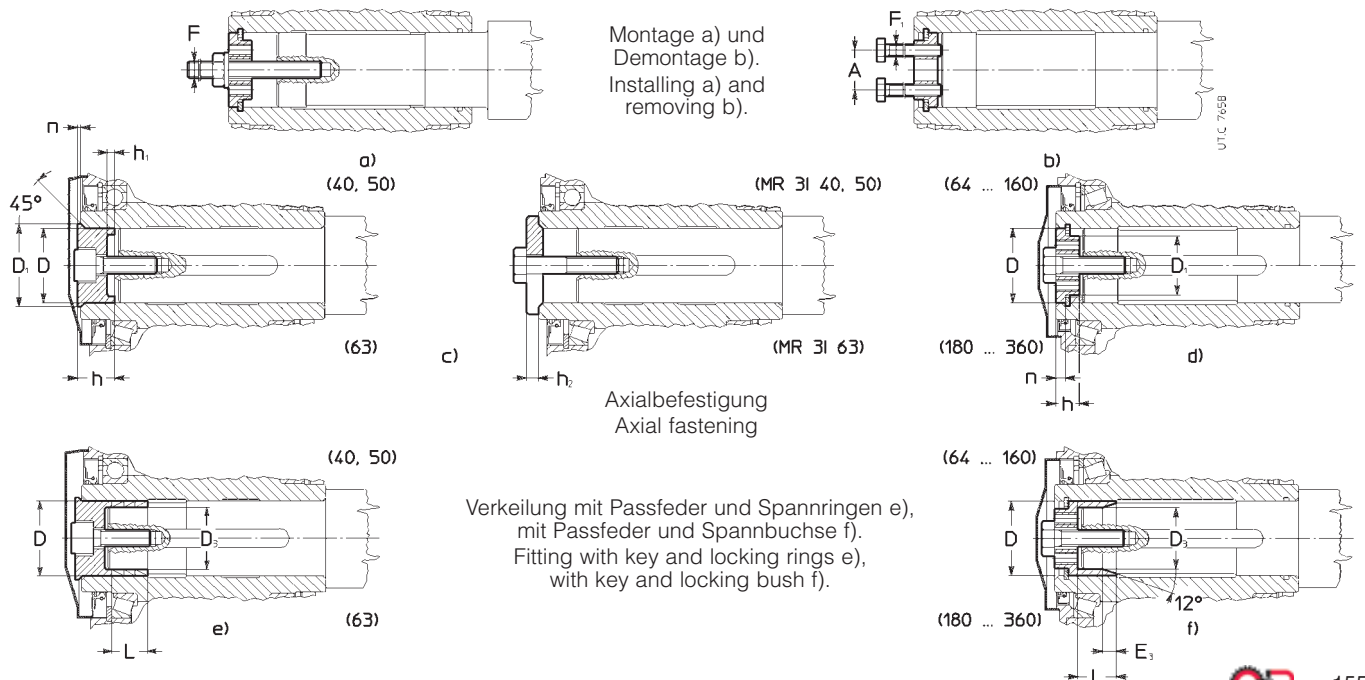

Getriebe- größe Gear reducer size	A	D Ø	D <sub>1</sub> Ø	D <sub>3</sub> Ø	E <sub>3</sub> ≈	F	F <sub>1</sub>	h	h <sub>1</sub>	h <sub>2</sub>	L	n	Axialbefestigung Bolt for axial fastening	
													UNI 5737-88	M [daN m] <sup>1)</sup>
<b>40</b>	—	19	22,5	15 <sup>4)</sup>	—	—	—	14,8	2,8	4	12,6 <sup>4)</sup>	1,1	M 8 × 25 <sup>2)</sup>	2,9
<b>50</b>	—	24	27,5	19 <sup>4)</sup>	—	—	—	14,8	2,8	4	12,6 <sup>4)</sup>	1,2	M 8 × 25 <sup>2)</sup>	3,5
<b>63</b>	—	30	34	25 <sup>4)</sup>	—	—	—	18,5	3,7	5	18,9 <sup>4)</sup>	1,4	M 10 × 30 <sup>2)</sup>	4,3
<b>64</b>	18	32	23	27	9	M 10	M 6 <sup>5)</sup>	10	—	—	19	6	M 10 × 35	4,3
<b>80</b>	18	38	27	32	11	M 10	M 6 <sup>5)</sup>	12	—	—	23	6	M 10 × 35 <sup>3)</sup>	5,1
<b>81</b>	18	40	28	34	11	M 10	M 6	12	—	—	23	6	M 10 × 35 <sup>3)</sup>	5,3
<b>100</b>	23	48	35	41	13	M 12	M 8	14	—	—	28	7	M 12 × 45 <sup>3)</sup>	9,2
<b>125</b>	30	60	45	52	15	M 14	M 10	16	—	—	35	7	M 14 × 45 <sup>3)</sup>	17
<b>140</b>	36	70	54	62	15	M 16	M 12	19	—	—	40	8	M 16 × 50	21
<b>160</b>	45	80	63	70	20	M 20	M 12	19	—	—	45	8	M 20 × 60	34
<b>180</b>	49	90	72	80	20	M 20	M 16	23	—	—	49	9	M 20 × 60 <sup>3)</sup>	43
<b>200</b>	56	100	81	88	24	M 24	M 16	23	—	—	52	10	M 24 × 70	66
<b>225</b>	64	110	89	98	24	M 24	M 16	24	—	—	60	10	M 24 × 70 <sup>3)</sup>	83
<b>250</b>	72	125	102,5	110	30	M 30	M 20	28	—	—	67	11	M 30 × 90	135
<b>280</b>	87	140	117	125	30	M 30	M 20	30	—	—	76	12	M 30 × 90 <sup>3)</sup>	166
<b>320, 321</b>	97	160	133,5	140	41	M 36	M 24	33	—	—	86	13	M 36 × 110	257
<b>360</b>	117	180	153	160	41	M 36	M 24	36	—	—	95	14	M 36 × 110 <sup>3)</sup>	315

1) Spanndrehmoment für Spannringe oder Spannbuchse.  
 2) UNI 5931-84. Für MR 3I: M 8 × 35 und M 10 × 40 UNI 5737-88.  
 3) Spannbuchse: M 10 × 35, M 12 × 45, M 14 × 45, Klasse 10.9; M 20 × 65, M 24 × 80 und M 30 × 100 UNI 5737-88 Klasse 10.9; M 36 × 120 UNI 5931-84 Klasse 10.9.  
 4) Spannbuchse für MR 3I nicht möglich.  
 5) Für die Demontage von MR 3I nicht anwendbar.

1) Tightening torque for locking rings or bush.  
 2) UNI 5931-84. For MR 3I: M 8 × 35 and M 10 × 40 UNI 5737-88.  
 3) For locking bush: M 10 × 35, M 12 × 45, M 14 × 45, class 10.9; M 20 × 65, M 24 × 80 and M 30 × 100 UNI 5737-88 class 10.9; M 36 × 120 UNI 5931-84 class 10.9.  
 4) Locking bush is not possible for MR 3I.  
 5) It cannot be used for the disassembly of MR 3I.

### Schmierung

Die Zahnradpaare sind ölbadeschmiert; davon ist die erste Übersetzungsstufe der Stirnradgetriebe mit Zahnradgetriebe **3I** und die ersten zwei Übersetzungsstufen der Getriebemotoren **4I** Größen ≤125, Bauform V5 ausgenommen, die mit Fett «**lebensdauer geschmiert**» sind (SHELL Tivela Compound A). Auch die Lager sind sowohl ölbadeschmiert als spritzgeschmiert. Davon sind die oberen Lager ausgenommen, welche durch eine Pumpe geschmiert (s. Kap. 22) oder mit Fett «lebensdauer geschmiert» sind (je nach Geschwindigkeit mit oder ohne NILOS-Ring).

**Größen 40 ... 81:** Die Getriebe werden mit **Synthetikölfüllung** (KLÜBER Klübersynth GH 6-220, MOBIL Glygoyle 30), – ohne Außenverunreinigungen – für «**Lebensdauerschmierung**» geliefert. Umgebungstemperatur 0 ÷ 40 °C mit Spitzen von -20 °C bis +50 °C.

**Wichtig:** Bauform nachprüfen: Wenn das Getriebe in einer verschiedenen Bauform als diejenige auf Typenschild angegeben montiert wird, könnte es – durch entsprechende Einfüllschraube – den Zusatz des Unterschieds zwischen den zwei auf Kap. 8, 10, 13 und 16 angegebenen Schmiermittelmengen erfordern.

**Größen 100 ... 360:** Die Getriebe werden **ohne Öl** geliefert; vor Inbetriebnahme **Mineralöl** (AGIP Blasias, ARAL Degol BG, BP-Energol GR-XP, ESSO Spartan EP, IP Mellana oil, MOBIL Mobilgear 600, SHELL Omala, TEXACO Meropa, TOTAL Carter EP) mit in Tabelle angegebenem ISO Viskositätsgrad bis zum angegebenen Ölstand einfüllen. Normalerweise bezieht sich der erste Drehzahlbereich auf das Zahnradgetriebe **I**, das zweite auf das Zahnradgetriebe **2I** und **CI**, das dritte auf das Zahnradgetriebe **3I**, **4I**, **C2I**, **ICI** und **C3I**, das vierte die **Kombinationen**.

Wenn Sie das Ölwechselintervall («Langzeit»), den Bereich der Umgebungstemperatur steigern u/o die Öltemperatur vermindern möchten, verwenden Sie **Synthetiköl** (Polyglykole: KLÜBER Klübersynth GH6 ..., MOBIL Glygoyle, SHELL Tivela S oil...; Polyalfaolefine, immer empfohlen, besonders bei Größen ≥ 200: AGIP Blasias SX, CASTROL Tribol 1510, ELF Reductelf SYNTHÈSE, ESSO Spartan SEP, KLÜBER Klübersynth EG4, MOBIL SHC Molykote L11...) mit in Tab. angegebenem ISO-Viskositätsgrad.

1) Die Schmiermittelmengen auf Kap. 8, 10, 13, 16 sind nur als Anzeigemengen zu betrachten. Die in das Getriebe hinzuzufüllende genaue Ölmenge hängt vom Niveau ab.

### ISO-Viskositätsgrad

Mittelwert [cSt] der kinematischen Viskosität bei 40 °C.

Drehzahl n <sub>2</sub> min <sup>-1</sup>	Umgebungstemperatur <sup>1)</sup> [°C]		
	Mineralöl		Synthetiköl
	0 ÷ 20	10 ÷ 40	0 ÷ 40
> <b>224</b>	150	150	150
<b>224</b> ÷ <b>22,4</b>	150	220	220
<b>22,4</b> ÷ <b>5,6</b>	220	320	320
< <b>5,6</b>	320	460	460

1) Temperaturunterschreitungen von 10 °C (20 °C für Synthetiköl) oder Temperaturüberschreitungen von 10 °C sind zugelassen.

Bei Dauerbetrieb empfehlen wir Synthetiköl in folgenden Fällen:  
 – R ICI, MR C3I 100, 125 und MR ICI 100 ... 200 Bauform B6;  
 – R I 100 mit n<sub>2</sub> ≥ 375 min<sup>-1</sup>;  
 – R CI 100 mit n<sub>2</sub> ≥ 150 min<sup>-1</sup>;  
 – R 2I und MR 2I 125 mit i<sub>N</sub> ≤ 12,5, Bauform B7, n<sub>1</sub> ≥ 950 min<sup>-1</sup>;  
 – MR ICI 200 mit Motorgröße 225;  
 – Getriebe und Getriebemotoren mit gekennzeichneten Größen

### Lubrication

Gear pairs are oil-bath lubricated with the exception of the first reduction stage in parallel shaft gear reducers train of gears **3I** and the first two reduction stages of gearmotors **4I** sizes ≤ 125 in V5 mounting position, which are lubricated «**for life**» with grease (SHELL Tivela Compound A). Bearings are either oil-bathed or splashed with the exception of the top bearings which are lubricated with a pump (see ch. 22) or lubricated «for life» with grease (with or without NILOS ring according to speed).

**Sizes 40 ... 81:** the gear reducers are supplied **filled with synthetic oil** (KLÜBER Klübersynth GH 6-220, MOBIL Glygoyle 30) providing lubrication «**for life**» – assuming pollution-free surroundings. Ambient temperature range 0 ÷ 40 °C with peaks of -20 °C and +50 °C.

**Important:** verify mounting position keeping in mind that if gear reducer is installed in a mounting position differing from the one stated on name plate, it could need the addition – through the proper hole – of the difference between the two lubricant quantities as shown in ch. 8, 10, 13 and 16.

**Sizes 100 ... 360:** gear reducers are supplied **without oil**; before putting into service, fill to the specified level<sup>1)</sup> with **mineral oil** (AGIP Blasias, ARAL Degol BG, BP-Energol GR-XP, ESSO Spartan EP, IP Mellana oil, MOBIL Mobilgear 600, SHELL Omala, TEXACO Meropa, TOTAL Carter EP) having the ISO viscosity grade given in the table. Under normal conditions the first speed range is for train of gears **I**, the second is for trains of gears **2I** and **CI**, the third is for trains of gears **3I**, **4I**, **C2I**, **ICI** and **C3I**, while the fourth is for **combined units**.

When it is required to increase oil change interval («long life»), the ambient temperature range, and/or reduce oil temperature, use **synthetic oil** (with polyglycol basis: KLÜBER Klübersynth GH6 ..., MOBIL Glygoyle, SHELL Tivela S oil...; with polyalphaolefines basis, always suggested especially for sizes ≥ 200: AGIP Blasias SX, CASTROL Tribol 1510, ELF Reductelf SYNTHÈSE, ESSO Spartan SEP, KLÜBER Klübersynth EG4, MOBIL SHC Molykote L11 ...) having ISO viscosity grade as indicated in the table.

1) The lubricant quantities contained in ch. 8, 10, 13, 16 are approximate and indicative for provisioning. The exact oil quantity the gear reducer is to be filled with is definitely given by the level.

### ISO viscosity grade

Mean kinematic viscosity [cSt] at 40 °C.

Speed n <sub>2</sub> min <sup>-1</sup>	Ambient temperature <sup>1)</sup> [°C]		
	mineral oil		synthetic oil
	0 ÷ 20	10 ÷ 40	0 ÷ 40
> <b>224</b>	150	150	150
<b>224</b> ÷ <b>22,4</b>	150	220	220
<b>22,4</b> ÷ <b>5,6</b>	220	320	320
< <b>5,6</b>	320	460	460

1) Peaks of 10 °C above and 10 °C (20 °C for synthetic oil) below the ambient temperature range are acceptable.

For continuous duty, the use of synthetic oil is recommended in the following cases:  
 – R ICI, MR C3I 100, 125 und MR ICI 100 ... 200 mounting position B6;  
 – R I 100 with n<sub>2</sub> ≥ 375 min<sup>-1</sup>;  
 – R CI 100 with n<sub>2</sub> ≥ 150 min<sup>-1</sup>;  
 – R 2I und MR 2I 125 with i<sub>N</sub> ≤ 12,5, mounting position B7, n<sub>1</sub> ≥ 950 min<sup>-1</sup>;  
 – MR ICI 200 with motor size 225;  
 – gear reducers and gearmotors with size and mounting position



## 21 - Aufstellung und Wartung

und Bauformen (s. Kap. 8, 10, 13, 16) und Kegelstirnradgetriebe mit beidseitig vorstehender schnelllaufender Welle.

Das in der Tabelle angeführte **Ölwechselintervall** ist in Abwesenheit von Außenverunreinigungen als Richtwert zu betrachten. Bei starken Überbelastungen, die Richtwerte halbieren.

Öltemperatur [°C]	Ölwechselintervall [h]	
	Mineralöl	Synthetiköl
≤ 65	8 000	25 000
65 ÷ 80	4 000	18 000
80 ÷ 95	2 000	12 500
95 ÷ 110 <sup>1)</sup>	—	9 000

1) Werte nur für Nicht-Dauerbetrieb gültig.

Niemals Synthetiköle unterschiedlicher Fabrikate miteinander vermengen; ein anderes Öl erst nach gründlichem Durchspülen einfüllen.

**Kombieinheiten Getriebemotoren:** Getrennte Schmierung; es gelten daher die Vorschriften der einzelnen Getriebe.

**Dichtringe:** Die Lebensdauer hängt von vielen Faktoren wie Umlaufgeschwindigkeit, Temperatur, Umweltbedingungen, usw.; sie kann in der Größenordnung von 3 150 bis 25 000 h schwanken.

**Achtung:** Bei Getriebegrößen 100 ... 360 muss das Aggregat vor Lockern der Öleinfüllschraube mit Ventil (Symbol ) gut auskühlen. Vorsicht beim Öffnen.

### Auswechslung des Motors

Da die Getriebemotoren mit **Normmotoren** ausgestattet sind, ist die Auswechslung des Motors — im Störfalle — weitestgehend erleichtert. Es sind nur folgende Vorschriften zu beachten:

- Darauf achten, dass die Motoren mit Präzisionspassungen ausgeführt sind (UNEL 13501-69; DIN 42955);
- die Passflächen sorgfältig reinigen;
- die Passfeder überprüfen und bei Bedarf derart abflachen, sodass zwischen ihrer Oberseite und dem Boden der Passfedernut der Bohrung ein Spiel von 0,1 ÷ 0,2 mm verbleibt; wenn die Wellennut ohne Absatz ist, die Passfeder verstimmen;

### Stirnradgetriebemotoren MR 2I, MR 3I (Größen 140 ... 360) und Kegelstirnradgetriebemotoren MR CI, MR C2I:

- sich vergewissern, dass die Passtoleranz (Schiebesitz) Bohrung/Wellenende G7/j6 bei D ≤ 28 mm, F7/k6 bei D ≥ 38 mm beträgt;
- die Passflächen schmieren, um Berührungsanrostung zu vermeiden;

### Stirnradgetriebemotor 2I, 3I mit Motorgrößen 200 ... 315 und Getriebemotoren 2I, CI in Ausführung «Viereckiger Flansch für Servomotoren», zur Demontage s. folgende Anweisungen:

- Die Schlüsselbohrung mit der Spannscheibe des Stellrings fluchten;
- Die Spannschraube und den Stellring lösen;
- den Motor demontieren;

Die Motormontage wird wie oben aber in Gegenrichtung ausgeführt.

### Stirnradgetriebemotoren MR 3I, 4I (Größen 54 ... 125) und Kegelstirnradgetriebemotoren MR ICI, C3I; bei koax. Stirnradgetrieben, die mit Stirnrad- und Kegelstirnradgetrieben (Kombieinheiten) gekuppelt sind:

- sich vergewissern, dass die Passtoleranz (standard gesperrt) Bohrung/Wellenende K6/j6 bei D ≤ 28 mm, J6/k6 bei D ≥ 38 mm beträgt; die Länge der Passfeder beträgt mindestens 0,9 die Breite des Ritzels;
- darauf achten, dass die Motoren Lager und Maß «S» wie in der folgenden Tabelle haben;
- Distanzstück (mit Dichtmasse; sich vergewissern, dass zwischen Passfedernut und Motorwellenabsatz ein geschliffener Gewinderaum von mindestens 1,5 mm ist) und Ritzel (letzteres wird auf 80 ÷ 100 °C erwärmt) am Motor anbringen und mit kopfseitiger Schraube oder Stellring festklemmen;
- die Ritzelverzahnung, den rotierenden Dichtringsitz und den Dichtring selbst mit Fett schmieren. Die Montage mit ganz besonderer Sorgfalt vornehmen.

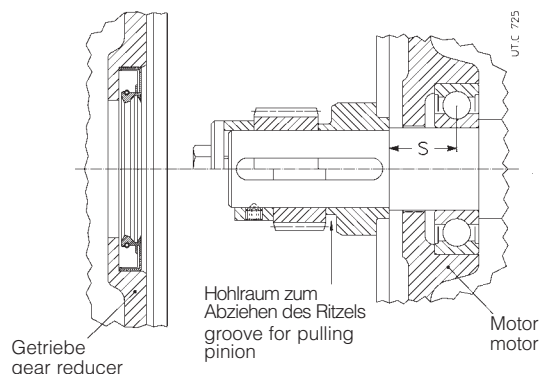

## 21 - Installation and maintenance

marked with  (see ch. 8, 10, 13, 16) and right angle shaft gear reducers with double extension high speed shaft.

An overall guide to **oil-change interval** is given in the table, and assumes pollution-free surroundings. Where heavy overloads are present, halve the values.

Oil temperature [°C]	Oil-change interval [h]	
	mineral oil	synthetic oil
≤ 65	8 000	25 000
65 ÷ 80	4 000	18 000
80 ÷ 95	2 000	12 500
95 ÷ 110 <sup>1)</sup>	—	9 000

1) Values admissible for not continuous duty, only.

Never mix different makes of synthetic oil; if oil-change involves switching to a type different from that used hitherto, then give the gear reducer a through clean-out.

**Combined gearmotor units:** lubrication remains independent, thus data relative to each single gear reducer hold good.

**Seal rings:** duration depends on several factors such as dragging speed, temperature, ambient conditions, etc.; as a rough guide; it can vary from 3 150 to 25 000 h.

**Warning:** for gear reducers sizes 100 ... 360, before unscrewing the filler plug with valve (symbol ) wait until the unit has cooled and then open with caution.

### Motor replacement

As all gearmotors are fitted with **standardized** motors, motor replacement in case of breakdown is extremely easy. Simply observe the following instructions:

- ensure that motor mating surfaces are machined under accuracy rating (UNEL 13501-69; DIN 42955);
- clean surfaces to be fitted, thoroughly;
- check, and if necessary, lower the parallel key so as to leave a clearance of 0,1 ÷ 0,2 mm between its tip and the bottom of the keyway of the hole; when shaft keyway is without end, lock the key with a pin;

### parallel shaft gearmotors MR 2I, MR 3I (sizes 140 ... 360) and right angle shaft gearmotors MR CI, MR C2I:

- check that the fit-tolerance of (push-fit) hole-shaft end is G7/j6 for D ≤ 28 mm, F7/k6 for D ≥ 38 mm;
- lubricate surfaces to be fitted against fretting corrosion;

### gearmotors 2I, 3I with motor size 200 ... 315 and gearmotors 2I, CI with special design «Square flange for servomotors», proceed as follows for disassembling:

- align the key through hole with the tightening screw of the hub clamp;
  - loosen the tightening screw and consequently the hub clamp;
  - disassemble the motor;
- for the motor mounting proceed as above stated in the opposite direction:

### parallel shaft gearmotors MR 3I, 4I (sizes 40 ... 125) and right angle shaft gearmotors MR ICI, C3I; coaxial gearmotors coupled with parallel and right angle shaft gear reducers (combined units):

- check that the fit-tolerance of hole-shaft end (standard locking) is K6/j6 for D ≤ 28 mm, J6/k6 for D ≥ 38 mm; the length of the parallel key is to be at least 0,9 the face width of the pinion;
- ensure that motor bearings and overhangs (dimension S) are as shown in the table;
- mount the spacer (with rubber cement check that between keyway and motor shaft shoulder there is a grounded cylindrical part of at least 1,5 mm) and the pinion (the latter to be preheated to a temperature of 80 ÷ 100 °C) on the motor, locking the assembly with either a bolt to the shaft butt-end, or a stop collar;
- lubricate the pinion toothing, and the seal ring and its rotary seating with grease, assembling with extreme care.

Motorgröße Motor size	Min dynamische Belastbarkeit [daN] Min. dynamic load capacity [daN]		Max Maß 'S' Max dimension 'S' mm
	Vorn Front	Hinten Rear	
63	450	335	16
71	630	475	18
80	900	670	20
90	1 320	1 000	22,5
100	2 000	1 500	25
112	2 500	1 900	28
132	3 550	2 650	33,5
160	4 750	3 350	37,5
180	6 300	4 500	40
200	8 000	5 600	45
225	10 000	7 100	47,5

**Aufsteckbefestigungen**

Die Form und die Robustheit des Gehäuses gestatten **bemerkenswerte** Aufsteckbefestigungslösungen (für die lieferbaren Reaktionssysteme, s. Kap. 22 «Aufsteckbefestigungen»), z.B. auch Getriebemotoren mit Riemenantrieb, hydraulischer Kupplung; Lagerung der langsamlaufenden Welle, usw. Nachstehend führen wir einige bedeutsame Motorabstützungen und Aufsteckbefestigungen an, denen entsprechende Angaben zur Auswahl und Aufstellung beigefügt werden.

WICHTIG. Bei Aufsteckbefestigung muss der Getriebemotor sowohl radial als axial (auch bei Bauformen B3 ... B8) durch den Maschinenzapfen abgestützt werden. Der Drehung entgegenwirkend soll eine **axialfreie** Bindung sein, die ein genügend großes **Paarungsspiel** aufweist, um die immer vorhandenen kleinen Oszillationen zu gestatten, ohne dass auf dem Getriebemotor zusätzliche gefährliche Belastungen einwirken.

Die Gelenke und die gleitenden Teile mit geeigneten Produkten schmieren; für die Befestigung der Schrauben empfehlen wir Starkkleber LOCTITE 601.

Bei Aufsteckbefestigung mit elastischer Bindung, Größen 140 ... 360 C21, 21, 31, Bauform B3 oder B8, sich vergewissern, dass die Oszillation des Gehäuses während des Betriebs die waagrechte Position nach oben nicht überschreitet.

**Shaft-mounting arrangements**

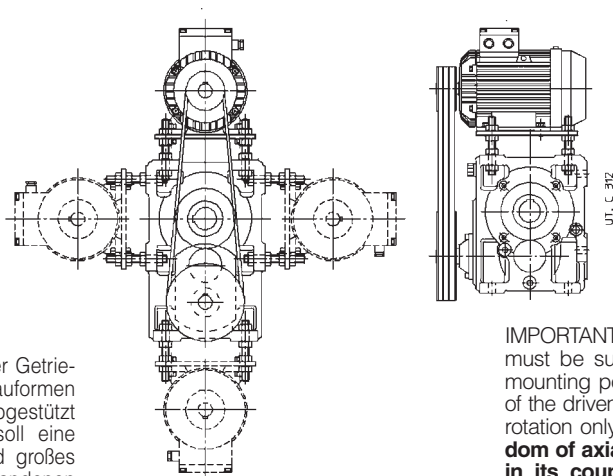

The strength and shape of the casing offer **advantageous** possibilities for shaft mounting for several reaction arrangements which can be supplied, see ch. 22 «Shaft mounting arrangements») even — for instance — in the case of gearmotor with belt drive, hydraulic coupling; low speed shaft bearings, etc. A few possible examples of shaft mounting arrangements are shown here as pointers, alongwith the relative details as to selection, and installation.

**IMPORTANT.** When shaft mounted, the gearmotor must be supported both axially and radially (for mounting position B3 ... B8, too) by the shaft end of the driven machine, as well as anchored against rotation only, by means of a reaction having **freedom of axial movement** and sufficient **clearance in its couplings** to permit minor oscillations — always in evidence — without provoking dangerous overloads on the gearmotor.

Lubricate with proper products the hinges and the parts subject to sliding; when mounting the screws it is recommended to apply locking adhesives type LOCTITE 601.

In case of shaft-mounting arrangement with elastic constraint, for the sizes 140 ... 360 C21, 21, 31 in B3 or B8 mounting position, ensure that the casing oscillation, during the running, not overtake — towards the top — the horizontal position.

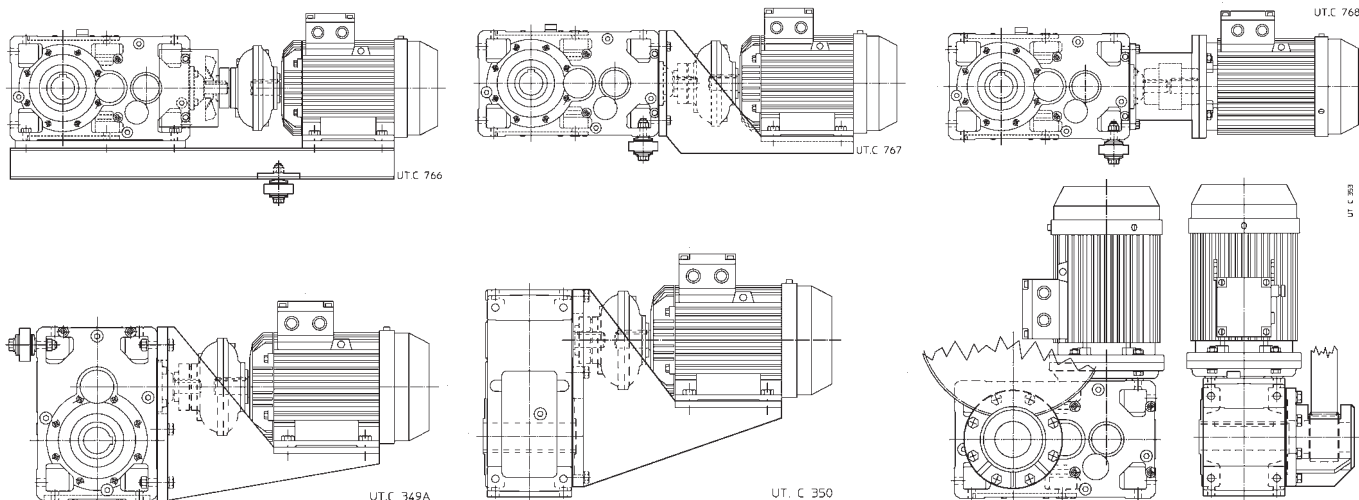

Halbelastisches und wirtschaftliches Reaktionssystem durch Mutterschraube mit Tellerfedern bei Größen  $\leq 125$  (Kap. 22), für niedrige Drehmomentswerte geeignet.

Semi-flexible and economic reaction arrangement, for sizes  $\leq 125$  (ch. 22), with bolt using disc springs, suitable for low torque values.

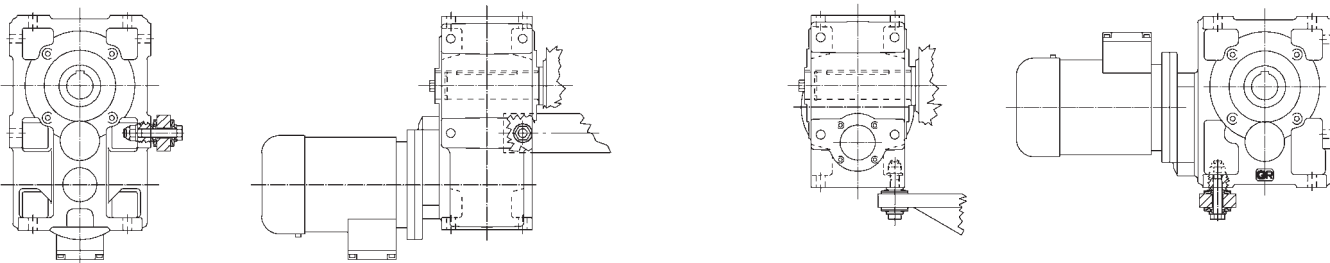

Halbelastisches und wirtschaftliches Reaktionssystem bei 21, 31, 41 Größen  $\leq 125$  (Kap. 22) mit **Aussparung** und Tellerfedern.

Semi-flexible reaction arrangement for 21, 31, 41 sizes  $\leq 125$  (ch. 22), using **reaction recess** and disc springs.

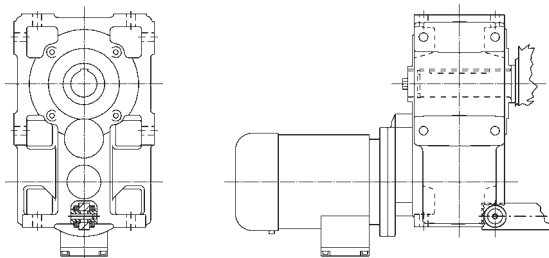

## 21 - Aufstellung und Wartung

Halbelastisches Reaktionssystem bei Größen CI 63 ... 100, ICI 63 ... 200, C3I 63 ... 125 (Kap. 22) mit Tellerfedern und Bügel.

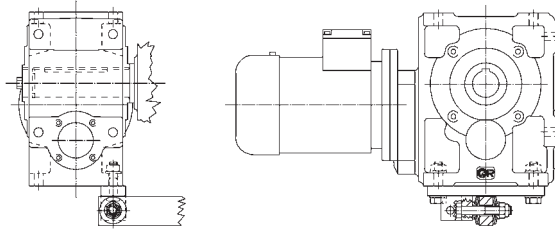

Semi-flexible reaction arrangement for sizes CI 63 ... 100, ICI 63 ... 200, C3I 63 ... 125 (ch. 22), using disc springs and bracket.

Steifes Reaktionssystem mit Drehmomentstütze bei Größen CI 63 ... 100, ICI 63 ... 200, C3I 63 ... 125 (Kap. 22) zur Verankerung mit variablem Abstand. Bei entgegengesetztem Drehsinn als angegeben, Drehmomentstütze um 180° drehen.

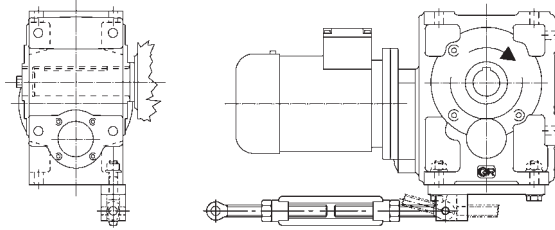

Rigid reaction arrangement for variable distance anchorage for sizes CI 63 ... 100, ICI 63 ... 200, C3I 63 ... 125 (ch. 22), using a torque arm. Where direction of rotation is opposite to the one shown in the drawing, turn the torque arm through 180°.

Reaktionssystem wie zuvor, jedoch elastisch für Größen CI 100, ICI 100 ... 200, C3I 100, 125 (Kap. 22); Einbau von Sicherheitsvorrichtungen gegen etwaige Überbelastungen möglich. Drehsinnunabhängig kann die elastische Drehmomentstütze um 180° gedreht werden.

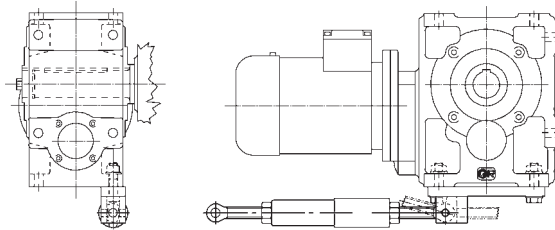

Rigid reaction arrangement for variable distance anchorage for sizes CI 100, ICI 100 ... 200, C3I 100, 125 (ch. 22), but using a flexible torque arm; safety devices may be installed to prevent accidental overloads. The flexible torque arm may be turned through 180° regardless of direction of rotation.

UTC 769

Elastisches und wirtschaftliches Reaktionssystem durch Mutterschraube mit Tellerfedern für Größen  $\geq 140$  ( $\geq 125$  bei CI; Kap. 22). Einbau von Sicherheitsvorrichtungen gegen etwaige Überbelastungen möglich. Eine steife und wirtschaftliche Aufsteckbefestigung mit 2 Bohrungen ist auch möglich: S. Kap. 22 «Zusätzliche Bohrungen des Gehäuses».

Flexible and economic reaction arrangement, for sizes  $\geq 140$  ( $\geq 125$  for CI; ch. 22), with bolt using disc springs. Safety devices may be installed to prevent accidental overloads. A rigid and economic shaft mounting with 2 holes is also possible: see ch. 22 «Additional casing holes».

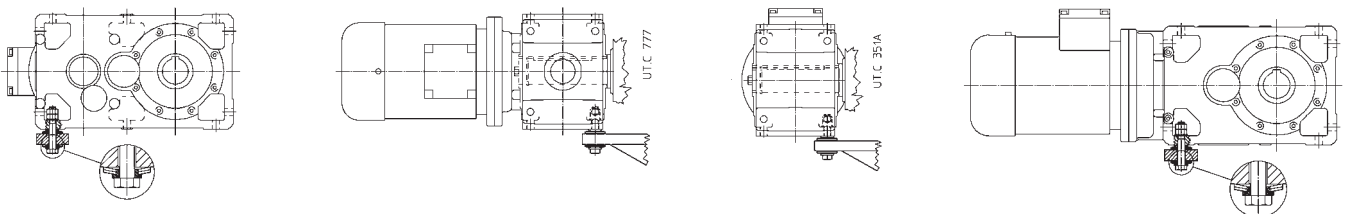

Elastisches Reaktionssystem durch Gummipuffer (Zeichnungen sind nur beispielhaft, aber die Gummipuffer müssen in Kontakt zum Getriebegehäuse positioniert werden). Einbau von Sicherheitsvorrichtungen gegen etwaige Überbelastungen möglich.

Flexible reaction arrangement using rubber buffers (drawings are only a rough guide, but rubber buffers are to be positioned in contact with gear reducer casing). Safety devices may be installed to prevent accidental overloads.

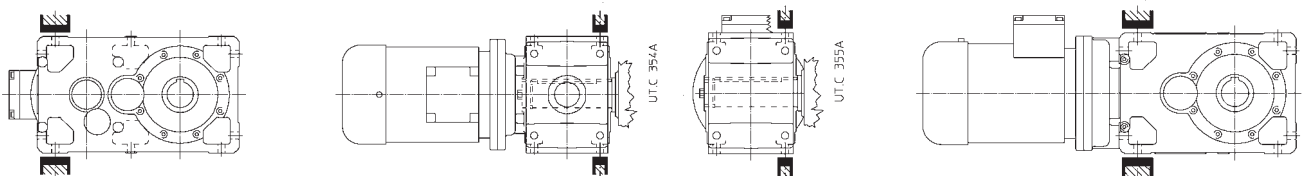

## 21 - Aufstellung und Wartung

Für die üblichen Fällen, wobei Gewichtskraft  $G$  parallel oder orthogonal zur Reaktionskraft  $R_R$  ist (s. unterliegendes Schema), findet die Berechnung der jeweiligen Reaktionskräfte folgendermaßen statt (den ungünstigsten Fall betrachten), das gilt auch für das lange Modell:

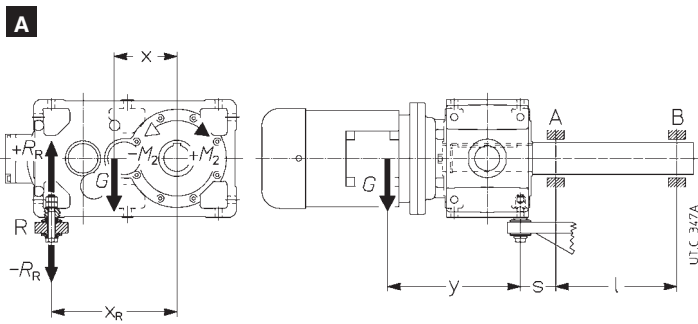
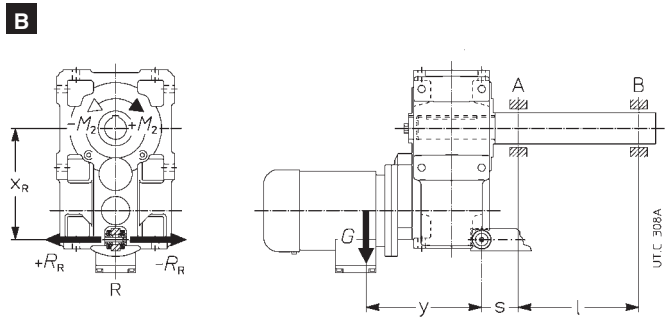
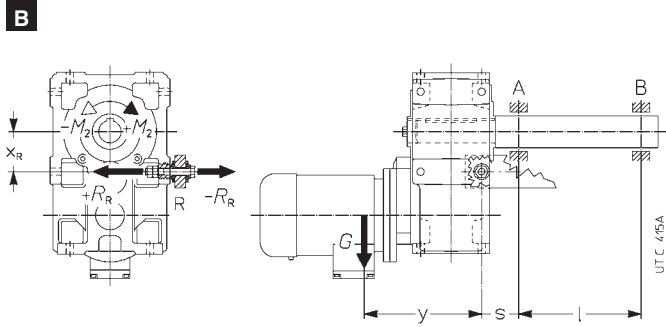

## 21 - Installation and maintenance

For the majority of normal cases, where weight force  $G$  is parallel or orthogonal to reaction  $R_R$  as illustrated in the drawings, reactions are calculated thus (verify the worst condition) valid for long model too:

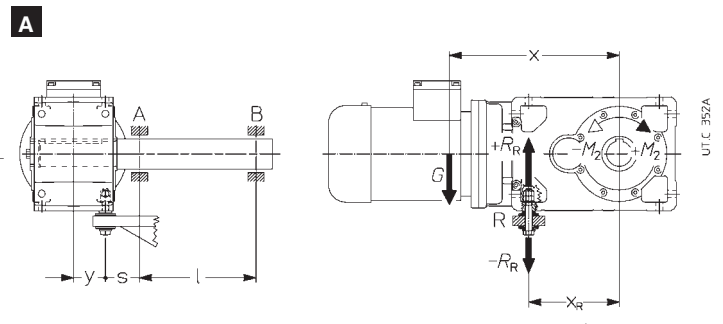
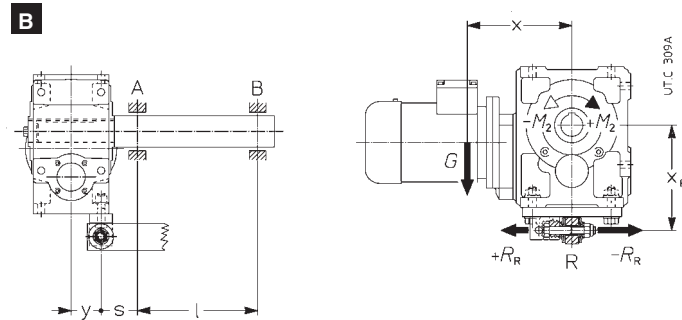
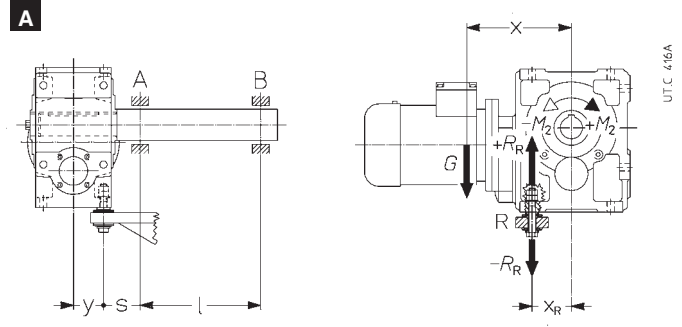

- $G$  [daN]: Gewichtskraft, zahlenmäßig ungefähr gleich der Masse des Getriebemotors (Kap. 13 oder 16);
- $M_2$  [daN m]: Abtriebsdrehmoment, je nach Drehsinn im Schema mit + oder – Vorzeichen zu berücksichtigen;
- $x$  [m]: Für Stirnradgetriebemotoren ist Maß  $x = 0$  (Schema B) oder  $x = 0,67 \cdot a$  (Schema A) (Kap. 13); für Kegelstirnradgetriebemotoren ist Maß  $x = G + 0,2 \cdot Y$  (Schema A oben und B) oder  $x = a + G + 0,2 \cdot Y$  (Schema A unten) (Kap. 16);
- $y$  [m]: Für Stirnradgetriebemotoren ist Maß  $y = 0,5 \cdot B + G + 0,2 \cdot Y$  (Kap. 13); Für Kegelstirnradgetriebemotoren ist Maß  $y = 0,5 \cdot B$  (Kap. 16);
- $x_R$  [m]: S. Kap. 13, 16, 22;
- $l, s$  [m]: Maß  $s$  so klein wie möglich halten.

- $G$  [daN]: weight force almost equal numerically to gearmotor mass (ch. 13 or 16);
- $M_2$  [daN m]: output torque expressed by + or – according to the direction of rotation in the drawing;
- $x$  [m]: for parallel shaft gearmotors dimension  $x = 0$  (B drawing) or  $x = 0,67 \cdot a$  (A drawing) (ch. 13); for right angle shaft gearmotors dimension  $x = G + 0,2 \cdot Y$  (upper A and B drawings) or  $x = a + G + 0,2 \cdot Y$  (lower A drawing) (ch. 16);
- $y$  [m]: for parallel shaft gearmotors dimension  $y = 0,5 \cdot B + G + 0,2 \cdot Y$  (ch. 13); for right angle shaft gearmotors dimension  $y = 0,5 \cdot B$  (ch. 16);
- $x_R$  [m]: see ch. 13, 16, 22;
- $l, s$  [m]: dimension  $s$  must be as short as possible.

1) Reaktionskraft  $R_R$  der Stütze R:

$$R_R = (1 / x_R) \cdot [G \cdot x + (\pm M_2)] \quad [\text{daN}]$$

2) Biegemoment  $M_{fA}$  im Schnitt von Lager A:

**A**  $M_{fA} = [G \cdot (y + s)] - [(\pm R_R) \cdot s]$

3) Radial-Reaktionskraft  $R_A$  von Lager A:

**A**  $R_A = \frac{1}{l} \{ [G \cdot (y + s + l)] - [(\pm R_R) \cdot (s + l)] \}$

4) Radial-Reaktionskraft  $R_B$  von Lager B:

$$R_B = \frac{M_{fA}}{l} \quad [\text{daN}]$$

1) reaction  $R_R$  produced by support R:

$$R_R = (1 / x_R) \cdot [G \cdot x + (\pm M_2)] \quad [\text{daN}]$$

2) bending moment  $M_{fA}$  through the cross-section of bearing A:

**B**  $M_{fA} = \sqrt{[G \cdot (y + s)]^2 + [R_R \cdot s]^2}$  [daN m]

3) radial reaction  $R_A$  produced by bearing A:

**B**  $R_A = \frac{1}{l} \sqrt{[G \cdot (y + s + l)]^2 + [R_R \cdot (s + l)]^2}$  [daN]

4) radial reaction  $R_B$  produced by bearing B:

$$R_B = \frac{M_{fA}}{l} \quad [\text{daN}]$$



## 22 - Zubehör und Sonderausführungen

### Langsamlaufende Wellen

Das Zubehör wird am Motor montiert geliefert. Die Standardlage für die normale langsamlauf. Welle ist mit Wellenende auf der Gegenseite der Rille. Für entgegengesetzte Montageposition, wenn möglich, (für einige Stirnradtriebmotoren MR 2l 40 ... 81 und MR 3l 40 ... 125 kann die langsamlauf. Welle nicht von Motorseite überhängen: rückfragen), nach der Bezeichnung «**Montage auf der Seite der Rille**» angeben.

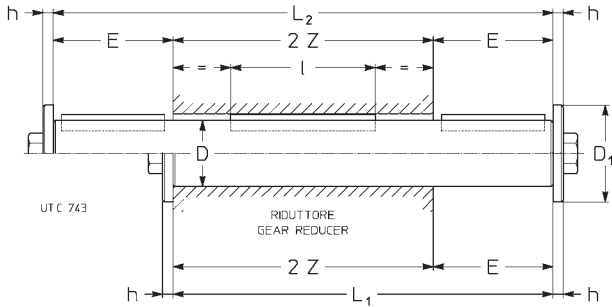

Das an das Getr. anschlagende Element oder Distanzbuchse muss einen Außendurchmesser von  $(1,25 \pm 1,4) \cdot D$  aufweisen; Toleranz der Bohrung D H7 ... K7.

The outer diameter of the part, or spacer abutting with the gear reducer must be  $(1,25 \pm 1,4) \cdot D$ ; D hole tolerance H7 ... K7.

- 1) **Nicht** genormter Wert; mit normaler langsamlaufender Welle,  $E = 97$ .
- 2) **Nicht** genormter Wert.
- 3) Für MR 3l erhöht Maß E um 1.

- 1) Value **not** to standard; with standard low speed shaft,  $E = 97$ .
- 2) Value **not** to standard.
- 3) For MR 3l the dimension E increases of 1.

Zusatz zur **Bestellbezeichnung**: **Normale** oder **beidseitig vorstehende langsamlaufende Welle**.

### Langsamlaufende Vollwelle (Größen 225, 280, 360)

Für den Betrieb bei den hohen im Katalog angegebenen Radialbelastungen sind die Getriebe Größen 225, 280, 360 mit langsamlaufender Vollwelle und verstärkten Lagern erhältlich. Die Abmessungen bleiben unverändert; es entfällt jedoch die Scheibe am Wellenende. Auch ohne überdimensionierte Lager (ungeänderte Radialbelastungen) auch für Größen 180, 200, 250, 320, 321 zur Verfügung.

Zusatz zur **Bestellbezeichnung**: **An der Gegenseite (1)** oder **an der Seite der Rille (2)** oder **beidseitig vorstehende Vollwelle**.

### Überdimensionierte langsamlaufende Hohlwelle

Getriebe- und Getriebemotorengrößen 40, 50, 64 und 100 können mit überdimensionierter langsamlaufender Hohlwelle ausgeführt werden; Abmessungen s. folgende Tabelle. Scheibe zur langsamlaufenden Hohlwelle ist nicht lieferbar.

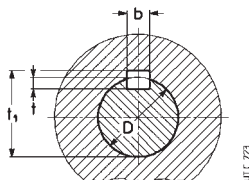

Zusatz zur **Bestellbezeichnung**: **Überdimensionierte langsamlaufende Hohlwelle**.

### Flansch

Sämtliche Getriebe und Getriebemotoren sind mit **B5-Flansch**, Durchgangslöchern und «Zentrierbohrung» erhältlich.

**B5-Flansch** muss auf die Gegenseite zur Rille des Getriebe montiert werden (Antriebsgegenseite, für Stirnradgetriebe, für deren Größen 40 ... 125 diese die einzige mögliche Position ist; für größere Größen, bitte rückfragen). Für Montageposition auf der Seite der Rille (nur bei Kegelstirnradgetr.) ist «**Montage auf der Seite der Rille**» anzugeben.

Auf Schrauben und Paarungsflächen empfehlen wir die Anwendung von Starkklebern Typ LOCTITE.

Bez. Maße  $H_1$  und  $Z$  s. Kap. 8, 10, 13 und 16.

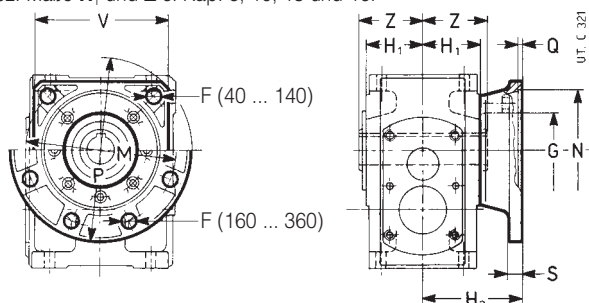

Zusatz zur **Bestellbezeichnung**: **B5-Flansch**.

## 22 - Accessories and non-standard desi-

### Low speed shafts

The accessory is supplied fitted onto the gear reducer. Standard mounting position is with shaft end on opposite side to groove. For reverse mounting, whenever possible (in particular cases of parallel shaft gearmotors MR 2l 40 ... 81 and MR 3l 40 ... 125 the low speed shaft cannot project from motor side; consult us), specify in designation «**groove side mounting**».

Getriebe- größe Gear reducer size	D Ø	E	D <sub>1</sub> Ø	h	L <sub>1</sub>	L <sub>2</sub>	l	Z	Schraube Bolt UNI 5737-88	Masse Mass kg	
										Normal Standard	Beid. vorsteh. Double ext.
<b>40</b>	19 h7	30	28	4	122	152	50	92	M 6 × 20	0,3	0,4
<b>50</b>	24 h7	36 <sup>3)</sup>	35	5	142	178	63	106	M 8 × 25	0,6	0,7
<b>63</b>	30 h7	58 <sup>3)</sup>	47	5	184	242	63	126	M 10 × 30	1	1,3
<b>64</b>	32 h7	58 <sup>3)</sup>	47	5	184	242	70	126	M 10 × 30	1,2	1,5
<b>80</b>	38 h7	58	47	5	208	266	90	150	M 10 × 30	1,9	2,4
<b>81</b>	40 h7	58	47	5	208	266	90	150	M 10 × 30	2,1	2,7
<b>100</b>	48 h7	82	57	6	262	344	110	180	M 12 × 40	3,7	4,9
<b>125</b>	60 h7	101 <sup>1)</sup>	82	8	317	422	140	220	M 16 × 45	7	9,4
<b>140</b>	70 j6	105	82	8	355	460	180	250	M 16 × 45	11	14
<b>160</b>	80 j6	130	102	10	402	532	200	272	M 20 × 60	18	24
<b>180</b>	90 j6	130	102	10	430	560	200	300	M 20 × 60	21	28
<b>200</b>	100 j6	165	135	12	499	664	250	334	M 24 × 60	36	46
<b>225</b>	110 j6	165	135	12	525	690	250	360	M 24 × 60	39	51
<b>250</b>	125 j6	200 <sup>2)</sup>	160	16	612	812	320	412	M 30 × 70	62	83
<b>280</b>	140 j6	200	160	16	644	844	320	444	M 30 × 70	82	106
<b>320, 321</b>	160 j6	240	205	20	748	988	400	508	M 36 × 90	125	165
<b>360</b>	180 k6	240	205	20	786	1026	400	546	M 36 × 90	166	216

Supplementary description when ordering by **designation**: **standard**, or **double extension low speed shaft**.

### Solid low speed shaft (sizes 225, 280, 360)

In order to permit the high radial loads given in the catalogue the gear reducers sizes 225, 280, 360 can be supplied with solid low speed shaft and strengthened bearings. Dimensions keep unchanged except the absence of washer on shaft end. Available, without strengthened bearings (radial loads unchanged), for sizes 180, 200, 250, 320, 321 too.

Supplementary description when ordering by **designation**: **solid low speed shaft opposite to groove side (1)** or **groove side (2)** or **double extension**.

### Oversized hollow low speed shaft

The gear reducers and gearmotors sizes 40, 50, 64 and 100 can be supplied with oversized hollow low speed shaft; dimensions are according to following table. The hollow low speed shaft washer can't be supplied.

Getriebe- größe Gear reducer size	D Ø H7	Passfeder Parallel key b x h x l*	Nutm Keyway		
			b	t	t <sub>1</sub>
<b>40</b>	20	6 × 6 × 50	6	4,5 <sup>1)</sup>	22,2 <sup>1)</sup>
<b>50</b>	25	8 × 7 × 63	8	4,5 <sup>1)</sup>	27,7 <sup>1)</sup>
<b>64</b>	35 <sup>2)</sup>	10 × 8 × 90	10	6,5 <sup>1)</sup>	36,8 <sup>1)</sup>
<b>100</b>	50	14 × 9 × 125	14	6,5 <sup>1)</sup>	52,8 <sup>1)</sup>

\* Empfohlene Länge.

1) **Nicht** genormte Werte.

2) Ohne Sicherungsringnut.

\* Recommended length.

1) **Not** unified values.

2) Without circlip groove.

Supplementary description when ordering by **designation**: **oversized hollow low speed shaft**.

### Flange

All gear reducers and gearmotors can be supplied with **B5** flange having clearance holes and spigot «recess». The **B5** flange is supplied fitted onto the gear reducer opposite side to groove (opposite to input side, for parallel shafts: for these ones, size 40 ... 125, it is the only possible mounting position; for higher sizes, consult us). For groove side mounting (for right angle shafts only), specify in designation «**groove side mounting**». Locking adhesives such as LOCTITE are recommended both around threads and on mating surfaces. For the value of dimensions  $H_1$  and  $Z$  see ch. 8, 10, 13 and 16.

Größe Size	F Ø	G Ø	H <sub>2</sub> h12	M Ø	N Ø H7	P Ø	Q	S	V □ kg	Masse Mass
<b>50</b>	9,5	70	80	130	110	160	4,5	12	122	1
<b>63, 64</b>	11,5	80	100	165	130	200	4,5	14	152	2
<b>80, 81</b>	14	110	112	215	180	250	5	16	196	3,2
<b>100</b>	14	130	132	265	230	300	5	18	248	5,5
<b>125</b>	18	180	154	300	250	350	6	20	290	8,5
<b>140</b>	18	230	165	350	300	400	6	22	350	13
<b>160</b>	18 <sup>5)</sup>	230	191	400	350	450	6	22	—	15
<b>180</b>	18 <sup>5)</sup>	250	191	400	350	450	6	22	—	20
<b>200</b>	18 <sup>5)</sup>	300	231	500	450	550	6	25	—	25
<b>225</b>	22 <sup>5)</sup>	350	231	500	450	550	6	25	—	31
<b>250, 280</b>	27 <sup>5)</sup>	450	280	600	550	660	7	30	—	50
<b>320 ... 360</b>	33 <sup>5)</sup>	550	345	740	680	800	7	37	—	80

Supplementary description when ordering by **designation**: **flange B5**.

**Viereckiger Flansch für Servomotoren**

MR 2l, 3l, Cl, ICl Getriebemotorengrößen 40 ... 125 können mit Motorbefestigungsflansch für Kupplung mit Servomotoren und, nur bei MR 2l und MR Cl, mit Stelling der Verkeilung mit Passfeder zwischen Getriebewelle und Motorwelle geliefert werden; bei MR 3l und MR ICl erlaubt das direkt auf dem Motorwellenende gekeilte Ritzel der ersten Stufe, Spiele und Stöße auf derselben Verkeilung zu vermeiden.

Da die Servomotoren keine Normabmessungen haben, alle in der Tabelle angegebenen Kupplungsabmessungen zur Auswahl nachprüfen; **d** Maß bestimmt die Motorgröße nach IEC bei Getriebemotorbezeichnung im Katalog (s. Kap. 3, 11, 14). Für andere Getriebemotorenabmessungen s. Kap. 13, 16.

Vor der Motordemontage den Stelling lockern.

Für die **Nachprüfungen** der Verkeilungsfestigkeit, des Motorbefestigungsflansches und der Motorlager in Abhängigkeit von Leistungen, Drehzahl, Masse und Länge desselben Motors, bitte **rückfragen**.

**Square flange for servomotors**

Gearmotors MR 2l, 3l, Cl, ICl sizes 40 ... 125 can be supplied with motor mounting flange when coupling with servomotors and, only for MR 2l and MR Cl, with hub clamp for fitting with key between gear reducer shaft and motor shaft; for MR 3l, MR ICl first reduction pinion directly keyed onto motor shaft end permits to avoid backlash and consequently shock on the same keying.

Considering that servomotors do not have any standardized dimensions, when selecting verify all coupling dimensions stated in the table; **d** dimension determines IEC standardized motor size in catalogue gearmotor designation (see ch. 3, 11, 14). For other gearmotor dimensions see ch. 13, 16.

In case of motor removing, first loosen the hub clamp.

For the **verifications** of keying, motor mounting flange and motor bearing resistance according to motor performances, speed, mass and length, **consult us**.

Bohrung zur Stellingsbefestigung  
Hole for hub clamp tightening

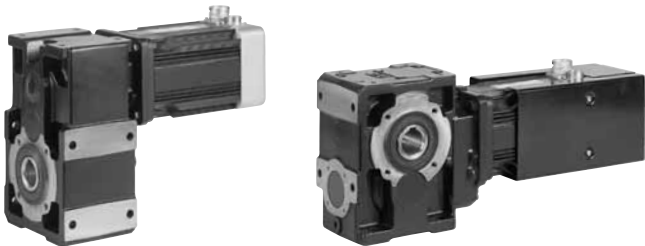
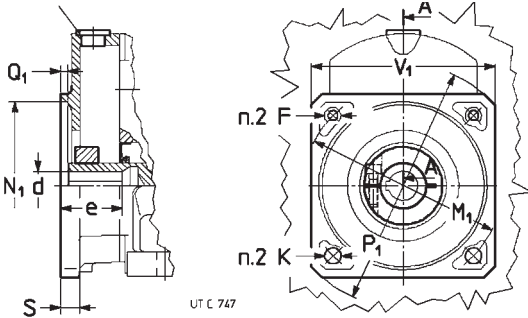

Beispiel vom Stirnradservogetriebemotor mit Brushless-synchronem Servomotor und Kegelstirnradservogetriebemotor mit Vektor- asynchronem Servomotor (SR-Kat.).  
Examples of parallel shaft servogearmotor with synchronous «brushless» servomotor and right angle shaft servogearmotor wuth «vector» servomotor (cat. SR).

Getriebegröße Gear reducer size	V <sub>1</sub> □	F	K ∅	M <sub>1</sub> ∅	N <sub>1</sub> ∅	P <sub>1</sub> ∅	Q <sub>1</sub>	S	d ∅	e		
<b>2l, 3l Cl, ICl</b>		1)			H7						2)	
<b>40</b>	—	90	—	7 <sup>4</sup>	100	80	120	4	9,5	11 <sup>4)</sup> 14	23 30	M 5
<b>50</b>	—	90	M 6	7	100	80	120	4	9,5	11 <sup>4)</sup> 14 19	23 30 40	M 5
		105	—	9,5 <sup>4</sup>	115	95	140	4	9,5	14	30	
		120	—	9,5 <sup>4</sup>	130	110	160	4,5	9,5	19	40	
<b>63, 64</b>	<b>40, 50</b>	90	M 6 <sup>4</sup>	—	100	80	120	4	9	11 <sup>5)</sup> 14 19	23 30 40	M 6 <sup>3)</sup>
		105	M 8	9,5	115	95	140	4	11	14 <sup>5)</sup> 19	30 40	
		120	—	9,5 <sup>4</sup>	130	110	160	4,5	11	14 <sup>4)</sup> 19 24	30 40 50	
<b>80, 81</b>	<b>63 ... 81</b>	105	M 8 <sup>4</sup>	—	115	95	140	4	10	14 19	30 40	M 6
		120	M 8	9,5	130	110	160	4,5	12	19 24	40 50	
		145	—	11,5 <sup>4</sup>	165	130	195	4,5	12	19 <sup>4)</sup> 24	40 50	
<b>100</b>	<b>100</b>	145	M 10	11,5	165	130	195	4,5	14	19 <sup>4)</sup> 24 28	40 50 60	M 6
<b>125</b>	<b>125</b>	145	M 10	—	165	130	195	4,5	16	24 <sup>4)</sup> 28 <sup>4)</sup>	50 60	—

- 1) Nutzlänge des Gewindes 2 · F.
- 2) Spanschraube des Stellings UNI 5931.  
Spanschlüssel muss min 110 mm lang sein.
- 3) M 5 für Größen 40, 50.
- 4) Nur für Zahnradgetriebe 3l.
- 5) Nur für Zahnradgetriebe ICl.
- 6) Nur für Größe ≥ 50.
- 1) Working length of thread 2 · F.
- 2) Locking screw for hub clamp UNI 5931.  
Tightening key must be at least 110 mm long.
- 3) M5 for sizes 40, 50.
- 4) For 3l train of gears only.
- 5) For ICl train of gears only.
- 6) For size ≥ 50 only.

Zusatz zur **Bestellbezeichnung: Viereckiger Flansch ... — ...** (V<sub>1</sub> Maß — d Maß angeben; z.B.: 145-24).

Supplementary description when ordering by **designation: square flange ... — ...** (state V<sub>1</sub> — d dimension; e.g.: 145-24).

**Rücklaufsperre**

Stirnradgetriebe Größen 63 ... 360 mit  $i_N ≥ 10$ , Kegelstirnradgetriebe mit  $i_N ≥ 12,5$  ( $i_N ≥ 10$  bei Größe 50;  $i_N ≥ 11,2$  bei Größen 160, 200, 250, 320, 321); Stirnrad- und Kegelstirnradgetriebemotoren mit  $n_2 ≤ 224 min^{-1}$  sind mit Rücklaufsperre erhältlich; Positionen und Bauarten s. unten. Bez. Maße **a**, **C**, **H**, **H<sub>1</sub>**, **H<sub>0</sub>** s. Kap. 8, 10, 13 und 16.

**Backstop device**

For sizes stated in the table, parallel shaft **gear reducers** with  $i_N ≥ 10$ , right angle shaft **gear reducers** with  $i_N ≥ 12,5$  ( $i_N ≥ 10$  for size 50;  $i_N ≥ 11,2$  for sizes 160, 200, 250, 320, 321), and parallel and right angle shaft **gearmotors** with  $n_2 ≤ 224 min^{-1}$  can be supplied with backstop device; designs and positions are shown in the drawings below. See ch. 8, 10, 13 and 16 for the value of dimensions **a**, **C**, **H**, **H<sub>1</sub>**, and **H<sub>0</sub>**.

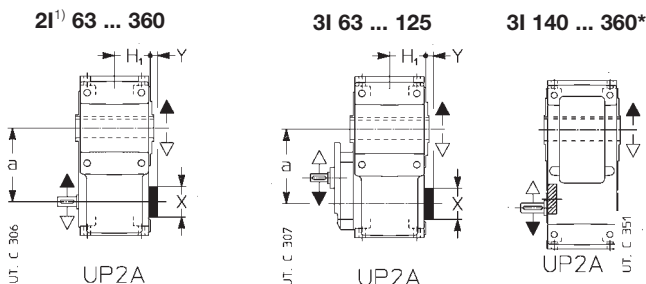

\* Die Rücklaufsperre steht aus Maß H<sub>1</sub> nicht vor. Auch für Bauart UP2D zur Verfügung.  
\* Backstop device doesn't project from dimension H<sub>1</sub>. Also available for UP2D design.

Getriebegröße Gear reducer size	<b>2l, 3l, 4l</b> <b>X</b> ∅	<b>Y</b>
<b>63, 64</b>	47	7
<b>80, 81</b>	52	7
<b>100</b>	62	7
<b>125, 140</b>	72	10
<b>160, 180</b>	90	10
<b>200, 225</b>	110	10
<b>250, 280</b>	130	7
<b>320 ... 360</b>	170	7

- 1) Auch MR 4l Größen 63 ... 125.
- 1) Also for MR 4l sizes 63 ... 125.

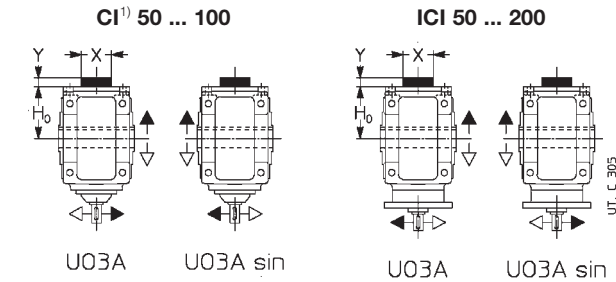

1) Auch MR C3I Größen 50 ... 125.  
1) Also for MR C3I sizes 50 ... 125.

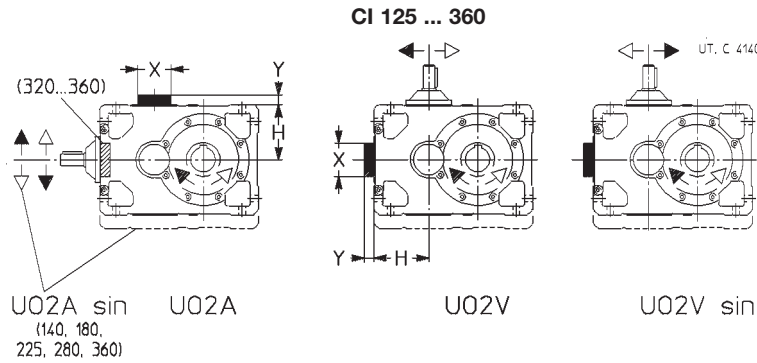
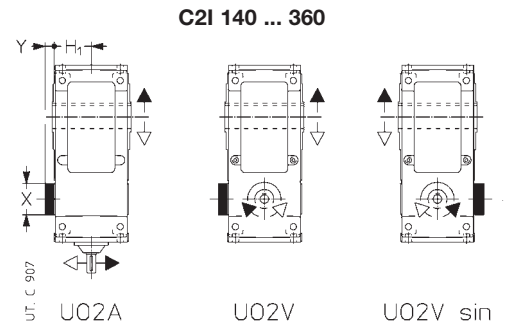

Getriebe- größe Gear reducer size	CI, ICI, C3I		C2I	
	X Ø	Y	X Ø	Y
50 ... 64	47	4	—	—
80, 81	52	4	—	—
100	62	4	—	—
125, 140	122	16	72	10
160, 180	155	21	90	10
200, 225	190	21	110	10
250, 280	238	26	130	7
320 ... 360	— <sup>2)</sup>	— <sup>2)</sup>	170	7

2) Rücklaufsperrung ist zwischen den Lagern der schnelllaufenden Welle eingebaut.  
2) Backstop device is fitted between high speed shaft bearings.

**Belastbarkeit der Rücklaufsperrung**

Nennmoment  $M_{N2}$  [daN m] der Rücklaufsperrung, sofern es kleiner ist als  $M_{N2}$  des Getriebes (Kap. 7, 9, 11, 14).  
Maximal zulässige Überbelastung  $1,7 \cdot M_{N2}$ .

Zusatz zur **Bestellbezeichnung**: Rücklaufsperrung, **Freidrehung lt. weißem oder schwarzem Pfeil**.

Getriebe- größe Gear reducer size	Zahnradgetriebe ( $i_h$ ) - Train of gears ( $i_h$ ) $M_{N2}$ [daN m]		
	3I (28) C2I (20)	2I (10) 3I (31,5) C2I (22,4)	3I (35,5) C2I (25)
140	280	315	355
180	560	630	710
225	1 120	1 250	1 400
280	2 120	2 360	2 650
321, 360	4 250	4 750	5 300

**Backstop device load capacity**

Nominal torque  $M_{N2}$  [daN m] of backstop device when lower than  $M_{N2}$  of gear reducer (see ch. 7, 9, 11, 14).  
Maximum permissible overload  $1,7 \cdot M_{N2}$ .

Supplementary description when ordering by **designation: backstop device, white or black arrow free-rotation**.

**Aufsteckbefestigungen**

Technische Erklärungen s. Kap. 21.  
Bez. Maße **A, A<sub>1</sub>, B** s. Kap. 8, 10, 13 und 16.

**Shaft-mounting arrangements**

See technical explanations at ch. 21.  
For dimensions **A, A<sub>1</sub>, B** see ch. 8, 10, 13 and 16.

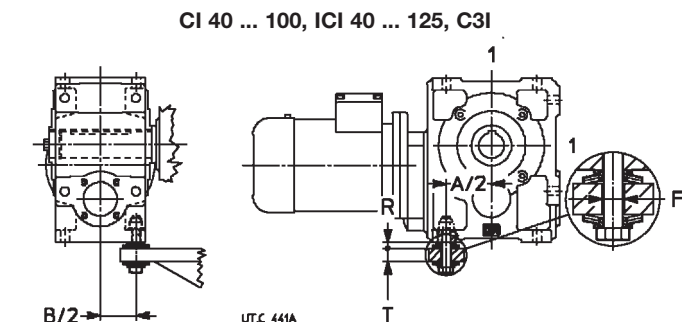
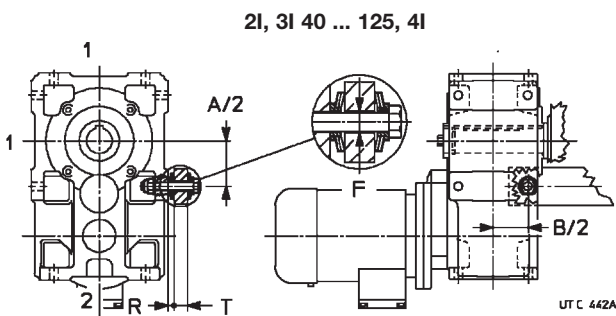

Bei Zahnradgetr. CI, ICI, C3I ist dieses System auf Seiten **1 vorzuziehen**; bei Zahnradgetrieben 2I, 3I, 4I kann es auf Seite **2 nicht** befestigt werden.  
Zusatz zur **Bestellbezeichnung**: **Reaktionsmutterschraube mit Tellerfedern**.

Getriebe- größe Gear reducer size	Schraube Bolt UNI 5737-88	Tellerfeder Disc spring DIN 2093	T	F Ø	R 1)	$M_2 \leq$ 2) daN m
40	M 6 × 40	A 18 n. 2	8 ÷ 10	8	4,9	6,3
50	M 8 × 55	A 25 n. 2	10 ÷ 14	11	6,5	14
63, 64	M 12 × 70*	A 35,5 n. 2	14 ÷ 17	20	8,8	22,4
80, 81	M 12 × 90	A 35,5 n. 3	18 ÷ 25	20	10,8	40
100	M 16 × 110	A 50 n. 2	25 ÷ 32	20	13,1	63
125	M 16 × 110	A 50 n. 2	25 ÷ 32	20	13,1	100

1) Theoretischer Wert; Toleranz 0 ÷ -1.  
2) Für größere  $M_2$ , 2 Reaktionsmutter-schrauben oder das System mit Bügel (s. folgende Seite) anwenden.  
\* Geänderte Schraube.

1) Theoretical value; tolerance 0 ÷ -1.  
2) For higher  $M_2$  values, use 2 reaction bolts or the arrangement with bracket (see following page).  
\* Modified bolt.

For train of gears CI, ICI, C3I it is **better** to apply this arrangement on the sides **1**; it **cannot** be applied on side **2** for train of gears 2I, 3I, 4I.  
Supplementary description when ordering by **designation: reaction bolt using disc springs**.

21, 31 40 ... 125, 41

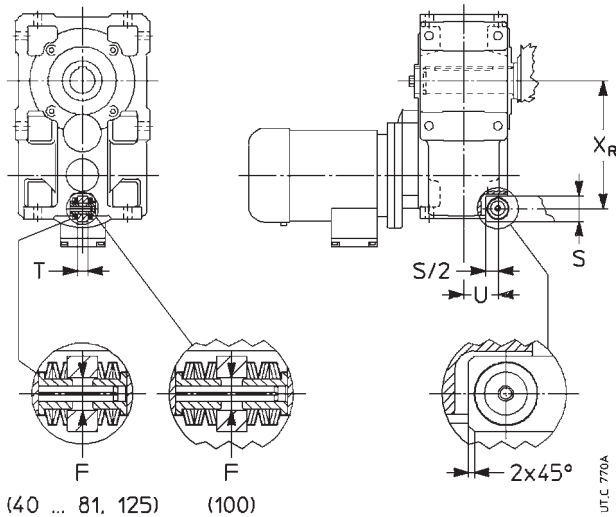

Getriebe- größe Gear reducer size	Tellerfeder Disc spring DIN 2093	F Ø	T h11	S	x <sub>R</sub>	U	M <sub>2</sub> ≤ daN m
40	A 18 n. 3	10	10	22	105,5	32,5	—
50	A 25 n. 3	13	12	30	130	37,5	—
63	A 25 n. 3	13	15	35	163	50	—
64	A 25 n. 3	13	15	35	165	50	35 <sup>2)</sup>
80, 81	A 35,5 n. 3	19	20	40	198,5	54	—
100	A 35,5 n. 6	19	25	50 <sup>1)</sup>	246 <sup>3)</sup>	66	—
125	A 50 n. 3	26	30	60	306 <sup>3)</sup>	82	260 <sup>2)</sup>

- 1) S/2 = 22,5 mm.
- 2) Für Bauform B3 und B8.
- 3) Für das lange Modell gilt Maß x<sub>R</sub>: 351 (Gr. 100), 439 (Gr. 125).

Zusatz zur **Bestellbezeichnung**: Satz mit Tellerfedern.

Supplementary description when ordering by **designation**: kit using reaction disc springs.

CI 63 ... 100, ICI 63 ... 200, C3I 63 ... 125

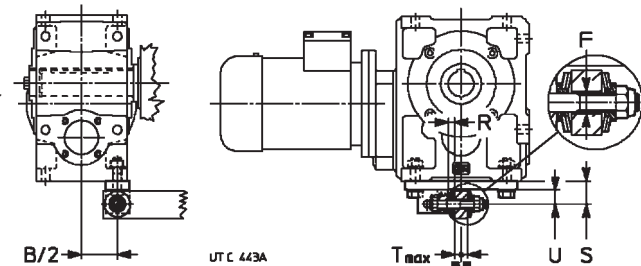

Getriebe- größe Gear reducer size	Schraube Bolt UNI 5737-88	Tellerfeder Disc spring DIN 2093	T	F Ø	S	U	R 1)
63, 64	M 12 × 70*	A 35,5 n. 1	14 ÷ 17	20	38	23	6,8
80, 81	M 12 × 90	A 35,5 n. 2	18 ÷ 25	20	38	23	8,8
100	M 16 × 110	A 50 n. 2	25 ÷ 32	20	50	30	13,1
125, 140	M 16 × 110	A 50 n. 2	25 ÷ 32	20	50	30	13,1
160, 180	M 20 × 130	A 63 n. 3	23 ÷ 38	24	65	40	17,9
200	M 24 × 160	A 80 n. 2	29 ÷ 48	30	80	48	20,7

- 1) Theoretischer Wert: Toleranz 0 ÷ -1.
- \* Geänderte Schraube.

Dieses System kann bei Bedarf (Raumbedarf, geringe Beanspruchung o.a.) auf der **kurzen** Seite befestigt werden, die von der langsamlaufenden Welle aller Getriebe-Größen 63 ... 200 weiter entfernt ist.

This arrangement can be applied, if need be (overall dimension, less stress or other reasons) on the **short** farthest side from low speed shaft in all gear reducers sizes 63 ... 200.

Zusatz zur **Bestellbezeichnung**: Reaktionsmutterschraube mit Tellerfedern und Bügel.

Supplementary description when ordering by **designation**: reaction bolt using disc springs and bracket.

CI 63 ... 100, ICI 63 ... 200, C3I 63 ... 125

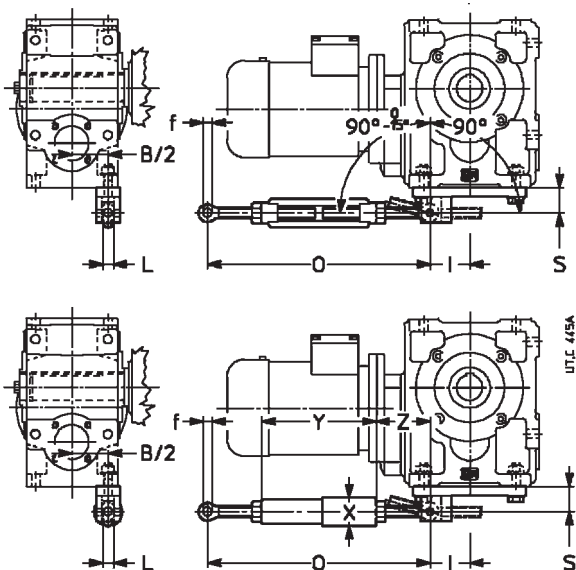

Getriebe- größe Gear reducer size	f Ø	O	S	L	X Ø	Y	Z ≈	I
63, 64	12	280 ÷ 350	38	14	—	—	—	50
80, 81	12	280 ÷ 350	38	14	—	—	—	56
100	16	410 ÷ 510	50	17	52	242	84	74
125, 140	16	410 ÷ 510	50	17	52	242	84	74
160, 180	22	580 ÷ 680	65	24	64	285	147	92
200	28	580 ÷ 680	80	30	88	305	137	113

Dieses System kann bei Bedarf (Raumbedarf, geringe Beanspruchung o.a.) auf der **kurzen** Seite befestigt werden, die von der langsamlaufenden Welle aller Getriebe-Größen 63 ... 200 weiter entfernt ist.

This arrangement can be applied, if need be (overall dimension, less stress or other reasons) on the **short** farthest side from low speed shaft in all gear reducers sizes 63 ... 200.

Zusatz zur **Bestellbezeichnung**: Steife oder elastische Drehmomentstütze mit Bügel.

Supplementary description when ordering by **designation**: rigid or flexible torque arm using bracket.

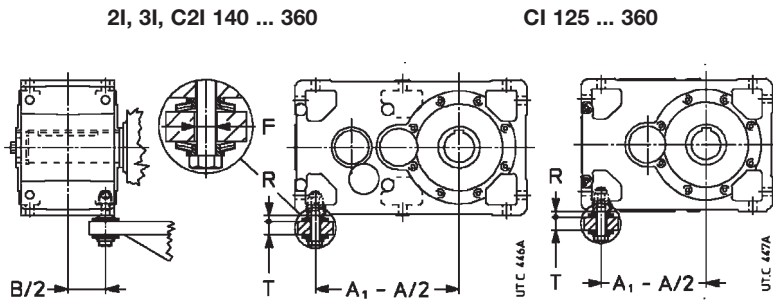

Getriebe- größe Gear reducer size	Schraube Bolt UNI 5737-88	Tellerfeder Disc spring DIN 2093	T	F Ø	R 1)
<b>125, 140</b>	M 16 × 110	A 50 n. 2	25 ÷ 32	20	13,1
<b>160, 180</b>	M 20 × 130	A 63 n. 3	25 ÷ 38	24	17,9
<b>200, 225</b>	M 24 × 160	A 80 n. 2	29 ÷ 48	30	20,7
<b>250, 280</b>	M 30 × 200	A 100 n. 2	37 ÷ 60	36	26,2
<b>320 ... 360</b>	M 36 × 260	A 100 n. 3	45 ÷ 75	42	32,2

1) Theoretischer Wert: Toleranz 0 ÷ -1.1) Theoretical value: tolerance 0 ÷ -

Zusatz zur **Bestellbezeichnung: Reaktionsmutterschraube mit Tellerfedern.**

Supplementary description when ordering by **designation: reaction bolt using disc springs.**

**Abgestufte langsamlaufende Hohlwelle**

**Stepped hollow low speed shaft**

Getriebe und Getriebemotoren Größen 64 ... 360 sind auch mit abgestufter langsamlaufender Hohlwelle samt Passfedernut erhältlich. Diese Ausführung **erleichtert** die Montage bzw. Demontage und **verstärkt wesentlich** die Steifheit und Biege- sowie Verdrehfestigkeit des Maschinenzapfens.

Gear reducers and gearmotors sizes 64 ... 360 can be also supplied with stepped hollow low speed shaft always with keyway; this design **facilitates** installation and removal and **affords a notable increase** in rigidity and resistance to bending and torsional stresses at the shaft end of the driven machine.

Die Bohrung mit Ø D<sub>2</sub> ist immer **gegenseitig zur Rille.**

Hole with Ø D<sub>2</sub> is always **opposite to groove side.**

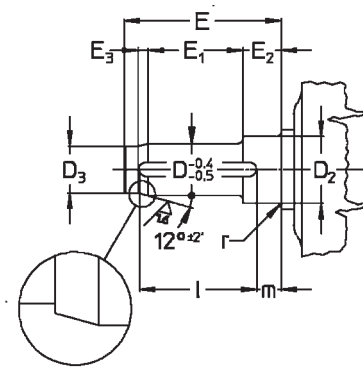
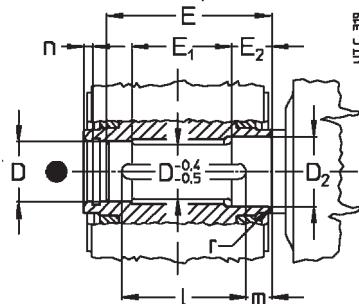

Getriebe- größe Gear reducer size	D Ø	D <sub>2</sub> Ø	D <sub>3</sub> Ø H7/h6	E	E <sub>1</sub>	E <sub>2</sub>	E <sub>3</sub>	l	m	n	r
<b>64</b>	H7/j6, k6		27	110	63	28	10	70	28	6	1,5
<b>80</b>	32	35	32	134	75	35	12	90	30	6	1,5
<b>81</b>	38	40	34	134	72	38	12	90	30	6	1,5
<b>100</b>	40	42	41	162	92	41	14	110	35	7	2
<b>125</b>	48	52	52	201	118	47	16	140	40	7	2
<b>140</b>	60	65	62	228	135	52	16	180	35	8	2
<b>160</b>	70	75	70	250	147	57	21	200	36	8	3
<b>180</b>	90	100	80	274	162	63	21	200	50	9	3
<b>200</b>	100	110	88	308	188	66	25	250	42	10	3
<b>225</b>	110	120	98	331	195	75	25	250	55	10	3,5
<b>250</b>	H7/h6, j6		110	380	228	84	32	320	40	11	4
<b>280</b>	125	135	125	410	238	94	32	320	60	12	4
<b>320, 321</b>	140	150	140	471	276	107	43	400	45	13	5
<b>360</b>	160	170	160	506	293	116	43	400	72	14	5

● Position der Bezugsrille (s. Kap. 20).

● Position of the reference groove (see ch. 20).

Die linke Zeichnung zeigt den Maschinenzapfen für Verkeilung mit Passfeder.

The left drawing shows a shaft end of driven machine for coupling with a key.

Die rechte Zeichnung zeigt den Maschinenzapfen für Verkeilung mit Passfeder und Spannbuchse (s. Kap. 21).

The right drawing shows a shaft end of driven machine for coupling with a key and locking bush (see ch. 21).

**Wichtig:** Der Durchmesser des gegen das Getriebe anschlagnenden Maschinenzapfens muss mindestens (1,18 ÷ 1,25) · D betragen.

**Important:** the shoulder diameter of the shaft end of the driven machine abutting with the gear reducer must be at least (1,18 ÷ 1,25) · D.

Zusatz zur **Bestellbezeichnung: Abgestufte langsamlaufende Hohlwelle.**

Supplementary description when ordering by **designation: stepped hollow low speed shaft.**

**Langsamlaufende Hohlwelle mit Spannsatz**

**Größen 40 ... 125**

Sämtliche Getriebe und Getriebemotoren Größen 40 ... 125 können mit langsamlaufender Hohlwelle mit Spannsatz (s. Abb. a) – **immer an der Gegenseite der Rille** bzw. an der Gegenseite des Motors für Stirnradgetriebemotoren – und mit festem Schutzdeckel an der Seite der Rille geliefert werden (außer Antriebsseite der Stirnradgetriebe u. – getriebemotoren Gr. 40, 50 und MR 3l 63).

Diese Ausführung **verstärkt wesentlich** die Steifheit der Verkeilung, **vermindert** die Verformungen des Maschinenzapfens (hohes **D** Maß), erlaubt Verbindungen auch mit Durchgangswelle (s. Abb. b) und wenn sie zwischen Getriebe und Maschine liegt, **vermeidet** sie eventuell die Notwendigkeit von Unfallschutzmaßnahmen auf der Einheit.

Der Maschinenzapfen, auf den die Getriebehohlwelle aufgezogen wird, soll nach den in Tabelle angegebenen Abmessungen sein.

**Wichtig:** Der Durchmesser des gegen das Getriebe anschlagenden Maschinenzapfens muss mindestens  $(1,12 \div 1,18) \cdot D$  betragen.

1) Nur für Kegelstirnradgetriebe oder langes Modell.

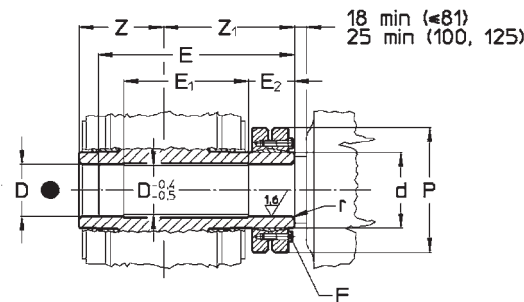

a) Langsamlaufende Hohlwelle mit Spannsatz und Maschinenzapfen  
a) Hollow low speed shaft with shrink disc and machine shaft end

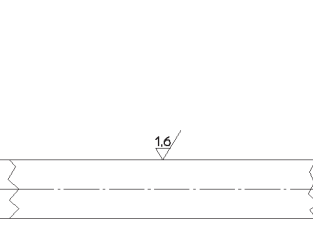

b) Durchgangsmaschinenwelle  
b) Machine passing through shaft

Getriebe- größe Gear reducer size	D Ø H7/j6, h6 <sup>1)</sup>	E	E <sub>1</sub>	E <sub>2</sub>	F	M daN m 2)	d Ø	P Ø	r	Z	Z <sub>1</sub>
					UNI 5737-88 cl. 10.9						
<b>40</b>	20	99,5	65	25	M 5 n. 6	0,4	24	50	0,5	46	69
<b>50</b>	25	116,5	77	30	M 5 n. 7	0,4	30	60	0,5	53	79
<b>63</b>	30	135,5	86	34	M 6 n. 5	1,2	38	72	0,5	63	91
<b>64</b>	35	140	86	36	M 6 n. 7	1,2	44	80	1,5	63	93
<b>80, 81</b>	40	166	103	39,5	M 6 n. 8	1,2	50	90	1,5	75	107
<b>100</b>	50	197	122	46,5	M 8 n. 6	3	62	110	2,5	90	125
<b>125</b>	65	239	148	55	M 8 n. 7	3	80	145	2,5	110	148

1) Toleranz g6 möglich für Wellenende an der Gegenseite des Spannsatzes.

2) Spanndrehmoment.

● Position der Bezugsrille (s. Kap. 20).

1) Tolerance g6 also possible for shaft end opposite to shrink disc.

2) Tightening torque.

● Position of the reference groove (see ch. 20).

**Größen 140 ... 360: Maschinenseite**

Alle Getriebe und Getriebemotoren Größen 140 ... 360 können mit **abgestufter** langsamlaufender Hohlwelle mit Spannsatz an der Maschinenseite – bzw. an der **Gegenseite der Rille**, d.h. an der Gegenseite des Motors bei Stirnradgetriebemotoren – und festen Schutzdeckel an der Seite der Rille geliefert werden.

Diese Ausführung **erleichtert** die Montage und Demontage, **verstärkt wesentlich** die Steifheit der Verkeilung, **vermindert** die Verformungen des Maschinenzapfens, vermeidet etwaige Interferenzproblemen zwischen Motorflansch und Spannsatz (Stirnradgetriebe) und **vermeidet** eventuell die Notwendigkeit von Unfallschutzmaßnahmen auf der Einheit. Da die Verformung der Verkeilung größer ist ( $d - D_2 < d - D$ ) und die Reibung auf einem größeren Durchmesser ausgeführt wird ( $D_2 > D$ ), erhöht das max Drehmoment um  $18 \div 25\%$  in Bezug auf die Lösung mit Spannsatz an der Gegenseite der Maschine.

Für eine zusätzliche Axialbefestigung und um die Montage und Demontage erleichtern zu können (s. Kap. 21), ist es möglich, die Scheibe der langsamlaufenden Hohlwelle mit Sicherungsring und Schraube für die Axialbefestigung (auf Anfrage) anzuwenden.

Für den Maschinenzapfen, auf welchen die abgestufte langsamlaufende Getriebehohlwelle gekeilt werden muss, ist es möglich, sowohl die Lösung mit «langem» Zapfen als auch mit «kurzem» Zapfen anzuwenden: Abmessungen s. Tabelle (für die anderen Abmessungen s. Kap. 20, 21).

Im ersten Fall (Abb. c), wo der «lange» Zapfen als Führung wirkt, wird die Montage erleichtert. Die etwaige Anwendung von einer Spannbuchse mit Scheibe zur langsamlaufenden Hohlwelle (Abb. d) vermindert wesentlich die Berührungsanrostung, erleichtert wesentlich die Demontage und hilft teilweise – gleichzeitig – bei der Übertragung des Drehmoments.

Im zweiten Fall (Abb. e) begrenzt die reduzierte Axialabmessung des «kurzen» Maschinenzapfens wesentlich den Raumbedarf zur Montage und Demontage.

In beiden Fällen ändern die Steifheit und Biege- sowie Verdrehfestigkeit Maschinenzapfens nicht, da die einzige Fläche, durch welche die Übertragung des Drehmoments stattfindet, diejenige auf dem Durchmesser  $D_2$  ist.

**Sizes 140 ... 360: side to machine**

All gear reducers and gearmotors sizes 140 ... 360 can be supplied with **stepped** hollow low speed shaft with shrink disc **side to machine** – that is **opposite side to groove**, i.e. opposite side to motor for parallel shaft gearmotors – and not rotating protection cap on groove side.

This design **facilitates** installation and removal and affords a **notable increase** in rigidity of keying and **reduces** the deformations of machine shaft end, avoids possible problems of interference between shrink disc and motor flange and may **avoid** the use of safety guards on the unit itself. Moreover, since deformability of keying area is greater ( $d - D_2 < d - D$ ) and friction area acts on a greater diameter ( $D_2 > D$ ), maximum transmissible torque increases by  $18 \div 25\%$  compared to the solution with shrink disc on opposite side to machine.

For a further axial fastening and in order to facilitate the assembling and disassembling operations (see ch. 21), it is possible to make use of hollow low speed shaft washer with circlip and bolt for axial fastening (on request).

For the shaft end of driven machine on which gear reducer stepped hollow low speed shaft must be keyed, it is possible to adopt both «long» and «short» shaft end of driven machine: dimensions as per table (for the other dimensions see ch. 20, 21).

In the first case (fig. c), where the «long» shaft end of driven machine acts as a guide, mounting operations are facilitated. The eventual adoption of the locking bush with hollow low speed shaft washer (fig. d), reducing the fretting corrosion at the very least, especially facilitates the disassembling operations by giving at the same time a help in the torque transmission.

In the second case (fig. e), the reduced axial dimension of the «short» shaft end of driven machine, limits the mounting and removing overall dimensions at the very least.

In both cases the rigidity and the resistance to bending and torsional stresses at the shaft and of driven machine do not change, since the only surface through which torque transmission occurs is the  $D_2$  one.

**Wichtig:** der Durchmesser des gegen das Getriebe anschlagenden Maschinenzapfens muss mindestens  $(1,18 \div 1,25) \cdot D$  betragen.

**Important:** the shoulder diameter of the shaft end of driven machine abutting with the gear reducer must be at least  $(1,18 \div 1,25) \cdot D$ .

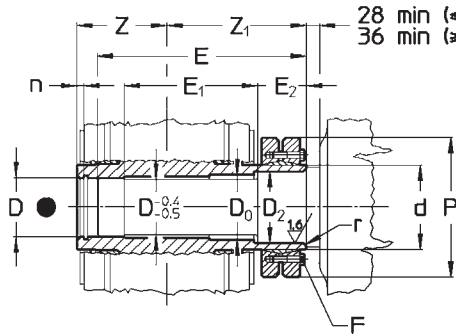

c) Abgestufte langsamlaufende Hohlwelle mit Spannsatz und «langem» Maschinenzapfen  
 c) Stepped hollow low speed shaft with locking assembly and «long» machine shaft end

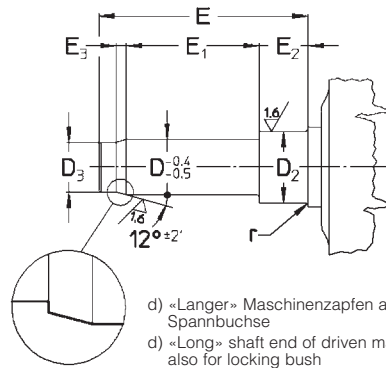

d) «Langer» Maschinenzapfen auch für Spannbuchse  
 d) «Long» shaft end of driven machine also for locking bush

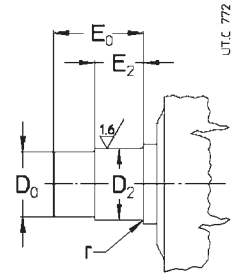

e) «Kurzer» Maschinenzapfen  
 e) «Short» shaft end of driven machine

Getriebe- größe Gear reducer size	D Ø	D <sub>2</sub> Ø	D <sub>3</sub> Ø	D <sub>0</sub> Ø	E	E <sub>0</sub>	E <sub>1</sub>	E <sub>2</sub>	E <sub>3</sub>	F	M daN m	d Ø	P Ø	n	r	Z	Z <sub>1</sub>	M <sub>2</sub> daN m
<b>140</b>	70	75	62	72	273	99	180	52	16	M 8 n. 10	3	90	155	8	2	125	170	970
<b>160</b>	80	85	70	82	307	114	199	62	21	M 10 n. 9	6	105	185	8	3	136	193	1 450
<b>180</b>	90	100	80	95	335	124	221	65	21	M 10 n. 12	6	120	215	9	3	150	211	2 250
<b>200</b>	100	110	88	105	377	135	251	72	25	M 12 n. 10	10	130	230	10	3	167	236	3 250
<b>225</b>	110	120	98	115	404	150	265	78	25	M 12 n. 12	10	140	265	10	3,5	180	253	4 540
<b>250</b>	125	135	110	130	461	165	307	86	32	M 16 n. 8	25	160	290	11	4	206	287	6 290
<b>280</b>	140	150	125	145	506	185	324	104	32	M 16 n. 10	25	180	330	12	4	222	318	8 560
<b>320, 321</b>	160	170	140	165	567	203	375	104	43	M 16 n. 12	25	200	350	13	5	254	350	12 190
<b>360</b>	180	195	160	190	621	231	400	124	43	M 16 n. 15	25	230	370	14	5	273	388	17 200

1) Spanndrehmoment.  
 2) Max Werte bez. des Spannsatzes.  
 ● Position der Bezugsrille (s. Kap. 20).

1) Tightening torque.  
 2) Max values relevant to shrink disc.  
 ● Position of the reference groove (see ch. 20).

**Größen 140 ... 360: Gegenseite der Maschine**

Alle Getriebe und Gebläsemaschinen Größen 140 ... 360 können mit **abgestufter** langsamlaufender Hohlwelle mit Spannsatz an der **Gegenseite der Maschine**, d.h. an der **Seite der Rille** (s. Abb. f). Im Vergleich mit der Ausführung auf der Seite der Maschine verbessert diese Ausführung die Zugänglichkeit zum Spannsatz, aber ist teurer, mit einer kleineren Drehsteifigkeit und mit Grenzen in der maximalen zulässigen Motorgröße für MR 2I ... UP2 ...; der Spannsatz übersetzt ein kleineres Drehmoment und normalerweise benötigt Unfallschutzmaßnahmen (vom Kunden gepflegt, auf Anfrage s. «Sonstiges»).

**Wichtig:** der Durchmesser des gegen das Getriebe anschlagenden Maschinenzapfens muss mindestens  $(1,18 \div 1,25) \cdot D$ .

**Sizes 140 ... 360: side opposite to machine**

All gear reducers and gearmotors sizes 140 ... 360 can be supplied with **stepped** hollow low speed shaft and shrink disc **opposite side to machine**, i.e. **groove side** (see. fig. f).

This design, compared with the machine side design, improves the accessibility to the shrink disc but it is more expensive, with lower torsional stiffness and with limits in the max admissible motor size for MR 2I ... UP2 ...; the shrink disc transmits a lower torque and, normally, requires a personal safety-guards (on Buyer's responsibility; on request, see «Miscellaneous»).

**Important:** the shoulder diameter of the shaft end of the driven machine abutting with the gear reducer must be at least  $(1,18 \div 1,28) \cdot D$ .

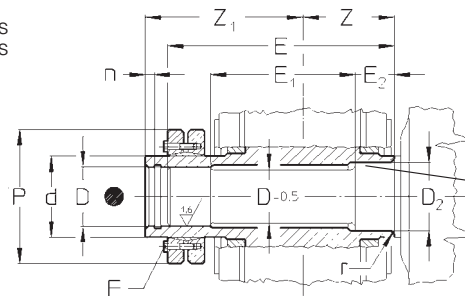

Zone der langsamlauf. Hohlwelle gegen Kontaktrost geschützt.  
 Hollow low speed shaft zone protected against fretting corrosion.

f) Abgestufte langsamlaufende Hohlwelle mit Spannsatz und Maschinenzapfen.

f) Stepped hollow low speed shaft with locking assembly and machine shaft end.

Getriebe- größe Gear reducer size	MR 2I ... UP2 ... max Motorgröße max motor size (S./page 86)	D Ø	D <sub>2</sub> Ø	E	E <sub>1</sub>	E <sub>2</sub>	F	M daN m	n	d Ø	P Ø	r	Z	Z <sub>1</sub>	M <sub>2</sub> daN m
<b>140</b>	132, 160 B5R	70	75	294,5	192,5	52	M 8 n. 10	3	8	90	155	2	125	191,5	800
<b>160</b>	180	80	85	329	208	57	M 10 n. 9	6	8	105	185	3	136	215	1 200
<b>180</b>	180, 200 B5R	90	100	363	228	63	M 10 n. 12	6	9	120	215	3	150	239	1 800
<b>200</b>	225	100	110	402	260	66	M 12 n. 10	10	10	130	230	3	167	261	2 600
<b>225</b>	225, 250 B5R	110	120	428	277	75	M 12 n. 12	10	10	140	265	3,5	180	277	3 660
<b>250</b>	280	125	135	493	318	84	M 16 n. 8	25	11	160	290	4	206	319	5 160
<b>280</b>	280, 315S B5R	140	150	543	337	94	M 16 n. 10	25	12	180	330	4	222	355	7 150
<b>320, 321</b>	315	160	170	607	388	107	M 16 n. 12	25	13	200	350	5	254	390	10 200
<b>360</b>	315	180	195	668	414	116	M 16 n. 15	25	14	230	370	5	273	435	14 300

1) Spanndrehmoment.  
 2) Max Werte bezüglich des Spannsatzes.  
 ● Position der Bezugsrille (s. Kap. 20).

1) Tightening torque.  
 2) Max values relevant to shrink disc.  
 ● Position of the reference groove (see ch. 20).

Zusatz zur Bestellbezeichnung: **Langsamlaufende Hohlwelle mit Spannsatz**; für Größe ≥140, bestätigen Sie, ob es sich um **Maschinenseite** oder **Gegenseite der Maschine** handelt.

Supplementary description when ordering by **designation: hollow low speed shaft with shrink disc**; for sizes ≥140, states if **side to machine** or **opposite side to machine**.

**Zusätzliche Bohrungen des Gehäuses**

Getriebe und Getriebemotoren 2l, 3l 140 ... 360 sind mit Gewindebohrungen auf der seitigen Gehäusefläche an der Gegenseite der Rille erhältlich, um eventuelle zusätzliche Befestigung zum B14-Flansch o.a. auszuführen. Für entsprechende Maße s. Kap. 20 «Getriebeantriebsseite».

Zusatz **zur Bestellbezeichnung: Zusätzliche Bohrungen des Gehäuses.**

**Zusätzliche Kühlung mit Lüfter**

Stirnradgetriebe der in Tabelle angegebenen Größe und Zahnradgetriebe sind mit **einem** oder **zwei** Lüftern erhältlich. Maß **e**, **e<sub>1</sub>** und **c**, **c<sub>1</sub>** s. Kap. 8.

Für die Getriebe R I 140 und R I 180 ist diese Ausführung nicht möglich: bei Bedarf bitte rückfragen.

Auch Getriebemotoren MR 2l 160 ... 360 und MR 3l 200 ... 360 **UP ... D** sind mit **einem** Lüfter erhältlich.

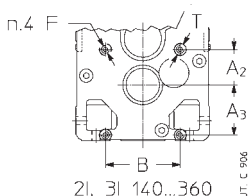

**Additional casing holes**

Gear reducers and gearmotors 2l, 3l 140 ... 360 can be supplied with casing tapped holes on opposite side to groove for shaft mounting, in addition to B14 flange or else. For dimensions see ch. 20 «Gear reducers input side».

Supplementary description when ordering by **designation: additional casing holes.**

**Fan cooling**

Parallel shaft gear reducers of size and train of gears indicated in the table can be supplied fitted with **one** or **two** fans. See ch. 8 for dimensions **e**, **e<sub>1</sub>**, and **c**, **c<sub>1</sub>**.

The design is not possible for R I 140 and R I 180 gear reducers contact us if necessary.

Gearmotors MR 2l 160 ... 360 and MR 3l 200 ... 360 **UP...D** can be supplied fitted with **one** fan as well.

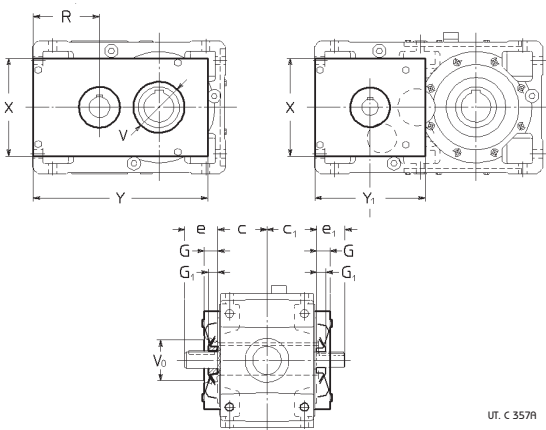

Getriebegröße Gear reducer size		G	G <sub>1</sub>	R	V <sub>0</sub> ∅	V ∅	X	Y	Y <sub>1</sub>
I <sup>5)</sup>	2I <sup>5)</sup>	1)			4)				
125	140	34	25	148	90	90	212	379	247
160	160, 180	38	25	178	110	115	264	469	297
200	200 <sup>2)</sup> , 225 <sup>2)</sup>	44	32	223	130	140	326	585	357
225		44	32	223	140	160	326	610	—
250	250 <sup>2)</sup> , 280 <sup>2)</sup>	52	40 <sup>3)</sup>	278	160	175	426	740	447
280		52	40	278	175	200	426	770	—
320, 321	320 <sup>2)</sup> ... 360 <sup>2)</sup>	63	50 <sup>3)</sup>	353	200	220	554	951	557
360		63	50	353	220	260	554	991	—

- 1) Die Schrauben stehen aus Maß **G** 6 mm vor.
- 2) Gültig auch für Zahnradgetriebe **3l**.
- 3) Bei R 3l Maß G<sub>1</sub> = 32 (280), 40 (320 ... 360).
- 4) Nur bei **zweitem** Lüfter Pos. **2** oder, auf Anfrage, in anderen Fällen.
- 5) Mit B5-Flansch auf der Lüfterseite, Ausführung nicht möglich. Bei Bedarf bitte rückfragen.
- 1) Bolts projecting 6 mm from dimension **G**.
- 2) It is also valid for train of gears **3l**.
- 3) For R 3l dimension G<sub>1</sub> = 32 (280), 40 (320 ... 360).
- 4) Only for **second** fan in pos. **2** or, at request, in other cases.
- 5) Design not possible with B5 flange on fan side; if required, consult us.

Kegelstirnradgetriebe der in Tabelle angegebenen Größe und Zahnradgetriebe sind mit **einem** Lüfter erhältlich. Maße **e** und **c** s. Kap. 10.

Auch Getriebemotoren MR CI, C2l 160 ... 360 ... **D ...**, ... **H ...**, ... **R ...** sind mit **einem** Lüfter erhältlich.

Right angle shaft gear reducers of size and train of gears indicated in the table can be supplied fitted with **one** fan. See ch. 10 for dimensions **e** and **c**.

Gearmotors MR CI, C2l 160 ... 360 ... **D ...**, ... **H ...**, ... **R ...** can be supplied fitted with **one** fan as well.

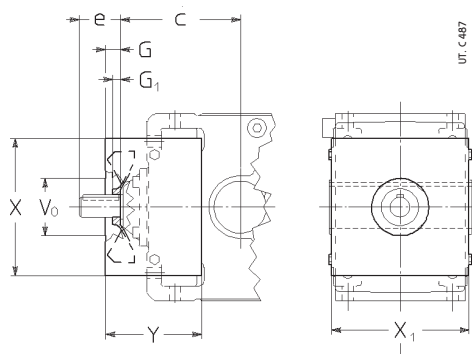

Getriebegröße Gear reducer size		G	G <sub>1</sub>	V <sub>0</sub> ∅	X	X <sub>1</sub> <sup>1)</sup>	Y
R CI	125 ≤ 8, 140 ≤ 9	25	15	90	212	212	140
R CI	160 ≤ 8, 180 ≤ 9	34	20	110	264	264	209
R CI	160 ≥ 9 ≤ 16, 180 ≥ 10 ≤ 16; MR CI 160 ≥ 6,3 ≤ 14, 180 ≥ 10 ≤ 16	29	15	110	264	264	184
R C2l	160 ≤ 31,5, 180 ≤ 31,5	25	15	110	264	264	184
MR C2l	160 ≤ 63, 180 ≤ 63	36	15	110	264	264	184
R CI	200 ≤ 8, 225 ≤ 9	41	20	150	326	326	255
R CI	200 ≥ 9 ≤ 16, 225 ≥ 10 ≤ 16; MR CI 200 ≥ 6,3 ≤ 14, 225 ≥ 10 ≤ 16	41	20	130	326	326	232
R C2l	200 ≤ 31,5, 225 ≤ 31,5	34	20	130	326	326	232
MR C2l	200 ≤ 63, 225 ≤ 63	51	15	130	326	326	232
R CI	250 ≤ 10, 280 ≤ 11,2	47	25	175	426	404	317
R CI	250 ≥ 11,2 ≤ 16, 280 ≥ 12,5 ≤ 16; MR CI 250 ≥ 10 ≤ 14, 280 ≥ 10 ≤ 16	46	25	150	426	404	293
R CI	250 ≥ 18, 280 ≥ 18; MR CI 250 ≥ 16, 280 ≥ 18	46	20	150	426	404	293
R C2l	250 ≤ 31,5, 280 ≤ 31,5	43	20	150	426	404	293
R C2l	280 ≥ 35,5 ≤ 63; MR C2l 250 ≤ 63, 280 ≤ 63	41	20	150	426	404	268
R CI	320 ... 360	57	32	220	554	500	392
R C2l	320 ... 360 ≤ 31,5	55	32	220	554	500	365
R C2l	320 ... 360 ≥ 35,5 ≤ 63; MR C2l 320 ... 360 ≤ 63	46	25	185	554	500	333

1) Die Schrauben stehen aus Maß **X**, 6 mm je Seite vor.

1) For both sides, bolts projecting 6 mm from dimension **X**<sub>1</sub>.





## 22 - Zubehör und Sonderausführungen

In der Bauart mit beidseitig vorstehender schnelllaufender Welle ist der **Zugang** zu beiden Wellenenden auch mit eingebautem Lüfter **möglich**. Der Kunde ist für die Zurüstung der etwaigen Unfall-schutzvorrichtung zuständig (98/37/EWG).

Bauarten und Position s. unten.

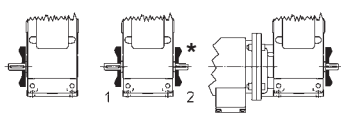

- \* Lüfterposition nicht möglich bei R 2l 140 und Zahnradgetriebe C2l.
- \*\* Lüfterposition niemals möglich.

Die Kühllufttemperatur darf den Wert der Umgebungstemperatur nicht übersteigen.

Zusatz zur **Bestellbezeichnung**: **Zusätzliche Kühlung mit Lüfter**; bei Bauart mit beidseitig vorstehender schnelllaufender Welle Position **1** oder **2** oder – nur für Stirnradgetriebe – Pos. **1** und **2** angeben.

Auch zusätzliche Kühlung mit Kühleinheit mit Wärmeaustauscher (s. «Sonstiges») möglich; bei Bedarf bitte rückfragen.

### Zusätzliche Kühlung mit Kühlschlange

Die Getriebe und Getriebemotoren Größen 125 ... 360, inkl. Extruderlager, können mit Kühlschlange für Wasserkühlung ausgeliefert werden.

Eigenschaften des Kühlwassers:

- niedrige Härte;
- max Temperatur 20 °C;
- Durchfluss 10 ÷ 20 dm<sup>3</sup>/min;
- Druck 0,2 ÷ 0,4 MPa (2 ÷ 4 bar).

Für die Verbindung ist es ausreichend, eine glatte metallische Leitung s. Aussendurchmesser **d** laut Tabelle anzuwenden.

Auch Ausführung mit direkt auf Getriebekappe montierter Kühlschlange zur Verfügung, um die Wartung zu erleichtern: reduzierte Wärmefaktorwerte **f<sub>t</sub>**, bitte rückfragen.

Auf Anfrage ist ein **thermostatisches Ventil** zur Verfügung, das automatisch und ohne Zusatzversorgung den Wasserdurchfluss ermöglicht, wenn das Getriebeöl die gewählte Temperatur erreicht; Der Ventildrüse ist mit Ölsumpf ausgersüet. Die Montage und die Eichung, die von 50 ÷ 90 °C eingestellt werden kann, sind vom Kunden ausgeführt.

Für Umgebungstemperatur kleiner als 0 °C bitte rückfragen.

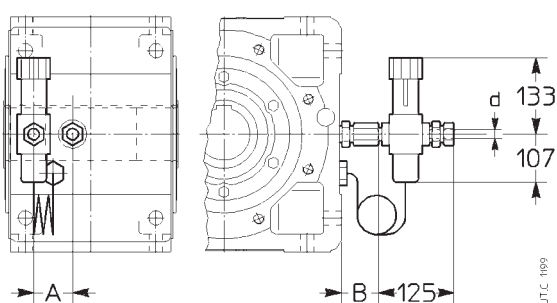

Zusatz zur **Bestellbezeichnung**: **Getriebe u/o Extruderlager mit Zusatzkühlung mit Kühlschlange** oder **Zusatzkühlung mit Kühlschlange und thermostatisches Ventil**.

### Lagerschmierpumpe

Getriebe und Getriebemotoren Größen 100 ... 360 sind je nach Zahnradgetriebe, Bauart, Übersetzung, Bauform, Antriebsdrehzahl und Betrieb mit Kolbenpumpe (Nockensteuerung von langsamlaufender Welle) oder alternativ hierzu – nur bei Zahnradgetriebe 2l – mit Schmiervorrichtung (Größe 100 ... 280) schnelllaufender Welle zur Lagerschmierung erhältlich.

Bei  $n_1 \leq 1\,400 \text{ min}^{-1}$  sind die Bedarfsfälle der Lagerschmierpumpe oder Schmiervorrichtung schnelllaufender Welle mit  $\text{⊕}$  (Kap. 8, 10, 13, 16) gekennzeichnet.

Bei  $n_1 \geq 1\,500 \text{ min}^{-1}$  **bitte rückfragen**.

Zusatz zur **Bestellbezeichnung**: **Lagerschmierpumpe** oder **Schmiervorrichtung schnelllaufender Welle**.

## 22 - Accessories and non-standard designs

With double extension high speed shaft design both extensions are **accessible** even with fan fitted: personnel safety-guards are the Buyer's responsibility (98/37/CEE).

Designs and position are as shown below.

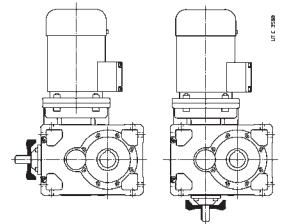

- \* Fan position not possible for R 2l 140 and train of gears C2l.
- \*\* Fan position never possible.

Temperature of cooling air must not exceed ambient temperature.

Supplementary description when ordering by **designation**: **fan cooling**; in design with double extension high speed shaft state if pos. **1** or **2** or – only for parallel shaft gear reducers – **1** and **2**.

Also available independent cooling unit with heat exchanger (see «Miscellaneous»); if required, consult us.

### Water cooling by coil

Gear reducers and gearmotors sizes 125 ... 360, prospective extruder support included, can be supplied with coil for water cooling.

Cooling water specifications:

- be not too hard;
- max temperature 20 °C;
- capacity 10 ÷ 20 dm<sup>3</sup>/min;
- pressure 0,2 ÷ 0,4 MPa (2 ÷ 4 bar).

For the connection it is sufficient to use a smooth metallic tube having a **d** external diameter as per table.

Also available coil mounted directly onto gear reducer cover to ease maintenance: reduced thermal factor **f<sub>t</sub>** values, consult us.

On request **thermostatic valve** which, automatically and without auxiliary supply need, permits water circulation when gear reducer oil reaches the set temperature; the valve sensor is equipped with immersion bulb. Mounting and setting, adjustable within 50 ÷ 90 °C, are Buyer's responsibility.

For ambient temperature lower than 0 °C consult us.

Getriebe- größe Gear reducer size	A <sup>1)</sup> ≈	B <sup>1)</sup> ≈	d ∅
125 ... 180	40	40	12
200 ... 280	50	40	12
320 ... 360	60	45	16

1) Richtwerte gültig für Bauform B3 und Bauart U ... A. Für andere Bauformen u/o Bauarten, bitte rückfragen.

1) Values valid for B3 mounting position and U ... A design only. For other mounting positions and/or designs: consult us.

Supplementary description when ordering by **designation**: **gear reducer** and/or **extruder support** with **water cooling by coil** or **water cooling by coil and thermostatic valve**.

### Bearings lubrication pump

Gear reducers and gearmotors sizes 100 ... 360 – according to train of gears, design, transmission ratio, mounting position, input speed and duty – can be supplied fitted with piston pump (driven by a cam from the low speed shaft) or alternatively – only for train of gears 2l (sizes 100 ... 280) – with high speed shaft lubrication device for bearings lubrication.

For  $n_1 \leq 1\,400 \text{ min}^{-1}$  the cases where bearings lubrication pump or high speed shaft lubrication device may be required are marked with  $\text{⊕}$  (ch. 8, 10, 13, 16).

For  $n_1 \geq 1\,500 \text{ min}^{-1}$  **consult us**.

Supplementary description when ordering by **designation**: **bearings lubrication pump** or **high speed shaft lubrication device**.

### Bimetallischer Thermostat

Sämtliche Getriebe und Getriebemotoren Größe  $\geq 100$  sind mit Bimetall-Thermostat zur Überwachung der max Öltemperatur lieferbar.

Eigenschaften des Thermostats:

- NC-Kontakt mit max Strom 10 A - 240 V DS (5 A - 24 V Gs);
- G  $1/2$ " - Anschluss;
- Kabeldichtung Pg 09;
- Schutzart IP 65;
- Ansprechtemperatur  $90\text{ °C} \pm 5\text{ °C}$  (auf Anfrage sind andere Ansprechtemperaturen möglich);
- Differentialtemperatur  $15\text{ °C}$ ;

Der Einbau in eine Gewindebohrung (Position je nach Bauform und Befestigung zu bestimmen: bitte rückfragen) und ins Ölbad ist kundenseitig vorzunehmen.

Zusatz zur **Bestellbezeichnung: Bimetallischer Thermostat.**

### Scheibe zur langsamlaufenden Hohlwelle

Alle Getriebe und Getriebemotoren sind mit Scheibe, Sicherungsring (außer Größen 40...63), Schraubefür Axialbefestigung und Schutzdeckel (außer Antriebsseite der Stirnradgetriebe und -getriebemotoren Gr. 40, 50 und Getriebemotoren 3l 63), Kap. 21.

Zusatz zur **Bestellbezeichnung: Scheibe zur langsamlaufenden Hohlwelle.**

### Scheibe zur langsamlaufenden Hohlwelle mit Spannringen oder Spannbuchse

Alle Getriebe und Getriebemotoren (außer MR 3l 40 ... 63) sind mit Scheibe, Sicherungsring (außer Größen 40 ... 63), Spannringen (Größen 40 ... 63) oder Spannbuchse (Größen 64 ... 360), Schraube zur Axialbefestigung und Schutzdeckel (außer Antriebsseite der Stirnradgetriebe und -getriebemotoren Gr. 40, 50), Kap. 21.

Zusatz zur **Bestellbezeichnung: Scheibe zur langsamlaufenden Hohlwelle mit Spannringen oder Spannbuchse.**

### Schutzdeckel der langsamlaufenden Hohlwelle

Getriebe und Getriebemotoren Größen 40 ... 160 sind mit dem einzigen Schutzdeckel für die von der langsamlaufenden Hohlwelle nicht angewendete Zone erhältlich (Kap. 21). Montage nicht möglich auf der Antriebsseite für Stirnradgetriebe und -getriebemotoren Größe 40, 50 und Getriebemotoren 3l 63.

Mit langsamlaufender Standardwelle nicht anwendbar.

Mit Doppeldichtung (Größen 64 ... 160) kann der Schutzdeckel nicht ausgeliefert werden sondern eine auf den B14-Flansch zu befestigende Haube.

Zusatz zur **Bestellbezeichnung: Schutzdeckel der langsamlaufenden Hohlwelle** mit Deckel oder Haube.

### Ausführung für Rührwerke, Belüfter, Ventilatoren

Diese Ausführung ist speziell für den Einsatz in Belüftern, Rührwerken und Ventilatoren mit hohen Biegemomenten (größenordnungsmäßig  $\geq 0,4 \cdot M_2$ ) entwickelt worden.



Neben dem steifen und präzisen **Monoblockgehäuse**, der «symmetrischen» **Universalbefestigung**, der **patentierten** Verkeilung für Motorgrößen 200 ... 315, die die Montage und Demontage vereinfacht und die Berührungsanrostung verhindert und den Kegelrollenlagern, sind die grundlegenden Eigenschaften dieser **zuverlässigen, kompakten** und **wirtschaftlichen** Ausführung:

### Bi-metal type thermostat

Gear reducers and gearmotors sizes  $\geq 100$  can be supplied with bi-metal type thermostat for the control of the maximum admissible oil temperature.

Thermostat specifications:

- NC contact with maximum alternate current 10 A - 240V d.c. (5 A - 24V d.c.);
- G  $1/2$ " thread connection;
- Pg 09 cable gland;
- IP65 protection;
- Setting temperature  $90\text{ °C} \pm 5\text{ °C}$  (other setting temperatures are possible, on request);
- Differential temperature  $15\text{ °C}$ ;

Mounting into a threaded plug (position to be defined according to mounting position and mounting arrangement: consult us) and oil bath lubrication is Buyer's responsibility.

Non-standard design code for the **designation: bi-metal type thermostat.**

### Hollow low speed shaft washer

All gear reducers and gearmotors can be supplied with washer, circlip (excluding sizes 40 ... 63), bolt for axial fastening and protection cap (excluding input side of parallel and right angle shaft gear reducers and gearmotors, size 40, 50 and gearmotors 3l 63), see ch. 21.

Supplementary description when ordering by **designation: hollow low speed shaft washer.**

### Hollow low speed shaft washer with locking rings or bush

All gear reducers and gearmotors (excluding MR 3l 40 ... 63) can be supplied with washer, circlip (excluding sizes 40 ... 63), locking rings (sizes 40 ... 63) or locking bush (sizes 64 ... 360), bolt for axial fastening and protection cap (excluding input side of parallel and right angle shaft gear reducers and gearmotors, size 40, 50), see ch. 21.

Supplementary description when ordering by **designation: hollow low speed shaft washer with locking rings or bush.**

### Hollow low speed shaft protection

Gear reducers and gearmotors, sizes 40 ... 160, can be supplied with only the protection cap for the area not utilized by the hollow low speed shaft (ch. 21). Mounting not possible on input face for parallel shaft gear reducers and gearmotors size 40, 50 and gearmotors 3l 63.

It cannot be used with standard low speed shaft.

With double seal (sizes 64 ... 160) it is not possible to supply protection cap but a cover to be fixed to B14 flange.

Supplementary description when ordering by **designation: hollow low speed shaft protection** with cap or cover.

### Design for agitators, aerators, fans

This design has been specifically studied for aerators, agitators and fan drives, where there is a very high bending moment ( $\geq 0,4 \cdot M_2$  approx.).

In addition to the rigid and precise **monobloc** casing, «symmetrical» **universal** mounting, **patented** keying system for motor sizes 200 ... 315 which offers easier assembly and disassembly and avoid fretting corrosion, taper roller bearings, the fundamental characteristics of this **compact, economic** and **reliable** design are:

## 22 - Zubehör und Sonderausführungen

- verlängerte Nabe, um radiale und axiale Belastbarkeit zu erhöhen (Kegelrollenlager) und um Belastungsstößen zu vermindern;
- reichliche Bemessung des langsamlaufenden Wellenendes;
- Doppeldichtung der langsamlauf. Welle mit verchromter Lauffläche;
- Wellendichtringe geschützt durch Labyrinthischeibe, mit Fliehkraftwirkung bei Ventilatoren und Spritzschutz bei den Belüftern und Rührwerken, mit Fettkammer zwischen den Wellendichtringen;
- **Ölschmierung** des Lagers an der Seite des langsamlaufenden Wellenendes: Ölbad Schmierung bei untenliegendem Lager, mittels Pumpe (Mehrpreis) bei obenliegendem Lager; vollständige Entleerung durch zusätzliche Inox-Ölablassschraube. All dies versichert eine **maximale Zuverlässigkeit** (Verzahnung - Lager) des Betriebs und **minimale Wartung**;
- 1 K-Sonderlackierung: Rostschutzgrundierung mit Zinkphosphaten plus Synthetiklack blau RAL 5010 DIN 1843.

Auf Anfrage:

- Motorkalotte (serienmäßiger Schutz IP 55) mit Tropfwasserschutz;
- 2-K Sonderlackierung;
- Ölstand-Öltemperaturfernanzeige mit Schwellensignal (Gr.  $\geq 160$ );
- zusätzliche Bohrungen des Gehäuses auf dem langsamlaufenden Wellenende.

Die Kombinationen mit der Ziffer **2** sind zu bevorzugen (Drehrichtung - Axialbelastungsrichtung), da sie den größeren Wert der zwei maximalen Axialbelastungen  $F_{a2}$  vom Kap. 19 aufnehmen.

Bei Zahnradgetrieben ICI und C3I; für CI und C2I sind die Ausführungen ...sin nicht möglich.

- Position der Bezugsrille (s. Kap. 20); sie dient zur Identifikation auf Katalog der Getriebeausführung und -bauform.

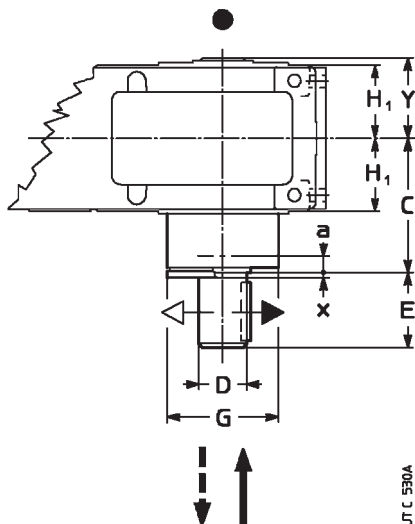

## 22 - Accessories and non-standard designs

- extended bearing housing to improve radial and axial load ratings (taper roller bearings) and to reduce overhangs;
- generously dimensioned low speed shaft end diameter;
- double seals on the low speed shaft with chromium plated raceway;
- space between double seals packed with grease and top hat arrangement which acts as water splash guard for aerators and as slinger for fans;
- **oil** lubricated bearing on low speed shaft end side: oil-bath for lower position, pump lubrication for upper position (price addition); additional stainless steel drain plug to facilitate complete oil drainage. All this ensures **total reliability** (gear pairs and bearings) during running and **minimum maintenance**;
- special single compound paint: antirust zinc primer plus blue RAL 5010 DIN 1843 synthetic paint.

Options:

- drip proof cover for motor (standard IP 55);
- special dual compound paint;
- remote oil level and/or oil temperature indicator with threshold signal (sizes  $\geq 160$ );
- additional tapped holes on casing on low speed shaft end side.

Combinations **2** (direction of rotation - axial load direction) are to be preferred since they permit to withstand the highest of the two  $F_{a2}$  axial loads (see ch. 19).

ICI and C3I trains of gears not possible; for CI and C2I the ...sin designs are not possible.

- Position of the reference groove (see ch. 20): useful to identify on catalogue the gear reducer design and mounting position.

Getriebe- größe Gear reducer size	a	C	D Ø m6	E	G Ø	x ≈	Y	Axialbelastung $F_{a2}$ Axial load $F_{a2}$			
								←	↑	↓	→
<b>125</b>	55	220	70	105	140	3	108	1	2	2	1
<b>140</b>	62	235	70	105	159	3	122	1	2	2	1
<b>160</b>	68	270	90	130	183	4	133	2	1	1	2
<b>180</b>	72	275	90	130	226	4	148	2	1	1	2
<b>200</b>	76	327	110	165	248	4	164	1	2	2	1
<b>225</b>	76	340	110	165	248	4	177	1	2	2	1
<b>250</b>	97	402	140	200	310	5	203	2	1	1	2
<b>280</b>	97	418	140	200	310	5	218	2	1	1	2
<b>320, 321</b>	110	505	180	240	388	6	250	1	2	2	1
<b>360</b>	110	523	180	240	388	6	268	1	2	2	1

Für Maß **H**, s. Kap. 8, 10, 13 und 16.  
1) Position des Lagerdruckpunkts.  
2) Dicke der Schutzscheibe.

For dimension **H**, see ch. 8, 10, 13 and 16.  
1) Position of the pressure center of the bearing.  
2) Thickness of protection disk.

Zusatz zur **Bestellbezeichnung: Ausführung für Rührwerke.**

**WICHTIG.** Für die Auswahl der Getriebe- oder Getriebemotorgröße und die Überprüfung der Radial- und Axialbelastungen (und daher der Notwendigkeit dieser Ausführung) **sind Rückfragen unbedingt erforderlich: Ein spezielles Kalkulationsprogramm** ermöglicht eine schnelle und zuverlässige Antwort.

Supplementary description when ordering by **designation: design for agitators.**

**IMPORTANT.** For selection of the gear reducer or gearmotor size and verification of radial and axial loads (and hence for the need of this design) **we always must be consulted: a detailed programme of calculation** enables us to give a quick and reliable answer.

## Ausführung für Extruder

Die **Standard**-Stirnrad- und Kegelstirnradgetriebe und -getriebemotoren Größen 125 ... 360 sind mit einem **zusätzlichen Außenlager auf Extruderseite** erhältlich, um die Verbindung mit **Einschneckenextruder** zu ermöglichen. Zwei Lagerungstypen: für normale Belastungen **N** (ökonomischer, für Standardanwendungen) und hohe Belastungen **H** (für schwere Betriebe, auch bei den Ausführungen **HA, HB, HC**, für Ausziehung der Schnecke auf Extruder-Gegenseite).

Das reichlich dimensionierte schrägstellbare Drucklager zwischen Getriebe und Extruder ist geeignet, **die hohen Axialkräfte**, wie sie beim Betrieb eines Extruders auftreten, aufzunehmen. **Die Position der Extruderlagerung auf Maschinenseite** reduziert die Belastungen und Verformungen des Getriebegehäuses mit Vorteilen für Eingriffspräzision und Zuverlässigkeit.

Die **Ausführung** für die **Extraktion der Schnecke auf Extruder-Gegenseite** bietet die maximale Anwendungsflexibilität mit **drei Kupplungslösungen** für Extruderschneckenendstück/Getriebehohlwelle (die Extraktion auf Extruderseite mit geeigneten Abmessungen der Extruderschnecke ist auch möglich): **HA** mit Passfeder, **HB** mit Keilprofil auf Extruderseite und **HC** mit Keilprofil auf Extruder-Gegenseite.

Diese Baulösung erlaubt, ein **Standardgetriebe** anzuwenden, mit folgenden Vorteilen: Robustheit, Präzision (dank der Steifheit des durch reichlich bemessene Kegel- und Zylinderringlager gelagerten langsamlaufenden Wellenendes), getestete Leistungen, Zuverlässigkeit und Service. Möglich auch mit «Getriebe nach ATEX»: für Auswahl, Nachprüfung und Bezeichnung, s. unten.

### Personalisierung

Das Produkt ermöglicht außer **Standard**- Konfigurationen (Ausführung N, H) auch verschiedene Kundenpersonalisierungen (auch bez. Zubehörs auf Anfrage) wie z.B.:

- **Kupplungsabmessungen** der Extruderlagerung zu der angetriebenen Maschine, bez. der Abmessungen P und N (s. Abm. N, H) «**auf Kundenwunsch**» ausgeführt (je nach Bohrungsanzahl, -position und -abmessung: rückfragen);
- **Anpassungsflansch** (auf Anfrage) zwischen Extruderlagerung und Extruder liegend zur höchsten Anwendungsflexibilität: rückfragen;
- **Unabhängige Kühleinheit** (auf Anfrage) mit Öl/Wasser Wärmeaustauscher – für die Kühlung des Getriebes und der Extruderlagerung – der mit Schutzvorrichtungen, Bemessungsinstrumente und Alarmanzeiger;

Für Leistungen, Abmessungen, Betriebssystem und Zubehör auf Anfrage, s. gesonderte Unterlagen: Rückfragen.

### Bestimmung der Getriebe- oder Getriebemotorgröße

Die Hinweise vom Kap. 6a und 6b befolgen: beachten, daß es außer der allgemeinen Angaben (Leistungen  $P_1$  und  $P_2$ , Drehzahlen  $n_1$  und  $n_2$ , Betriebsbedingungen: Belastungsart, Dauer, Schalthäufigkeit, Betrieb, Umgebungstemperatur, Bauform, Antriebsverbindungsart, usw.) notwendig ist, die **bestimmten** Angaben der Anwendung zu kennen:

- Art, Dichte und Durchflußmenge des fließgepressten Materials;
- Eigenschaften der Schraube des Extruders: Außendurchmesser, Durchmesser und Länge des Endstücks, Schraubenrichtung, statische und dynamische Axialkraft.

Im Allgemeinen ist es empfohlen, einen Betriebsfaktor  $f_s \geq 1,6$  zu haben, der für leichte Überbelastungen, Betriebsdauer  $\geq 50\ 000$  h, Zuverlässigkeitsgrad 1,12 geeignet ist.

### Nachprüfungen

Für die Nachprüfungen des Falls die Hinweise vom Kap. 6a und 6b befolgen; bei der Analyse der Wärmeleistung des Getriebes müssen die Werte von  $P_{tN}$  (s. Kap. 4) mit 0,85 multipliziert werden (Luftgeschwindigkeit  $< 0,63$  m/s: Rückfragen).

Außerdem muss man die Wärmeleistung des Extruderlagers nachprüfen und beachten, dass die Wärmekennzahl auf Tabellen (für Ausführung HA ... HC s. Tabelle Ausführung H) wie folgt ist:

$$\text{Wärmekennzahl} \geq \frac{n_2 \cdot F_{ad} \cdot (D + d)}{4\ 000\ 000}$$

wobei:  
 $n_2$  [min<sup>-1</sup>] Drehzahl der langsamlaufenden Welle  
 $D, d$  [mm] die Außen- und Innendurchmesser des Drucklagers sind (s. folgende Tab. 1 und 2)  
 $F_{ad}$  axial dynamisch [daN]

Wenn die Überprüfung unzureichende Resultate ergibt, ist es notwendig, die Fremdkühlung vorzusehen: mit **Lüfter** (nur bei Getriebe), mit **Kühlschlange**, mit **unabhängiger Kühleinheit** mit Öl/Wasser-Wärmeaustauscher).

Bei der Lieferung wird das Produkt immer mit **Überprüfungsrechnungen des Lebens des schrägstellbaren Drucklagers** nach ISO 281 in Bezug auf die Belastungsbedingungen (axial-dynamische  $F, n_2$ ) der Anwendung des Kunden ausgeliefert.

## Design for extruders

**Standard** manufactured parallel and right angle shaft gear reducers and gearmotors sizes 125 ... 360 can be supplied with **an auxiliary external support on extruder side** in order to have **single screw extruder** coupling; 2 types of support: normal **N** (more economical, for standard applications) and high **H** loads (for heavy duties, in the designs **HA, HB, HC**, for screw extraction on opposite side to extruder).

The adjustable and generously dimensioned thrust bearing, interposed between gear reducer and extruder, makes this design suitable to withstand **heavy axial loads** generated during the extruder running. The **position of extruder support on machine side** allows indeed to limit the stress and deformation of gear reducer casing for a greater meshing precision and reliability.

The **design for screw extraction on the opposite side to extruder** offers the maximum application flexibility with three coupling solutions between extruder screw spigot/gear reducer hollow shaft (the extraction on extruder side with proper extruder screw dimensions is possible): **HA** with key, **HB** with spline profile on extruder side and **HC** with spline profile on opposite side to extruder.

The particular construction solution adopted allows the use of the **standard gear reducer** assuring: strength, precision (thanks to rigidity of low speed shaft supported by generously dimensioned taper roller bearings), tested performance, reliability and service.

Also available in combination with «Gear reducer design ATEX»: for selection, verification and designation see further.

### Customizations

The product was not only foreseen for **standard** designs (design N, H) but also for customizations (accessories on request, as well), such as:

- extruder support **coupling dimensions** of driven machine are «**customized**» (consult us for number, position and dimension of the holes) to P and N dimensions (see design N, H);
- **adaptation flange** (on request) interposed between extruder support and extruder, for the maximum application versatility: consult us;
- **independent cooling unit** (on request) with oil/water heat exchanger – for the simultaneous cooling of gear reducer and extruder support – which can be customized on request with protections, measuring instruments and alarm signals;

for powers, dimensions, functional scheme and accessories on request, see specific documentation: consult us.

### Determination of gear reducer or gearmotor size

Follow the instructions of ch. 6a and 6b, keeping in mind that in addition to the general data (powers  $P_1$  and  $P_2$ , speeds  $n_1$  and  $n_2$ , running conditions: nature of load, duration, frequency of starting, duty cycle, ambient temperature, mounting position, input connection type, etc.) it is necessary to have **specific** application data:

- nature, density and capacity of the extruded material;
- extruder screw specifications: external diameter, spigot diameter and length, hand of spiral, static and dynamic axial force.

In general, it is recommended to use a service factor  $f_s \geq 1,6$ , valid for moderate overloads, running duration  $\geq 50\ 000$  h, reliability level 1,12.

### Verifications

Follow the instructions at ch. 6a, 6b, keeping in mind that in the analysis of the thermal power of the gear reducer, the values of  $P_{tN}$  (nominal thermal power, see ch. 4) must be multiplied by 0,85 (for air velocity  $< 0,63$  m/s, please consult us).

It is necessary to evaluate the thermal power of the extruder bearing housing and to verify that the thermal index stated in the table (for design HA ... HC see table design H) satisfies the following conditions:

$$\text{thermal index} \geq \frac{n_2^{1,12} \cdot F_{ad} \cdot (D + d)}{4\ 000\ 000}$$

where:  
 $n_2$  [min<sup>-1</sup>] speed of low speed shaft  
 $D, d$  [mm] external and internal diameters of thrust bearing (see following tables)  
 $F_{ad}$  axial dynamic force [daN]

Whenever the verification is not satisfactory, use forced cooling: with **fan** (for the gear reducer only), with **coil**, with **independent cooling unit** with oil/water heat exchanger.

On request, the product is supplied with the **calculation of thrust bearing life**, according to ISO 281, considering the load conditions ( $F$  axial dynamic,  $n_2$ ) of Customer application.

**Ausführung N**

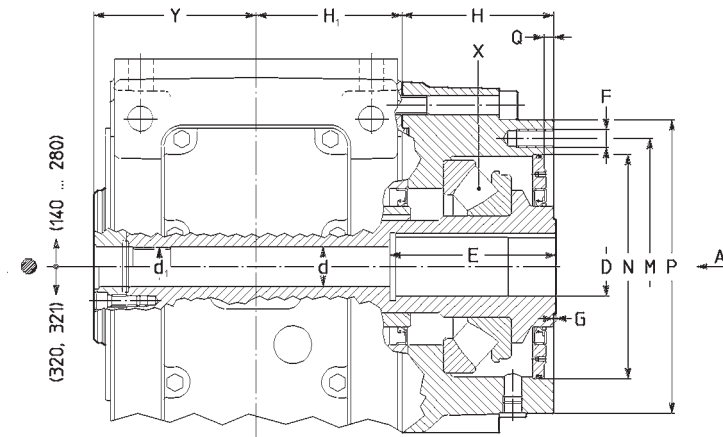

**Design N**

senkrechte Achse (Bauform B3)  
vertical axis (mounting position B3)

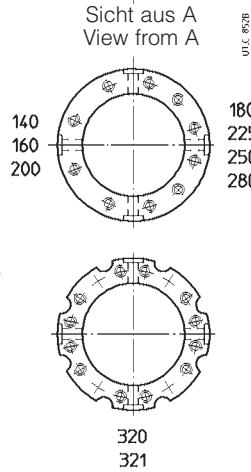

**Ausführung N** (für normale Belastungen): Verkeilung mit Passfeder und Schraubenextraktion **nur** von Extruderseite

**Design N** (for normal loads): extruder screw fitting with key and screw extraction on extruder side **only**

- Position der Bezugsrille.
- Position of the reference groove.

Getriebegröße Gear reducer size	Wärmezahl Thermal index	Lager - Bearing				Abmessungen - Dimensions												
		X	D ø	d ø	C kN	d ø	d <sub>1</sub>	D ø max H7	E max	F <sup>1)</sup>	G	H	H <sub>1</sub>	M ø	N ø H7	P ø	Q 0 + 0,5	Y ≈
<b>140</b>	200	294 17	180	85	633	34	TpF32	45	143	M 16 <sup>8</sup>	1	131	103,5	208	180,5	240	8	131
<b>160</b>	200	294 17	180	85	633	34	TpF32	55	143	M 16 <sup>8</sup>	1	131	128,5	208	180,5	240	8	143
<b>180</b>	265	294 20	210	100	863	34	TpF32	60	173	M 16 <sup>12</sup>	1	150	128,5	243	215	275	10	159
<b>200</b>	335	294 22	230	110	1010	43	TpF42	70	173	M 20 <sup>8</sup>	1	164	158	278	243	318	10	176
<b>225</b>	425	294 26	270	130	1380	43	TpF42	75	193	M 20 <sup>12</sup>	1	182	158	318	283	358	10	190
<b>250</b>	630	294 30	300	150	1610	43	TpF42	90	253	M 24 <sup>12</sup>	1,5	222	195	400	358	450	12	226
<b>280</b>	630	294 34	340	170	2020	43	TpF42	100	253	M 24 <sup>12</sup>	1,5	222	195	400	358	450	12	242
<b>320, 321</b>	1 000	294 40	400	200	2760	72	—	110	303	M 30 <sup>12</sup>	1,5	277	241	535	483	595	12	274

1) Nutzlänge des Gewindes 2 · F.

1) Working length of thread 2 · F.

**Ausführung H**

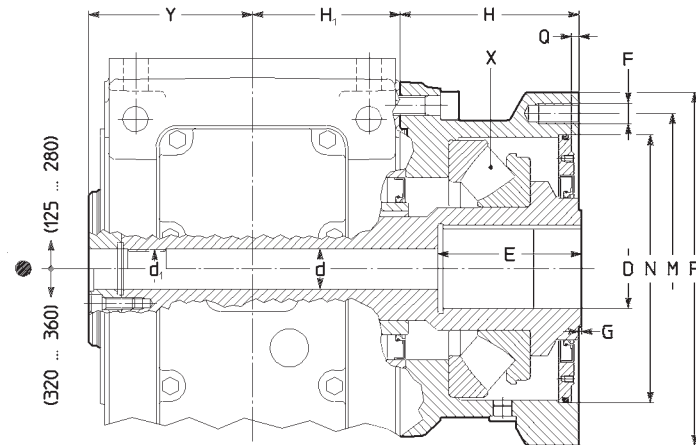

**Design H**

senkrechte Achse (Bauform B3)  
vertical axis (mounting position B3)

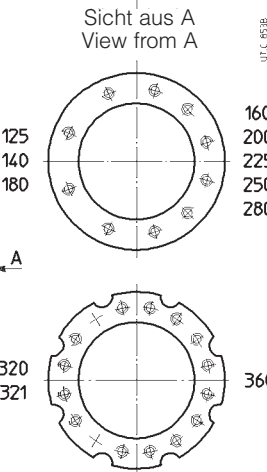

**Ausführung H** (für hohe Belastungen): Verkeilung mit Passfeder und Schraubenextraktion **nur** von Extruderseite

**Design H** (for high loads): extruder screw fitting with key and screw extraction on extruder side **only**

- Position der Bezugsrille.
- Position of the reference groove.

Getriebegröße Gear reducer size	Wärmezahl Thermal index	Lager - Bearing				Abmessungen - Dimensions												
		X	D ø	d ø	C kN	d ø	d <sub>1</sub>	D ø max H7	E <sup>3)</sup> max	F <sup>1)</sup>	G	H	H <sub>1</sub>	M ø	N ø H7	P ø	Q 0 + 0,5	Y ≈
<b>125</b>	160	294 16	170	80	575	27	TpF25	50	98	M 14 <sup>8</sup>	1	120	103,5	208	180,5	240	8	116
<b>140</b>	236	294 18	190	90	702	34	TpF32	55	118	M 16 <sup>8</sup>	1	150	103,5	243	215	275	8	131
<b>160</b>	236	294 20	210	100	863	34	TpF32	60	133	M 16 <sup>12</sup>	1	150	128,5	243	215	275	8	143
<b>180</b>	300	294 22	230	110	1010	34	TpF32	70	133	M 20 <sup>8</sup>	1	164	128,5	278	243	318	10	159
<b>200</b>	375	294 26	270	130	1380	43	TpF42	80	158	M 20 <sup>12</sup>	1	182	158	318	283	358	10	176
<b>225</b>	475	294 30	300	150	1610	43	TpF42	90	158	M 24 <sup>12</sup>	1	202	158	350	308	400	10	190
<b>250</b>	630	294 34	340	170	2020	43	TpF42	105	188	M 24 <sup>12</sup>	1,5	222	195	400	358	450	12	226
<b>280</b>	710	294 38	380	190	2480	43	TpF42	120	188	M 30 <sup>12</sup>	1,5	242	195	435	383	495	12	242
<b>320, 321</b>	1 000	294 48	440	240	2990	72	—	140	218	M 30 <sup>12</sup>	1,5	277	241	535	483	595	12	274
<b>360<sup>2)</sup></b>	1 000	294 52	480	260	3510	72	—	160	203	M 30 <sup>16</sup>	1,5	277	241	535	483	595	12	293

1) Nutzlänge des Gewindes 2 · F.  
 2) Größen 400 und 450 zur Verfügung: bitte rückfragen.  
 3) Für größere E reduziert Maß D (E, D wie Bauart N). Für Größen 125 und 360: D<sub>max</sub> und E<sub>max</sub> gelten jeweils 40 und 113, 130 und 303.

1) Working length of thread 2 · F.  
 2) Available sizes 400 and 450: consult us.  
 3) For higher E, D dimension decreases (E, D as design N). For sizes 125 and 360: D<sub>max</sub> and E<sub>max</sub> are respectively: 40 and 113, 130 and 303.

## 22 - Zubehör und Sonderausführungen

## 22 - Accessories and non-standard designs

### Ausführung HA: Keilung Extruderscheibe mit Passfeder

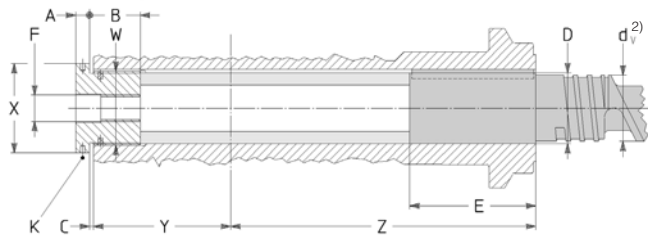

### Design HA: fitting extruder screw using key

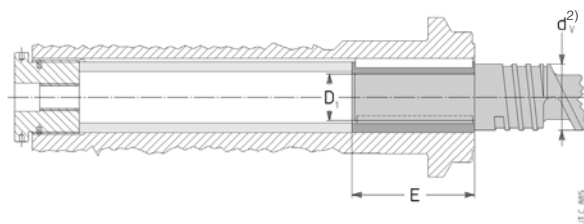

### Ausführung HB: Keilung Extruderschraube mit Keilprofil

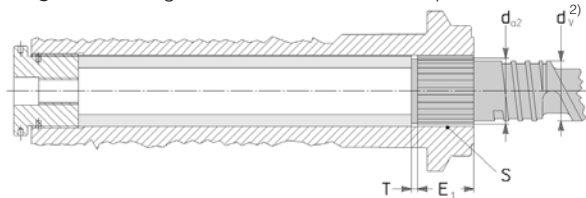

### Design HB: fitting extruder screw using spline profile

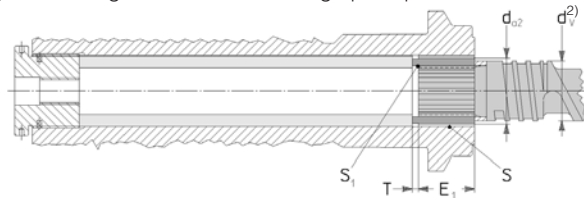

### Ausführung HC: Keilung Extruderschraube mit Keilprofil (Extrudergegenseite)

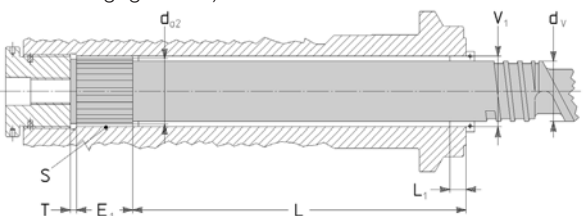

### Design HC: fitting extruder screw with spline profile on extruder opposite side

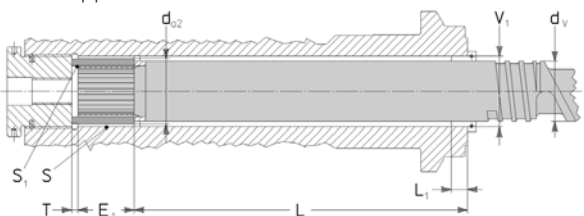

Schraubenextraktion auf **Extrudergegenseite**.  
Screw extraction on **extruder opposite side**.

Schraubenextraktion auf **Extrudergegenseite** und auch auf **Extrudersseite** ( $S_1 < d_{v1}$ ).  
Screw extraction on **opposite side** and on **extruder side** as well ( $S_1 < d_{v1}$ ).

Getriebe- größe Gear reducer size	Gewindebuchse - Threaded bush							Hohlwelle/Extruderendstück - Hollow shaft/extruder screw spigot												
	A	B	C	F	K <sup>1)</sup> Ø	X	W Ø	D <sup>2)</sup> Ø max H7	E max	D <sub>1</sub> Ø max H7	E <sub>1</sub>	Y	L	L <sub>1</sub> max	S max DIN 5480	d <sub>a2</sub> <sup>2)</sup> Ø	S <sub>1</sub> <sup>3)</sup> max DIN 5480	T	V <sub>1</sub> Ø H7	Z
<b>125</b>	15	38	3	M 24 × 2	6 × 8	68	M 55 × 1,5	52	105	35	40	110	253,5	13	50 × 2	46	35 × 2	6	52	224,5
<b>140</b>	15	42	3	M 24 × 2	6 × 8	78	M 62 × 1,5	60	105	40	48	125	285,5	15	60 × 2	56	40 × 2	6	60	254,5
<b>160</b>	18	48	3	M 24 × 2	6 × 8	88	M 70 × 1,5	67	130	45	52	136	312,5	17	65 × 3	59	45 × 2	6	67	279,5
<b>180</b>	18	53	3	M 24 × 2	6 × 8	100	M 80 × 1,5	75	130	52	60	150	327,5	19	75 × 3	69	55 × 2	6	75	293,5
<b>200</b>	24	64	4	M 36 × 3	8 × 11	118	M 95 × 2	90	150	63	72	167	368	22	90 × 3	84	65 × 3	8	90	341
<b>225</b>	24	74	4	M 36 × 3	8 × 11	140	M 110 × 2	105	180	75	85	180	378	26	105 × 4	97	75 × 3	8	105	361
<b>250</b>	24	86	6	M 36 × 3	8 × 11	155	M 125 × 3	120	210	85	95	206	438,5	30	120 × 4	112	90 × 3	11	120	418,5
<b>280</b>	30	96	6	M 36 × 3	10 × 14	175	M 140 × 3	135	230	95	108	222	451,5	34	135 × 4	127	100 × 3	11	135	438,5
<b>320, 321</b>	30	108	8	M 56 × 4	10 × 14	190	M 155 × 4	150	260	110	120	254	540	38	150 × 5	140	110 × 4	13,5	150	519,5
<b>360</b>	30	126	8	M 56 × 4	10 × 14	225	M 185 × 4	170	300	125	150	273	511	45	180 × 5	170	135 × 5	13,5	180	519,5

1) Nr. 4 Bohrungen für Größen 125 ... 250, Nr. 6 Bohrungen für Größen 280 ... 360.

2) Mass  $d_v$  muss nicht größer als  $(0,94 \div 0,97) \cdot D$  oder  $(0,94 \div 0,97) \cdot d_{a2}$ .

3) Verzahnungsklasse DIN9, Toleranz 9H.

\* Zubehör in grau ist kundenseitig.

1) No. 4 holes for sizes 125 ... 250, No. 6 holes for sizes 280 ... 360.

2)  $d_v$  dimension must not be higher than  $(0,94 \div 0,97) \cdot D$  or  $(0,94 \div 0,97) \cdot d_{a2}$ .

3) Tothing class DIN9, Tolerance 9H.

\* Grey objects are on Buyers care.

### Schmierung

Die Schmierung des **Extruderlagers** ist immer **separat** vom Getriebe, ausser mit unabhängiger Kühleinheit, wenn sie für die Kühlung **sowohl** des Getriebes **als auch** desselben Lagers angewendet wird.

Die **separate Schmierung** des Extruderlagers verbessert erheblich die Zuverlässigkeit und die Dauer des Axiallagers; die Separation zwischen Getriebe und Lager ist durch einen Dichtring realisiert. Das Lager wird mit metallischer Einfüllschraube mit Filter und Ventil, Ölstand- und Auslaufschraube ausgeliefert.

Mit separater Schmierung, für das Extruderlager Synthetiköl mit polyalphaolephine-Basis anwenden (MOBIL SHC XMP 680, CASTROL Tribol 1510/680) mit Viskositätsgrad nach **ISO 680 cSt**.

Mit der **gemeinsamen Schmierung** (mit unabhängiger Kühleinheit, wenn sowohl für die Kühlung des Getriebes als auch für die Kühlung des Lagers angewendet wird) muss der ISO-Viskositätsgrad nach Kap. 21 sein und das Öl muss synthetisch auf polyalphaolephine-Basis sein.

Die Richtölmengen des Extruderlagers sind auf folgender Tabelle hingewiesen: auf jeden Fall ist die genaue Menge für das Lager (separate Schmierung) und für das Getriebe (gemeinsame Schmierung) durch jeweils das Lager- oder das Getriebe-niveau bestimmt.

### Lubrication

The lubrication of **extruder support** is always **separate** from the gear reducer, except in presence of the independent cooling unit, if applied to cool **both** the gear reducer and the support.

The **separate lubrication** of extruder support sensibly improves the reliability and real life of the axial bearing; the separation between gear reducer and support is granted by a seal ring. Furthermore, the support is supplied with metal filler plug with filter and valve, level and draining plug.

With separate lubrication, for the extruder support, use polyalphaolephines based synthetic oil (MOBIL SHC XMP 680, CASTROL Tribol 1510/680) with **ISO 680 cSt** viscosity grade.

With **joint lubrication** (in presence of independent cooling unit, if applied to cool both the gear reducer and the support), lubricant ISO viscosity grade must be according to the instructions given in ch. 21 and oil must be polyalphaolephine based synthetic type.

The approximate extruder support lubricant quantities are stated in the following table: anyway, the exact oil quantity to be filled with in the support (separate lubrication) or the gear reducer (joint lubrication) is given by the support or gear reducer level, respectively.



Ausführung für Extruder mit Zusatzkühlung mit 2 Lüftern.  
Design for extruders with artificial double fan cooling.

Zusatz zur **Bestellbezeichnung: Ausführung für Extruder N, H, HA, HB oder HC.**

**Ex** **Getriebe in ATEX-Ausführung II 2 GD und 3 GD**

Die Stirnrad- und Kegelstirnradgetriebe können nach ATEX 94/9/ EWG geliefert werden, um die Anwendung in potentiell explosiblen Zonen zu erlauben, und zwar Kategorie **2 GD** (für Betrieb in Zonen 1 (Gas), 21 (Staub): Vorhandensein von möglicher explosibler Atmosphäre) und **3 GD** (für Betrieb in Zonen 2 (Gas), 22 (Staub): Vorhandensein von **unmöglich** explosibler Atmosphäre) mit Außentemperatur 135 °C (T4).

Die Hauptvarianten dieses Produkts sind:

- Dichtringe aus Fluorgummi;
- Metallschrauben; Einfüllschraube mit Filter und Ventil;
- **Sondertypenschild mit ATEX-Marke und Anwendungsgrenzwerten.**

Für die Kategorie 2 GD<sup>1)</sup>, je nach **minimalem Kontrollintervall**, auch:

- 2 GD monatliche Kontrolle
- Doppeldichtringen auf der langsamlauf. Welle;
- 2 GD dreimonatliche Kontrolle (Größen 125 ... 360)
- Doppeldichtringe auf der langsamlauf. Welle
- Öltemperaturfühler
- etwaige Lagertemperaturfühler;

diese Lösung ist empfohlen, wenn das Getriebe schwierig zugänglich ist oder wenn die Kontrollenfrequenz zu vermindern ist.

1) Das Vorhandensein der Lagerschmierpumpe erfordert einen oder mehrere zusätzliche Lagertemperaturfühler.

Betriebsumgebungstemperatur: -20 ÷ +40 °C (0 ÷ +40 °C für die Getriebe, die mit Lagerschmierpumpe ausgerüstet sind  $\emptyset$ ).

Die «Anweisungen zur Aufstellung und Wartung nach ATEX» U.T.D 123 (plus etwaige zusätzl. Dokumentation) **werden immer mit jedem Getriebe ausgeliefert**; jede Anweisung muss sorgfältig angewendet werden. Bei Bedarf, bitte rückfragen.

**Achtung:** Für Kat. 2 GD sind die Sonderausführungen «Langsamlaufende Hohlwelle mit Spannsatz auf Maschinenseite», «Bimetallischer Thermostat» und «Mechanischer Abtriebsdrehmomentbegrenzer» nicht möglich.

**Auswahl der Getriebegröße**

Für die Bestimmung der Getriebegröße folgen Sie die Anweisungen in Kap. 6 und folgende Punkte:

- max Antriebsdrehzahl  $n_1 \leq 1\,500 \text{ min}^{-1}$ ;
- **erforderlicher Betriebsfaktor** muss laut Kap. 5 bestimmt und um die Faktoren der Tab. 1 erhöht werden und darf **nie kleiner als 1** sein.

**Tabelle 1. Korrekturfaktor fs**

	II 2 GD	II 3 GD
Erforderlicher fs-Korrekturfaktor	1,25	1,12

Die Wärmeleistung  $P_t$  nach der Nennwärmeleistung  $P_{N1}$  (s. **Tabelle auf Kap. 4**), Korrekturfaktor von **Tabelle 2** und Korrekturfaktoren vom Katalog (s. Kap. 8, 10, 13, 16) nachprüfen. Bei «Ausführung für Extruder» muss auch Wärmekennzahl um ft-Faktor der Tabelle 2 reduziert werden.

**Tabelle 2. Korrekturfaktor ft**

	II 2 GD	II 3 GD
ft-Korrekturfaktor (Wärmeleistung)	0,8 (0,71 für I, CI)	0,9 (0,8 für I, CI)

Zusatz zur **Bestellbezeichnung**<sup>2)</sup>:

**Ausführung nach ATEX II ...**

- ... **3 GD T4** Größen 40 ... 360
- ... **2 GD T4 monatliche Kontrolle** Größen 40 ... 360
- ... **2 GD T4 dreimonatliche Kontrolle** Größen 125 ... 360

2) Diese Bezeichnung, bei Getriebemotor, bezieht sich **nur auf das Getriebe.**

Getriebe- größe Gea reducer size	Quantità indicativa olio sopporto estrusore [l] Approximate oil quantity extruder support [l]
<b>140, 160</b>	0,8
<b>180</b>	1,1
<b>200</b>	1,5
<b>225</b>	2,5
<b>250, 280</b>	4
<b>320 ... 360</b>	5,5

Supplementary description when ordering by **designation: design for extruders N, H, HA, HB or HC.**

**Ex** **Gear reducer design ATEX II 2 GD and 3 GD**

Parallel and right angle shaft gear reducers and gearmotors may be supplied according to European Community Directive ATEX 94/9/EC in order to be used in potentially explosive atmospheres – category **2 GD** (for operation in zones 1 (gas), 21 (dust): **probable** presence of explosive atmosphere) and **3 GD** (for operation in zones 2 (gas), 22 (dust): **improbable** presence of explosive atmosphere) – with surface temperature T 135 °C (T4).

These are the main variations of the product:

- fluoro-rubber seal rings;
- metal plugs; filler plug with filter and valve;
- special name plate with ATEX mark and indication of application limits.

For category 2 GD<sup>1)</sup>, depending on **minimum control intervals**, also:

- 2 GD monthly control
- double seal rings on low speed shaft;
- 2 GD quarterly control (sizes 125 ... 360)
- double seal rings on low speed shaft;
- oil temperature probe;
- bearing temperature probes, if any;

this solution is advisable when the gear reducer has difficult access or when a decrease in control frequency is desired.

1) The presence of bearing lubrication pump requires one or more additional bearing temperature probes.

Operating ambient temperature: -20 ÷ +40 °C (0 ÷ +40 °C for gear reducers supplied with bearing lubrication pump  $\emptyset$ ).

The «**Installation and maintenance instructions for ATEX gear reducers**» U.T.D 123 (with the additional documentation, if any) are **integral part of the supply** of each gear reducer; every indication stated in it must be carefully applied. In case of needs, consult us.

**Warning:** for cat. 2 GD non-standard designs «Hollow low speed shaft with shrink disc side to machine» and «Bi-metal type thermostat», «Mechanical torque limiter on output shaft» are not possible.

**Gear reducer size selection**

Determine the size of gear reducer as indicated in ch. 6 considering following additional limitations:

- maximum input speed  $n_1 \leq 1\,500 \text{ min}^{-1}$ ;
- **service factor requested** determined according to ch. 5 increased with the factors stated in table 1 – **never lower than 1**.

**Table 1. Corrective factor fs**

	II 2 GD	II 3 GD
Corrective factor of fs required	1,25	1,12

Verify, at last, the thermal power  $P_t$  with regard to the nominal thermal power  $P_{N1}$  (see **table in ch. 4**), to the corrective factor stated on **table 2** and to the catalogue corrective factors (see ch. 8, 10, 13, 16). In case of «Design for extruders», the extruder support thermal index stated on tables must be reduced accordingly to the following ft factor (table 2), as well.

**Table 2. Corrective factor ft**

	II 2 GD	II 3 GD
Corrective factor of ft (thermal power)	0,8 (0,71 for I, CI)	0,9 (0,8 for I, CI)

Additional description when ordering by **designation**<sup>2)</sup>:

**design ATEX II ...**

- ... **3 GD T4** sizes 40 ... 360
- ... **2 GD T4 monthly control** sizes 40 ... 360
- ... **2 GD T4 quarterly control** sizes 125 ... 360

2) For gearmotors, this designation refers to the only **gear reducer part.**

**Motoren:** in folgender Tabelle sind die minimalen Forderungen für die mit Getrieben in potentiell explosiblen Atmosphären aufzustellenden Motoren und für die von Rossi Motoriduttori ausgelieferten Motoren.

**Motors:** the following table contains the minimum requirements for motors to be installed with gear reducers in areas with potentially explosive atmospheres and the motors which can be supplied by Rossi Motoriduttori.

Zone Zone	Erforderte Kategorie der Apparate <sup>1)</sup> Required category of equipment <sup>1)</sup>		Verfügbar Available			
	Getriebe Gear reducer	Motor motor	Getriebe Gear reducer	Standardmotor Standard motor		Bremsmotor Motore with brake
				≤ 132	≥ 160	
<b>1</b>	2 G	2 G EExe mit Thermistoren 2 G EExd oder Pt100 2 G EExde with thermistors or Pt100	2 GD c, k T135°C (T4)	2 GD EEx d <sup>3)</sup> IIB T135°C (T4)	2 GD EEx d <sup>3)</sup> IIB T135°C (T4)	2 GD EEx d <sup>3)</sup> IIB T135°C (T4)
<b>21</b>	2 D	2 D IP65		2 D T135°C IP65 <sup>4)</sup>		
<b>2</b>	3 G	3 G EExn -	3 GD c, k T135°C (T4) <sup>5)</sup>	3 GD EEx nA II T135°C (T3) <sup>4)</sup>	3 GD EEx nA II T135°C (T3) <sup>4)</sup>	3 G EEx nA,c II T3 <sup>4)</sup>
<b>22</b>	3 D	3 D IP54 <sup>2)</sup> -				3 D c T135°C IP55 <sup>4)</sup>

- 1) Die Ausführung für Zone 1 ist auch für Zone 2 geeignet; die Ausführung für zone 21 ist auch für Zone 22 geeignet.
- 2) Für leitende Stäube muss der Motor 2 D IP 65 sein.
- 3) EEx de auch verfügbar.
- 4) Mit Fremdlüfter nicht lieferbar.
- 5) Bei für Zone 2 konzipiertem Getriebemotor wird die Gesamttemperaturklasse (von Motor und Getriebe) T3.

- 1) The devices suitable for zone 1 are also suitable for zone 2; similarly, the devices suitable for zone 21 are also suitable for zone 22.
- 2) For conductive dusts motor must be 2 D IP 65.
- 3) Also EEx de available.
- 4) It cannot be supplied with independent cooling fan.
- 5) For gearmotors used in zone 2, the temperature class of the assembly (gear reducer and motor) becomes T3.

EEx e Schutzmethode für elektrische Vorrichtungen: Erhöhte Sicherheit, Bezugsrichtlinie EN 50019;  
 EEx d Schutzmethode für elektrische Vorrichtungen: Druckfeste Kapselung, Bezugsrichtlinie EN 50018;  
 EEx de Schutzmethode für elektrische Vorrichtungen: Kombination der 2 o.g. Methoden, Bezugsrichtlinien EN 50018 und EN 50019;  
 EEx nA Schutzmethode für elektrische Vorrichtungen: nicht funkend, Bezugsrichtlinie EN 50021;  
 c Schutzmethode für nicht-elektrische Vorrichtungen: Konstruktive Sicherheit, Bezugsrichtlinie prEN 13463-5;  
 k Schutzmethode für nicht-elektrische Vorrichtungen: Flüssigkeitskapselung, Bezugsrichtlinie prEN 13463-8;  
 Für die Schutzmethode der elektrischen Vorrichtungen für die Anwendung bei Brennstäuben: Bezugsrichtlinie **EN 50281**.

EEx e type of protection for electrical apparatus: increased safety, reference standard EN 50019;  
 EEx d type of protection for electrical apparatus: flameproof, reference standard EN 50018;  
 EEx de type of protection for electrical apparatus: combination fo 2 previous types, reference standard EN 50018 e EN 50019  
 EEx nA type of protection for electrical apparatus: non-sparking, reference standard EN 50021;  
 c of protection for non-electrical equipment: costructional, reference standard prEN 13463-5;  
 k type of protection for non-electrical equipment: liquid immersion, reference standard prEN 13463-8;  
 For type of protection of electrical apparatus for use in the presence of combustibile dust: reference standard **EN 50281**.

**Sonstiges**

- **Synchrone Mehrfachantriebe:** Getriebe und Getriebemotoren mit Zahnradgetriebe ICI können für Mehrfachantriebe zusammen mit Getrieben gleicher Größe R CI UO3A ... UO3Esin angewendet werden, die immer die gleiche Übersetzung haben (s. auch Kap. 10).

**Miscellaneous**

- **Synchronous multiple drives:** gear reducers and gearmotors having train of gears ICI can be applied for multiple drives together with gear reducers of the same size R CI UO3A ... UO3Esin, all with the same transmission ratio (see also ch. 10).

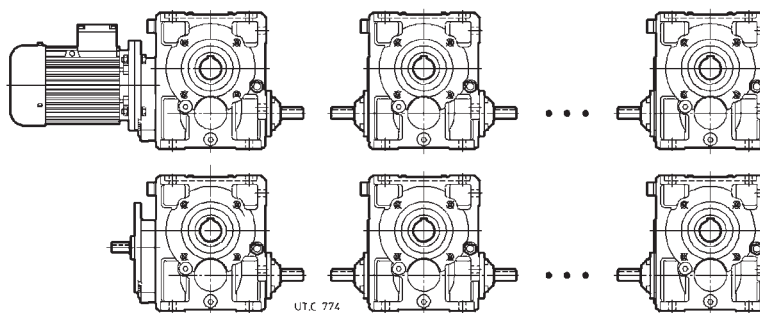

Auf Anfrage können die Getriebe R CI in der Ausführung UO3A ... UO3Esin auch für die Größen 125 ... 200 geliefert werden. In diesem Fall, nachdem die Einlaufgetriebe- oder Einlauftriebemotorgröße oder -übersetzung bestimmt hat, müssen die Getriebe R CI mit dieser selben Größe oder Übersetzung -gegeben durch die Übersetzung des Einlaufgetriebes geteilt durch die Übersetzung der Stirnradvorstufe - ausgewählt werden (s. Kap. 6); die Leistungen bleiben dieselben des Einlaufgetriebes oder -triebemotors ICI.

On request, gear reducers R CI can be supplied in the design UO3A ... UO3Esin also for the sizes 125 ... 200. In this case, after having defined the size and the ratio of the initial gear reducer or gearmotor ICI, the gear reducers R CI must be selected with this size and transmission ratio given by the one of the initial gear reducers divided by the transmission ratio of the first cylindrical reduction stage (see ch. 6); performances will remain the same of the initial gear reducer or gearmotor ICI.

Ausführungen (Drehrichtung), Abmessungen und Bauformen der Getriebe R CI 125 ... 200 UO3A ... UO3Esin können durch diejenigen der ähnlichen Getriebe R ICI (s. Kap. 10) gegeben werden. Bei Bedarf bitte rückfragen.

Designs (direction of rotation), dimensions and mounting position of the gear reducers R CI 125 ... 200 UO3A ... UO3Esin can be deducted from the ones of the similar gear reducers R ICI (see ch. 10). If necessary, consult us.

- Getriebemotoren mit:
  - **HFV Bremsmotor** (auch Einphasenmotor) mit Gs-**Sicherheits- und/oder Standbremse** (Größen 63 ... 132) mit fast demselben Raumbedarf eines normalen Motors und Bremsmoment  $M_t \geq M_N$ , maximale Wirtschaftlichkeit;
  - **zweifach polumschaltbarem Motor**, normal **HF**, Bremsmotor **F0** und **HFV**: 2.4, 2.6, 2.8, 2.12, 4.6, 4.8, 6.8-polig;

- Gearmotors with:
  - **HFV** (also single-phase) **brake motor** with d.c. **safety and/or parking brake** (sizes 63 ... 132) having overall dimensions nearly the same of a standard motor and braking torque  $M_t \geq M_N$ , maximum economy;
  - **two-speed motor**, **HF** standard motor, **F0** and **HFV** brake motors: 2.4, 2.6, 2.8, 2.12, 4.6, 4.8, 6.8 poles;



## 22 - Zubehör und Sonderausführungen

- Motor: Gs-; Einphasen-; Explosionsschutz-; mit zweitem Wellenende; mit Sonderschutz, -spannung und -frequenz; mit Schützen gegen Überbelastungen und Überhitzungen;
- **Motor ohne Lüfter** mit Fremdkühlung für **natürliche Konvektion** (Größen 63 ... 112); normal angewendete Ausführung für Textilindustrie.

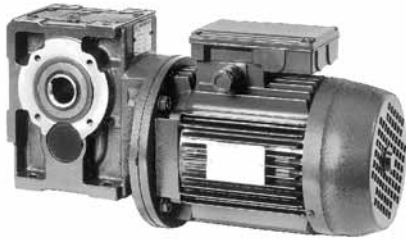

- Bauart mit **doppelter Motorisierung** und **gleicher** Geschwindigkeit (gleich- oder gegenläufig) oder **reduzierter** Geschwindigkeit (gleichläufig, Abschluss mit Freilauf) (s. Abb.).



- Gehäuse mit B14-Flansch **auf zwei Seiten** (Zahnradgetriebe 2l, 3l und 4l, Größen 63 ... 125).
- Antriebszentrierung (h8) für R Cl, R C2l.
- Getriebemotoren langes Modell Größen 250 ... 360.
- Getriebemotoren mit zwischengelegtem kompaktem Aggregat Schaltkupplung-Bremse oder Hydraulikkupplung-Bremse.
- Keilung mit Passfeder, Bronzenbuchse und Stellring für Zahnradgetriebe Cl, C2l oder Motorgröße < 200.
- Schutz des Spannsatzes an der Gegenseite der Maschine;
- Halbelastische und hydrodynamische Kupplungen.
- Ausführung für MR 2l mit **durchgehender** langsamlaufender Welle.
- **Unabhängige Kühleinheit mit Öl/Luft** oder **Öl/Wasser Wärmeaustauscher** für zusätzliche Kühlung und Zwangsschmierung (s. Kat. H).
- Ölstillstandsheizung für Anläufe bei niedriger Umgebungstemperatur (Größen  $\geq 125$ : immer Ölstandsthermometer vorsehen).
- Ölstand- und -temperaturanzeiger (Größen  $\geq 160$ ).
- Ölstandfernanzeige mit **Schwellensignal** (Größen  $\geq 160$ ).
- Öltemperaturfühler: Fühler Pt100 (G 3/4" bei Größen 160 ... 280, G 1" bei Größen 320 ... 360).
- Lagerwiderstandsthermometer (Gr.  $\geq 250$ ): Pt100-Fühler.
- Fernanzeigergerät für Öltemperatur (oder Lager-) mit Schwellensignal (Gr.  $\geq 160$ ).
- Mögliche Sonderlackierungen:
  - **1 K-Außenlackierung:** Rostschutzgrundierung mit Zinkphosphaten plus Synthetiklack blau RAL 5010 DIN 1843;
  - **2 K-Außenlackierung:** 2 K-Rostschutzgrundierung auf Epoxyd-Polyamid Basis plus 2-K-PU Lack blau RAL 5010 DIN 1843;
  - **2 K-Innenlackierung:** Gegen synthetische Öle auf Polyglykole Basis beständig (Größen 125 ... 360).
- Sonderdichtringe; **Doppeldichtung** (Größen  $\geq 80$ ; schnelllauf. Welle, rückfragen); **geschützte** Dichtung mit Labyrinth und Fettpressbüchse (Größen  $\geq 180$ ).

- Getriebe und Getriebemotoren mit **mechanischem Drehmomentbegrenzer** auf **Abtriebsseite** Getriebegrößen **50 ... 125** (außer Größen 64, 81).
- Getriebebauart mit mechanischem **Friktionsdrehmomentbegrenzer** (Friktionsbeläge ohne Asbest) in kompakter Ausführung, durch ein großes übertragbares Drehmoment – bis **160 daN m** – und hohe Qualität gekennzeichnet.

Das Modul schützt den Antrieb vor plötzlichen Überbelastungen und schließt hierbei die Folgewirkungen des Trägheitsmomentes von vorgeschalteten und, obwohl da Getriebe selbsthemmend ist (Begrenzer abtriebsseitig!), von nachgeschalteten Massen aus.

## 22 - Accessories and non-standard designs

- motor featuring: d.c. supply; single-phase; explosion-proof; with second shaft end; with non-standard protection, voltage and frequency; provided with devices against overloads and overheating;
- **motor without fan** cooled **by natural convection** (sizes 63 ... 112); design for textile industry.

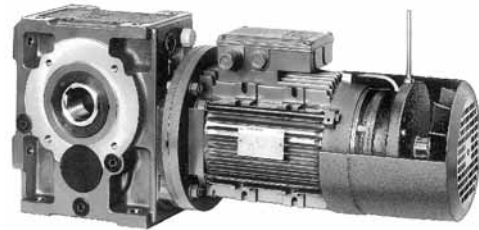

- Design with **2nd motor** with **identical** speed (same or different direction of rotation) or **reduced** speed (same direction of rotation, free-wheel coupling) (see picture).



- Casing with B14 flange **on two faces** (train of gears 2l, 3l and 4l sizes 63 ... 125).
- In put side spigot (h8) for R Cl, R C2l.
- Long model gearmotors sizes 250 ... 360.
- Gearmotors with interposed compact clutch-brake or fluid coupling/brake unit.
- Keying with key, bronze bush and hub clamp for trains of gears Cl, C2l or for motor size < 200.
- Opposite side to machine shrink disc protection.
- Semi-flexible and hydrodynamic couplings.
- Design for MR 2l with **through** low speed shaft.
- **Independent cooling unit, made up of oil/air or oil/water heat exchanger** for forced cooling and lubrication (see cat. H).
- Oil heater for start at low ambient temperature (size  $\geq 125$ : always necessary also oil temperature probe).
- Level plug with oil thermometer (sizes  $\geq 160$ ).
- Remote **threshold** signalling of oil level (sizes  $\geq 160$ ).
- Oil temperature probe: Pt100 probe (G 3/4" for sizes 160 ... 280, G 1" for sizes 320 ... 360).
- Bearing temperature probe (size  $\geq 250$ ): Pt100 probe.
- Remote oil (or bearing) temperature indicator instrument with set point (size  $\geq 160$ ).
- Special paint options:
  - **external, single-compound:** antirust zinc primer plus blue RAL 5010 DIN 1843 synthetic paint;
  - **external, dual-compound:** dual-compound epoxy-polyamidic antirust primer plus dual-compound blue RAL 5010 DIN 1843 polyurethane enamel;
  - **internal, dual-compound:** unaffected by polyglycol synthetic oils (sizes 125 ... 360).
- Special seal rings; **double** seal (low speed shaft, size  $\geq 80$ ; high speed shaft, consult us); **shielded** labyrinth seal with grease nipple (size  $\geq 180$ ).

- Gear reducers and gearmotors with **mechanical torque limiter** on **output** shaft, gear reducer sizes **50 ... 125** (excluding sizes 64, 81). Gear reducer design with mechanical **friction** type torque limiter (friction surfaces without asbestos), compact and with high transmissible torque – up to **160 daN m** – and top quality standards. It protects the drive from accidental overloads by excluding the effect of inertia loads transmitted from up-line masses and (the torque limiter being mounted on the output shaft) inertia loads transmitted from down-line masses.

## 22 - Zubehör und Sonderausführungen

## 22 - Accessories and non-standard designs

Sobald das übertragene Drehmoment das Eichungsmoment überschreitet, erfolgt der «Schlupf» des Antriebs, der jedoch mit einem dem Eichungsmoment des Begrenzers entsprechenden Drehmoment im Eingriff **bleibt**; der Schlupf endet bei Wiederherstellung des normalen Lastzustands; bei äußerst kurzzeitigen Überbelastungen kann die Maschine (nach Abbremsung oder Stillstand) ohne abermaliges Einschalten den normalen Betrieb wiederaufnehmen.

When the transmitted torque tends to exceed the setting value the drive «slips» although it **remains** engaged with torque equal to the limiter setting value; slipping stops as soon as the load returns to normal; in the case of very brief overloads the driven machine will continue normal operation (after decelerating or stopping) without requiring reset procedures.

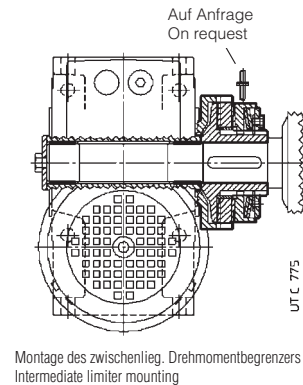
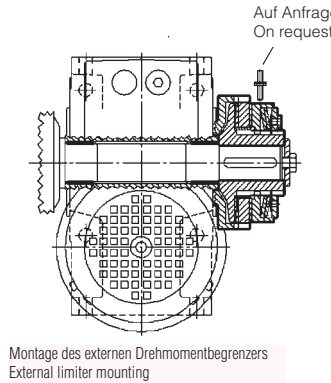
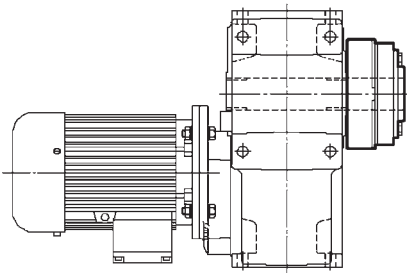

Mit diesem System ist auch die **Aufsteckbefestigung** sowohl mit **externem** (besserer Zugang) als auch **zwischenliegendem** (erhöhter Unfallschutz) Begrenzer möglich.

Auf Anfrage: Gleitungssonde. Bei anderen Details s. **gesonderte Unterlage**.

The system also permits **shaft mounting** with the limiter mounted **externally** (easily accessible), or in the **intermediate** position (better safety protection).

On request slide detector. For more details see **specific literature**.

### – MLA und MLS Modul, mechanischer Drehmomentbegrenzer auf Antriebsseite, Motorgrößen 80 ... 200 (180 für MLS).

### – MLA and MLS unit, mechanical torque limiter on input shaft, motor sizes 80 ... 200 (180 for MLS).

Mechanisches Drehmomentbegrenzermodul zum Einbau zwischen Getriebe und Normmotor nach IEC in Bauform B5 (bzw. Breitkeilriemen- oder Planetenverstellgetriebemotor) oder bei **Kombieinheiten** zwischen Einlaufstirnradgetriebe (Koax. Wellenanordnung) und Auslaufgetriebe Größen **63 ... 280**.

Mechanical torque limiter unit to be interposed between gear reducer and B5 mounting position motor standardized to IEC or (wide belt or planetary motor-variator) or, in **combined units**, between the initial coaxial gear reducer and the final gear reducer, sizes **63 ... 280**.

Extrem kompakte Axialausführung; optimierte Belastbarkeit durch lebensdauer geschmierte Schräglager mit zweireihigen Kugeln (Motorgröße  $\leq 112$ ) oder Kegelrollenlager nach «O»-Typ.

Axially ultra-compact design: excellent load bearing with life lubricated double row angular contact ball bearings (motor size  $\leq 112$ ) or «O» disposed taper roller bearings.

Das Modul schützt den Antrieb vor plötzlichen Überbelastungen und schließt hierbei die Folgewirkungen des Trägheitsmomentes von vorgeschalteten und von nachgeschalteten Massen aus.

The unit protects the drive from accidental overloads by excluding inertia loads transmitted from up-line masses and down-line masses.

**LA Modul ist vom Friktionstyp** (Frikitionsbeläge ohne Asbest). Sobald das übertragene Drehmoment das Eichungsmoment überschreitet, erfolgt der «Schlupf» des Antriebs, der jedoch mit einem dem Eichungsmoment des Begrenzers entsprechenden Drehmoment im Eingriff **bleibt**; der Schlupf endet bei Wiederherstellung des normalen Lastzustands; bei äußerst kurzzeitigen Überbelastungen kann die Maschine (nach Abbremsung oder Stillstand) ohne abermaliges Einschalten den normalen Betrieb wiederaufnehmen.

**LA unit is friction type** (friction surfaces without asbestos). When the transmitted torque tends to exceed the setting, the drive «slips» although it **remains** engaged and transmits torque equal to the limiter setting value; slipping stops as soon as the load returns to normal; in the case of very brief overloads the driven machine will continue normal operation (after decelerating or stopping) without requiring reset procedures.

**LS unit is ball type**. When the transmitted torque tends to exceed the setting, the drive is «disengaged» so it **does not remain** connected. The driven machine will therefore stop.

**LS Modul ist vom Kugeltyp**. Sobald das übertragene Drehmoment das Eichungsmoment überschreitet, erfolgen das «Auskuppeln» des Antriebs, der also **nicht** im Eingriff **verbleibt**, und der Stillstand der Maschine.

LA and LS units are mechanically interchangeable. On request slide detector. For more details see **specific literature**.

Die Typen LA und LS sind mechanisch austauschbar. Auf Anfrage: Gleitungssonde. Bei anderen Details s. **gesonderte Unterlage**.

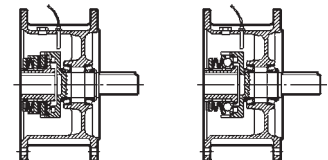
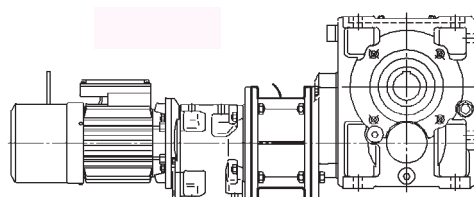
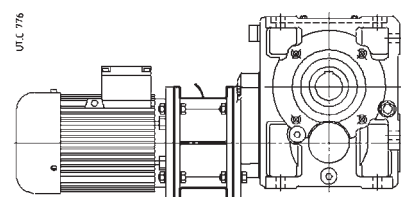

– Verschleiß- und wartungsfreie mechanische Sonderdichtung für MR 21, 31 Größe  $\geq 160$  für eine einzige Drehrichtung (patentiert).

– Antriebe mit Lagerung - Motor, Kupplung, etwaige Bremse, zweiter Antrieb - zur Aufsteckbefestigung.

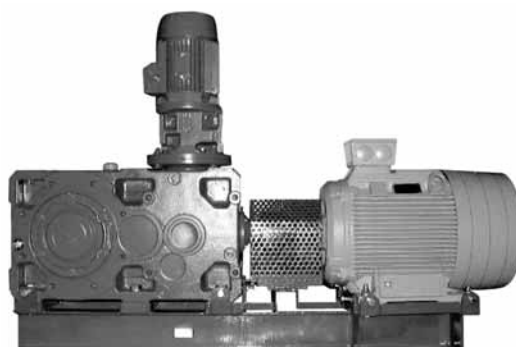

– Special maintenance-free wearproof mechanical seal for MR 21, 31 sizes  $\geq 160$ , for one direction of rotation only (patented).

– Driving group complete of base - motor, coupling, brake, if any, second drive for shaft - mounting arrangements.

## 23 - Technische Formeln

Wichtigste Formeln für mechanische Getriebe nach dem Technischen Maßsystem und dem Internationalen Einheitensystem (SI).

## 23 - Technical formulae

Main formulae concerning mechanical drives, according to the Technical System and International Unit System (SI).

Größe	Size	Mit Einheit technischen Maßsystems With Technical System units	Mit SI-Einheit With SI units
<b>Anlauf- oder Auslaufzeit</b> in Abhängigkeit von einer Beschleunigung oder Verzögerung, von einem Anlauf- oder Bremsmoment	starting or stopping <b>time</b> as a function of an acceleration or deceleration, of a starting or braking torque	$t = \frac{v}{a} \text{ [s]}$	$t = \frac{J \cdot \omega}{M} \text{ [s]}$
<b>Geschwindigkeit</b> bei Drehbewegung	<b>velocity</b> in rotary motion	$t = \frac{Gd^2 \cdot n}{375 \cdot M} \text{ [s]}$ $v = \frac{\pi \cdot d \cdot n}{60} = \frac{d \cdot n}{19,1} \text{ [m/s]}$	$v = \omega \cdot r \text{ [m/s]}$
<b>Drehzahl</b>	<b>speed n</b> and <b>angular velocity <math>\omega</math></b>	$n = \frac{60 \cdot v}{\pi \cdot d} = \frac{19,1 \cdot v}{d} \text{ [min}^{-1}\text{]}$	$\omega = \frac{v}{r} \text{ [rad/s]}$
<b>Beschleunigung</b> oder Verzögerung in Abhängigkeit von einer Anlauf- oder Auslaufzeit	<b>acceleration</b> or deceleration as a function of starting or stopping time	$a = \frac{v}{t} \text{ [m/s}^2\text{]}$	$\alpha = \frac{\omega}{t} \text{ [rad/s}^2\text{]}$ $\alpha = \frac{M}{J} \text{ [rad/s}^2\text{]}$
<b>Winkelbeschleunigung</b> oder <b>-verzögerung</b> in Abhängigkeit von einer Anlauf- oder Auslaufzeit, von einem Anlauf- oder Bremsmoment	<b>angular acceleration</b> or deceleration as a function of a starting or stopping time, of a starting or braking torque	$\alpha = \frac{n}{9,55 \cdot t} \text{ [rad/s}^2\text{]}$ $\alpha = \frac{39,2 \cdot M}{Gd^2} \text{ [rad/s}^2\text{]}$	
<b>Anlauf- oder Auslaufweg</b> in Abhängigkeit von einer Beschleunigung oder Verzögerung einer End- oder Anfangsgeschwindigkeit	starting or stopping <b>distance</b> as a function of an acceleration or deceleration, of a final or initial velocity	$s = \frac{a \cdot t^2}{2} \text{ [m]}$ $s = \frac{v \cdot t}{2}$	$\varphi = \frac{\omega \cdot t}{2} \text{ [rad]}$
<b>Anlauf- oder Auslaufwinkel</b> in Abhängigkeit von einer Winkelbeschleunigung oder -verzögerung einer End- oder Anfangswinkelgeschwindigkeit	starting or stopping <b>angle</b> as a function of an angular acceleration or deceleration, of a final or initial angular velocity	$\varphi = \frac{n \cdot t}{19,1} \text{ [rad]}$	
<b>Masse</b>	<b>mass</b>	$m = \frac{G}{g} \text{ [kgf s}^2\text{/m]}$	m ist die Maßeinheit [kg] m is the unit of mass [kg]
<b>Gewicht</b> (Gewichtskraft)	<b>weight</b> (weight force)	G ist die Gewichtseinheit (Gewichtskraft) [kgf] G is the unit of weight (weight force) [kgf]	G = m · g [N]
<b>Kraft</b> bei senkrechter (Anheben), waagrecht, geneigter Linearbewegung ( $\mu$ = Reibungszahl; $\varphi$ = Neigungswinkel)	<b>force</b> in vertical (lifting), horizontal, inclined motion of translation ( $\mu$ = coefficient of friction; $\varphi$ = angle of inclination)	F = G [kgf] F = $\mu \cdot G$ [kgf] F = G ( $\mu \cdot \cos \varphi + \sin \varphi$ ) [kgf]	F = m · g [N] F = $\mu \cdot m \cdot g$ [N] F = m · g ( $\mu \cdot \cos \varphi + \sin \varphi$ ) [N]
<b>Schwungmoment <math>Gd^2</math>, Massenträgheitsmoment J</b> infolge einer Linearbewegung (numerisch $J = \frac{Gd^2}{4}$ )	<b>dynamic moment <math>Gd^2</math>, moment of inertia J</b> due to a motion of translation (numerically $J = \frac{Gd^2}{4}$ )	$Gd^2 = \frac{365 \cdot G \cdot v^2}{n^2} \text{ [kgf m}^2\text{]}$	$J = \frac{m \cdot v^2}{\omega^2} \text{ [kg m}^2\text{]}$
<b>Drehmoment</b> in Abhängigkeit von einer Kraft, einem Schwung oder Massenträgheitsmoment, einer Leistung	<b>torque</b> as a function of a force, of a dynamic moment or of a moment of inertia, of a power	$M = \frac{F \cdot d}{2} \text{ [kgf m]}$ $M = \frac{Gd^2 \cdot n}{375 \cdot t} \text{ [kgf m]}$ $M = \frac{716 \cdot P}{n} \text{ [kgf m]}$	$M = F \cdot r \text{ [N m]}$ $M = \frac{J \cdot \omega}{t} \text{ [N m]}$ $M = \frac{P}{\omega} \text{ [N m]}$
<b>Arbeit, Energie</b> bei der Linear- oder Drehbewegung	<b>work, energy</b> in motion of translation, in rotary motion	$W = \frac{G \cdot v^2}{19,6} \text{ [kgf m]}$ $W = \frac{Gd^2 \cdot n^2}{7160} \text{ [kgf m]}$	$W = \frac{m \cdot v^2}{2} \text{ [J]}$ $W = \frac{J \cdot \omega^2}{2} \text{ [J]}$
<b>Leistung</b> bei der Linear- oder Drehbewegung	<b>power</b> in motion of translation, in rotary motion	$P = \frac{F \cdot v}{75} \text{ [CV]}$ $P = \frac{M \cdot n}{716} \text{ [CV]}$ $P = \frac{U \cdot I \cdot \eta \cdot \cos \varphi}{736} \text{ [CV]}$ $P = \frac{U \cdot I \cdot \eta \cdot \cos \varphi}{425} \text{ [CV]}$	$P = F \cdot v \text{ [W]}$ $P = M \cdot \omega \text{ [W]}$ $P = U \cdot I \cdot \eta \cdot \cos \varphi \text{ [W]}$ $P = 1,73 \cdot U \cdot I \cdot \eta \cdot \cos \varphi \text{ [W]}$
<b>Leistung</b> die an der Welle eines Einphasenmotors abgegeben wird ( $\cos \varphi$ = Leistungsfaktor)	<b>power</b> available at the shaft of a single-phase motor ( $\cos \varphi$ = power factor)		
<b>Leistung</b> , die an der Welle eines Drehstrommotors abgegeben wird	<b>power</b> available at the shaft of a three-phase motor		

Anmerkung. Beschleunigung oder Verzögerung verstehen sich konstant; die Linear- oder Drehbewegungen verstehen sich geradlinig bzw. kreisförmig.

Note. Acceleration or deceleration are understood constant; motion of translation and rotary motion are understood rectilinear and circular respectively.

## Worldwide Sale and Service Network

### AUSTRALIA

ROSSI GEARMOTORS AUSTRALIA Pty. Ltd.  
AU - Perth WA  
Phone +61 8 94557399  
fax +61 8 94557299  
e-mail: info.australia@rossi-group.com  
www.rossigearmotors.com.au

ROSSI GEARMOTORS AUSTRALIA Pty. Ltd.  
AU - Victoria 3805  
Phone +61 3 9705 6066  
fax +61 3 9705 6043  
e-mail: info.australia@rossi-group.com  
www.rossigearmotors.com.au

ROSSI GEARMOTORS AUSTRALIA Pty. Ltd.  
AU - Sydney NSW  
Phone. +61 2 9723 0600  
fax +61 2 9723 0611  
e-mail: info.australia@rossi-group.com  
www.rossigearmotors.com.au

### CANADA

ROSSI GEARMOTORS  
Division of Habasit Canada Limited  
CA - Oakville, Ontario  
Phone +1 800 770 6750  
fax +1 800 268 2358  
e-mail: info.canada@habasit.com  
www.rossi-group.com

### CHINA

ROSSI GEARMOTORS CHINA P.T.I.  
CN - Shanghai  
Phone +86 21 3350 5345  
fax +86 21 3350 6177  
e-mail: info.china@rossi-group.com  
www.rossigearmotors.cn

### DENMARK

ROSSI GEARMOTORS SCANDINAVIA A/S  
DK - Frederiksberg  
Phone +45 38 11 22 42  
fax +45 38 11 22 58  
e-mail: info.denmark@rossi-group.com  
www.rossigearmotors.dk

### FRANCE

ROSSI MOTOREDUCTEURS SARL  
FR - Saint Priest  
Phone +33 472 477930  
fax +33 472 477949  
e-mail: info.france@rossi-group.com  
www.rossimotoreducteurs.fr

### GERMANY

HABASIT ROSSI GmbH  
DE - Eppertshausen  
Phone +49 6071 / 969 - 0  
fax +49 6071 / 969 - 150  
e-mail: info.germany@habasitrossi.com  
www.habasitrossi.de

### ICELAND

ROSSI GEARMOTORS SCANDINAVIA A/S  
DK - Frederiksberg  
Phone +45 38 11 22 42  
fax +45 38 11 22 58  
e-mail: info.denmark@rossi-group.com  
www.rossigearmotors.dk

### INDIA

ROSSI GEARMOTORS Pvt. Ltd.  
IN - Coimbatore  
Phone +91 422 262 7879  
fax +91 422 262 7214  
e-mail: info.india@rossi-group.com  
www.rossi-group.com

### MEXICO

ROSSI GEARMOTORS  
A Division of Habasit America  
US - Suwanee  
Phone +1 800 931 2044  
fax +1 678 288 3658  
e-mail: rossi.info@us.habasit.com  
www.habasitamerica.com

### NETHERLANDS

HABASIT NETHERLANDS B.V.  
NL - Nijkerk  
Phone +31 33 247 20 30  
Fax: +31 33 246 15 99  
e-mail: netherlands@habasit.com  
www.rossi-group.com

### NEW ZEALAND

ROSSI GEARMOTORS NEW ZEALAND Ltd.  
NZ - Auckland  
Phone +61 9 263 4551  
fax +61 9 263 4557  
e-mail: info.nz@rossi-group.com  
www.rossigearmotors.com.au

### NORWAY

ROSSI GEARMOTORS SCANDINAVIA A/S  
DK - Frederiksberg  
Phone +47 38 11 22 42  
fax +47 38 11 22 58  
e-mail: info.denmark@rossi-group.com  
www.rossigearmotors.dk

### PORTUGAL

ROSSI MOTORREDUCTORES S.L.  
ES - Viladecans (Barcelona)  
Phone +34 93 6377248  
fax +34 93 6377404  
e-mail: info.spain@rossi-group.com  
www.rossimotoreductores.es

### SPAIN

ROSSI MOTORREDUCTORES S.L.  
ES - Viladecans (Barcelona)  
Phone +34 93 6377248  
fax +34 93 6377404  
e-mail: info.spain@rossi-group.com  
www.rossimotoreductores.es

### SWEDEN

ROSSI GEARMOTORS SCANDINAVIA A/S  
DK - Frederiksberg  
Phone +45 38 11 22 42  
fax +45 38 11 22 58  
e-mail: info.denmark@rossi-group.com  
www.rossigearmotors.dk

### SWITZERLAND

HABASIT AG  
CH - Reinach - Basel  
Phone +41 61 715 15 75  
fax +41 61 715 15 56  
e-mail: info.ch@habasit.com  
www.habasit.ch

### TAIWAN

HABASIT ROSSI (TAIWAN) LTD.  
TW - Taipei Hsien  
Phone +886 2 22670538  
fax +886 2 22670578  
e-mail: info.hea@habasit.com  
www.rossi-group.com

### UNITED KINGDOM

HABASIT ROSSI Limited  
UK - Coventry  
Phone +44 2476 644646  
fax +44 2476 644535  
e-mail: info.uk@habasitrossi.com  
www.habasitrossi.co.uk

### UNITED STATES

ROSSI GEARMOTORS  
A Division of Habasit America  
US - Suwanee  
Phone +1 800 931 2044  
fax +1 678 288 3658  
e-mail: rossi.info@us.habasit.com  
www.habasitamerica.com

#### Our Partner

Habasit is the worldwide market leader in the belting industry for power transmission, conveying and processing solutions



#### HABASIT AG

Römerstrasse 1  
CH - 4153 Reinach - Switzerland  
tel. +41 61 715 15 15  
fax +41 61 715 15 55  
e-mail: info@habasit.com  
www.habasit.com

#### Manufactured by

Rossi Motoriduttori S.p.A.  
Via Emilia Ovest 915/A  
41100 Modena - Italy  
Phone +39 059 33 02 88  
fax +39 059 82 77 74  
e-mail: info@rossi-group.com  
www.rossi-group.com

Registered trademarks  
Copyright Rossi Motoriduttori  
Subject to alterations  
Printed in Italy  
Publication data:  
4004BRO.GPR-de1105HQR  
4004BRO.GPR-en1105HQR

For worldwide sale and service network visit our websites [www.rossi-group.com](http://www.rossi-group.com) and [www.habasit.com](http://www.habasit.com)