

X10L



- ▶ Extra vacuum level to 93 -kPa
- ▶ Small size and low weight
- ▶ Use in tightly sealed or non-porous applications

Supplied with compressed-air hose connector.

TECHNICAL DATA

Description	Unit	Value
Feed pressure, max.	MPa	0.7
Noise level	dBA	62–66
Temperature range	°C	-20–80
Weight	g	30
Material		PA, POM, NBR, SS

VACUUM FLOW

Feed pressure MPa	Air consumption NI/s	Vacuum flow (NI/s) at different vacuum levels (-kPa)										Max vacuum -kPa
		0	10	20	30	40	50	60	70	80	90	
0.40	0.79	0.76	0.35	0.24	0.21	0.16	0.13	0.10	0.070	0.040	0.010	93

EVACUATION TIME

Feed pressure MPa	Air consumption NI/s	Evacuation time (s/l) to reach different vacuum levels (-kPa)									Max vacuum -kPa
		10	20	30	40	50	60	70	80	90	
0.40	0.79	0.11	0.47	0.94	1.5	2.2	3.1	4.3	6.6	14.0	93

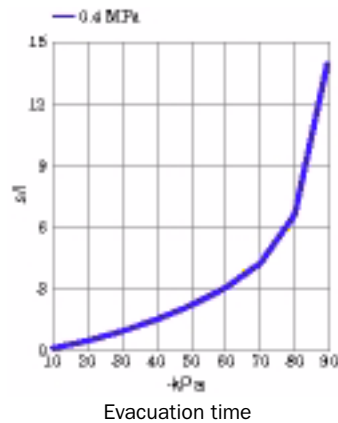
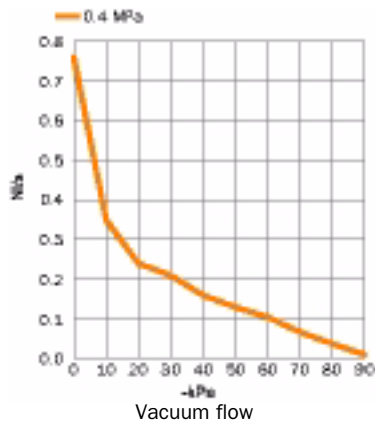

ORDERING INFORMATION

Description	Art. No.
Vacuum pump MINI X10L, conn. A, NBR sealings	3222157
Vacuum pump MINI X10L, conn. A, NBR sealings, non-return valve	3222157A

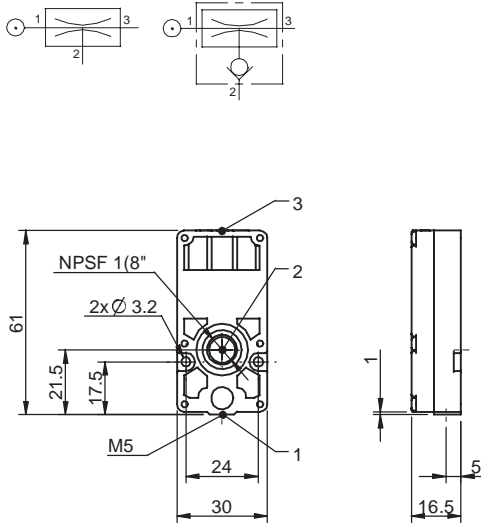

ORDERING INFORMATION, ACCESSORIES

Description	Art. No.
Sealing kit MINI 5-28, NBR	3201097
Sealing kit MINI 5-28, Viton®	3201097V
Sealing kit MINI 5-28, EPDM	3201097E

Sealing kits include flap valves, gaskets and compressed-air filters.

Vacuum pumps
MINI