

Digital electro pneumatic regulator EVD series



Compact high-function digital control

D sub-connector

Digital indicator

Operation key

Modular design

EVD-1000

- Port size: Rc1/4
- Flow rate: 400 ℓ /min.
- Pressure range: 500kpa
- Grease free flow path section

42

100

Large flow rate type

EVD-3000

- Port size: Rc1/4, Rc3/8
- Flow rate: 1500 ℓ /min.
- Pressure range: 500kpa

EVD Series

Digital electro pneumatic regulator

The easy-to-use highly functional compact EVD Series digital electropneumatic regulator features a variety of new functions including pressure display, error display, and direct memory.

User-friendly, outstanding installation performance

The digital display shows control status at a glance.

3-digit output pressure display
Output status (switch output ON-OFF) is displayed in addition to error display.

Output display 3-digit numerical LED display



Parallel input available as standard

Direct control is possible from the PLC.

Compact design is 25% smaller (CKD comparison)



The highly universal D-sub connector enables bidirectional connection.

The connection is rotated 90 degrees from top to side, enabling top or side connection to be selected based on use.



Modular design

Filters and regulators, such as the C1000 Series, are connectable.



Realizing high-level functions with microcomputer

Error display function

Errors are displayed and reported with electric signals.

Zero/span adjustment function

Zero and span can be adjusted according to the usage methods

Direct memory function

External input signals are not required.
Secondary pressure is adjusted as desired with operation keys.

Switch output function

Switch outputs (built-in overcurrent protection) is possible by setting the upper/lower limit pressure

Highly precise high-response pressure control

Linearity $\pm 0.3\%$

Hysteresis 0.5%

Response time 0.2sec

Environment-friendly design



No lead or polyvinyl chloride

All lead and polyvinyl chloride has been eliminated.

Energy saving

"Automatic power off" automatically turns off the digital display.

Material display

Materials are indicated on main components to facilitate recycling.

Digital electro pneumatic regulator variation

Series	Pressure range	Input signal	Port size	Output type	Maximum flow rate	Flow path material	Page
EVD-1000	500 kpa	Analog output Parallel	Rc1/4	NPN PNP Switch output Analog output	400 ℓ /min	Grease free	1
EVD-3000	500 kpa	Analog Parallel	Rc1/4 Rc3/8	NPN PNP Switch output Analog output	1500 ℓ /min	Fluorine grease Vaseline (Custom order)	5

Example of proportional pressure controls

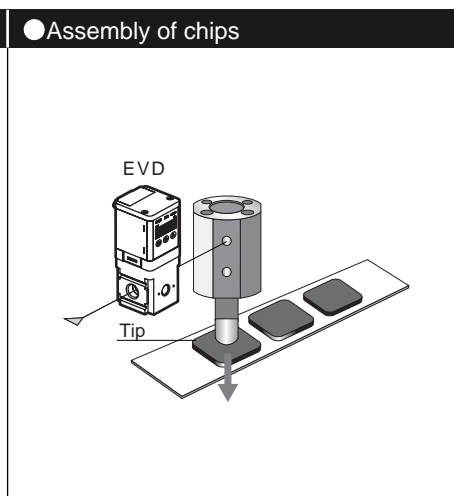
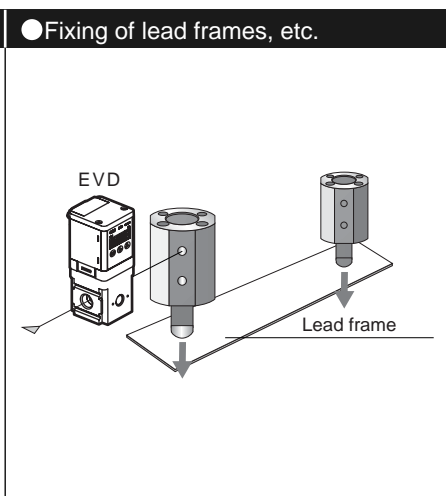
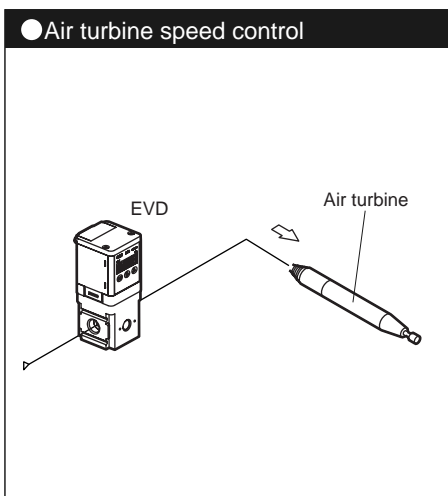
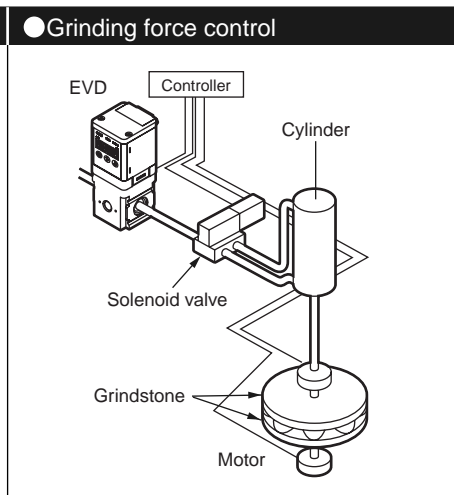
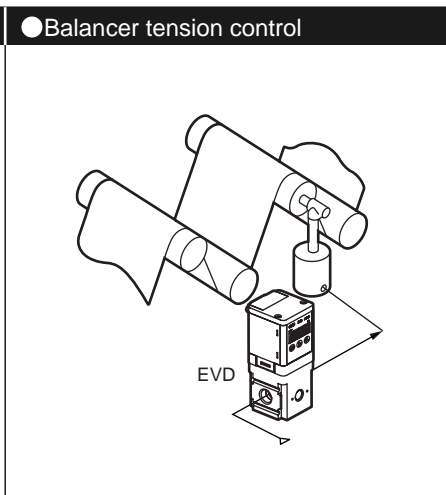
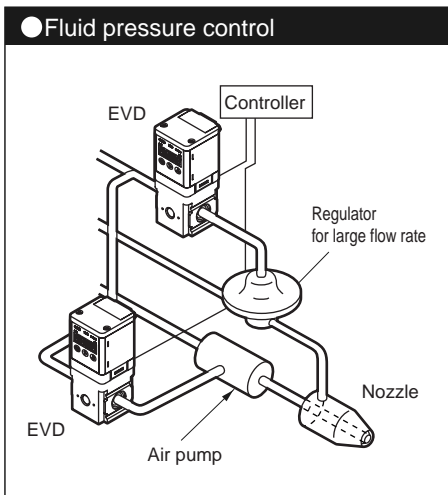
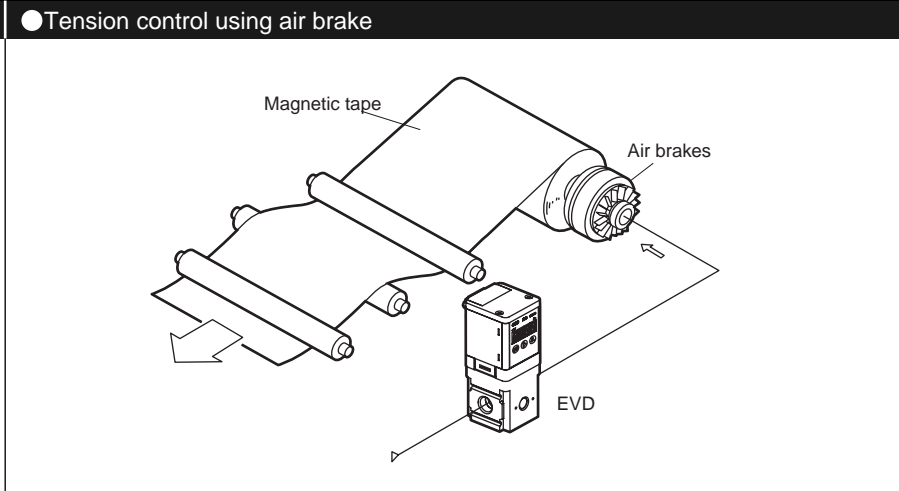
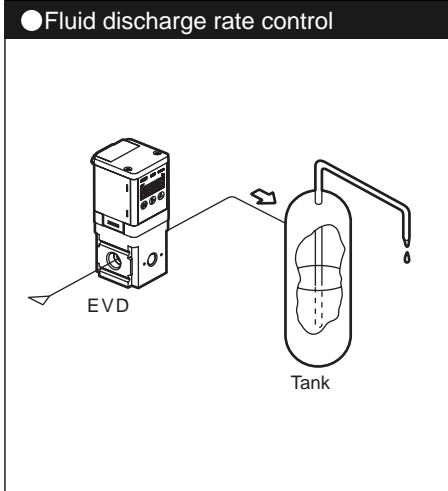



Safety Precautions

Always read before starting use

When designing and manufacturing a device using CKD products, the manufacturer is obligated to check that device safety mechanical mechanism, pneumatic control circuit, or water control circuit and the system operated by electrical control that controls the devices is secured.

It is important to select, use, handle, and maintain the product appropriately to ensure that the CKD product is used safely.

Observe warnings and precautions to ensure device safety.

Check that device safety is ensured, and manufacture a safe device.

WARNING

1 This product is designed and manufactured as a general industrial machine part. It must be handled by an operator having sufficient knowledge and experience in handling.

2 Use this product in accordance of specifications.

Contact CKD when using the product outside the unique specifications range, when using it outdoors, and when using it under the conditions and environment below. Do not attempt to modify or additionally machine the product.

- ① Use for special applications requiring safety including nuclear energy, railroad, aviation, ship, vehicle, medical equipment, equipment, or applications coming into contact with beverage or food, amusement equipment, emergency shutoff circuits, press machine, brake circuits, or for safeguard.
- ② Use for applications where life or assets could be adversely affected, and special safety measures are required.

3 Observe corporate standards and regulations, etc., related to the safety of device design and control, etc.

ISO 4414, JIS B 8370 (pneumatic system rules), JIS B 8368 (pneumatic cylinder), JPAS 005 (principles for pneumatic cylinder use and selection), High Pressure Gas Maintenance Laws Occupational Safety and Sanitation Laws, and other safety regulations, corporate standards, and regulations.

4 Do not handle, pipe, or remove devices before confirming safety.

- ① Inspect and service the machine and devices after confirming safety of the entire system related to this product.
- ② Note that there may be hot or charged sections even after operation is stopped.
- ③ When inspecting or servicing the device, turn off the energy source (air supply or water supply), and turn off power to the facility. Discharge any compressed air from the system, and pay enough attention to possible water leakage and leakage of electricity.
- ④ When starting or restarting a machine or device that incorporates pneumatic components, make sure that the system safety, such as pop-out prevention measures, is secured.

5 Observe warnings and cautions on the pages below to prevent accidents.

■ The safety cautions are ranked as "DANGER", "WARNING" and "CAUTION" in this section.

 **DANGER:** When a dangerous situation may occur if handling is mistaken leading to fatal or serious injuries, or when there is a high degree of emergency to a warning.

(DANGER)

 **WARNING:** When a dangerous situation may occur if handling is mistaken leading to fatal or serious injuries.

(WARNING)

 **CAUTION:** When a dangerous situation may occur if handling is mistaken leading to minor injuries or physical damage.

(CAUTION)

Note that some items described as "CAUTION" may lead to serious results depending on the situation.

In any case, important information that must be observed is explained.



Safety precautions

Always read this section before starting use.

Design & Selection

⚠ WARNING

■ Thoroughly understand the characteristics of compressed air before designing the pneumatic circuit.

- The same functions as mechanical, hydraulic, or electrical methods cannot be anticipated if instantaneous stop holding is required during an emergency stop.
- Pop-out, air discharge, and leakage are caused by compression and expansion of air characteristics.

■ Confirm that the product will withstand the working environment.

- This product cannot be used in an environment containing corrosive gas, chemical liquids, solvents, water, vapor, or ozone. If water drip, oil or metal chips (spatter or cutting chips, etc.) could come in contact with the product, provide appropriate guarding.
- This product cannot be used in the environment containing flammable gas.

■ Take care of electrical circuits during emergency stops and cylinder operation during a service interruption.

■ Install a "pressure switch" and "shut-off valve" on the device's compressed air inlet.

- The pressure switch will disable operation until set pressure is reached. The shut-off valve will exhaust compressed air in the pneumatic pressure circuit, and will prevent accidents caused by operation of pneumatic components by residual pressure.

■ If the regulator is left with power off and primary pressure applied, secondary pressure may rise to the primary level. Due to the structure, a small amount of air is consumed from the EXH port when secondary pressure is generated.

Set the primary regulator to 0 or use a valve on the primary side to shut off the supply source when not using the regulator.

⚠ CAUTION

■ Indicate the maintenance conditions in the device's instruction manual.

- The product's function can drop markedly with working status, working environment, and maintenance, and can prevent safety from being attained. With correct maintenance, the product functions can be used to the fullest.

■ Confirm that power used is constant voltage.

■ Check leakage current to prevent the product from malfunctioning due to leakage current from other controls.

- When using a programmable controller, etc., leakage current could cause the electro pneumatic regulator to malfunction.

For 24 VDC	1.8mA or less
------------	---------------

■ Response is affected by the working pressure and load volume. If repeatability with stable response is required, install a regulator before the product.

■ Do as follows to prevent malfunction due to noise.

- Insert a line filter in the AC power supply line.
- Use a surge suppressor, such as a CR or diode on the conductive load (solenoid valve, relay, etc.), and remove noise where generated.
- Keep wiring to the device separate from strong magnetic fields.
- Connect wiring to the device with a shield wire.
- Ground the shield wire on the power supply.
- Keep the power cable as short as possible.
- Do not share power with noise-generating devices such as inverters or motors.
- Do not lay power, signal, or other power cables in parallel.

■ Due to wiring, power ground and signal common are the same for the current input type.

- When driving several electropneumatic regulators with 1 PLC and D/A, the D/A's circuitry could prevent the correct signal from being input. Check with the PLC maker.

■ Current input is used with a 1-5 V input signal but impedance is less than other voltage input (250Ω). Use an appropriate signal generator.

■ Poor air quality adversely affects function and life.

- For the pneumatic pressure source, supply air free of solids, moisture, and oil using a dryer, air filter, or oil mist filter. Air containing oil could adversely affect function.

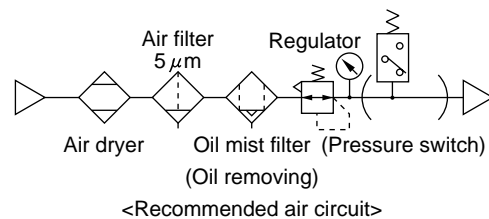

- When secondary pressure is lowered by an input signal, etc., secondary air passes through and is discharged from the EXH port. Contamination of secondary piping and internal load adversely affects function, so piping should be kept as clean inside as possible.

■ If power is turned off during pressurization, secondary pressure is maintained.

- To set exhaust, lower the set pressure with the input signal before turning power off or exhaust with a shutoff valve. There is no guarantee that this held state can be maintained for a long time.

Design & Selection

⚠ CAUTION

- Confirm that primary pressure does not drop to less than "set secondary pressure + maximum control pressure x 0.2."
 - Regulator life is shortened if primary pressure is not supplied for a long time while power is on. Avoid such use.
- When releasing secondary control pressure, such as air exhaust, into the atmosphere, pressure may fluctuate depending on piping and other conditions. Test under actual working conditions, or consult with CKD before doing this.
- Select a dryer, air filter, oil mist filter, or regulator with a flow higher than that of this regulator.

■ Work environment

Avoid using this regulator where it will be subject to direct sunlight, water or oil, etc. Consult with CKD when using outside designated specifications or for special applications.

■ Dripproof environment

The regulator's protective structure is equivalent to IP40. Do not install it where water, salt, dust, or cutting chips are present or under pressurized or de-pressurized conditions. Use at sites of drastic temperature changes or high humidity may cause damage due to dew condensation in the regulator.

- Even when set to 0 MPa, secondary pressure remains within 5 kPa or less. If 0 MPa is required, bleed the secondary side or install a 3-way valve on the secondary side to change to atmosphere, etc.

Installation & Adjustment

⚠ DANGER

Installation

- Set power voltage and output to the specified voltage. Using a voltage exceeding that specified could result in malfunction, controller damage, electric shock, or fire. Do not use a load exceeding the output rating. Failure to observe this may result in output damage or fire.

⚠ WARNING

Wiring

- Connector pin and cables conductors color must be checked when wiring. Check wire color with handling precaution, since improper wire connection leads to destruction/failure and malfunction.
- Insulation of wiring must be checked. Contact to another circuit, ground fault or terminal insulation defective must be eliminated. Overcurrent may be admitted to damage.
- Use DC safety power supply in rated, insulated from alternating current power, for this product. If power supply is not insulated, electric shock may result. If power supply is not stabilized, peak magnitude exceeds rated, and damages this product, worsening accuracy.
- Stop controllers and machinery and turn power off before wiring. Starting operation immediately after wiring could result in unpredictable operation and hazard. Conduct energized tests with controllers and machinery stopped. Before starting work, remove static electricity in personnel, tools, and devices. Use

flexible wires, such as robot wires, for connection at movable sections.

- Do not use power voltage exceeding specifications. The regulator could rupture or catch fire if voltage exceeding the working range is applied or if 100 VAC power is applied.
- Short-circuiting the load could result in rupture or fire.

⚠ CAUTION

Installation

- Secure sufficient peripheral space for operating, installing, removing, wiring, and piping the product.
- Install the air filter just before the circuit using the pneumatic component.
- Install the regulator so that the exhaust port is not blocked, and secure a space required for exhaust.

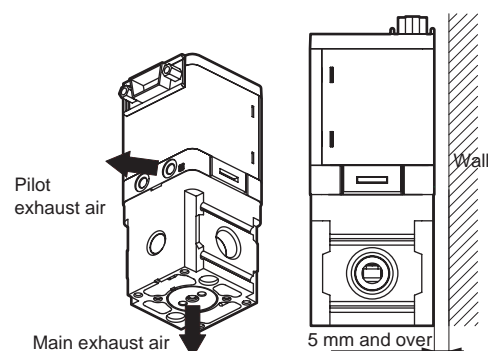

Installation & Adjustment

- The D-sub connector's rotator is not designed for use in moving applications. Use it at the top or side and without tilt. Fix the cable if it may move.

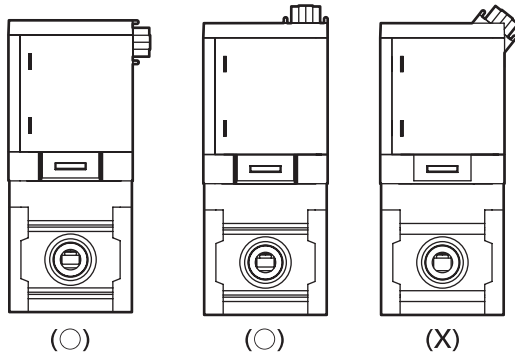

⚠ CAUTION

Piping

- Do not remove the port seal until just before piping the regulator.
 - Removing the port seal from the piping port before piping is started could let foreign matter enter from the piping port and result in faults or faulty operation.
- Sufficiently flush pneumatic pipes before connecting. Confirm that sealing tape does not enter piping.
- When connecting pipes, wrap sealing tape in the opposite direction from threads starting 2 mm margin from the end of piping threads.
 - If sealing tape protrudes from pipe threads, it could be cut when screwed in. This could cause the tape to enter the pneumatic components and lead to faults.

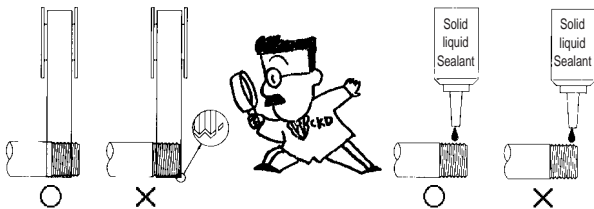

Wiring

- The optional shield cable connector is a shielded wire.
 - Insulate unused wires so they do not contact other wires, including shielded wires. Inadvertent connection to ground, etc., could result in malfunction or regulator damage.
- Securely insert and fit the D-sub connector to the back.

- The D-sub connector rotates 90 degrees. When fitting the D-sub connector, press it in by hand so that it faces the top or side.

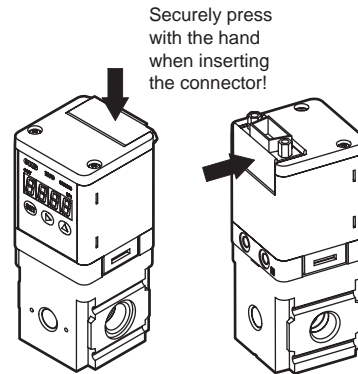

- Proper pressure control is not possible if the exhaust port is plugged. Release into the atmosphere.
- Tighten pipes with the appropriate torque.
 - Pipes must be connected with the appropriate torque to prevent air leakages and screw damage.
 - First tighten the screw by hand to prevent damage to screw threads, then use a tool.

[Recommended tightening torque]

Set screw	Tightening torque N·m
Rc1/4	6 to 8
Rc3/8	13 to 15

- When supplying compressed air for the first time after connecting pipes, do not apply high pressure suddenly.
- When supplying compressed air for the first time after connecting pipes, confirm that no air is leaking from any pipe connections.
 - Apply a leakage detection agent on pipe connections with a brush, and check for air leaks.
- Lock the D-sub connector so that it does not move. Fix the fixed bed with a tool, etc., when releasing the screw lock.

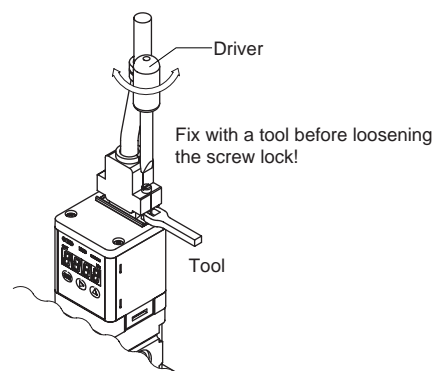

During use & Maintenance

⚠ WARNING

- Do not supply other than compressed air.
- Use clean compressed air that does not contain corrosive gas.
- Use "ISO Class 1.3.2" clean dry air from which oil has been removed.
- Before servicing the product, turn power OFF, stop the compressed air supply, and check that there is no residual pressure.
 - This is a requirement for ensuring safety.

⚠ CAUTION

- Plan daily inspections and periodic inspections to ensure that maintenance is correctly controlled.
 - If maintenance is not correctly controlled, the product's functions could drop markedly and lead to a shortened life, damage, malfunctions, faults, and accidents.
1. Control of supplied compressed air pressure
 - Is the set pressure supplied? Does the pressure gauge indicate the set pressure during operation of the device?

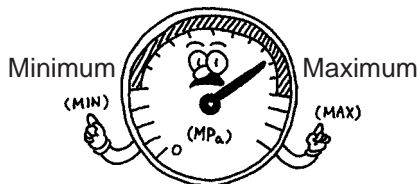

2. Control of air filter
 - Is the drain correctly discharged?
Is the bowl or element dirty?
3. Control of compressed air leaks from piping connections
 - Is the state of the connection, especially at movable sections, normal?
Operation may be abnormal if pipes leak.
4. Control of operation
 - Are any operations delayed? Is exhaust normal?
5. Control of pneumatic actuator operation
 - Is operation smooth? Is end stop normal?
Is coupling with the load normal?

- If an abnormality occurs during operation, turn power and air pressure off immediately and stop use.
- Use this regulator within the working pressure range.
- This regulator does not start pressure control for about 2 seconds after power is turned on so it can complete self-diagnostics. Provide a control circuit and program that ignores signals for about 2 seconds after power is turned on.
- When the output setting is changed, controllers could operate accidentally. Stop devices before changing settings.
- Regularly inspect the regulator at least once a year and confirm that it is operating correctly.
- This case is made of resin. Do not use solvent, alcohol, or detergent when cleaning because resin could be damaged. Wipe off dirt with a rag dampened in a diluted neutral detergent solution.

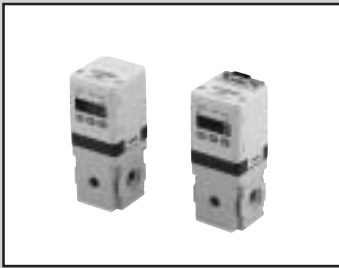

Digital electro pneumatic regulator

EVD-1000 Series

JIS symbol

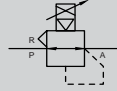

Specifications

Descriptions	EVD-1500-□08□		EVD-1500-P08□	
	Analog type		Parallel type	
Working fluid	Clean compressed air			
Max. working pressure	700kPa			
Mini. working pressure (kPa)	Set pressure+maximum control pressure X 0.2			
Withstanding pressure	Inlet side	1050 kPa		
	Output side	750 kPa		
Control pressure range	0 to 500 kPa			
Power supply voltage	24 VDC \pm 10% (stabilized power supply with ripple rate of 1% or less)			
Current consumption	0.15 A or less (0.6 A rush current when power is turned on)			
Input signal (Input impedance)	0 to 10 VDC (6.7k Ω)		10bit	
	0 to 5 VDC (10k Ω)			
	4 to 20 mADC (250 Ω)			
Preset input	8 points		None	
Output signal	Note 1	Analog output: 1-5 VDC (connected load impedance of 500 k Ω and over)		
		Switch output: NPN or PNP open collector output, 30 V or less, 50 mA or less, voltage drop of 2.4 V or less, PLC and relay compatible		
Error output signal	NPN or PNP open collector output, 30 V or less, 50 mA or less, voltage drop of 2.4 V or less, PLC and relay compatible			
Direct memory setting	5 to 500 kPa (minimum setting width 1 kPa)			
Hysteresis	Note 2	0.5% F.S. or less		
Linearity	Note 2	\pm 0.3% F.S. or less		
Resolution	Note 2	0.2% F.S. or less		
Repeatability	Note 2	0.3% F.S. or less		
Temperature characteristics	Zero point fluctuation		0.15% F.S./ $^{\circ}$ C or less	
	Span point fluctuation		0.07% F.S./ $^{\circ}$ C or less	
Max. flow rate (ANR)	Note 3	400 ℓ /min		
Step response time	Note 4	0.2sec. or less (loadless)		
Mechanical vibration proof	98 m/s ² or less			
Ambient temperature	5 to 50 $^{\circ}$ C			
Working fluid temperature	5 to 50 $^{\circ}$ C			
Port size	Rc1/4			
Installation attitude	Free			
Mass	250g			
Protective circuit	Power supply reverse connection prevention, switch output reverse connection protection, switch output load short-circuit protection			

Note 1: Select either analog or switch output.

Note 2: The above applies in control pressure 10 to 90 % with 24 VDC power voltage and working pressure set at the maximum control pressure \times 1.2 (=0.6 MPa). Pressure may fluctuate if used for applications such as blowing only when the secondary side is a closed circuit.

Note 3: The above apply when working pressure and control pressure are maximum.

Note 4: The above apply when working pressure is maximum and the step is as follows:

{	50% F.S. -> 100% F.S.
	50% F.S. -> 60% F.S.
	50% F.S. -> 40% F.S.

How to order

EVD-1 **500** - **0** **08** **AN** - **C1B1** - **3**

A Pressure specifications

B Input specifications

C Port size

D Output specifications

E Option

F Power supply voltage

● Option (cable, bracket) part model No.

EVD- **C1**

E Option

Symbol	Descriptions
A Pressure specifications	
500	500 kPa
B Input specifications	
0	0-10 VDC
1	0-5 VDC
2	4-20 mADC
P	Parallel 10bit
C Port size	
08	Rc1/4
D Output specifications	
AN	1-5V analog, error (NPN)
AP	1-5V analog, error (PNP)
SN	Switch (NPN), error (NPN)
SP	Switch (PNP), error (PNP)
E Option	
Cable option	
Blank	None
C1	Analog 9-conductor cable, 1 m
C3	Analog 9-conductor cable, 3 m
P1	Parallel 15-conductor cable, 1 m
P3	Parallel 15-conductor cable, 3 m
Bracket option	
Blank	None
B1	B type bracket, floor installation type
L1	L type bracket, wall installation type
F Power supply voltage	
3	24VDC

Internal structure and parts list

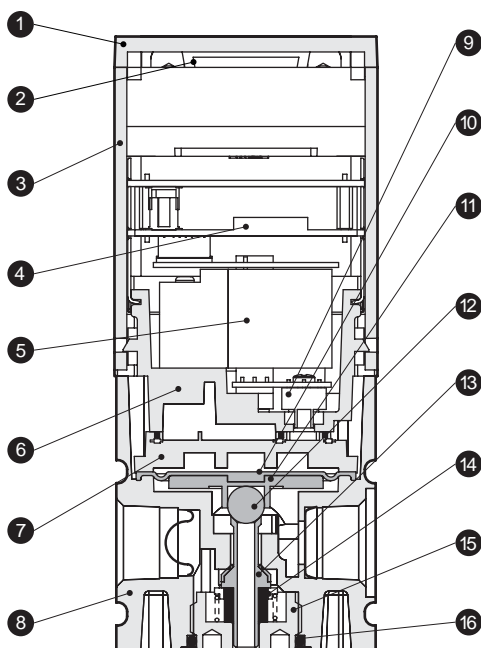

No.	Parts name	Material
1	Cover	PBT resin
2	D sub-connector	-
3	Housing	ABS resin
4	Controller circuit board	-
5	3 way valve	-
6	Valve base	Polyphenylen sulfite resin
7	Pilot chamber	Polyphenylen sulfite resin
8	Body	Aluminum alloy die casting
9	Pressure sensor	-
10	Diaphragm	Special nitrile rubber
11	Relief sheet	Aluminum alloy
12	Steel ball (exhaust valve)	SUJ
13	Valve	Special nitrile rubber and stainless steel
14	Bottom rubber	Silicon rubber
15	Bottom plug	Brass and electroless nickeling
16	O ring	Fluoro rubber

I/O characteristics

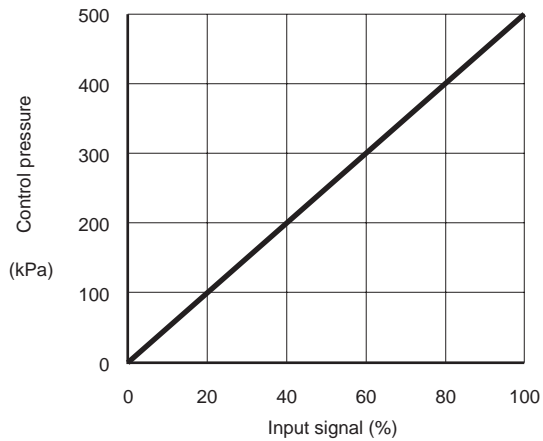

Flow characteristics

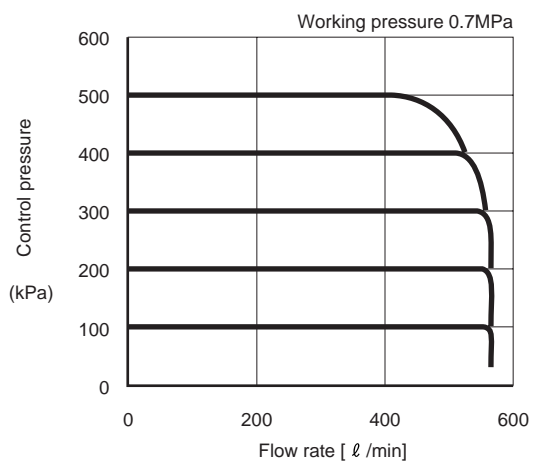

Relief characteristics

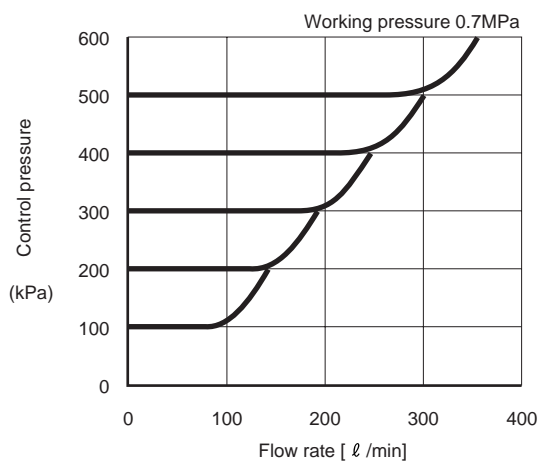

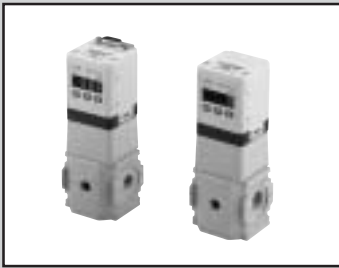

Digital electro pneumatic regulator

EVD-3000 Series

JIS symbol

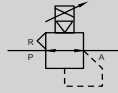

Specifications

Descriptions	EVD-3500-□08□ EVD-3500-□10□		EVD-3500-P08□ EVD-3500-P10□	
	Analog type		Parallel type	
Working fluid	Clean compressed air			
Max. working pressure	700 kPa			
Min. working pressure (kPa)	Set pressure+maximum control pressure X 0.2			
Withstanding pressure	Inlet side	1050 kPa		
	Output side	750kPa		
Control pressure range	0 to 500 kPa			
Power supply voltage	24 VDC ±10% (stabilized power supply with ripple rate of 1% or less)			
Current consumption	0.15 A or less (0.6 A rush current when power turned on)			
Input signal (Input impedance)	0 to 10 VDC (6.7kΩ)		10bit	
	0 to 5 VDC (10kΩ)			
	4 to 20 mADC (250Ω)			
Preset input	8 points		None	
Output signal	Note 1	Analog output: 1-5 VDC (connected load impedance of 500 kΩ and over)		
Error output signal		Switch output: NPN or PNP open collector output, 50 mA or less, voltage drop of 2.4 V or less, PLC and relay compatible		
Direct memory setting		NPN or PNP open collector output, 50 mA or less, voltage drop of 2.4 V or less, PLC and relay compatible		
Hysteresis	Note 2	5 to 500 kPa (setting minimum width 1kPa)		
Linearity	Note 2	0.5% F.S. or less		
Resolution	Note 2	±0.3% F.S. or less		
Repeatability	Note 2	0.2% F.S. or less		
Temperature characteristics	Zero point fluctuation	0.3% F.S. or less		
	Span point fluctuation	0.07% F.S./°C or less		
Max. flow rate (ANR)	Note 3	1500 ℓ/min		
Step response time	Note 4	0.2sec. or less (loadless)		
Mechanical vibration proof		98m/s ² or less		
Ambient temperature		5 to 50 °C		
Working fluid temperature		5 to 50 °C		
Port size		Rc1/4, Rc3/8		
Installation attitude		Free		
Mass		450g		
Protective circuit		Power supply reverse connection prevention, switch output reverse connection protection, switch output load short-circuit protection		

Note 1: Select either analog or switch output.

Note 2: The above applies in control pressure 10 to 90 % with 24 VDC power voltage and working pressure set at the maximum control pressure×1.2 (=0.6 MPa).
Pressure may fluctuate if used for applications such as blowing only when the secondary side is a closed circuit.

Note 3: The above apply when working pressure and control pressure are maximum.

Note 4: The above apply when working pressure is maximum and the step is as follows:

50% F.S. ->	100% F.S.
50% F.S. ->	60% F.S.
50% F.S. ->	40% F.S.

How to order

EVD-3 **500** - **0** **08** **AN** - **C1B3** - **3**

A Pressure specifications

B Input specifications

C Port size (IN, OUT)

D Output specifications

E Option

F Power supply voltage

● Option (cable, bracket) part model No.

EVD- **C1**

E Option

Symbol	Descriptions
A Pressure specifications	
500	500 kPa
B Input specifications	
0	0 to 10 VDC
1	0 to 5 VDC
2	4 to 20 mA DC
P	Parallel 10bit
C Port size (IN, OUT)	
08	Rc1/4
10	Rc3/8
D Output specifications	
AN	1 to 5 V analog, error (NPN)
AP	1 to 5 V analog, error (PNP)
SN	Switch (NPN), error (NPN)
SP	Switch (PNP), error (PNP)
E Option	
Cable option	
Blank	None
C1	Analog 9-conductor cable, 1 m
C3	Analog 9-conductor cable, 3 m
P1	Parallel 15-conductor cable, 1 m
P3	Parallel 15-conductor cable, 3 m
Bracket option	
Blank	None
B3	B type bracket, floor installation type
L3	L type bracket, wall installation type
F Power supply voltage	
3	24VDC

Internal structure and parts list

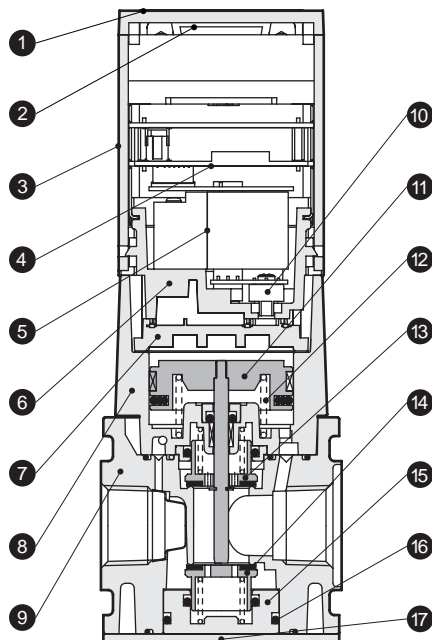

No.	Parts name	Material
1	Cover	PBT resin
2	D sub-connector	-
3	Housing	ABS resin
4	Controller circuit board	-
5	3 way valve	-
6	Valve base	Polyphenylen sulfite resin
7	Pilot chamber	Polyphenylen sulfite resin
8	Piston body assembly	Aluminum alloy die casting, etc.
9	Body	Aluminum alloy die casting
10	Pressure sensor	-
11	Piston assembly	Aluminum alloy and stainless steel, etc.
12	Spring	Stainless steel
13	Top valve	Special brass and nitrile rubber
14	Bottom valve	Special brass and nitrile rubber
15	Bottom cap	Brass
16	O ring	Nitrile rubber
17	Base plate	Steel sheet

EVD-3000 Series

Dimensions

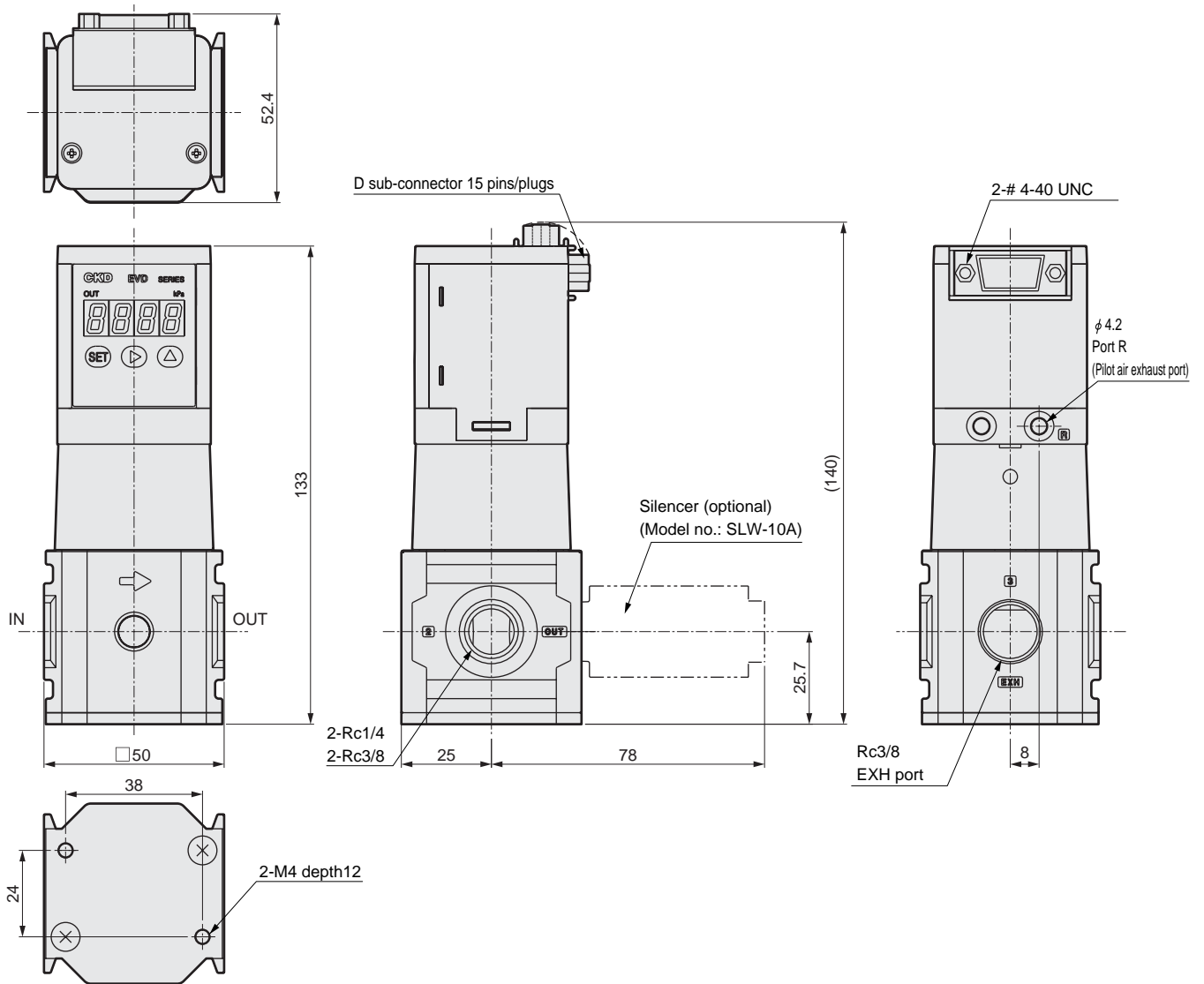

Option dimensions

● B type bracket (-B3): floor installation type

● L type bracket (-L3): wall installation type

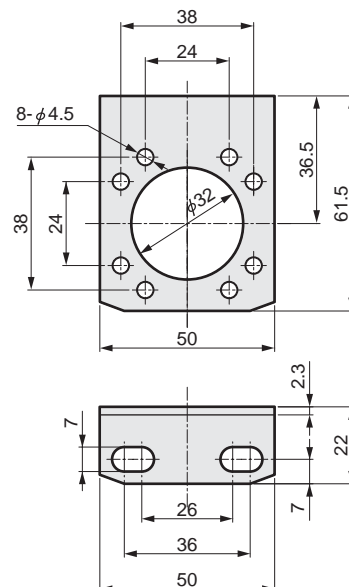
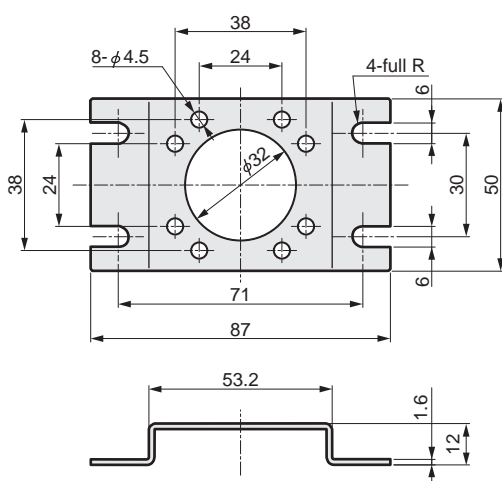

*Refer to Page 9 for cable option dimensions.

I/O characteristics

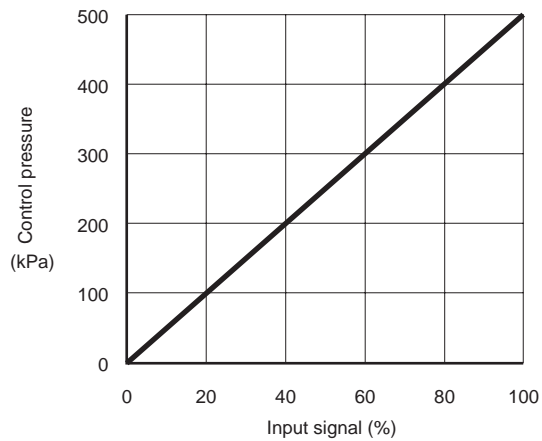

Flow characteristics

● EVD-3500-□08

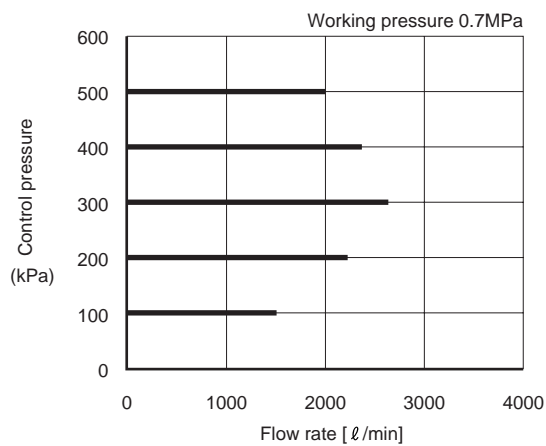

● EVD-3500-□10

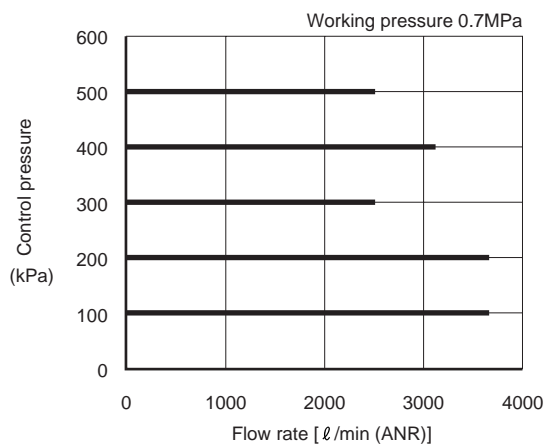

Relief characteristics

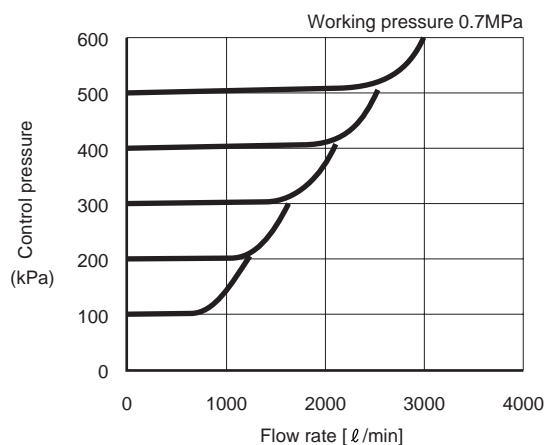

Cable option dimensions

●EVD-C1, EVD-C3

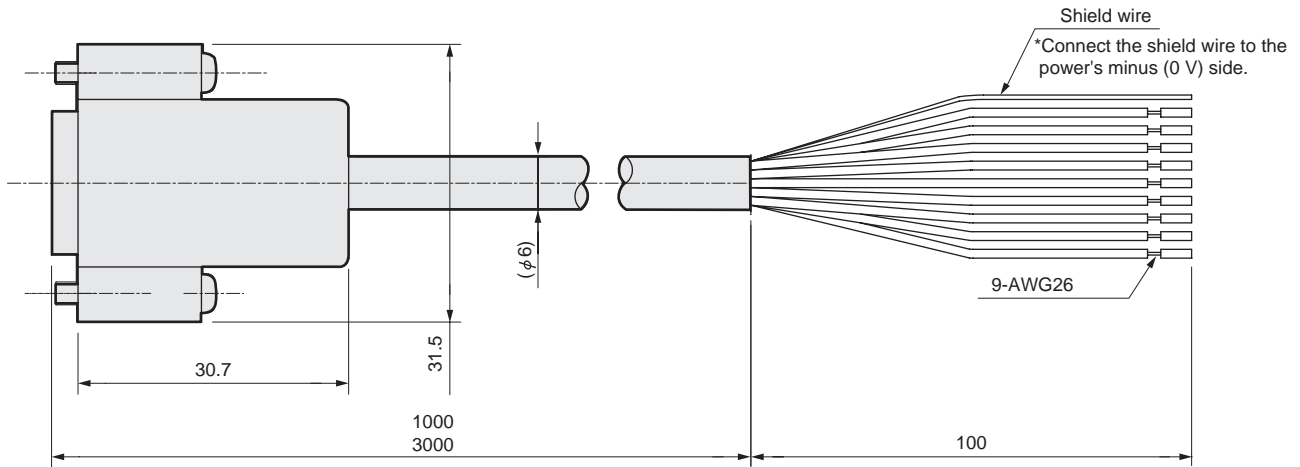

D sub socket pin no.	1	2	3	4	5	6	7	8	9	10	11	12	13	14	15			
Isolator color	Brown	Orange	Yellow	-	Red	-	-	-	-	Gray	White	-	Green	Blue	Black			
Name	Preset input signal				Power supply+						Input signal	Vacant	Monitor output	Switch output	Error output			
Type of input	Bit 1	Bit 1	Bit 1	Vacant	+24VDC	Vacant	Vacant	Vacant	Vacant	Common	0 to 10 VDC	0 to 5 VDC	4 to 20 mADC	Vacant	Output short-circuit protection circuit 1 to 5 VDC	NPN or PNP output	NPN or PNP output	Power supply- (0V)

●EVD-P1, EVD-P3

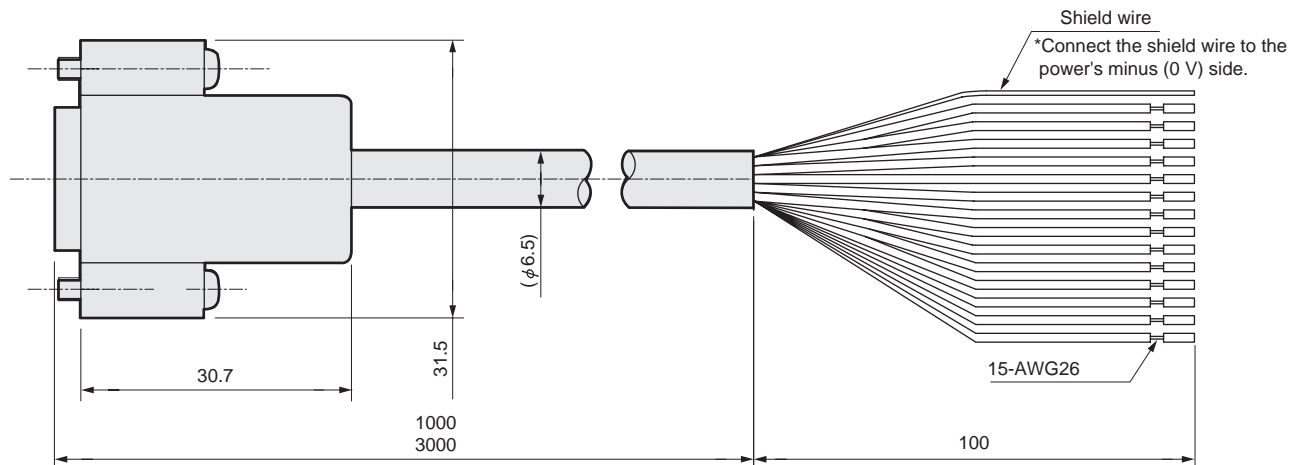

D sub Socket Pin no.	1	2	3	4	5	6	7	8	9	10	11	12	13	14	15	
Isolator color	Brown	Orange	Yellow	Purple	Red	Light blue	Pink	White (with a black line)	Red (with a black line)	Gray	White	Green (with a black line)	Green	Blue	Black	
Name	Parallel input signal				Power supply+	Parallel input signal					Parallel input signal	Monitor output	Switch output	Error output		
Type of input	Bit 1	Bit 2	Bit 3	Bit 4	+24VDC	Bit 5	Bit 6	Bit 7	Bit 8	Common	Bit 9	Bit 10	Output short-circuit protection circuit 1 to 5 VDC	NPN or PNP output	NPN or PNP output	Power supply- (0V)

MEMO

Example of internal circuit and load connection for analog input

EVD-1□-0□AN-□-□, EVD-1□-1□AN-□, EVD-1□-2□AN-□
 EVD-3□-0□AN-□-□, EVD-3□-1□AN-□, EVD-3□-2□AN-□
 (Analog input, analog output + error output type, NPN output)

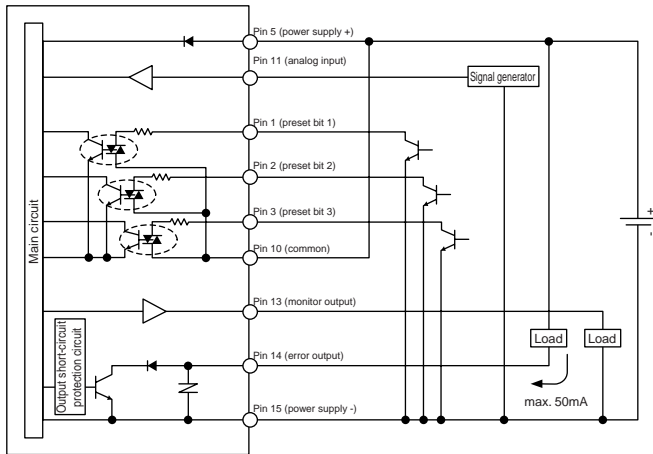

EVD-1□-0□AP-□-□, EVD-1□-1□AP-□, EVD-1□-2□AP-□
 EVD-3□-0□AP-□-□, EVD-3□-1□AP-□, EVD-3□-2□AP-□
 (Analog input, analog output + error output type, PNP output)

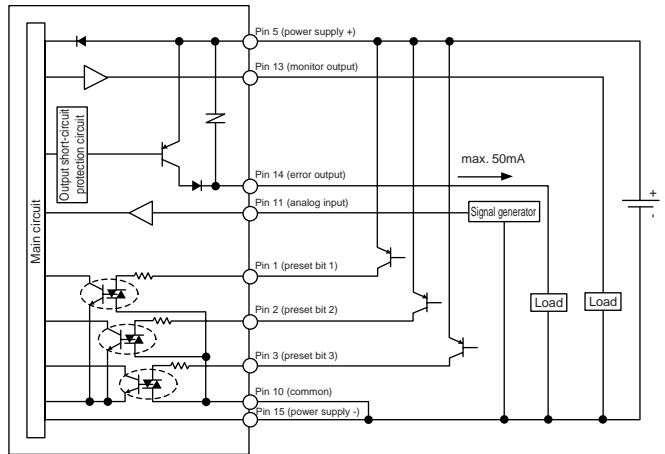

EVD-1□-0□SN-□-□, EVD-1□-1□SN-□, EVD-1□-2□SN-□
 EVD-3□-0□SN-□-□, EVD-3□-1□SN-□, EVD-3□-2□SN-□
 (Analog input, switch output + error output type, NPN output)

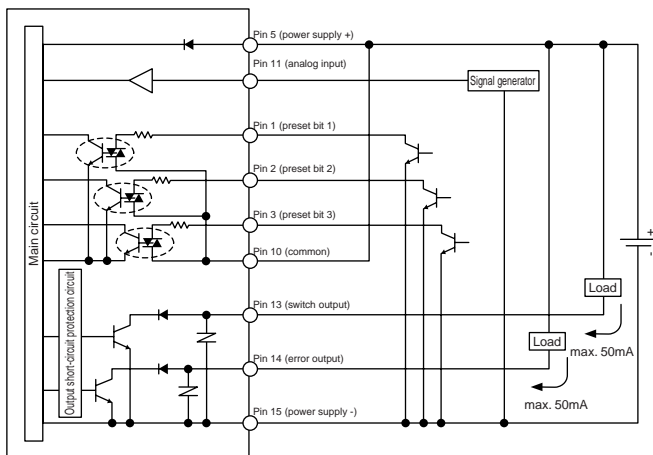

EVD-1□-0□SP-□-□, EVD-1□-1□SP-□, EVD-1□-2□SP-□
 EVD-3□-0□SP-□-□, EVD-3□-1□SP-□, EVD-3□-2□SP-□
 (Analog input, switch output + error output type, PNP output)

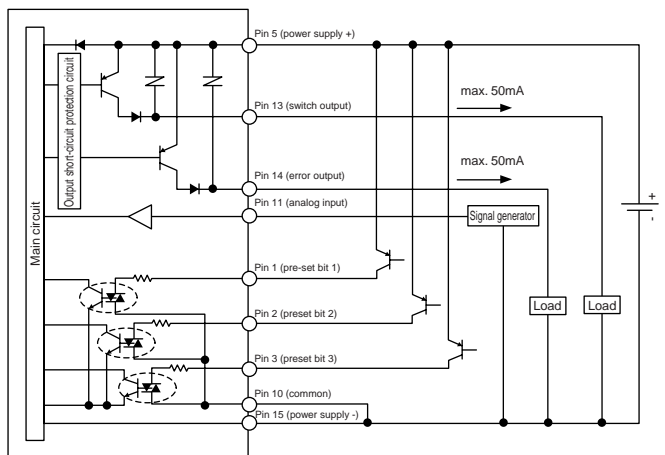

■ Connector pin layout (product body side)

[Analog input type]

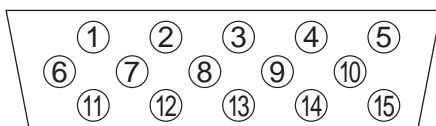

Analog input does not have ④, ⑥, ⑦, ⑧, ⑨ or ⑫ pins.

Example of internal circuit and load connection for parallel input

EVD-1□-P□AN-□-□
EVD-3□-P□AN-□-□
(Parallel input, analog output + error output type, NPN output)

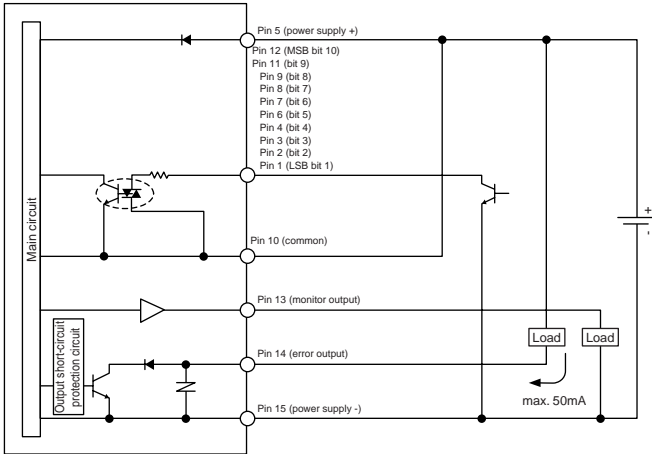

EVD-1□-P□AP-□-□
EVD-3□-P□AP-□-□
(Parallel input, analog output + error output type, PNP output)

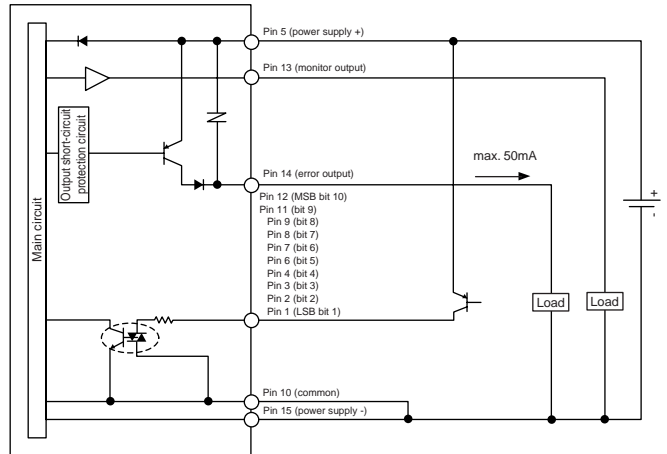

EVD-1□-P□SN-□-□
EVD-3□-P□SN-□-□
(Parallel input, switch output + error output type, NPN output)

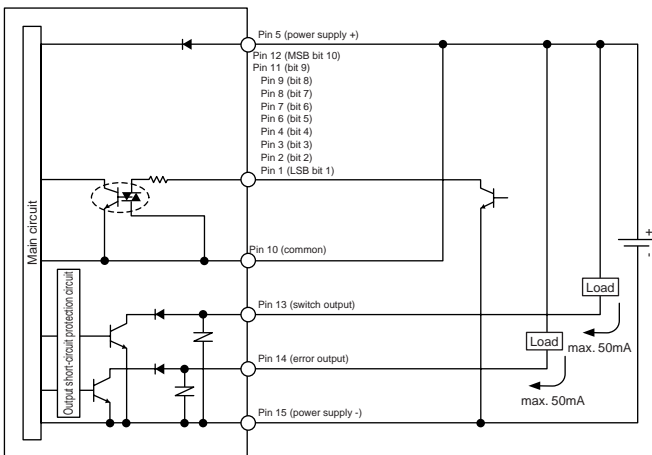

EVD-1□-P□SP-□-□
EVD-3□-P□SP-□-□
(Parallel input, switch output + error output type, PNP output)

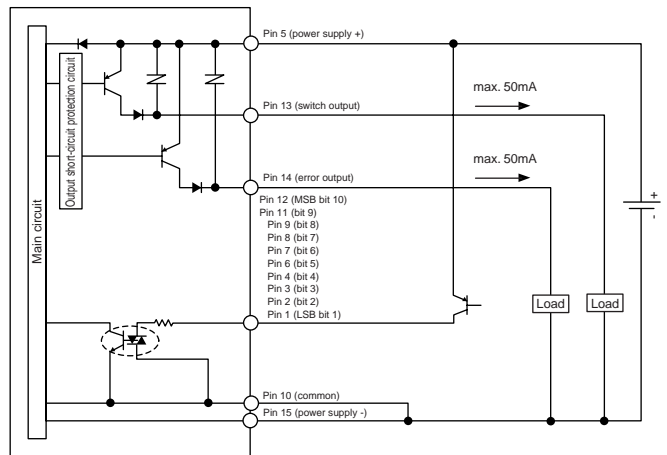

■ Connector pin layout (product body side)
[Parallel input type]

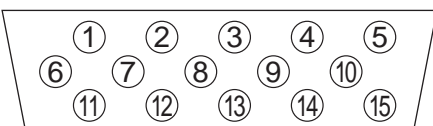

Names and functions of display and operation sections

Output display (red)

● "F" is displayed when confirming function setting.

● "-" lights when the switch output is on.
(Only when using switch output specifications)
*Blinks when overcurrent is detected.

● "E" lights when error output is on.
*Blinks when overcurrent is detected.

*If there is a +/- or upper/lower limit to the function setting,
 or is displayed.

SET Key

- Use to enter setting modes
- Use to set values, etc., when entering data.

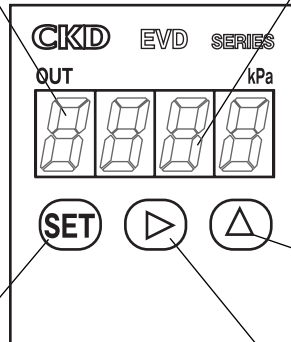

3-digit numerical LED display (green)

- Displays pressure and function setting details during RUN mode (pressure display).
*The set mode No. and set details are displayed when function setting details are displayed.
- The value, etc., is displayed when setting data.
- The error code No. is displayed when an error is output.

<Pressure display> <Set details display> <Error output>

Setting mode Setting number Setting method Code no.

△ Key

- Setting details are sequentially displayed during RUN mode (pressure display).
- Use to select the setting item when setting data.
- Use to count up the value, etc., when setting data.

▶ Key

- Use to select the digit of the value, etc., when setting data.

Function list

Screen display	Name	Display descriptions (RUN mode)	Setting descriptions (setting mode)	Setting method
	Pressure display	Secondary pressure is confirmed with the 3-digit numerical display LED. Unit: kPa		
 Screen F1 	Input signal selection	The selected input signal and current target value (pressure conversion value) are confirmed. *When preset input (8-point) is selected, the currently selected preset No. and setting are displayed.	For analog input type: analog input, preset memory input, or direct memory input is selected. For preset input/direct memory input, input the setting for this mode. For parallel input: parallel input or direct memory input is selected. For direct memory input, input the setting for this mode.	P15
 Screen F2 	Zero/span adjustment	The validity of the zero/span adjustment and the setting value is confirmed. When "valid", F2.on - zero point adjustment (L) and span point adjustment (H) are alternately display. *The default is set with the full scale (- -).	Select whether to use with the full scale or with the zero and span adjusted. When zero/span adjustment is selected, the adjustment for this mode is set randomly.	P16
 Screen F3 	Automatic power off	The validity of the automatic power off function is confirmed. *The default is invalid (- -).	The validity of the automatic power off function is selected. Note: The automatic power off time is about 1 minute, and cannot be changed.	P16
 Screen F4 	Switch output *Switch output specifications only	Switch output validity and setting are confirmed. When "Mode 1 valid" is selected, F4.0 - tolerable range setting (L) - + tolerable range setting (H) is alternately displayed. When "Mode 2 valid" is selected, F4.1 - lower limit setting value (L) - upper limit setting value (H) will alternately display. *The default is invalid (- -).	Switch output validity is selected. When valid, mode 1 or mode 2 can be selected. The +/- tolerable values and upper/lower limit values can be set randomly. Note: The hysteresis width cannot be set.	P16

How to operate

RUN mode Display descriptions table

■ F1 (input signal selection) Screen F1 display details

The input signal type and target value are alternately displayed.

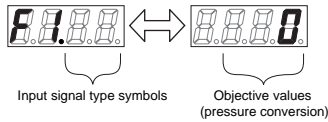

<Analog input type>

EVD-□-0□□-□-□, EVD-□-□□-□-□, EVD-□-2□□-□-□

Input signal type symbols	Descriptions
	Analog 0 to 10 VDC input
	Analog 0 to 5 VDC input
	Analog 4 to 20 mA DC input
	Preset memory input Selected preset no. is displayed.
	Direct memory input

<Digital input type>

EVD-□-P□□-□-□

Input signal type symbols	Descriptions
	Parallel 10bit input
	Direct memory input

■ F2 (Zero/span adjustment function) Screen F2 display details

The validity of zero/span adjustment and the setting are confirmed.

Note: This is invalid if preset or direct memory input is selected for F1 mode.

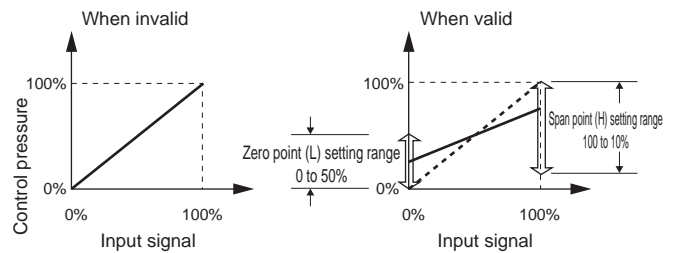
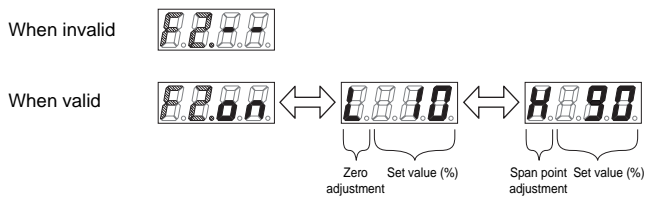

■ F3 (automatic power off) Screen F3 display details

The validity of automatic power off is confirmed.



■ F4 (switch output function) Screen F4 display details

Switch output validity and setting are confirmed.

Note: This is invalid with analog output specifications.

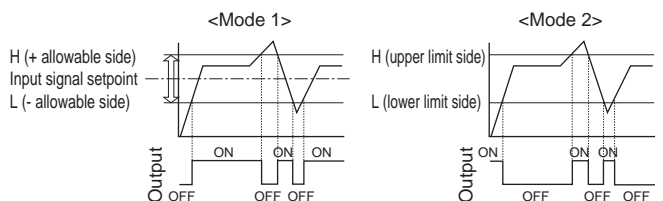
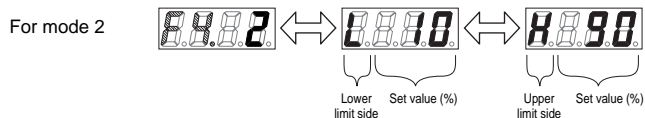
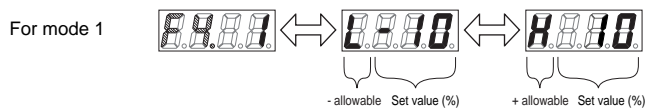

Setting mode Setting method Caution Release the key lock before changing setting details. (Refer to page 17)

■ Hold down the SET key for 2 seconds or longer with the F1 (input signal selection) screen F1 displayed. The F1 setting mode is entered.

- Changing analog input signal selection
Note: Analog input specifications cannot be changed.

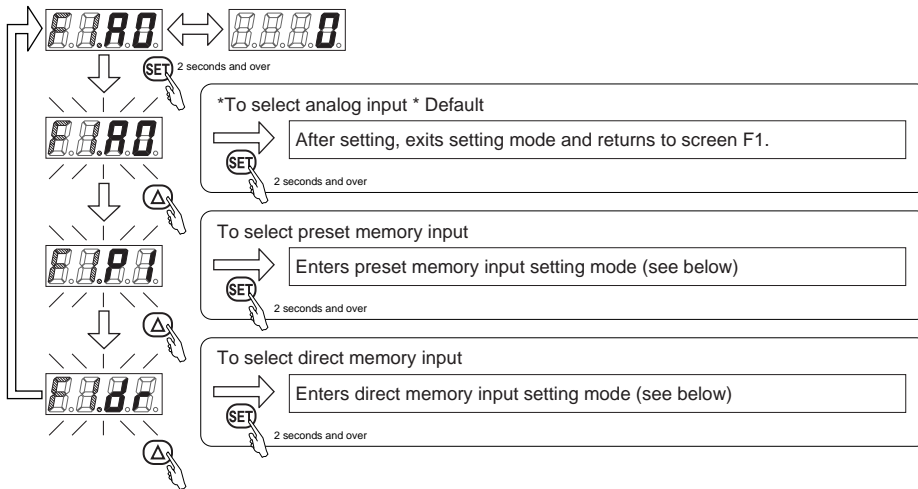

Exits input signal selection setting mode, and returns to screen F1.

- Changing parallel input signal selection

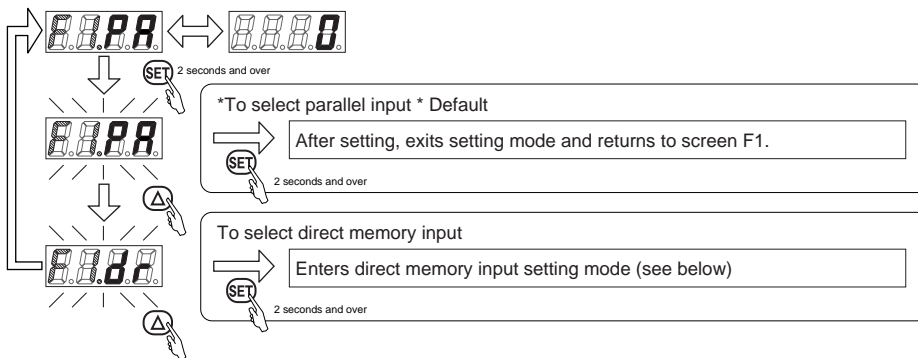

Exits input signal selection setting mode, and returns to screen F1.

- Using preset memory input setting mode

*Hold down the SET key for 2 seconds or longer with screen F1 preset memory input displayed.

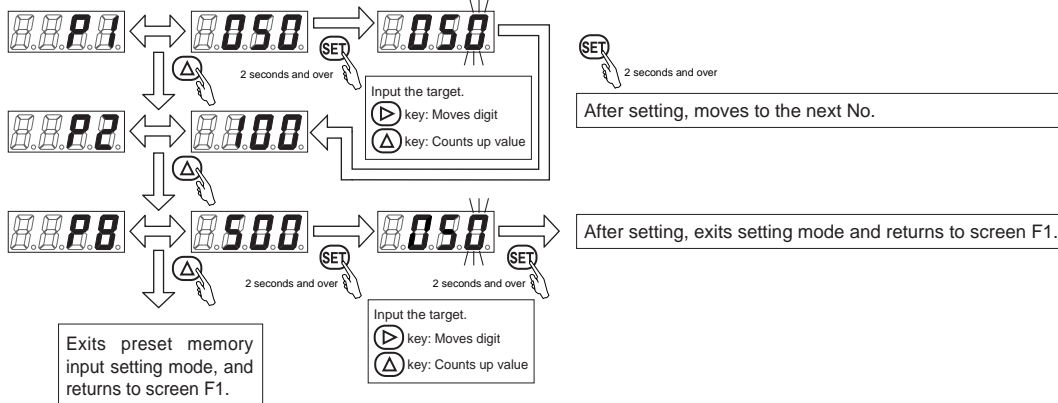

- Using direct memory input setting mode

*Hold down the SET key for 2 seconds or longer with screen F1 direct memory input displayed.

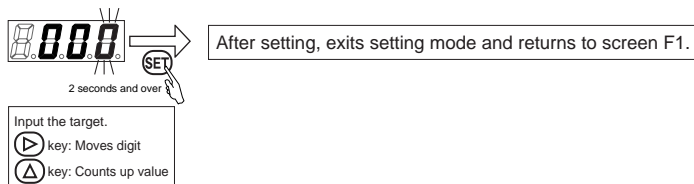

Setting mode Setting method Caution Release the key lock before changing setting details.(Refer to page 17)

■ Hold down the SET key for 2 seconds or longer with screen F2 (zero/span adjustment) screen F2 displayed. F2 setting mode is entered.

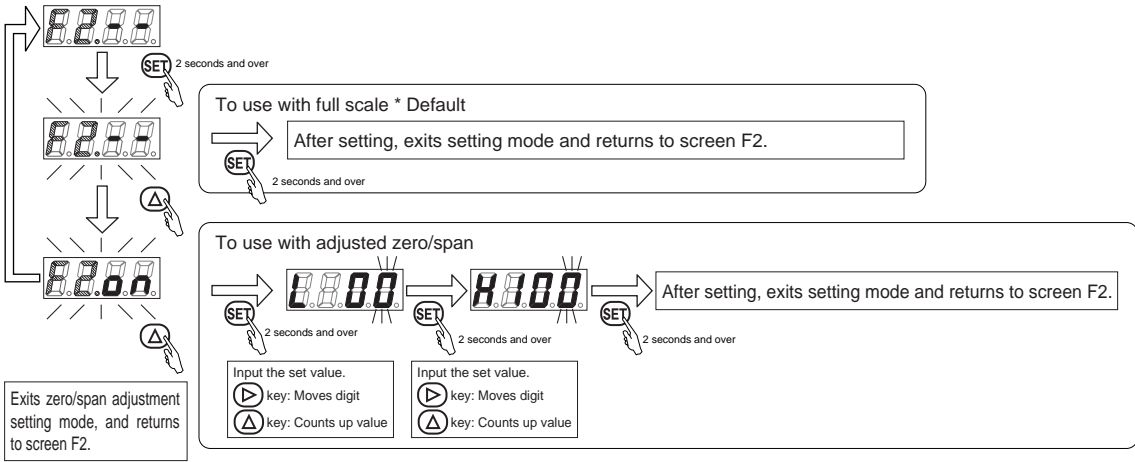

*This function cannot be used when preset or direct memory input is selected with F1 (input signal selection). Only full scale is used.

■ Hold down the SET key for 2 seconds or longer with screen F3 (automatic power off) screen F3 displayed. The F3 setting mode will be entered.

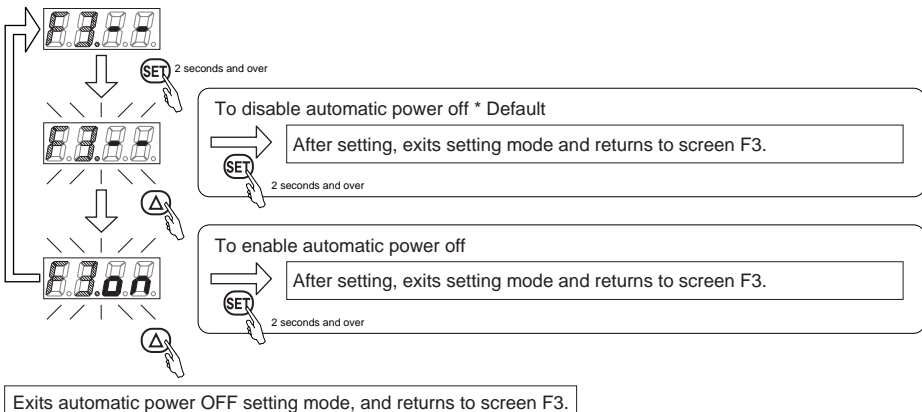

*If a key is pressed during automatic power off, the display will turn on.
*The automatic power off time is set to about 1 minute, and cannot be changed.

■ Hold down the SET key for 2 seconds or longer in with screen F4 (switch output function) screen F4 displayed. F4 setting mode is entered.

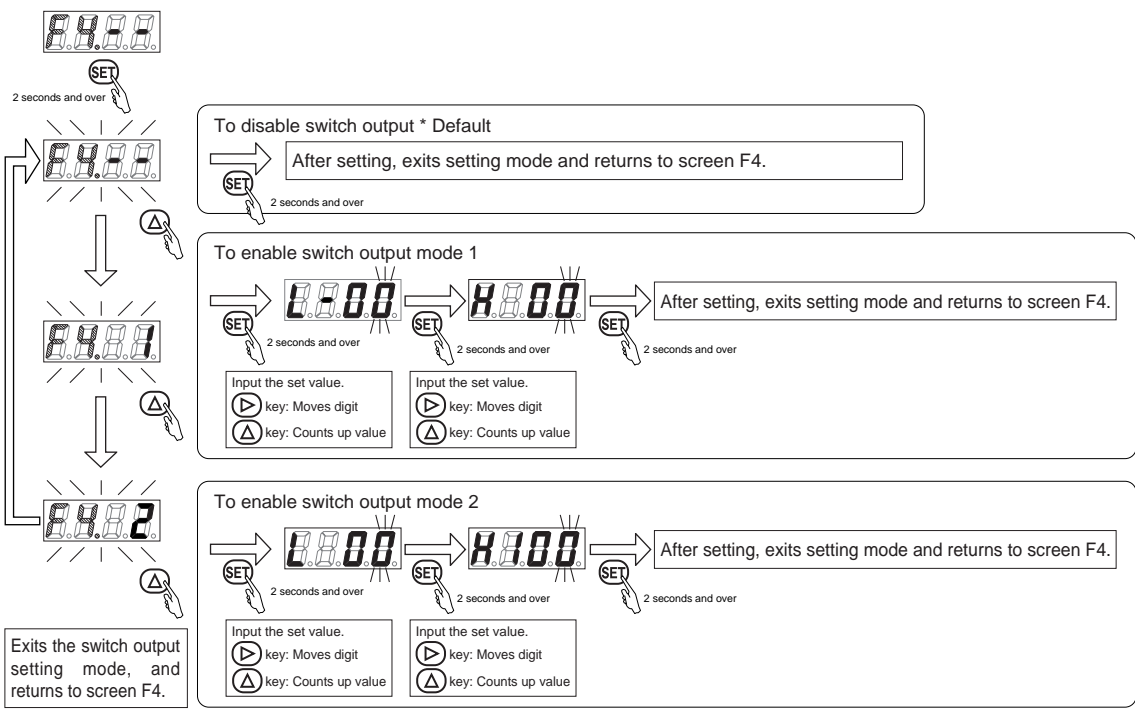

Key lock

This prevents incorrect operation. Release the key lock before changing settings.

● Operating the key lock

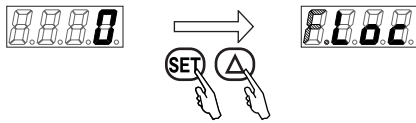

Hold down simultaneously for 2 seconds or longer

● Releasing the key lock

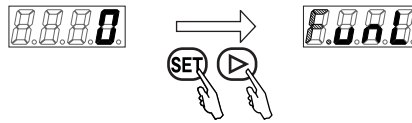

Hold down simultaneously for 2 seconds or longer

*The key is locked when power is turned on or turned on again.

Setting range of each function

Function	Setting display screen	Setting descriptions	Setting specifications
F1: Input signal selection For preset memory input 		Set the target pressure	Note 1 Range: 000 to 500 Minimum setting: 1 kPa
F1: Input signal selection For direct memory input 		Set the target pressure	Note 1 Range: 000 to 500 Minimum setting: 1 kPa
F2: zero/span adjustment function 		Set zero point adjustment.	Note 2 Range: 00 to 50 Minimum setting: 1%
		Set span point adjustment.	Note 2 Range: 100 to 010 Minimum setting: 1%
F4: switch output function For mode 1 		Set the - tolerable value.	Range: -00 to -50 Minimum setting: -1%
		Set the + tolerable value.	Range: 00 to 50 Minimum setting: 1%
F4: switch output function For mode 2 		Set the lower limit value.	Note 2 Range: 00 to 90 Minimum setting: 1%
		Set the upper limit value.	Note 2 Range: 100 to 010 Minimum setting: 1%

Note 1: If set to 5 kPa or less, it may not be possible to control pressure due to the effect of residual pressure.

Note 2: The setting range may be limited depending on the setting.





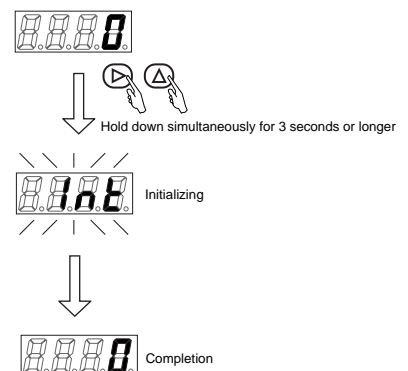

Default mode settings (initialization)

Screen display	Name	Setting display	Setting descriptions
Screen F1 	Input signal selection	Analog type Parallel type A0.A1.A2	Analog/parallel input
Screen F2 	Zero/span adjustment		Full scale (Zero/span adjustment invalid)
Screen F3 	Automatic power off		Automatic power off invalid
Screen F4 	Switch output *Switch output specifications only		Switch output invalid

Initialization



Error code

Error display	Cause	Measures
	Power voltage not within the rating.	Check regulator power specifications, set power voltage within the rated range, and turn power on again.
	Input signal exceeded rating.	Check the regulator's input signal, set the input signal within the rated range, and turn power on again.
	An error occurred during EEPROM reading or writing.	Contact your nearest CKD branch or dealer.
	An error occurred during memory reading or writing.	Contact your nearest CKD branch or dealer.
	Secondary pressure did not reach the set value for five or seconds or more.	Check primary pressure, supply pressure within the rating, and turn power on again. Check that there are no leaks from pipes, joints or other devices. Correctly connect, and turn power on again. If the error is not resolved, contact your nearest CKD branch or dealer.
	The switch output's overcurrent protection circuit has functioned.	Check whether load current exceeds the rating. Correctly connect, and turn power on again.

If the above errors occur, errors are displayed and error output turns on.

お問合せは
お近くの営業所へどうぞ

CKD株式会社

北海道

札幌営業所
〒060-0032 札幌市中央区北2条東14-26(苗穂駅前ビル1階)
TEL(011)232-1760 FAX(011)232-9050

東北

北上営業所
〒024-0034 岩手県北上市諏訪町2-4-26
TEL(0197)63-4147 FAX(0197)63-4186
仙台営業所
〒984-0015 仙台市若林区卸町2-2-1(パックス2-1階)
TEL(022)239-1851 FAX(022)239-1856
山形営業所
〒990-0834 山形県山形市清住町2-6-24
TEL(023)644-6391 FAX(023)644-7273
郡山営業所
〒963-8034 福島県郡山市島1-16-9
TEL(0249)23-6348 FAX(0249)24-0862

北関東

大宮営業所
〒330-0812 さいたま市北区宮原町3-429-1(第一清水ビル2階)
TEL(048)652-3811 FAX(048)652-3816
茨城営業所
〒300-0847 茨城県土浦市卸町1-1-1(閑鉄つくばビル4階C)
TEL(029)841-7490 FAX(029)841-7495
宇都宮営業所
〒321-0953 栃木県宇都宮市東宿郷3-1-9(USK東宿郷ビル3階)
TEL(028)638-5770 FAX(028)638-5790
太田営業所
〒373-0813 群馬県太田市内ヶ島町946-2(大観総合ビル1階)
TEL(0276)45-8935 FAX(0276)46-5628

南関東

東京営業所
〒101-0047 東京都千代田区内神田3-6-3(CKD第二ビル)
TEL(03)3254-4571 FAX(03)3254-7537
立川営業所
〒190-0022 東京都立川市錦町3-2-30(朝日生命立川錦町ビル3階)
TEL(042)527-3773 FAX(042)527-3782
千葉営業所
〒260-0021 千葉市中央区新宿2-5-19(千葉南ビル3階)
TEL(043)248-2815 FAX(043)248-2818
横浜営業所
〒222-0033 横浜市港北区新横浜2-17-19(日総第15ビル4階)
TEL(045)475-3471 FAX(045)475-3470
厚木営業所
〒243-0035 神奈川県厚木市愛甲1212-3
TEL(046)226-5201 FAX(046)226-5208
甲府営業所
〒409-3867 山梨県中巨摩郡昭和町清水新居1509
TEL(055)224-5256 FAX(055)224-3540
東京支店
〒101-0047 東京都千代田区内神田3-6-3(CKD第二ビル)
TEL(03)3254-3273 FAX(03)3256-9526

北陸・信越

長岡営業所
〒940-0088 新潟県長岡市柏町1-4-33(高野不動産ビル2階)
TEL(0258)933-5446 FAX(0258)933-5381
上田営業所
〒386-0034 長野県上田市大字中之条323-6(NFビル103号)
TEL(0268)24-2392 FAX(0268)24-2394
松本営業所
〒399-0033 長野県松本市大字笹賀5945
TEL(0263)25-0711 FAX(0263)25-1334
富山営業所
〒939-8064 富山県富山市赤田中町494-1
TEL(076)421-7828 FAX(076)421-8402
金沢営業所
〒920-0025 石川県金沢市駅西本町3-16-8
TEL(076)262-8491 FAX(076)262-8493

東海

名古屋営業所
〒485-8551 愛知県小牧市応時2-250
TEL(0568)73-9023 FAX(0568)75-1692
豊田営業所
〒473-0912 愛知県豊田市広田町広田103
TEL(0565)54-4771 FAX(0565)54-4755
静岡営業所
〒422-8035 静岡県静岡市宮竹1-3-5
TEL(054)237-4424 FAX(054)237-1945
浜松営業所
〒435-0016 静岡県浜松市和田町438
TEL(053)463-3021 FAX(053)463-4910
四日市営業所
〒510-0064 三重県四日市市新正5-3-20
TEL(0593)51-3151 FAX(0593)51-6788
名古屋支店
〒485-8551 愛知県小牧市応時2-250
TEL(0568)74-1356 FAX(0568)77-3317

関西

大阪営業所
〒542-0073 大阪府中央区日本橋1-17-17(銀泉 日本一ビル)
TEL(06)6635-2773 FAX(06)6643-5950
大阪東営業所
〒570-0083 大阪府守口市京阪本通1-2-3(損保ジャ/守口ビル2階)
TEL(06)543-6333 FAX(06)5991-7477
堺営業所
〒591-8021 大阪府堺市新金岡町5-5-6(泉マンション1階)
TEL(072)253-0071 FAX(072)253-0054
滋賀営業所
〒520-2361 滋賀県栗原市北野1-13-20(三甲ビル3階)
TEL(077)586-2070 FAX(077)586-2154
京都営業所
〒612-8414 京都市伏見区竹田段川原町35-3
TEL(075)645-1130 FAX(075)645-4747
奈良営業所
〒639-1123 奈良県大和郡市井筒町460-15(オッシュム・ロジナ1階)
TEL(0743)57-6831 FAX(0743)57-6821

神戸営業所

〒673-0016 兵庫県明石市松の内2-6-8(西明石スポーツビル3階)
TEL(078)923-2121 FAX(078)923-0212
大阪支店
〒542-0073 大阪府中央区日本橋1-17-17(銀泉 日本一ビル)
TEL(06)6635-2765 FAX(06)6643-5015

中国

広島営業所
〒734-0023 広島市南区東雲本町3-1-10
TEL(082)265-4455 FAX(082)265-2110
岡山営業所
〒700-0916 岡山県岡山市西之町10-104
TEL(086)244-3433 FAX(086)241-8872
山口営業所
〒747-0034 山口県防府市天神2-2-2
TEL(0835)38-3556 FAX(0835)22-6371

四国

高松営業所
〒760-0055 香川県高松市観光通2-2-15(ダイヤビル)
TEL(087)834-9640 FAX(087)834-9633
松山営業所
〒790-0921 愛媛県松山市福音寺町44-1(林マンション1階)
TEL(089)976-0477 FAX(089)976-0488

九州

北九州営業所
〒802-0976 北九州小倉南区南方5-13-34
TEL(093)964-0785 FAX(093)964-0910
福岡営業所
〒812-0006 福岡市博多区上牟田1-15-2
TEL(092)473-7136 FAX(092)473-5540
大分営業所
〒871-0015 大分県中津市牛神町1-1-11
TEL(0979)26-0725 FAX(0979)23-6866
熊本営業所
〒869-1103 熊本県菊池郡菊陽町久保田2698-1
TEL(096)340-2580 FAX(096)340-2584

本社

本社・工場
〒485-8551 愛知県小牧市応時2-250
TEL(0568)77-1111 FAX(0568)75-3715
営業本部
〒485-8551 愛知県小牧市応時2-250
TEL(0568)74-1303 FAX(0568)77-3410
海外営業部
〒485-8551 愛知県小牧市応時2-250
TEL(0568)74-1338 FAX(0568)77-3412

CKD Corporation 2-250 Uji Komaki, Aichi 485-8551, Japan PHONE+81-(0)568-74-1338 FAX+81-(0)568-77-3412

U.S.A

CKD USA CORPORATION
HEADQUARTERS
4080 Winnitka Avenue, Rolling Meadows, IL 60008 USA
PHONE +1-847-368-0539 FAX +1-847-788-0575
CINCINNATI OFFICE
1420 Jamike Drive, Erlanger, KY 41018 USA
PHONE +1-859-283-2776 FAX +1-859-283-2785
AUSTIN OFFICE
8403 Cross Park Drive, Suite 3G, Austin, TX 78754, USA
PHONE +1-512-821-9900 FAX +1-512-821-9903
SAN JOSE OFFICE
48501 Warm Spring Boulevard, Suite 114, Fremont, CA 94539 USA
PHONE +1-510-659-9245 FAX +1-510-659-9485

Europe

CKD EUROPE BRANCH
De Fruittuinen 28 Hoofddorp 2132NZ The Netherlands
PHONE +31-(0)23-5541490 FAX +31-(0)23-5541491

Malaysia

M-CKD PRECISION SDN.BHD.
HEADQUARTERS
Lot No.6, Jalan Modal 23/2, Seksyen 23, Kawasan, MIEL,
Fasa 8, 40300 Shah Alam, Selangor Darul Ehsan, Malaysia
PHONE +60(0)3-5541-1468 FAX +60(0)3-5541-1533
JOHOR BAHRU OFFICE
116&118 Jalan Rosmerah 2/17, Taman Johor Jaya, 81100
Johor Bahru, Malaysia
PHONE +60(0)7-352-9129 FAX +60(0)7-352-9144
MELAKA OFFICE
No.8-10, Ground Floor, Bachang Permai, Jalan Tun Fatimah
Batu Berendam 75350 Melaka, Malaysia
PHONE +60(0)6-286-9989 FAX +60(0)6-288-2700
PENANG OFFICE
No.2678, Ground Floor, Jalan Chain Ferry,
Taman Inderwasih, 13600 Prai, Penang, Malaysia
PHONE +60(0)4-399-9611 FAX +60(0)4-390-9811

Thailand

CKD THAI CORPORATION LTD.
SALES HEADQUARTERS-BANGKOK OFFICE
Suwan Tower, 14/1 Soi Saladaeng 1, North Sathorn Rd.,
Bangrak, Bangkok 10500 Thailand
PHONE +66(0)2-267-6300 FAX +66(0)2-267-6305

LAEMCHABANG OFFICE
53/67, 69 Moo 9, Tungskulka, Sriracha, Chonburi
20230 Thailand
PHONE +66(0)38-330-133 FAX +66(0)38-330-079

NAVANAKORN OFFICE
176/4-6, Moo 13, Paholyothin Rd., Klongneung, Klongluang,
Prathumthani 12120 Thailand
PHONE +66(0)2-909-2158 FAX +66(0)2-909-1168

RAYONG OFFICE
125/32 M.Charoen Nakorn, T.Maptapud, Rayong 21150,
Thailand
PHONE +66(0)38-608-549 FAX +66(0)38-609-299
LAMPHUN OFFICE
133 Moo 4, Bankiang Muang, Lamphun, 51000, Thailand
PHONE +66(0)53-582-116 FAX +66(0)53-582-079

Singapore

CKD SINGAPORE PTE LTD.
705 Sims Drive #03-01/02, Shun Li Industrial Complex,
387384 Singapore
PHONE +65-6744-2623 FAX +65-6744-2486

Taiwan

台湾旭開理股份有限公司
TAIWAN CKD CORPORATION
中華民國台灣省新竹縣竹北市泰和路176號
No.176 Taiho Rd. Chupei-City, Hsinchu Taiwan R.O.C
PHONE +886(0)3-553-5501 FAX +886(0)3-553-5505

China

喜開理(上海)機器有限公司
CKD(SHANGHAI)CORPORATION

営業部 上海事務所(SALES HEADQUARTERS / SHANGHAI OFFICE)
中国上海市浦东新区張橋路188号 湯臣商務中心3樓304室
Room 304, 3rd Floor, Tomson Business Center, No.188,
Zhang Yang Road, PuDong, Shanghai, 200120, China
PHONE +86-(0)21-58798266 Fax +86-(0)21-58797507

北京事務所(BEIJING OFFICE)

中国北京市復興路12号 恩菲科技大廈1015室
En-Fei-Ke-Ji Bdg. Room #1015, Fu-xing-Lu-Wu 12,
Beijing, 100038, China
PHONE +86-(0)10-63951008 FAX +86-(0)10-63957378

天津事務所(TIANJIN OFFICE)

中国天津市南開区白堤路148号
Bai-Di-Lu, 148, Nankai-Qu, Tianjin, 300193, China
PHONE +86-(0)22-27492788 FAX +86-(0)22-27483916

無錫事務所(WUXI OFFICE)
中国江蘇省無錫市中山路389号吟春大廈1708室
Room 1708, Yin-chun Bldg., Zhongshan Road No.389,
Wuxi, Jiangsu Province, 214001, China
PHONE +86-(0)510-2753506 FAX +86-(0)510-2750156

南京事務所(NANJING OFFICE)
中国南京市山西路57号杰源山西路商務中心502室
Room 502, Jieyuan Shanxi Road Business Center No.57,
Shanxi Road, Nanjing, 210009, China
PHONE +86-(0)25-86633426 FAX +86-(0)25-837335960

重慶事務所(CHONGQING OFFICE)
中国重慶市石橋鋪綏州路8号樂興科技廣場1634号
Taixing Keji Square Room 1634, Yuzhou Road No. 8
Shiqiaopu, Chongqing, 400039, China
PHONE +86-(0)23-68631161 FAX +86-(0)23-68631161

成都事務所(CHENGDU OFFICE)

中国四川省成都市西玉龍街210号成都外貿大廈22樓2207号
Chengdu Waimao Bldg. 22F, Room #2207, Xi-Yu-Long-Jie
210, Chengdu city, Sichuan Prov., 610015, China
PHONE +86-(0)28-86624906 FAX +86-(0)28-86620216

西安事務所(XIAN OFFICE)

中国陝西省西安市勞働南路296号西北航大610号
Xi-bei-min-hang Bldg. Room #610, Lao-dong-nan-lu 296,
Xian city, Shangxi Prov., 710082, China
PHONE +86-(0)29-88793422 FAX +86-(0)29-88709982

大連事務所(DALIAN OFFICE)

中国遼寧省大連市西南區新開路99号大連珠江國際大廈808室
DaLian Zhujiang GuoJi-Bld. Room #808, Xinkai-Lu 99,
DaLian city, Liaoning Province, 116011, China
PHONE +86-(0)411-83779312 FAX +86-(0)411-83779313

長春事務所(CHANG CHUN OFFICE)

中国吉林省長春市長春一光越野路16号單元4樓中門16-1
16-1 Dan Yuan 4-Lou Zhong Men, 16, Chang Chun Yi Qi
Yue Ye Lu, Chang Chun City, Jilin Province, 130011, China
PHONE +86-(0)22-27492788 FAX +86-(0)22-27483916

深圳事務所(SHENZHEN OFFICE)

中国深圳市福田区深南中路3027号嘉匯新城匯商中心1603室
Room 1603, Top Office, Glittery City, No.3027 Shennan
Road Central, Futian, Shenzhen, 518033, China
PHONE +86-(0)755-83646644 FAX +86-(0)755-83646699

Korea

CKD KOREA CORPORATION
Room No.1105, 11th Fl., The Korea Teachers Pension B/L 27-
2, Yoido-Dong, Youngdeungpo-Gu, Seoul, 150-742, Korea
PHONE +82-(0)2-783-5201 - 5203 FAX +82-(0)2-783-5204

Home Page Address <http://www.ckd.co.jp/>

このカタログに掲載の仕様および外観を、改善のため予告なく変更することがあります。
Specifications are subject to change without notice.