

Black Bruin



Product manual On-Demand Drive System

CTR101 / CTR201 and CVM120 / CVU200 valves

Contents

1	General instructions.....	4
1.1	About the manual.....	4
1.2	Intended use.....	4
1.3	Warranty.....	5
1.4	Product identification.....	5
1.5	Revision comments.....	5
2	Safety instructions.....	6
2.1	Warning symbols.....	6
3	Product description.....	7
3.1	Main components of the On-Demand Drive System.....	7
3.2	Control systems.....	8
3.3	Working principle.....	8
3.4	Driving mode.....	8
3.5	HDC function (Hill descent control) (option).....	9
3.6	Freewheeling mode.....	10
4	System design.....	11
4.1	Hydraulic motors.....	11
4.2	Valves.....	12
4.2.1	Valve models.....	12
4.2.2	Valve functions.....	12
4.3	Hydraulic system.....	13
4.4	Hydraulic connections.....	14
4.5	Port pairs.....	17
5	Control system.....	18
5.1	Model series of the control system.....	18
5.2	Product identification code.....	19
5.3	Control system connections.....	19
5.3.1	Important notes.....	19
5.3.2	Control system connection diagrams.....	20
5.3.3	Display cable with extension.....	22
5.3.4	Pressure sensor cables.....	22
5.3.5	Brake signal cable.....	23
5.3.6	Valve cable, Y.....	23
5.3.7	Valve cable, straight.....	23
5.3.8	Controller link cable.....	24
5.3.9	Power cable types.....	24
5.3.10	Protective caps.....	25
5.3.11	Resistor plug for the CAN OUT connector.....	25
5.3.12	HDC / AUX valve cable (optional accessory).....	26
5.3.13	Extension adapter cable for AUX valve (optional accessory).....	26
5.3.14	External alarm input cable (optional accessory).....	27

6	Installation and commissioning.....	28
6.1	Installation and the connections.....	28
6.2	Power-up the control system.....	30
6.3	Air bleeding procedure.....	31
6.4	Examine the connections.....	32
6.5	Test drive.....	32
7	Technical data.....	34
7.1	Control device.....	34
7.2	Display.....	35
7.3	Display mount.....	36
7.4	Pressure sensor.....	37
7.5	CVM120 2WD valve.....	38
7.6	CVM120 2WD HDC valve.....	39
7.7	CVM120 4WD valve.....	40
7.8	CVM120 4WD HDC valve.....	41
7.9	CVU200 valve.....	42

1 General instructions

1.1 About the manual

This manual contains the technical instructions for the Black Bruin On-Demand Drive System that uses CVM120/CVU200 valves and CTR101/CTR201 control systems. Obey these instructions when you plan to use the products.

All information is based on information that was available at the time that this manual was written. The manufacturer reserves the right to change the content of this manual without further notice.

Please visit www.blackbruin.com for the most recent version of this manual. The product datasheets and the 3D-models are available from the manufacturer by request.

The operation instructions of CTR101/CTR201 control systems are in the operation manuals:

- CTR101 control system Operation manual
- CTR201 control system Operation manual.



Note:

If there are differences between the English text and its translation, the English text is always the most accurate. This document is written in Simplified Technical English (ASD-STE100).

1.2 Intended use

The CVM120/CVU200 valves and the CTR101/CTR201 control systems are part of the Black Bruin On-Demand Drive System.

Black Bruin On-Demand Drive System is a transmission solution for tractor-driven trailers and working equipment.

Black Bruin On-Demand Drive System is very applicable for equipment that periodically requires additional power and is towed without hydraulics.

Black Bruin On-Demand Drive System is designed for off-road driving and must be powered off when you drive in road traffic.



Danger:

Make sure that you power off the system when you drive on road.

These products are only applicable to use together with the freewheeling Black Bruin motors. The valves and the control systems are specially made for transmission solutions with B200 series 2-speed motors. Please contact the manufacturer or their representative who will help you to select the most applicable motor model for your application.

The components of the On-Demand Drive System make driving functions easy to do. The manufacturer of the final product is responsible for the manufacture of the machine and that the product is correct for the application it is specially made for.

1.3 Warranty

Check the package and the product for transport damage when receiving goods. The package is not meant for long term storage; protect the product appropriately.

Do not dismantle the product. The warranty is void if the product has been disassembled.

The manufacturer is not responsible for damages resulting from misinterpreted, non-compliance, incorrect, or improper use of the product that goes against the instructions given in this document.

1.4 Product identification

The valves and the control systems have identification plates.

Refer to the CTR101 or CTR201 Operation manual for the instructions on how to verify the software version of the control system.

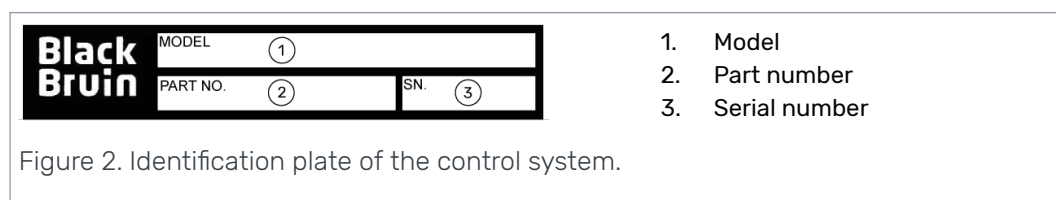

1.5 Revision comments

26.02.2021 (Software version 03.02.00) - This manual is published.

Previous CTR100 control system products are in the "CVM/CVU/CTR Product manual".

2 Safety instructions

The instructions that follow apply to all procedures related to the product. Read these instructions fully and follow them carefully.

- Use necessary personal protective equipment when you do work with the product.
- Use correct support with the product. Make sure that the product cannot accidentally fall or turn.
- Use only appropriate equipment and attachments when you lift and move the product.
- Make sure that it is not possible to pressurize the hydraulic lines during product installation and maintenance procedures.
- During the operation the product temperature can be over 60 °C (140 °F). Hot surfaces can burn you. Be careful of hot hydraulic fluid when you disconnect the hydraulic connections.

2.1 Warning symbols

The following symbols are used in this manual:



Note:

Useful information.



Danger:

Danger of death or injury.







Attention:

May cause damage to the product.

3 Product description

3.1 Main components of the On-Demand Drive System



<p>1</p>		<p>Valve</p> <ul style="list-style-type: none"> • Motor mode changes between driving and freewheeling • Driving direction change • Displacement control of two-speed motors • Pressure level (tractive power) adjustment • Assisting traction control (ATC) • Hill descent control (HDC) function (in selected models).
<p>2</p>		<p>Hydraulic motor</p> <ul style="list-style-type: none"> • Wheel hub motor • No pressure required in freewheeling mode • More extensive driving speed range with inbuilt two-speed valve.
<p>3</p>		<p>Control device</p> <ul style="list-style-type: none"> • Controls the system functions • Controls the valve • Measures the pressure from the system's pressure sensors • Monitors the brake signal • Monitors the external alarm signal (optional) • Controls the application specific auxiliary valve (optional) • Stores the system settings • Collects the speed and direction information via tractor's ISOBUS implement socket (CTR201).
<p>4</p>		<p>Display</p> <ul style="list-style-type: none"> • The system control element • Shows information to the user about the operation of the system • Many alternative languages.

3.2 Control systems

The two control systems, CTR101 and CTR201, have functions to control the driving mode in 2WD and 4WD applications.

CTR101 control system is applicable to all tractors. It provides driving functions that you can activate with the system display. It can also automatically switch the system to freewheeling mode if the working pressure drops due to increased driving speed.

CTR201 control system is applicable to tractors that have the ISOBUS implement connector. It has automatic functions that use the tractor's speed and direction information to make the operator's work easier. If necessary, manual operation of the system is also available.

3.3 Working principle

The Black Bruin On-Demand Drive System can use hydraulic motors in the operating modes that follow:

- Driving mode
 - Driving mode with HDC function (Hill descent control) (option)
- Freewheeling mode.

The chapters that follow give the working principles of these modes.

3.4 Driving mode

In this mode the motors help the vehicle to move in the direction of travel. You can adjust the tractive power level to the driving conditions. The power level stays constant also if the speed changes. When the tractor brakes the system reduces the working pressure to the minimum level and the hydraulic motors do not have tractive power.

2-speed hydraulic motors give wider speed range for the hydraulic drive.

If the vehicle wheels slip, the assisting traction control ATC increases the torque on the wheels that have more traction.

Typical situations to operate in the driving mode are:

- Driving up steep slopes



- Moving rearward on steep slopes



- Going across obstacles



- Driving on slippery or soft surfaces.



3.5 HDC function (Hill descent control) (option)

The HDC function helps when you drive the vehicle down on steep slopes, in both forward and reverse driving modes.

When the HDC function is active, the wheel motors resist the wheel movement to the driving direction. You can adjust the HDC power level during the operation.

Typical situations for the use of the HDC function are:

- Driving down steep slopes
HDC function off, vehicle accelerates.



- Driving down steep slopes
HDC function on, function helps the vehicle to maintain the speed.



- Moving rearward on steep slopes
HDC function off, vehicle accelerates.



- Moving rearward on steep slopes
HDC function on, function helps the vehicle to maintain the speed.



3.6 Freewheeling mode

In the freewheeling mode you can freewheel the motors without energy loss or overheating problems (stationary cylinder block - no centrifugal forces), even at high speeds. You can engage the drive again during movement when the speed is in the working range.

If the pressure level is not sufficient due to increased driving speed, the control system automatically switches to freewheeling. This protects the motor from overloading.

The operator can also manually change the mode to freewheeling.

Typical situations to operate in the freewheeling mode are:

- **When you drive on road**
- When you do work above the maximum working speed range
- When the working conditions are easy.

4 System design

4.1 Hydraulic motors

The technical data and the instructions to select the correct motor size are in the product manual of each motor series.

The items that are important when you select the motors for your system are:

- **The wheel load, radius and offset:**
 - These items give the minimum frame size for the motors.
- **The required tractive force:**
 - The pressure available from the hydraulics and the radius of the wheel give the necessary total displacement for the hydraulic motors. The necessary motor displacement is the total displacement divided by two (2WD system) or by four (4WD system).
- **Maximum speed when the drive is in use:**
 - The available flow from the pump and the flow capacity of the selected valve gives the maximum flow of the system. The 2-speed motor option makes it possible to use the partial displacement of the motor. Thus, you can use the drive in higher speed.

Guidelines to select the motors for the On-Demand Drive System:

- **Necessary:**
 - Mechanical freewheeling
- **Recommended:**
 - 2-speed function
 - Possible to use also 1-speed motors
- **Optional:**
 - Drum brake / disc brake
- **Not compatible:**
 - Internal freewheeling valve
- **Not compatible:**
 - Spring-loaded multidisc brake.

We recommend to use B200-series 2-speed motors for the On-Demand Drive System. Please contact the manufacturer or their representative who will help you to select the most applicable motor model for your application.

4.2 Valves

4.2.1 Valve models

Model series	CVM120 / 2WD CVM120 / 4WD	CVU200 / 2WD
Maximum flow rate (P->T)	120 l/min	200 l/min
Flow-rate limitation (in ATC function (A1-B1 / A2-B2)*)	2WD: 55 l/min / motor 40 l/min / motor (option) * 4WD: 28 l/min / motor	100 l/min / motor 80 l/min / motor (option) *
Compatible with fixed displacement pump	•	
Compatible with load-sensing (LS) pump	•	•
Hill descent control (HDC function)	0 (option)	
Valve order code	2WD without HDC: CVM120-A1H0T0V12S00 2WD with HDC: CVM120-A1H1T0V12S00 4WD without HDC: CVM120-A2H0T0V12S00 4WD with HDC: CVM120-A2H1T0V12S00	2WD without HDC: CVU200-A1H0T0V12S00

* Contact the motor manufacturer or its representative to order a valve for reduced flow.

4.2.2 Valve functions

CVM120 and CVU200 valves have the in-built functions that follow:

- Mode change between the freewheeling and driving modes
- Drive direction control
- Motor 2-speed function control
- Flow limitation for Assisting traction control (ATC)
- Proportional pressure level control
- Proportional Hill descent control (HDC) (available in selected valve models).

When a wheel slips, the ATC function gives up to 50% of the maximum flow of the valve to the wheel that slips. In the 4WD systems the maximum flow for each wheel is 25% of the maximum flow of the valve. In order to keep the pressure for the wheels that have better grip, the pump must supply sufficient flow to the wheel that slips.

CVM120 and CVU200 2WD valves are available with reduced flow capacity. With this option the ATC functions also on reduced flow capacity. Contact the motor manufacturer or its representative about this option.

4.3 Hydraulic system

When you plan to use the CVM120/CVU200 valves, make sure that:

- You use the CVU200 valve only in a system with a load-sensing pump and an LS line.
- The CVM120/CVU200 valves are not applicable to use in closed-circuit hydraulic systems.
- The hydraulic fluid viscosity must be a minimum of 15 cSt. The recommended viscosity is 25–50 cSt.
- The hydraulic fluid must be clean and its quality must be in accordance with ISO 4406. The minimum quality of the hydraulic fluid is 18/16/13.

The recommendations for the system filtration are in the table that follows:

Hydraulic supply	High pressure filter (P)	Return line filter (T)
Reservoir and pump in the tractor	Required	Optional
Reservoir and pump in the trailer	Optional	Required

- The hydraulic fluid temperature must be below 75 °C.
- You must monitor the hydraulic fluid temperature level during operation.
- It is very important to make sure that the cooling is sufficient during the use of the Hill descent control (HDC) option. If the cooling is not sufficient, the hydraulic fluid temperature can raise during the continuous use of the HDC function at high pressure. The conditions that have an effect on the necessary cooling capacity are, for example:
 - The working pressure
 - The flow
 - The ambient temperature
 - The duty cycle.



Note:

The working pressure line (P) of the system must have a pressure relief valve to limit the main pressure before the CVM120/CVU200 valve.

- We recommend that the hose sizes you use agree with the connections on the valve. Very small hose diameter causes pressure loss and interference in the operation.
- The position of the drain line ("C" in the hydraulic connection diagram) branching point must be as close to the valve as possible.
- You can use the pressure accumulators in the motor case drain-lines to extend the lifetime of the motor sealing. The use of the accumulators:
 - Can cut the case pressure peaks during drive activation
 - Makes the transition smoother from high flow drive to the freewheeling mode.
- Refer to the product manual of the motor series for more detailed information.

4.4 Hydraulic connections

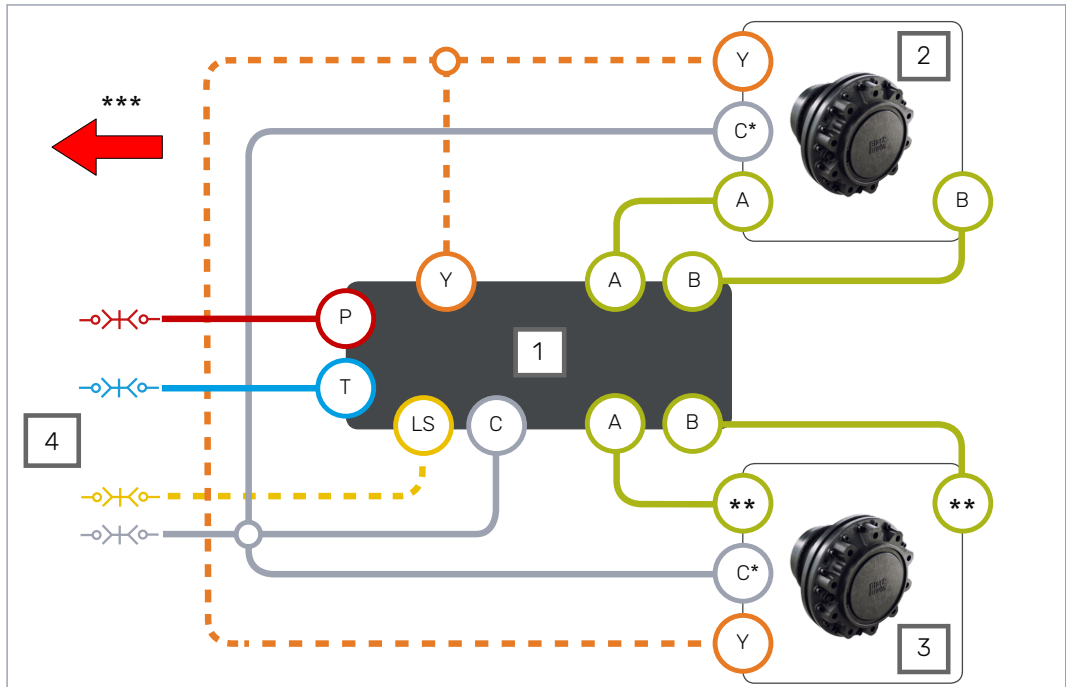

Figure 3. Connection diagram, 2WD.

1	Valve	2	Motor, right	3	Motor, left	4	Hydraulic lines to the tractor
---	-------	---	--------------	---	-------------	---	--------------------------------

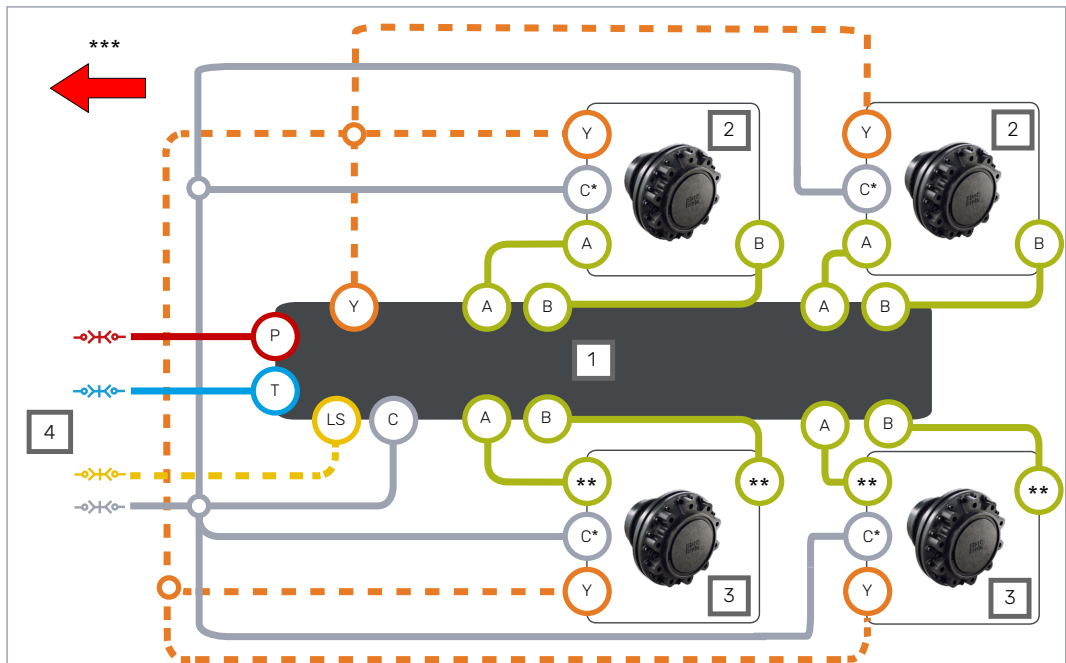

Figure 4. Connection diagram, 4WD.

1	Valve	2	Motor, right	3	Motor, left	4	Hydraulic lines to the tractor
---	-------	---	--------------	---	-------------	---	--------------------------------

* The drain line (C) has a mark (C2) in motors with flushing line (C1).

** Make sure that you verify the rotating direction of the left motor from the datasheet of the motor. Make sure that you connect the left motor correctly. Refer to the table that follows for the left motor connections.

*** Driving direction.

Table 1: Connections, motor to valve.

Vehicle side	Motor type	Connections: motor to valve	
Right side	1-speed	A to A	B to B
	2-speed, CW preferred	A to A	B to B
Left side	1-speed	A to B	B to A
	2-speed, CCW preferred	A to A	B to B



Attention:

The direction of rotation of the right motor must be CW.

Do not use 2-speed motors in the CW direction on the left-hand side.

We recommend that you use a Power Beyond hydraulic interface that connects to a load sensing pump. If it is not available, connect the lines P and T to the tractor valves.



Note:

The flow direction is from line P to line T.



Attention:

Do not put together lines C and T.

Always connect the line C to the reservoir without valves.

Table 2: Port sizes.

Port	Description	CVM120 valve	CVU200 valve
P	Pump - Working pressure inlet	G3/4"	G1"
T	Tank - Return line	G3/4"	G1"
C	Drain - Case leakage	G3/4"	G1"
A1, B1, A2, B2	Working lines for the motors	G1/2"	G3/4"
Y	2-speed function control line	G3/8"	G3/8"
LS	Load-sensing line	G1/4"	G1/4"
MC, MP, M_A2, M_B2	Measurement points for C, P, A2, B2	G1/4"	G1/4"



Note:

The motor datasheet has the motor port types and the rotating direction.

Selector valve

If you use the same hydraulic supply also to other functions (e.g. crane) with the drive system, you must usually separate the circuits with a selector valve. An example of a hydraulic system with a 3/2 selector valve is in the diagram that follows. In this example the selector valve (1) connects the working pressure (P) line to either

the CVM120/CVU200 valve (2) or to the crane valve (3). If the vehicle has a load-sensing system, a shuttle valve (4) is also necessary. The shuttle valve lets the selected valve to control the working pressure level.

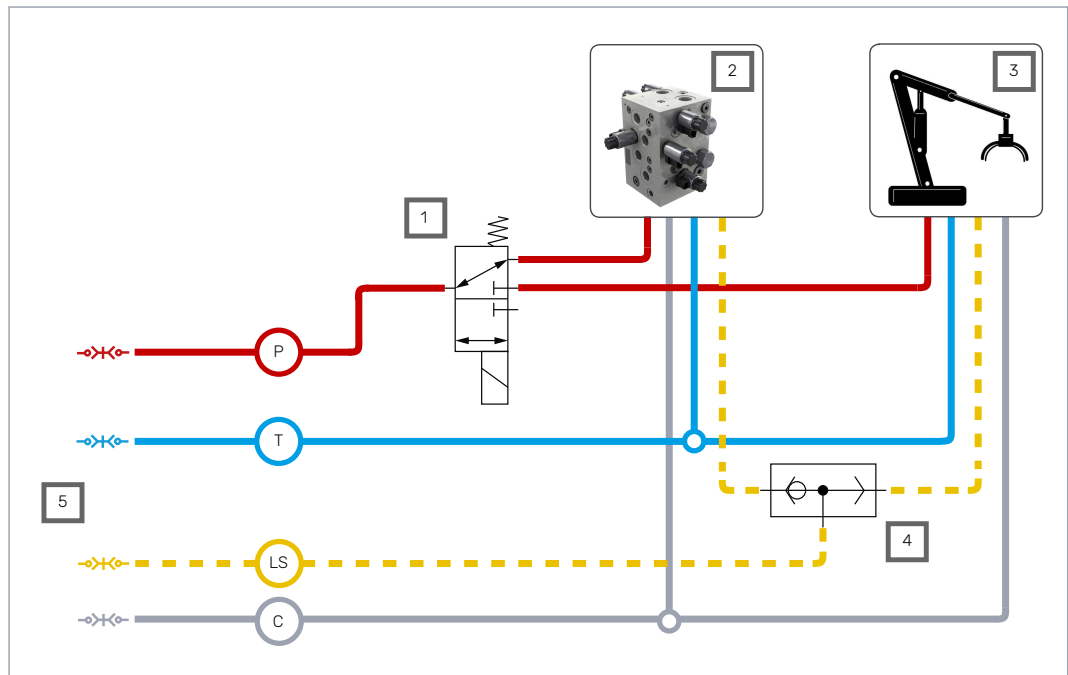

Figure 5. Connection diagram, selector valve.

1	Selector valve	2	CVM120/CVU200	3	Crane valve	4	Shuttle valve
5	Hydraulic lines to the tractor						

The CTR101 and CTR201 control systems have an “AUX output” function to control the external valve from the display. You can use this to control the selector valve. A maximum permitted current for the valve is 4 A (48 W, 12 V DC)



Attention:

You must connect the pressure inlet port (P) of the CVM120/CVU200 valve to the de-energized position of the selector valve. The auxiliary valve output is always de-energized during the driving mode and can energize only in the freewheeling mode.

You can also use the auxiliary output function for other control purposes in the maximum current range.

4.5 Port pairs

The port pairs of valve lines A and B have A1/B1 and A2/B2 marks.

Always connect each motor to a port pair as shown in the figure below.

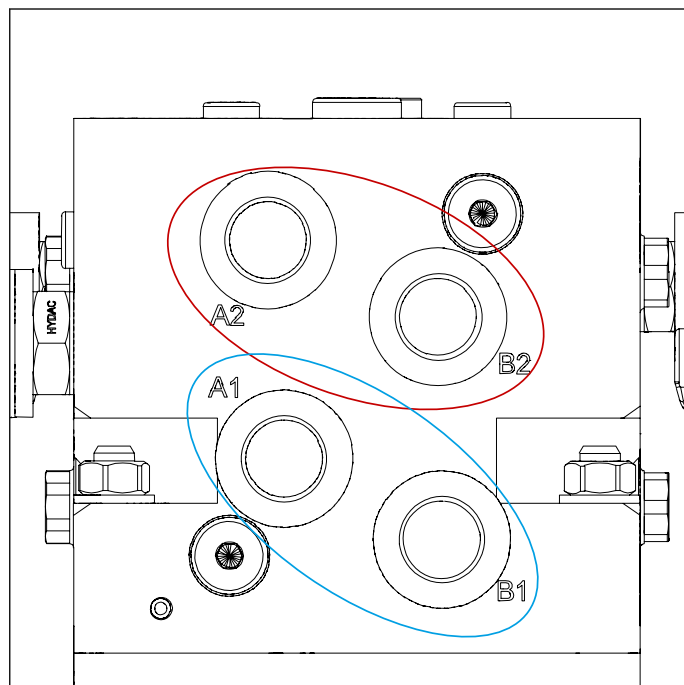

Figure 6. The port pairs.

You can connect left and right side motors to one of the two port pairs.

5 Control system

5.1 Model series of the control system

The table that follows shows the differences between the two control system models, CTR101 and CTR201.

The CTR201 control system can use the vehicle speed and direction information through the tractor ISOBUS implement-connector to control the driving functions.

	CTR101	CTR201
Connection to tractor ISOBUS implement-connector	-	●
Drive activation functions:		
Automatic, when the tractor starts to move	-	●
Automatic, when the system goes back to the working speed range	-	●
Manual drive activation	●	●
Automatic drive direction selection (ISOBUS)	-	●
Manual drive direction selection	●	● *M)
Tractive power cut-off during braking	●	●
Switching to freewheeling:		
Automatic, based on low pressure	●	●
Automatic, based on speed (ISOBUS)	-	●
Manual freewheeling	●	●
Shifting between low and high-speed range (2-speed function):		
Manual shift	●	● *M)
Automatic shift	-	●
Assisting traction control modes (ATC):		
Automatic mode, activation and deactivation based on speed	-	●
Activated after forward drive activation for a set time	●	-
Continuous operation	●	●
4WD valve control	0	0
HDC valve control *)	●	●
Auxiliary valve output function *)	●	●
External alarm input *)	●	●

- = not available, ● = available, 0 = option

M) Available when you operate the CTR201 in the manual mode.

*) Refer to the "Control system connections" for the necessary cables (see chapters *HDC / AUX valve cable (optional accessory)* on page 26, *Extension adapter cable for AUX valve (optional accessory)* on page 26 and *External alarm input cable (optional accessory)* on page 27).

5.2 Product identification code

The table that follows gives the identification codes for the model series of the CTR101 and CTR201 control system.

You can use the identification code to order the control system.

CTR101/CTR201 SERIES MODEL CODE		AAAAAA-BB-CCC-DDD-EE-FF	
On-Demand Drive control-system series CTR101 and CTR201			
AAAAAA: Control system series	AAAAAA-BB-CCC-DDD-EE-FF	CTR101	CTR201
	<u>CTR101</u>	•	
	<u>CTR201</u>		•
BB: Configuration	AAAAAA-BB-CCC-DDD-EE-FF	CTR101	CTR201
2WD	<u>A1</u> : Single controller for 2WD	•	•
4WD	<u>A2</u> : Dual controller for 4WD	•	•
CCC: Software	AAAAAA-BB-CCC-DDD-EE-FF	CTR101	CTR201
	<u>B00</u> : Standard software for CTR101	•	
	<u>C00</u> : Standard software for CTR201		•
DDD: Supply kit	AAAAAA-BB-CCC-DDD-EE-FF	CTR101	CTR201
	<u>I10</u> : 10 m power / ISOBUS cable with ISOBUS implement connector and terminating bias circuit		•
	<u>P10</u> : 10 m power cable with free +/- leads	•	
EE: Options 1	AAAAAA-BB-CCC-DDD-EE-FF	CTR101	CTR201
	<u>H0</u> : default / not defined	•	•
FF: Options 2	AAAAAA-BB-CCC-DDD-EE-FF	CTR101	CTR201
	<u>C0</u> : default / not defined	•	•

5.3 Control system connections

5.3.1 Important notes

When you plan to use the CTR101/CTR201 control system, make sure that:

- The nominal operating voltage of the control system is 12 V. Do not connect the system to a different voltage.
- The current requirement of the power supply of the system is 15 A. Make sure that you always use a connection with a fuse.
- When the control device has no power, the system switches the motors to freewheeling. Make sure that you can switch off the power supply to the control device from the tractor's cab.

Control system

- Attach the control device near the valve and in a location where the mechanical shocks or wear cannot cause damage to it. If necessary, use mechanical protection.
- Make sure that the installation location of the cables:
 - Does not cause too much force on the cables
 - Is not abrasive
 - Does not let the cables catch between the moving parts of the machine and break them.
- The system components are classified as water-resistant, but do not put the components fully into water.
- Install the display in the tractor cab. Use the mounting set that is supplied with the display. It includes a mounting frame and a pivot arm.
- You must start the control device again if the display cable disconnects and you connect it when the control system power is on. Switch the power off and on again.
- **CTR201:** Make sure that the tractor obeys the ISOBUS class 2 requirements. The automatic drive control mode will not operate correctly with an ISOBUS class 1 tractor.
- **CTR201:** Always use the ISOBUS implement connector (IBBC) when you connect the system to the tractor.

5.3.2

Control system connection diagrams

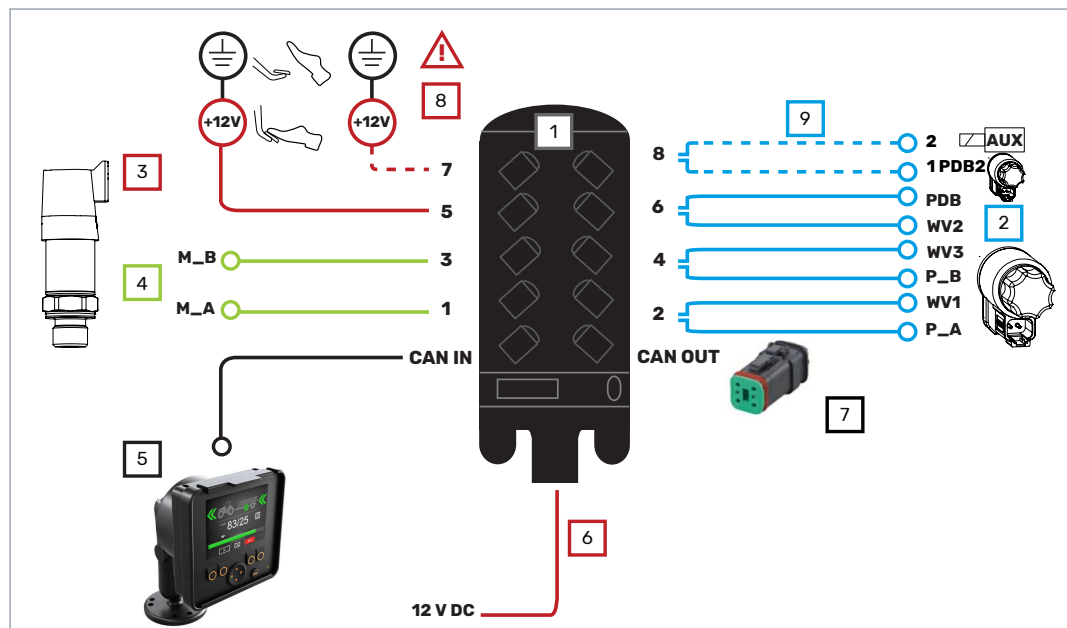

Figure 7. Connection diagram, 2WD.

Cables	Description	Cable ID	Length [m]
1	Control device		
2	Valve cables	WV1 / P_A WV3 / P_B PDB / WV2	1
3	Brake signal cable	Brake_sig	10
4	Pressure sensor cables	M_A, M_B	1
5	Display cable + extension	Display	10 + 0.3

6	CTR101: Power cable CTR201: Power / ISOBUS cable See chapter <i>Power cable types</i> on page 24.	-	10
7	Resistor plug	-	-
8	External alarm signal cable (accessory)	-	1
9	HDC / AUX valve cable (accessory)	2 / 1	1

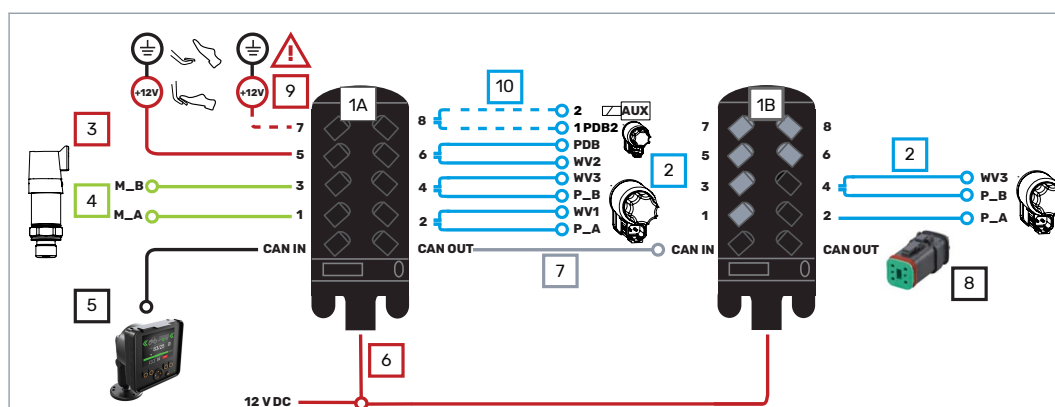

Figure 8. Connection diagram, 4WD.

1A	Control device - master		
1B	Control device - slave		
Cables	Description	Cable ID	Length [m]
2	Valve cables	WV1 / P_A WV3 / P_B PDB / WV2	1
3	Brake signal cable	Brake_sig	10
4	Pressure sensor cables	M_A, M_B	1
5	Display cable + extension	Display	10 + 0.3
6	CTR101: Power cable CTR201: Power / ISOBUS cable See chapter <i>Power cable types</i> on page 24.	- *) Master / Slave	10
7	Controller link	-	1
8	Resistor plug	-	-
9	External alarm signal cable (accessory)	-	1
10	HDC / AUX valve cable (accessory)	2 / 1	1

*) In CTR201 control system the master end of the cable connects to the 1A control device and the slave end of the cable connects to the 1B control device.

Verify the valve solenoid locations from the technical data (see chapter *Technical data* on page 34).

5.3.3 Display cable with extension

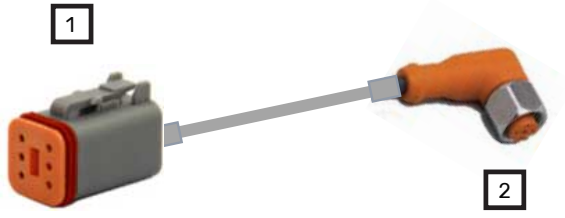
Display cable	
Use	Connects the display to the control device
Cable type	Straight 
Length	10 m
Head 1 design	Deutsch DT06-6S connector that connects to the control device.
Head 2 design	M12x15-pin that connects to the display extension cable. Can also connect directly to the display in fixed installations.

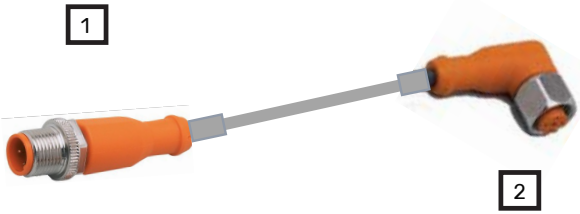
Display extension cable	
Use	Makes it possible to disconnect the display without removing it from the display carrier
Cable type	Straight 
Length	0.3 m
Head 1 design	M12x15-pin that connects to the display cable (10 m main cable).
Head 2 design	M12x15-pin that connects to the display.

5.3.4 Pressure sensor cables

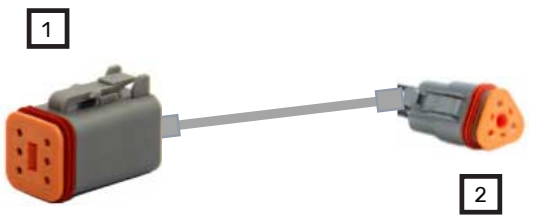
Use	Connects the pressure sensors to the control device
Cable type	Straight 
Length	1 m
Head 1 design	Deutsch DT06-6S connector that connects to the control device.
Head 2 design	Deutsch DT06-3S connector that connects to the pressure sensors.

5.3.5 Brake signal cable

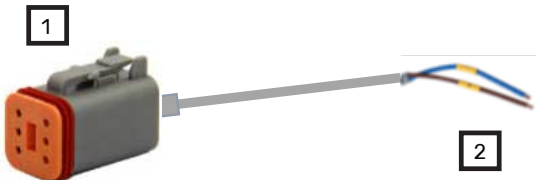
Use	Connects the brake signal to the control device	
Cable type	Straight	
Length	10 m	
Head 1 design	Deutsch DT06-6S connector that connects to the control device	
Head 2 design	Free conductors (2): <ul style="list-style-type: none"> • Brown (+) – Brake signal • Blue (-) – Ground level When the brake is active, the signal on "+" lead must be 12 V. When the brake is not active, the signal must be 0 V (ground level).	

5.3.6 Valve cable, Y

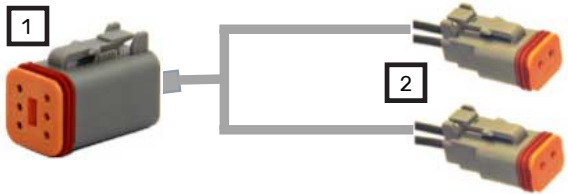
Use	Connects the control device to valves	
Cable type	Y cable	
Length	Each branch 1 m	
Head 1 design	Deutsch DT06-6S connector that connects to the control device	
Head 2 design	2 x Deutsch DT06-2S connectors that connect to the valves	

5.3.7 Valve cable, straight

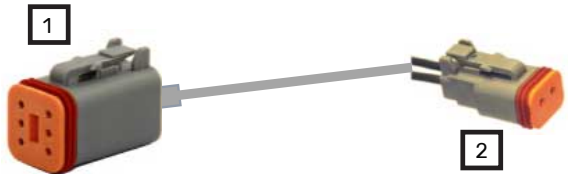
Use	Connects the control device to valves	
Cable type	Straight	
Length	1 m	
Head 1 design	Deutsch DT06-6S connector that connects to the control device	
Head 2 design	Deutsch DT06-2S connectors that connect to the valves	

5.3.8 Controller link cable

Use	Only in 4WD systems: Connection between the two control devices	
Cable type	Straight	
Length	Each branch 1 m	
Head 1 & 2 design	Deutsch DT06-6S connectors that connect to the two control devices	

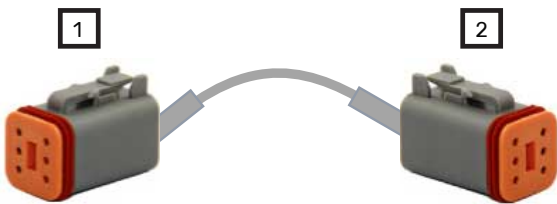

5.3.9 Power cable types

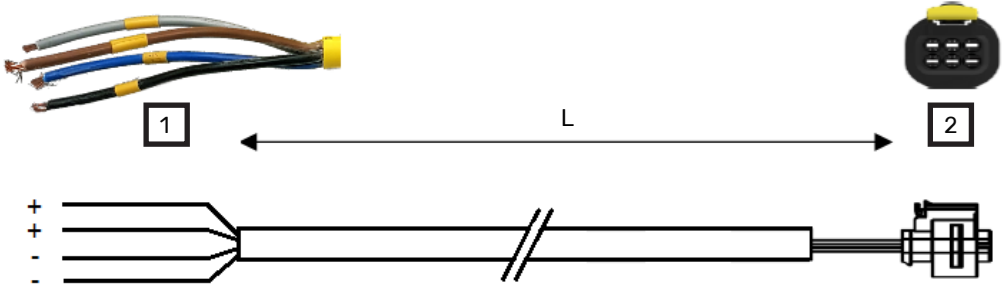
Power cable for CTR101 (Supply kit P10 in the identification code)		
		
Head 1 design	L = Length [m]	Head 2 design
Free conductors (4): "+" (2) and "-" (2)	10	AMP MCP2.8F

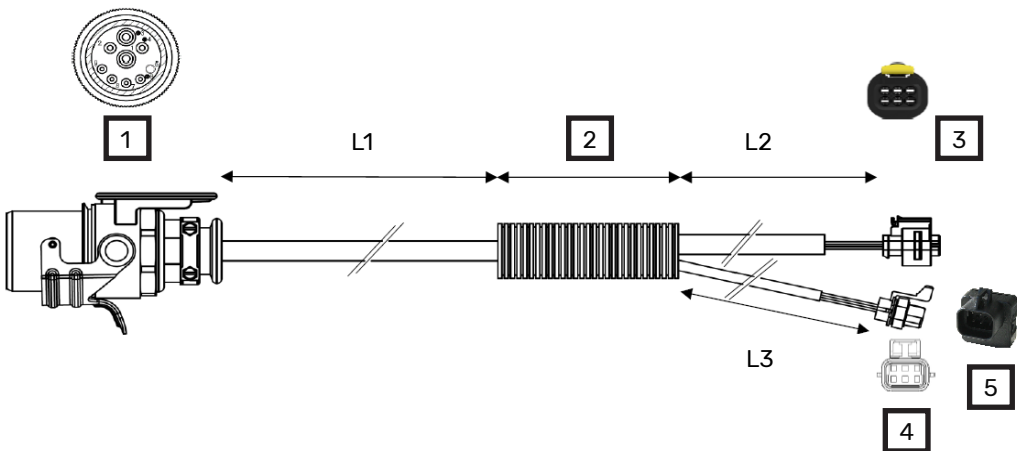
Power / ISOBUS cable for CTR201 (Supply kit I10 in the identification code)					
					
1	Isobus implement connector	2	Branching tube	3	AMP MCP2.8F
4	Aptiv 1205248	5	Terminating bias circuit		
L1 = 10 m		L2 = 0.5 m		L3 = 0.5 m	

Power / ISOBUS cable for CTR201 (Supply kit I10 in the identification code)	
Use the information that follows when you plan the installation:	
<ul style="list-style-type: none"> • The branching tube diameter is 30 mm • When you thread the cable, the hole size for the AMP connector and the TBC connector must be a minimum of 40 mm. 	

Use	The 4WD systems are also supplied with the Y cable. The Y cable connects to the power cable to power the two control devices.
Cable type	Y 
Length	Each branch 0.5 m
Head 1 design	AMP MCP-E connector to connect to the power cable
Head 2 design	2 x AMP MCP2.8F connectors to connect to the two control devices In the CTR201 control system the branches have labels for master and slave control devices (see the 4WD connection diagram in chapter Control system connection diagrams on page 20).

5.3.10

Protective caps

Use	To protect the connectors in the control device that are not in use
Image	

5.3.11



Resistor plug for the CAN OUT connector

Use	Terminates the controller CAN bus
Image	

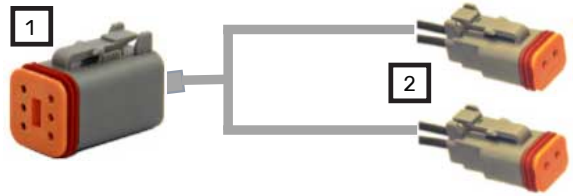
5.3.12 HDC / AUX valve cable (optional accessory)

Part number	50243003
Use	Connects the HDC valve and/or the auxiliary valve. This cable is necessary if you plan to use the HDC valve and/or the auxiliary valve.
Cable type	Y cable 
Length	Each branch 1 m
Head 1 design	Deutsch DT06-6S connector that connects to the control device
Head 2 design	2 x Deutsch DT06-2S connectors that connect to the HDC / AUX valves
Head 2 pinouts	1 – output (+) 2 – ground (-)

5.3.13 Extension adapter cable for AUX valve (optional accessory)

Part number	50241004
Use	Extends the AUX valve cable and connects to the valve that has the DIN43650 type A connector.  Note: This cable is an extension cable for the “HDC / AUX valve cable”, that is necessary.
Cable type	Straight 
Length	5 m
Head 1 design	Deutsch DT04-2P connector that connects to the HDC valve cable (part 50243003)
Head 2 design	DIN43650-A valve plug with LED indicator that connects to the auxiliary valve
Head 2 pinouts	1 – output (+) 2 – ground (-)

5.3.14 External alarm input cable (optional accessory)

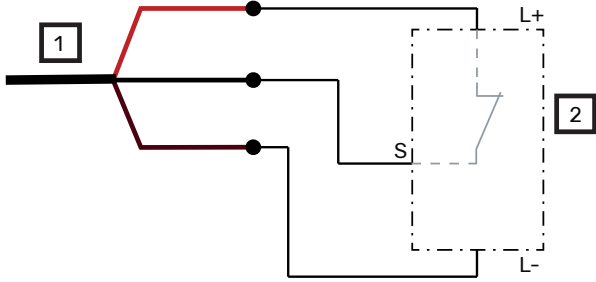
Part number	50248000
Use	<p>If the system detects an alarm signal, the external alarm signal connection prevents the use of the driving functions.</p> <p>Examples for the external alarm signal uses are connections to:</p> <ul style="list-style-type: none"> • The reservoir level switch • The hydraulic fluid temperature switch • The overpressure switch.
Cable type	Straight 
Length	1 m
Head 1 design	Deutsch DT06-6S connector that connects to the control device
Head 2 design	Free conductors to connect to the alarm input circuit.
Wiring	<p>Red – supply for circuit (12 V)</p> <p>Black – signal (0 / 12 V)</p> <p>Brown – ground</p> <p>The signal that you connect must be of a binary type (on / off). The connected signal can be either:</p> <ul style="list-style-type: none"> • Normally low (0 V) signals • Normally high (12 V) signals. <p>The figure shows an example of a connection of an electronic switch to the alarm input cable. For the correct connections to use in your system, refer to the technical data of the devices that you have.</p> 

6 Installation and commissioning

6.1 Installation and the connections

1. Examine the preferred rotating direction of the hydraulic motors to select the correct motors for the left and the right side.
2. Install the motors. Refer to the motor manual for the correct installation method.
3. Do not install the wheels at this time. You cannot complete the air-bleeding procedure if the wheels are installed. When you have completed the air-bleeding procedure and examined the connections, you can install the wheels.
4. Install the valve to an applicable location from the attachment points.
5. Connect the hoses to the valve. Obey to the hydraulic connection diagram (see chapter [Hydraulic connections](#) on page 14).



Note:

Be very careful with the drain line (C) connections:

- Make sure that the drain line to the reservoir does not have pressure.
 - If you pressurize the drain line, the hydraulic motor sealings break.
 - Mark the hoses. This is very important if the hydraulic supply is in the tractor.
6. Install the system's pressure sensors (400 bar) to the measurement points M_A2 and M_B2.



Note:

CVM120 4WD models: The valve has two pairs of M_A2 and M_B2 measurement points:

1. Install the pressure sensors to one of the two pairs.
 2. Put the metal plugs on the other pair that is not in use.
7. **CVM120 valve only:** Make sure that the DW valve (1) is correctly set. The pump type and the available connections have an effect on the adjustment. Rotate the adjustment knob by hand without any tools.

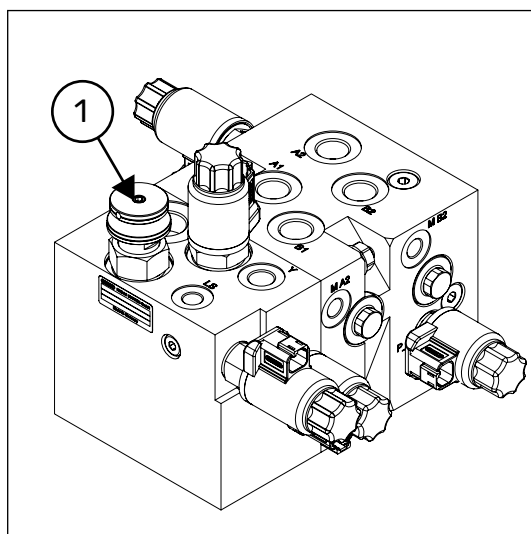

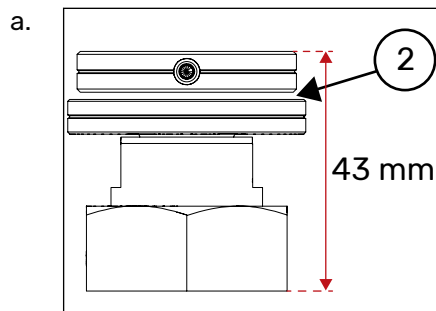

DW Valve adjustment when the valve is connected to the LS line.*

There is a small gap (2) between the adjustment knob and the locking nut, although the valve is in the fully closed position.

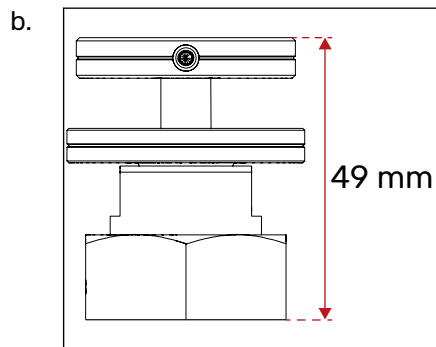

DW Valve adjustment when the LS line is closed with a plug.*

* Tighten the lower nut.

8. Replace the plastic plugs with metal plugs in all the ports that are not in use (metal plugs are not included in the delivery). Refer to the table of port sizes (see chapter [Hydraulic connections](#) on page 14).



Note:

- If the two-speed function is not in use, plug the Y connection on the valve.
- **CVM120 valve only:** If the tractor does not have the LS connection, plug the LS port on the valve.



Note:

Refer to the technical data for the locations of measurement points, ports etc. (see chapter [Technical data](#) on page 34).

9. Install the control device to an applicable location from the attachment points.



Danger:

Make sure that the system power is not on before you install the control device.

10. Connect all the cables. Make sure that you obey the connection diagram (see chapter [Control system connection diagrams](#) on page 20).



Note:

- **4WD only:** The control system has two control devices that are the same. The valve and signal connections set which one of the control devices is the master device and which one is the slave device.

11. Make sure that you use the correct CAN plug for the open CAN OUT socket.



12. **CTR201 only:** Connect the terminating bias circuit connector to the corresponding branch of the ISOBUS / power cable (see chapter *Power cable types* on page 24).
13. Make sure that you put protective caps on all the sockets in the control devices that are not in use (protective caps are included in the delivery).



6.2 Power-up the control system

1. Power-up the control system.
2. Make sure that the system configuration is correct:
 - **2WD:** No text on the control device segment-display. The green PWR led flashes.

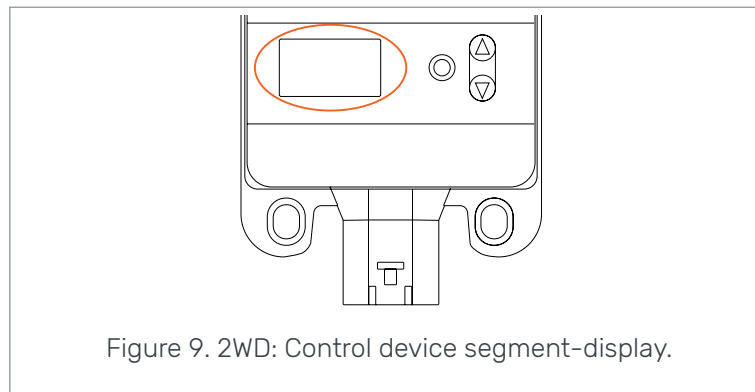

- **4WD:** One of the control devices shows **A** on the segment display and the other shows **B** on the segment display. The green PWR led flashes.

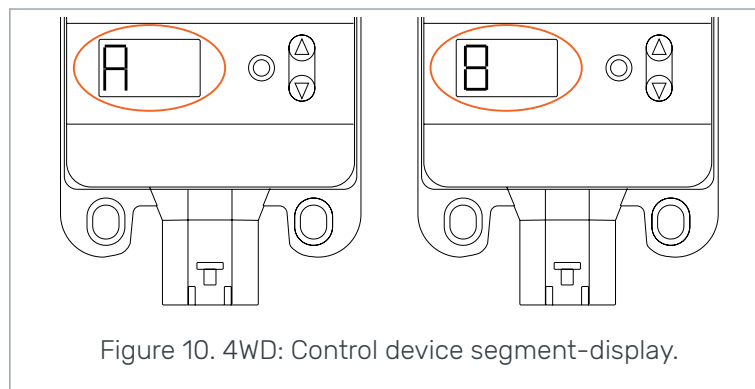

3. If the information on the display(s) is different, the system is not operating correctly. Examine the cable connections.

6.3 Air bleeding procedure

In the air bleeding procedure the motor housing is fully filled with the hydraulic fluid. The housing has air bleeding screws to remove the air from the housing. The control system can help in the procedure. Refer to the CTR101 or CTR201 Operation manual for the operation instructions.

Do the steps that follow:

1. Set the parameters for the air bleeding procedure as follows. Write down the initial values before you change them:
 - *Minimum pressure level [bar]* value as low as possible
 - *Minimum pressure delay [ms]* value as high as possible
 - *Drive activation ramp* value as high as possible.
2. Set the other parameter values. Refer to the CTR101 or CTR201 Operation manual. During this step, make sure that you select correct values for:
 - *Maximum pressure level [bar]*
 - *2-speed function*.
3. Do the air bleeding procedure for one motor at a time.
 - Find the air bleeding screws on the housing
 - Turn the motor to a position in which the screw is at its topmost position. You can use the control system to drive the motors to the correct position.



Note:

Use the 25 % power setting.

Keep the ATC function activated during the air bleeding procedure.



Note:

CTR201 only: Use the manual driving mode.

4. Loosen the air bleeding screw half a turn.
5. Drive the motor forward and rearward while you keep the air bleeding screw approximately +/- 45° of the topmost position.

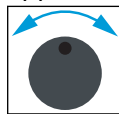

Continue the movement until hydraulic fluid flows out of the screw while it is at 12 o'clock position.



Note:

It is usual that the *Pressure low* warning shows on the system display during this procedure.

6. Tighten the screw. Make sure that the torque is correct. Refer to the product manual of the motor for the correct torque value.
7. Do the steps 3 thru 6 again to the remaining motors.
8. To make sure that the air bleeding of each motor is correct, the manufacturer recommends that you:
 - a. Drive each motor forward for one minute and rearward for one minute.
 - b. Repeat the air bleeding steps 3 thru 6.

9. To air bleed the 2-speed control pilot-line, do the steps that follow:
 - a. Loosen the Y-port fittings on the motor.
 - b. Select the D2 speed range on the control system.
 - c. Drive the motor forward.
 - d. When the hydraulic fluid flows through the fitting, tighten the connections back to the same tightness as before.

6.4 Examine the connections

To examine the hydraulic line and the cable connections do the steps that follow:



Note:

Use the 25 % power setting.

Keep the ATC function activated during the air bleeding procedure.



Note:

CTR201 only: Use the manual driving mode.

1. Use the forward and rearward driving functions to make sure that all the motors operate correctly to both directions.

If the driving direction selection does not operate correctly, examine:

 - The hydraulic working line connections (ports A and B)
 - The control system connections to valve solenoids P_A and P_B.
2. Make sure that the installation of the pressure sensors and the sensor cables is correct. Do the steps that follow:
 - a. Disconnect the cable from the pressure sensor on the measuring point *M_A2* on the valve.
 - b. The alarm message *Sensor_failure_pressure_A* shows on the display.
 - c. Connect the cable again.
 - d. Do the steps a thru c for the pressure sensor on the measuring point *M_B2* on the valve. The alarm message *Sensor_failure_pressure_B* shows on the display.
3. Activate the forward direction and change between D1 and D2 speed ranges to verify that the 2-speed control function operates correctly.
4. **HDC only:** Make sure that the HDC function is available and that it activates when you brake. If not:
 - a. Make sure that the connection of the valve cable is correct. See chapter [Control system connection diagrams](#) on page 20.
 - b. Examine the system parameters to make sure that the HDC function is enabled.
5. Change the parameter values back to their initial values. See chapter [Air bleeding procedure](#) on page 31.

6.5 Test drive

1. Install the wheels.
2. The system is now ready for the test drive. Refer to the CTR101 or CTR201 Operation manual for the operation of the system.

**Note:**

- The tractors have different pump models that operate differently. Thus, when you connect the system to the tractor you use, you must do more detailed testing and set the parameters correctly. More specific information about the parameters, the alarm messages and the troubleshooting instructions are in the CTR101 or CTR201 Operation manual.
3. Activate the driving function.
 4. Start driving slowly:
 - a. Monitor the measured tractive power level.
 - b. Change between the set tractive power levels during the drive.
 - c. The measured value on the display decreases and increases with the level change.
 - d. If the measured value does not stay clearly below the 100 % when you use the maximum tractive power level, decrease the value of the parameter *Maximum pressure level [bar]*.

**Note:**

- The measured values can be different from the selected levels. This is usual for low tractive power levels.
5. Change to freewheeling during driving. The motors make a short, approximately 1 - 3 seconds, rattling sound. Constant noise from the motors during freewheeling is not permitted.
 6. **Only HDC:** Do the HDC function test with different set levels.

7 Technical data

7.1 Control device

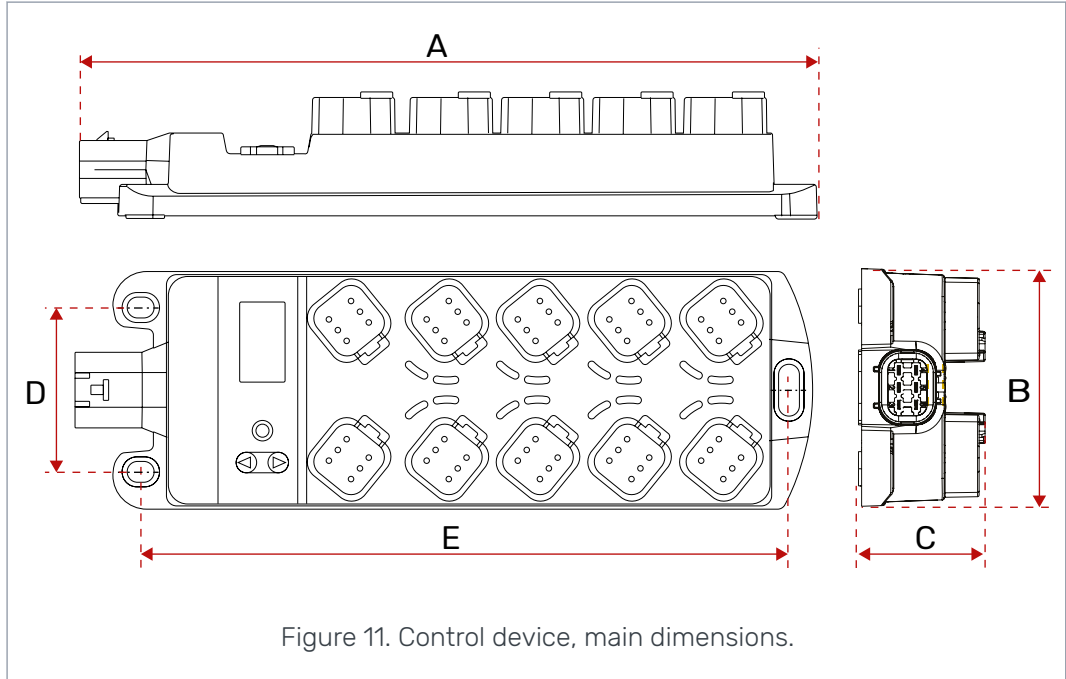

External dimensions without cables (A x B x C)	234.2 mm x 76 mm x 40.5 mm
Control device attachment point dimensions (D x E)	52 mm x 205.5 mm
Protection class	IP 65, connectors attached: IP 67
Operating temperature	-40...+85 °C
Operating voltage	12 V DC
Power consumption	Max. 15 A



Note:

Free space required for connectors and connector cables: 100 mm above the control device and 100 mm in front of the power connector.

7.2

Display

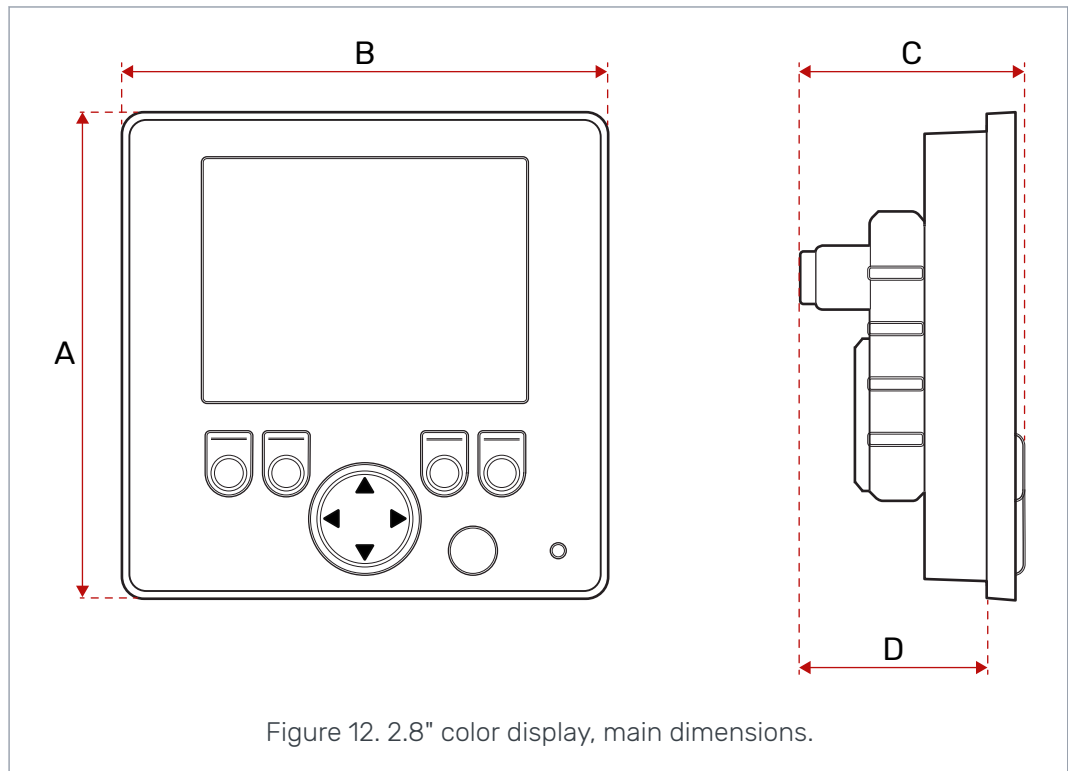
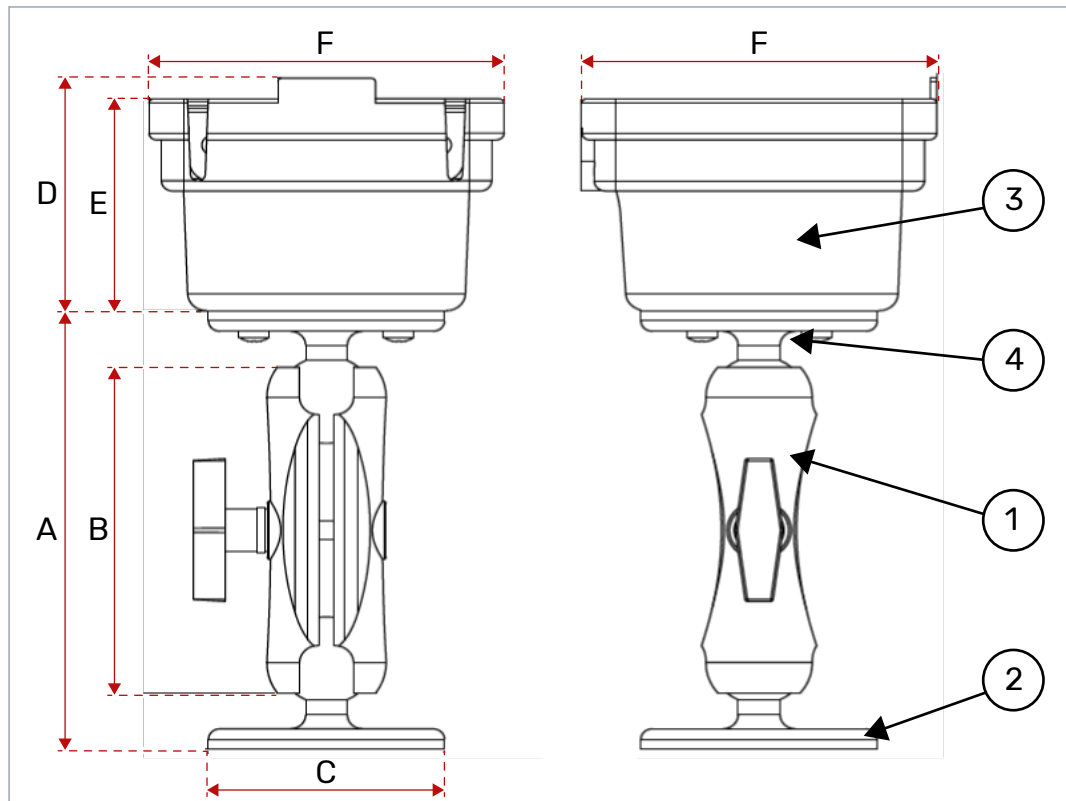

Figure 12. 2.8" color display, main dimensions.

External dimensions (A x B x C/D)	87.5 mm x 87.5 mm x 37.8 mm /31.3 mm
Opening size in panel installation	81.5 ± 0.5 mm x 81.5 ± 0.5 mm
Protection class	IP 67 (installed) / IP 65 (not installed)
Operating temperature	-20...+70 °C

7.3 Display mount



	Part	Material	External dimensions
1	Mounting arm	Aluminum black anodized	A/B: 128 mm/95 mm
2	Mounting plate	Aluminum black anodized	Diameter C: 62 mm
3	Display carrier	Plastic black	D/E x F: 68 mm/62 mm x 93 mm
4	Ball	Rubber	-

7.4 Pressure sensor

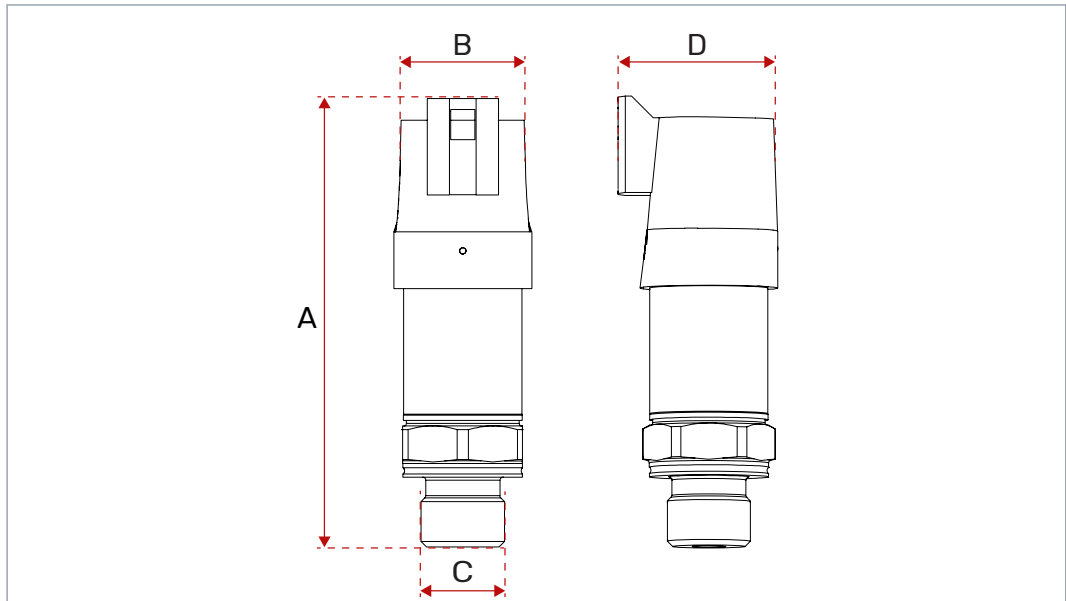

Figure 13. Pressure sensor, main dimensions.

External dimensions (A x B/D)	71.5 mm x 21.8 mm / 25.4 mm
Measurement range	0...400 bar
Cable connector	Deutsch DT04-3S
Process connection (C)	G1/4"

7.5 CVM120 2WD valve

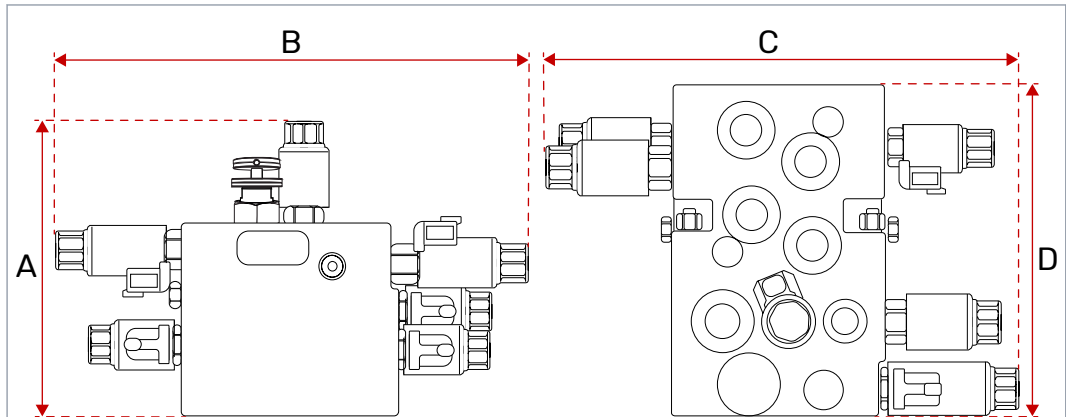

Figure 14. CVM120 2WD valve, main dimensions.

Order code	CVM120-A1H0T0V12S00
External dimensions (A x B)	196 mm x 307 mm
External dimensions (C x D)	307 mm x 221 mm
Weight	26.5 kg
Maximum pressure level	350 bar
Maximum flow rate	120 l/min
Operating voltage	12 V DC
Compatible pump	Load-sensing (LS) or fixed displacement, operation type is selected from the valve.

Refer to the valve datasheet for more detailed technical information and dimensions.

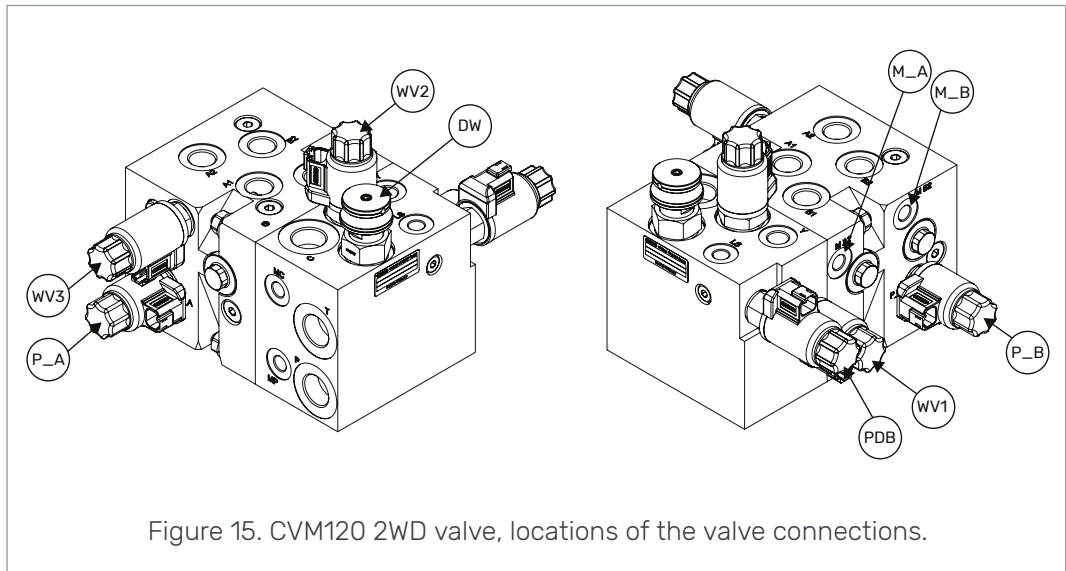

Figure 15. CVM120 2WD valve, locations of the valve connections.

7.6 CVM120 2WD HDC valve

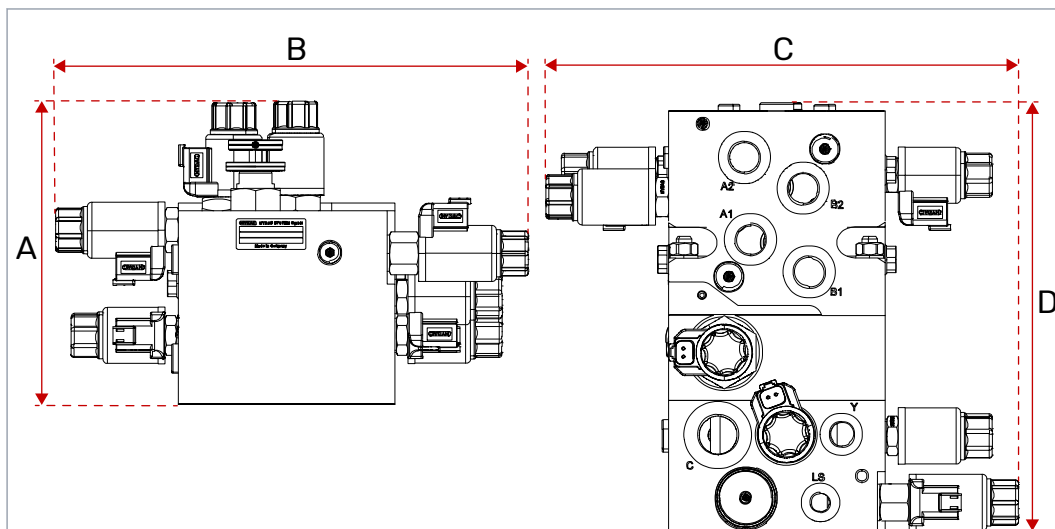

Figure 16. CVM120 2WD HDC valve, main dimensions.

Order code	CVM120-A1H1T0V12S00
External dimensions (A x B)	196 mm x 307 mm
External dimensions (C x D)	307 mm x 276 mm
Weight	33.5 kg
Maximum pressure level	350 bar
Maximum flow rate	120 l/min
Operating voltage	12 V DC
Compatible pump	Load-sensing (LS) or fixed displacement, operation type is selected from the valve.

Refer to the valve datasheet for more detailed technical information and dimensions.

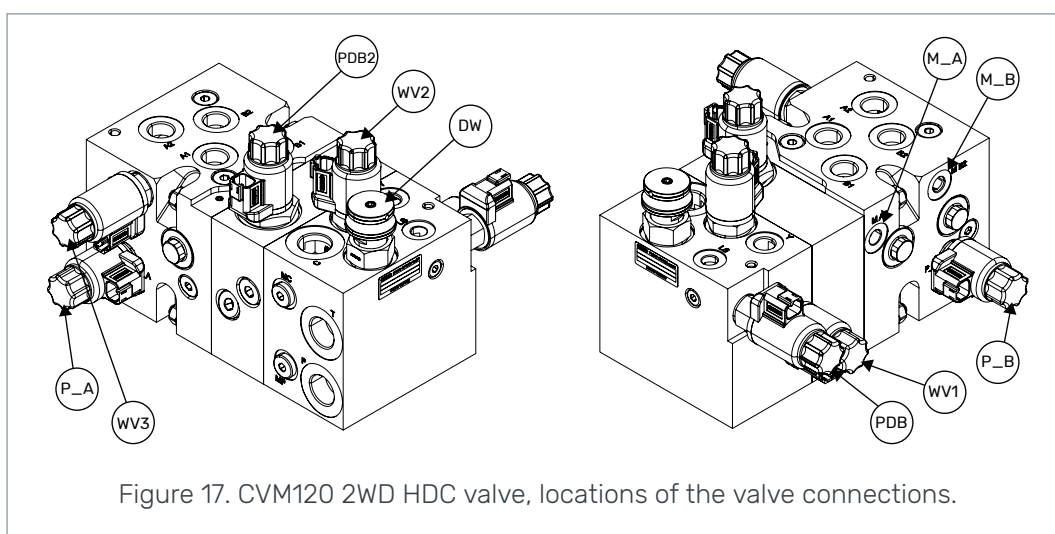

Figure 17. CVM120 2WD HDC valve, locations of the valve connections.

7.7 CVM120 4WD valve

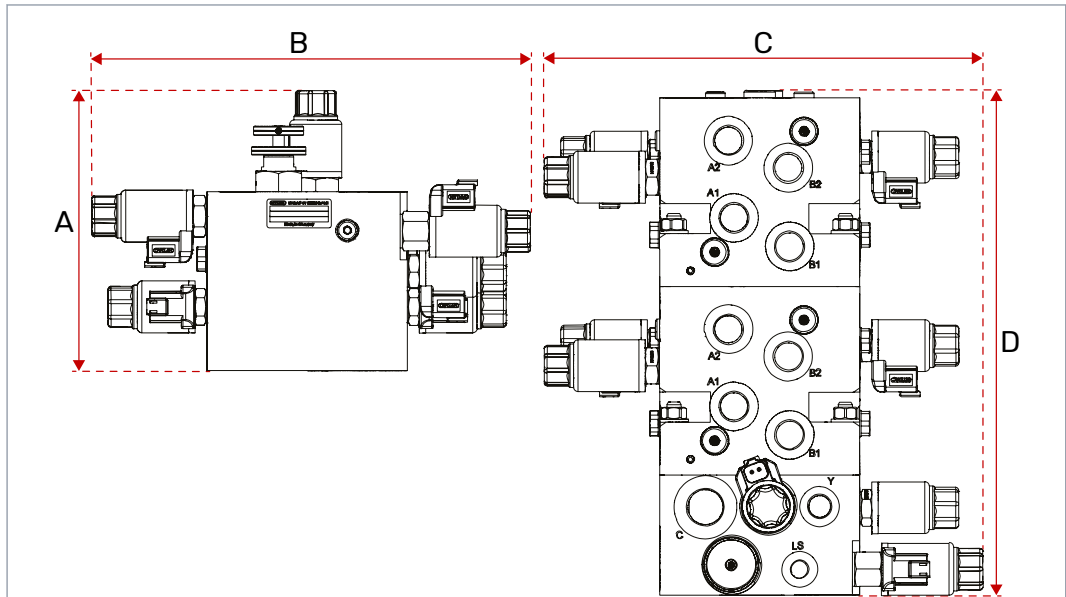

Figure 18. CVM120 4WD valve, main dimensions.

Order code	CVM120-A2H0T0V12S00
External dimensions (A x B)	196 mm x 307 mm
External dimensions (C x D)	307 mm x 353 mm
Weight	42.2 kg
Maximum pressure level	350 bar
Maximum flow rate	120 l/min
Operating voltage	12 V DC
Compatible pump	Load-sensing (LS) or fixed displacement, operation type is selected from the valve.

Refer to the valve datasheet for more detailed technical information and dimensions.

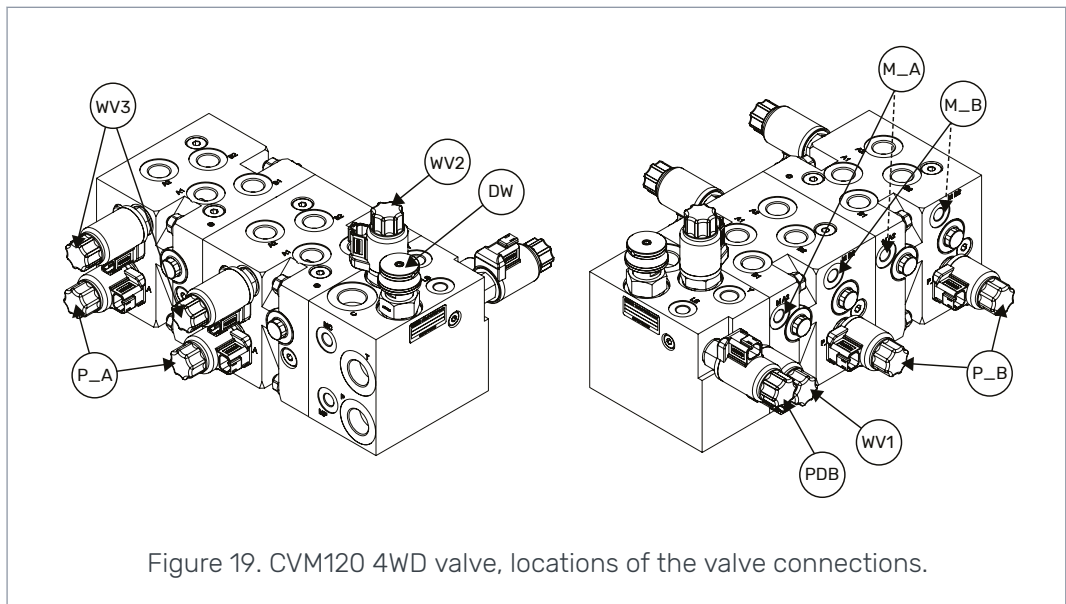

Figure 19. CVM120 4WD valve, locations of the valve connections.

7.8 CVM120 4WD HDC valve

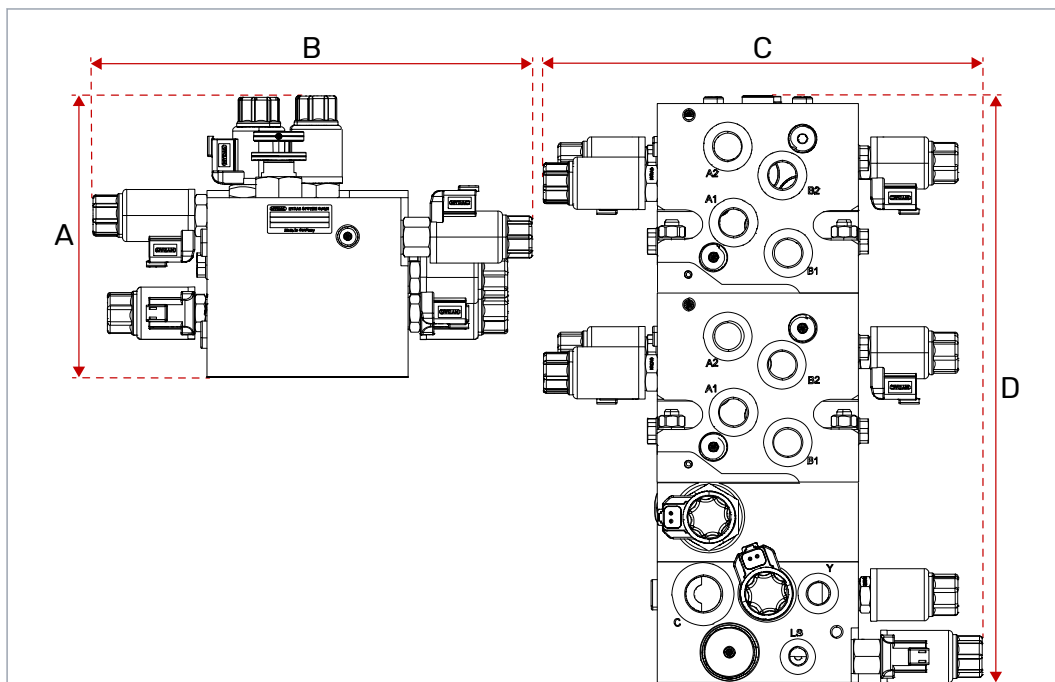

Figure 20. CVM120 4WD HDC valve, main dimensions.

Order code	CVM120-A2H1T0V12S00
External dimensions (A x B)	196 mm x 305.5 mm
External dimensions (C x D)	305.5 mm x 408.3 mm
Weight	49.3 kg
Maximum pressure level	350 bar
Maximum flow rate	120 l/min
Operating voltage	12 V DC
Compatible pump	Load-sensing (LS) or fixed displacement, operation type is selected from the valve.

Refer to the valve datasheet for more detailed technical information and dimensions.

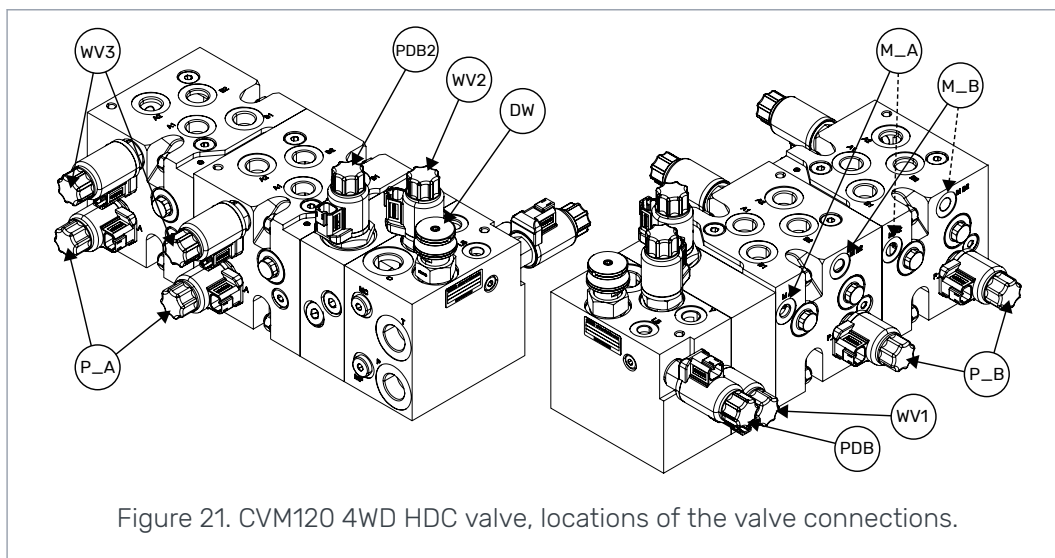

Figure 21. CVM120 4WD HDC valve, locations of the valve connections.

7.9 CVU200 valve

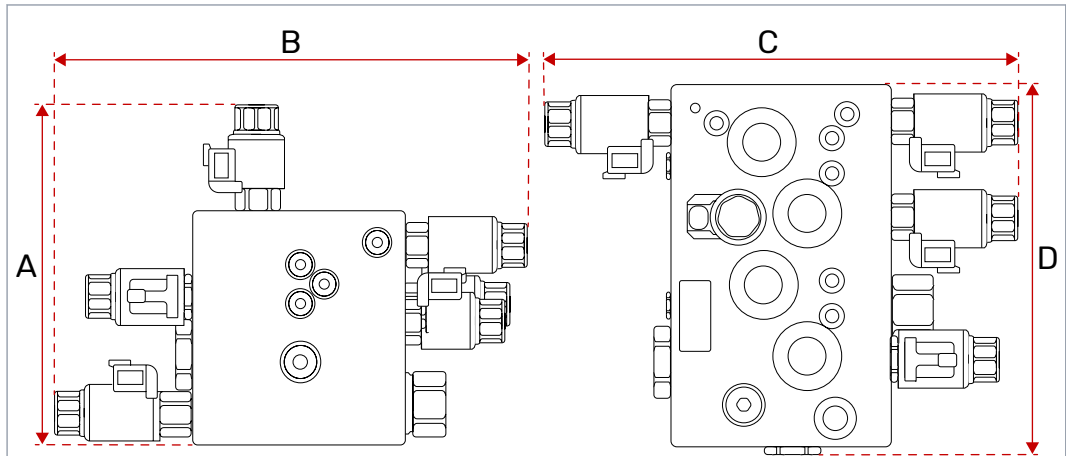

Figure 22. CVU200 valve, main dimensions.

Order code	CVU200-A1H0T0V12S00
External dimensions (A x B)	228 mm x 315 mm
External dimensions (C x D)	315 mm x 240 mm
Weight	36.0 KG
Maximum pressure level	350 bar
Maximum flow rate	200 l/min
Operating voltage	12 V DC
Compatible pump	Load-sensing (LS), external LS interface (Power Beyond).

Refer to the valve datasheet for more detailed technical information and dimensions.

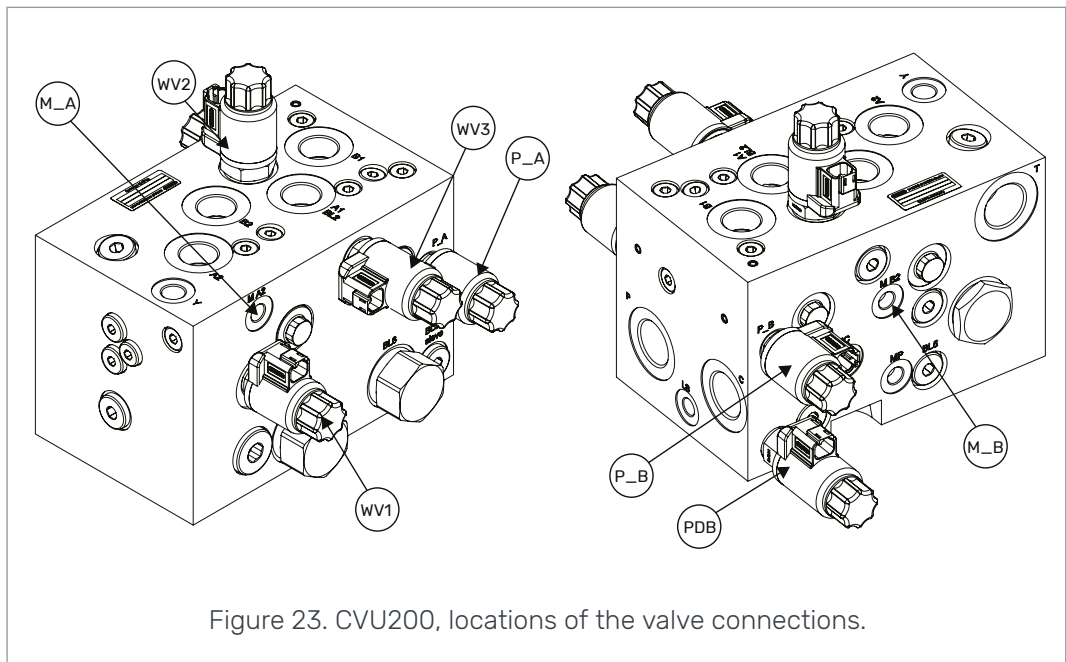
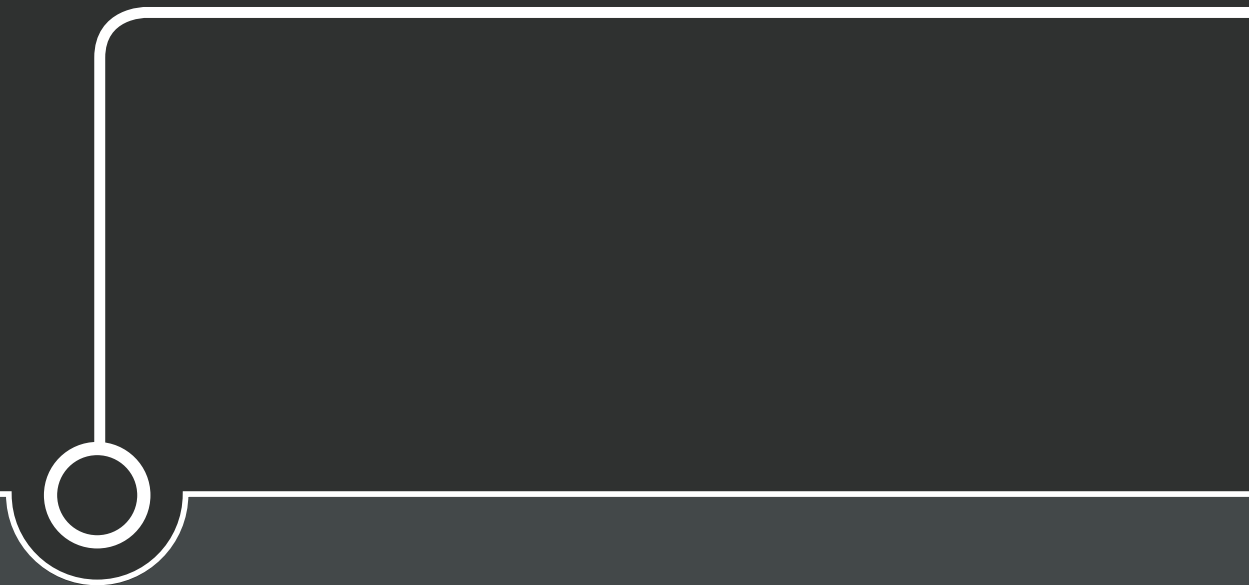

Figure 23. CVU200, locations of the valve connections.

No POWER like it.



Black Bruin Inc.

+358 20 755 0755
P.O. Box 633, FI-40101 JYVÄSKYLÄ, FINLAND

www.blackbruin.com
info@blackbruin.com

All the information contained in this publication is based on the latest information available at the time of publication. Black Bruin Inc. reserves the right to make changes without prior notice.