

# Black Bruin



**Product Manual**  
**S series**

# Contents

<b>1</b>	<b>General Instructions.....</b>	<b>4</b>
1.1	About the manual.....	4
1.2	Intended use.....	4
1.3	Warranty.....	4
1.4	Product identification.....	4
1.5	Publication date.....	4
1.6	Declaration of incorporation.....	5
<b>2</b>	<b>Safety Instructions.....</b>	<b>6</b>
2.1	Warning symbols.....	6
<b>3</b>	<b>Motor Description.....</b>	<b>7</b>
3.1	Working principle.....	7
3.2	Product identification code.....	8
3.2.1	Motor model code.....	8
3.2.2	Processing ID.....	9
3.3	Technical data.....	10
3.4	Motor interfaces.....	13
3.4.1	Main dimensions.....	13
3.4.2	Dimensions of the 2-speed motors.....	14
3.4.3	Shaft connection.....	15
3.4.4	Housing interface.....	18
3.4.5	Torque arm.....	18
3.5	Rotating direction.....	19
3.6	Freewheeling function.....	20
3.7	1-speed : 1N00.....	20
3.8	2-speed valve : 2N0R / 2N0L.....	21
3.9	Holding brake.....	22
3.10	Seal protector.....	23
3.11	Flushing of the motor case.....	24
3.12	Accessories.....	24
3.12.1	Speed sensor.....	24
3.12.2	Shrink discs.....	25
<b>4</b>	<b>System Design.....</b>	<b>26</b>
4.1	Motor hydraulic circuit.....	26
4.1.1	Simple connection.....	26
4.1.2	Counter pressure operation.....	26
4.1.3	Hydrostatic braking.....	27
4.1.4	Short circuit operation.....	27
4.2	Hydraulic connections.....	28
4.3	Hydraulic fluid.....	29
4.3.1	Hydraulic fluid type.....	29
4.3.2	Hydraulic fluid properties.....	29
4.3.3	Hydraulic fluid cleanliness.....	30
4.4	Operating pressures.....	30
4.4.1	Case pressure.....	30
4.4.2	Pilot pressure.....	30
4.4.3	Working line pressure.....	30

<b>5</b>	<b>Motor Sizing.....</b>	<b>33</b>
5.1	Performance.....	33
5.1.1	Rotating speed and flow rate.....	33
5.1.2	Torque and power.....	33
5.2	Performance charts.....	34
5.2.1	Performance curves.....	34
5.2.2	Pressure loss.....	37
5.2.3	Case leakage.....	39
5.2.4	Brake torque.....	39
5.3	Service life.....	39
<b>6</b>	<b>Installation Instructions.....</b>	<b>41</b>
6.1	Mounting the motor.....	41
6.2	Flushing the hydraulic system.....	41
6.3	Air bleeding procedure.....	41
6.4	Commissioning procedure.....	42
<b>7</b>	<b>Operating Instructions.....</b>	<b>43</b>
7.1	Break-in period.....	43
7.2	Use.....	43
7.3	Operating temperature.....	43
7.4	Demounting the motor.....	43
<b>8</b>	<b>Special Instructions.....</b>	<b>45</b>
8.1	Storing the motor.....	45

# 1 General Instructions

## 1.1 About the manual

This manual contains the technical instructions for the Black Bruin S series hydraulic motors. Take these instructions into consideration when planning the use of the product.

All information given in this manual is current and valid according to the information available at the time of publication. The manufacturer reserves the rights to implement changes without prior notice.

Please visit [www.blackbruin.com](http://www.blackbruin.com) for the most recent version of this manual. The product datasheets and the 3D-models are available from the manufacturer by request.

## 1.2 Intended use

Black Bruin S series hydraulic motors are designed for industrial use.

## 1.3 Warranty

Check the package and the product for transport damage when receiving goods. The package is not meant for long term storage; protect the product appropriately.

Do not dismantle the product. The warranty is void if the product has been disassembled.

The manufacturer is not responsible for damages resulting from misinterpreted, non-compliance, incorrect, or improper use of the product that goes against the instructions given in this document.

## 1.4 Product identification

The product identification data can be found on the identification plate attached to the motor.



Figure 1. Identification plate of the motor.



### Note:

The serial number is also stamped on the motor. All manufacturing data can be found with the serial number.

## 1.5 Publication date

10.06.2019 - This manual is published.

## 1.6

## Declaration of incorporation

<b>Black Bruin</b>	DECLARATION OF INCORPORATION 1(1)
	2017-09-27
Black Bruin Inc.	
<b>DECLARATION OF INCORPORATION</b> (in accordance with EC Machinery Directive 2006/42/EC, Annex II B)	
Manufacturer	Black Bruin Inc.
Address	Valmetintie 9 FI-40420 Jyskä, FINLAND
Product description	Black Bruin hydraulic motor series: <ul style="list-style-type: none"> <li>▪ <b>BBC</b></li> <li>▪ <b>BB</b></li> <li>▪ <b>B200</b></li> <li>▪ <b>S</b></li> </ul> <p>We hereby declare that the product(s) specified above is intended to be incorporated into machinery or to be assembled with other machinery to constitute machinery covered by EC Machinery Directive 2006/42/EC, as amended.</p> <p>And that the following harmonised standards have been applied:</p> <ul style="list-style-type: none"> <li>▪ <b>EN ISO 4413:2010</b> (Hydraulic fluid power - General rules and safety requirements for systems and their components)</li> <li>▪ <b>EN ISO 12100:2010</b> (Safety of machinery – General principles for design – Risk assessment and risk reduction)</li> </ul> <p>And furthermore declares that the product(s) covered by this declaration must not be put into service until the final machinery into which it is to be incorporated has been declared in conformity with the provisions of EC Machinery Directive 2006/42/EC.</p> <p>The product(s) must be applied and installed in accordance with all the technical documents applicable to the product(s).</p> <p>This document supersedes all previous releases to this subject.</p>
Place and date	Jyväskylä, 2017-09-27
	On behalf of Black Bruin Inc.
	
Name	Seppo Koiranen
Title	Technical Director
<hr style="border: 0.5px solid red;"/> <p>BLACK BRUIN INC. P.O. Box 633, FI-40101 JYVÄSKYLÄ, FINLAND +358 20 755 0755   info@blackbruin.com   www.blackbruin.com</p>	

## 2 Safety Instructions

The following instructions apply to all procedures associated with the motor. Read these instructions carefully and follow them closely.

- Use necessary personal protective equipment when working with the motor.
- Support the motor properly. Make sure the motor cannot fall over or turn around by accident.
- Use only appropriate equipment and attachments for lifting and transferring the motor.
- Do not use magnetic lifting devices.
- Always use the lifting equipment properly and check the load-bearing capacity.
- Prevent unintended use of the motor during installation and maintenance procedures by preventing pressurization of the hydraulic lines.
- The operating temperature of the motor may be over 60 °C (140 °F), which is hot enough to cause severe burns. Beware of hot hydraulic fluid when disconnecting the hydraulic connections.

### 2.1 Warning symbols

The following symbols are used in this manual:



**Note:**

Useful information.



**Danger:**

Danger of death or injury.



**Attention:**

May cause damage to the product.

## 3 Motor Description

### 3.1 Working principle

S series motors are rotating shaft motors. This means the motor shaft and the cylinder block rotates while the motor is running.

S series motors can be equipped with a holding brake.

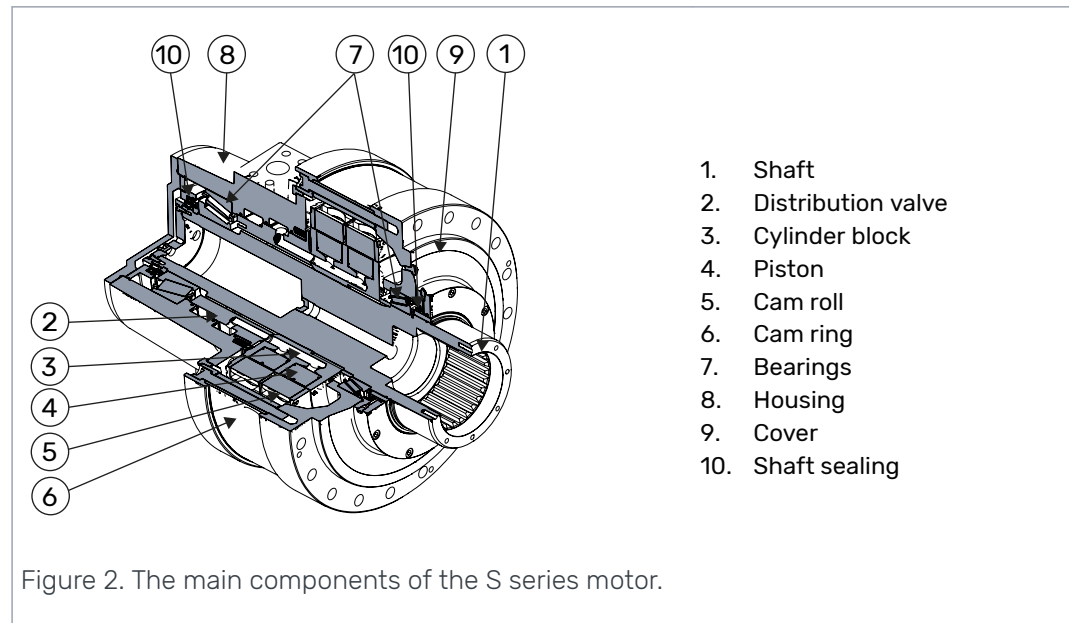

The rotation of the motor is achieved by feeding pressurized hydraulic fluid through the working lines to the distribution valve. The distribution valve directs the flow to the pistons which are on a power stroke. Pressure pushes the pistons and cam rolls outwards against the cam ring on the housing. The waveform of the cam ring transforms the force into torque. When the pistons reach the end of the power stroke, the distribution valve closes the flow to the pistons and switches the pistons to a return stroke. The cam ring pushes the pistons back into the cylinder block preparing them for the next outward power stroke.

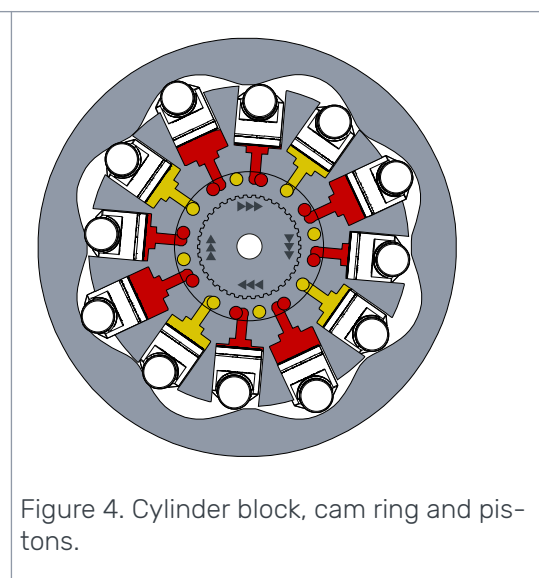
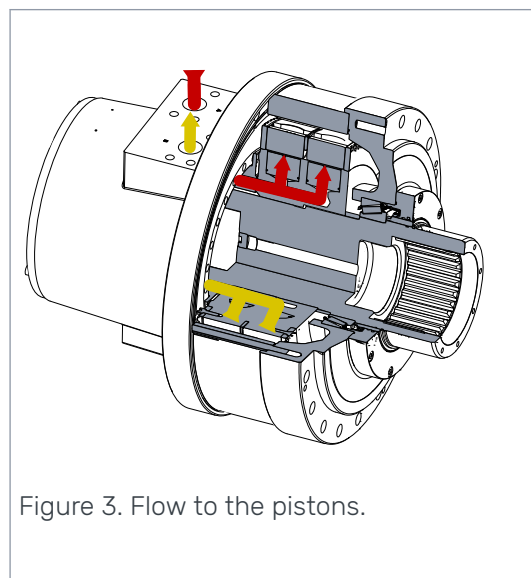

### 3.2 Product identification code

Black Bruin product identification code consists of motor model code and processing ID.

<b>S2100-1000-2NOL-4A-0</b>	-	<b>110000</b>
Motor model code	-	Processing ID

#### 3.2.1 Motor model code

<b>MODEL CODE</b>	<b>AAAAA - BBBB - CCCC - DD - E</b>
Rotating shaft motors	

<b>A: Frame</b>	<b>AAAAA-BBBB-CCCC-DD-E</b>	<b>S1000</b>	<b>S2000</b>	<b>S3000</b>
S series frames	<u>S1000</u>	•		
	<u>S2000</u>		•	
	<u>S3000</u>			•

<b>B: Displacement</b>	<b>AAAAA-BBBB-CCCC-DD-E</b>	<b>S1000</b>	<b>S2000</b>	<b>S3000</b>
S1000 displacements	<u>0440</u> : 4400 ccm/rev	•		
	<u>0630</u> : 6300 ccm/rev	•		
S2000 displacements	<u>0880</u> : 8800 ccm/rev		•	
	<u>1000</u> : 10000 ccm/rev		•	
	<u>1260</u> : 12600 ccm/rev		•	
S3000 displacements	<u>1500</u> : 15000 ccm/rev			•
	<u>1890</u> : 18900 ccm/rev			•

<b>C: Displacement control</b>	<b>AAAAA-BBBB-CCCC-DD-E</b>	<b>S1000</b>	<b>S2000</b>	<b>S3000</b>
1-speed	<u>1N00</u> : Fixed displacement	•	•	•
2-speed valve	<u>2N0R</u> : Right side - CW preferred	•	•	•
	<u>2N0L</u> : Left side - CCW preferred	•	•	•

<b>D: Shaft type</b>	<b>AAAAA-BBBB-CCCC-DD-E</b>	<b>S1000</b>	<b>S2000</b>	<b>S3000</b>
Internal splines	<u>1A</u> : DIN5480-N140	•		
	<u>1B</u> : DIN5480-N140		•	
	<u>1C</u> : DIN5480-N150		•	•
	<u>1D</u> : DIN5480-N150		•	•
Internal splines, through shaft	<u>2A</u> : DIN5480-N150		•	•
External splines, through shaft	<u>3A</u> : DIN5480-W150		•	
	<u>3B</u> : DIN5480-W180			•
External splines, solid shaft	<u>4A</u> : DIN5480-W150		•	•
	<u>4B</u> : DIN5480-W180			•
Shrink disc	<u>5A</u>		•	•



<b>E: Housing type</b>	<b>AAAAA-BBBB-CCCC-DD-E</b>	<b>S1000</b>	<b>S2000</b>	<b>S3000</b>
Mounting threads	<u>0</u> : M24 threads (standard)	•	•	•
	<u>1</u> : 1-8 UNC threads	○	○	○

<b>MODEL CODE</b>	<b>AAAAA - BBBB - CCCC - DD - E</b>
Rotating shaft motors with brake	

<b>A: Frame</b>	<b>AAAAA-BBBB-CCCC-DD-E</b>	<b>S1100</b>	<b>S2100</b>	<b>S3100</b>
S series frames	<u>S1100</u>	•		
	<u>S2100</u>		•	
	<u>S3100</u>			•

<b>B: Displacement</b>	<b>AAAAA-BBBB-CCCC-DD-E</b>	<b>S1100</b>	<b>S2100</b>	<b>S3100</b>
S1100 displacements	<u>0440</u> : 4400 ccm/rev	•		
	<u>0630</u> : 6300 ccm/rev	•		
S2100 displacements	<u>0880</u> : 8800 ccm/rev		•	
	<u>1000</u> : 10000 ccm/rev		•	
	<u>1260</u> : 12600 ccm/rev		•	
S3100 displacements	<u>1500</u> : 15000 ccm/rev			•
	<u>1890</u> : 18900 ccm/rev			•

<b>C: Displacement control</b>	<b>AAAAA-BBBB-CCCC-DD-E</b>	<b>S1100</b>	<b>S2100</b>	<b>S3100</b>
1-speed	<u>1N00</u> : Fixed displacement	•	•	•
2-speed valve	<u>2NOR</u> : Right side - CW preferred	•	•	•
	<u>2NOL</u> : Left side - CCW preferred	•	•	•

<b>D: Shaft type</b>	<b>AAAAA-BBBB-CCCC-DD-E</b>	<b>S1100</b>	<b>S2100</b>	<b>S3100</b>
External splines, solid shaft	<u>4A</u> : DIN5480-W150	•	•	•

<b>E: Housing type</b>	<b>AAAAA-BBBB-CCCC-DD-E</b>	<b>S1100</b>	<b>S2100</b>	<b>S3100</b>
Mounting threads	<u>0</u> : M24 threads (standard)	•	•	•
	<u>1</u> : 1-8 UNC threads	○	○	○

<b>Code example</b>	<b><u>S2100</u> - <u>1000</u> - <u>2NOL</u> - <u>4A</u> - <u>0</u></b>
	<b>A - B - C - D - E</b>
A =	The frame of the motor is "S2100".
B =	The displacement of the motor is 10000 ccm/rev.
C =	In-built 2-speed valve for displacement control. The motor is CCW preferred in 2-speed mode.
D =	The shaft of the motor is solid and it has external splines. Spline type W150.
E =	The thread type for the mounting holes in the housing is M24.

### 3.2.2

### Processing ID

<b>S SERIES PROCESSING ID</b>	<b>R M S P D T</b>
-------------------------------	--------------------

## Motor Description

<b>R M S P D T</b>	<b>Lubrication</b>	<b>Definition of factory lubrication</b>
0	= Seal protector is not filled with lubricant. <sup>1)</sup>	
1	= Seal protector is filled with lubricant.	

<b>R M S P D T</b>	<b>Painting</b>	<b>Definition of the painted surfaces</b>
0	= No painting	- Motors are washed and protected from corrosion.
1	= Painted	- <sup>2)</sup>

<b>R M S P D T</b>	<b>Protection</b>	<b>Definition of the protection for storage/transportation</b>
0	= Default / Not defined <sup>3)</sup>	

<b>R M S P D T</b>	<b>Packaging</b>	<b>Definition of the motor package</b>
0	= Default / Not defined <sup>4)</sup>	

<b>R M S P D T</b>	<b>Documents</b>	<b>Definition of the printouts to be attached to the delivery</b>
0	= Default / Not defined	

<b>R M S P D T</b>	<b>Testing</b>	<b>Definition of the testing and reporting</b>
0	= Default / Not defined <sup>5)</sup>	

<b>Code example</b>	<b><u>1</u></b>	<b><u>1</u></b>	<b><u>0</u></b>	<b><u>0</u></b>	<b><u>0</u></b>	<b><u>0</u></b>
	R	M	S	P	D	T
R =	The seal protector of the motor is filled with lubricant.					
M =	Prime coating. The shaft and hub interfaces of the motor are unpainted.					
S =	Pressure openings and threaded holes of the motor are protected according to general practices of the manufacturer.					
P =	The motor is packaged according to general practices of the manufacturer.					
D =	The documentation delivered with the motor is according to general practices of the manufacturer.					
T =	The motor is tested according to general practices of the manufacturer.					

<sup>1)</sup> If necessary, the seal protector is not filled with lubricant at the factory.

<sup>2)</sup> Prime coating: HEMPETHANE HS 55610 or equivalent. Tint: glossy black.

<sup>3)</sup> Working lines are plugged with metal covers. Other pressure openings and threaded holes are capped with plastic fittings. Hydraulic fluid is drained out.

<sup>4)</sup> Delivery on wooden pallet or in plywood box.

<sup>5)</sup> The manufacturer keeps test records of every manufactured motor.

## 3.3

### Technical data

<b>TECHNICAL DATA</b>	<b>S1000</b>		<b>S2000</b>			<b>S3000</b>	
<b>Displacement [ccm]</b>							
at full displacement	4400	6300	8800	10000	12600	15000	18900

<b>TECHNICAL DATA</b>	<b>S1000</b>	<b>S2000</b>	<b>S3000</b>
at half displacement	2200 3150	4400 5000 6300	7500 9450
<b>Maximum torque [Nm]</b>			
theoretical	31500 45100	63000 71600 90200	107400 135300
with 100 bar	7000 10000	14000 15900 20000	23900 30000
<b>Max. operating power [kW]</b>			
at full displacement	175	350	500
at half displacement	118	235	335
<b>Max. rotating speed [rpm]</b>			
at full displacement	180	130 110 90	75 60
at half displacement	180	130 110 90	75 60
at freewheeling	180	180	180
<b>Min. rotating speed [rpm]</b>	3 <sup>2)</sup>	3 <sup>2)</sup>	3 <sup>2)</sup>
<b>Max. working pressure [bar]</b>			
peak pressure	450	450	450
intermittent <sup>1)</sup>	400	400	400
<b>Max. case pressure [bar]</b>			
average	2	2	2
intermittent <sup>1)</sup>	10	10	10
<b>Flushing flow [l/min]</b>			
recommended	3,8 - 5,7	5,7 - 7,6	7,6 - 9,5
maximum	15	15	15
<b>Recommended pilot pressures for 2-speed valve [bar]</b>			
at full displacement Y1	0 - 2	0 - 2	0 - 2
Y2	0 - 50	0 - 50	0 - 50
at half displacement Y1	10 - 20	10 - 20	10 - 20
Y2	0 - 2	0 - 2	0 - 2
<b>Weight [kg]</b>	430 - 448	540 - 618	642 - 734

<b>TECHNICAL DATA</b>	<b>S1100</b>	<b>S2100</b>	<b>S3100</b>
<b>Displacement [ccm]</b>			
at full displacement	4400 6300	8800 10000 12600	15000 18900
at half displacement	2200 3150	4400 5000 6300	7500 9450
<b>Maximum torque [Nm]</b>			
theoretical	31500 45100	63000 71600 90200	107400 135300
with 100 bar	7000 10000	14000 15900 20000	23900 30000
<b>Brake torque [Nm]</b>	55000	95000	95000
<b>Max. operating power [kW]</b>			
at full displacement	175	350	500
at half displacement	118	235	335
<b>Max. rotating speed [rpm]</b>			

## Motor Description

<b>TECHNICAL DATA</b>	<b>S1100</b>	<b>S2100</b>	<b>S3100</b>
at full displacement	180	130 110 90	75 60
at half displacement	180	130 110 90	75 60
at freewheeling	180	180	180
<b>Min. rotating speed [rpm]</b>	3 <sup>2)</sup>	3 <sup>2)</sup>	3 <sup>2)</sup>
<b>Max. working pressure [bar]</b>			
peak pressure	450	450	450
intermittent <sup>1)</sup>	400	400	400
<b>Max. case pressure [bar]</b>			
average	2	2	2
intermittent <sup>1)</sup>	10	10	10
<b>Flushing flow [l/min]</b>			
recommended	3,8 - 5,7	5,7 - 7,6	7,6 - 9,5
maximum	15	15	15
<b>Recommended pilot pressures for 2-speed valve [bar]</b>			
at full displacement Y1	0 - 2	0 - 2	0 - 2
Y2	0 - 50	0 - 50	0 - 50
at half displacement Y1	10 - 20	10 - 20	10 - 20
Y2	0 - 2	0 - 2	0 - 2
<b>Brake opening pressure [bar]</b>			
minimum	20	20	20
maximum	30	30	30
<b>Max. brake releasing displacement [ccm]</b>	1000	1000	1000
<b>Brake opening pressure leakage [l/min]</b>	< 0,1	< 0,1	< 0,1
<b>Weight [kg]</b>	748 - 766	850 - 868	957 - 975

<sup>1)</sup> Intermittent operation: permissible values for maximum of 10% of every minute.

<sup>2)</sup> Special consideration of the work pressure and the oil properties under 3 rpm is necessary.

### 3.4 Motor interfaces

#### 3.4.1 Main dimensions

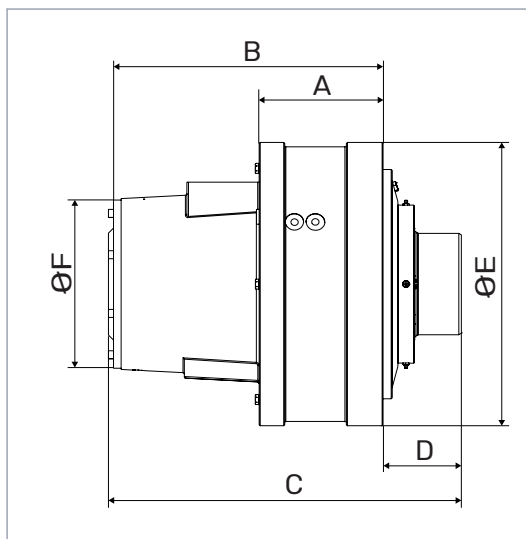

Figure 5. Shaft types 1A, 1B, 1C, 1D, 4A, 4B and 5A.

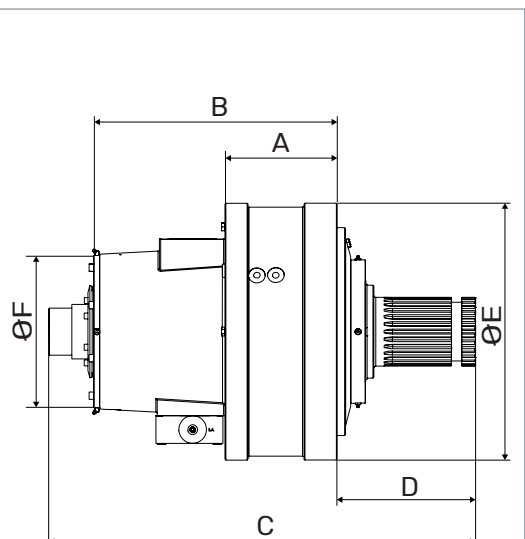
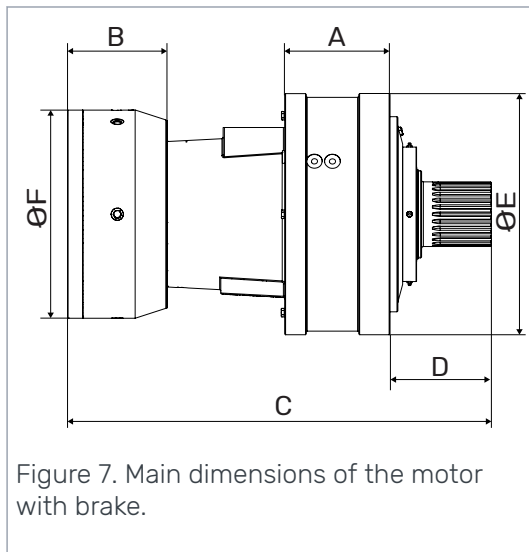

Figure 6. Shaft types 2A, 3A and 3B.

MOTOR TYPE	SHAFT TYPE	MAIN DIMENSIONS [mm]					
		A	B	C	D	E	F
S1000	1A	172	458	552	84	556	330
	1B	243	529	693	154	556	330
	1C	243	529	693	154	556	330
	1D	243	529	740	201	556	330
S2000	2A	243	529	702	154	556	330
	3A	243	529	924	299,5	556	330
	4A	243	529	773	234	556	330
	5A	243	529	769	230	556	330
S3000	1C	314	600	764	154	556	330
	1D	314	600	811	201	556	330
	2A	314	600	773	154	556	330
	3B	314	600	995	299,5	556	330
	4A	314	600	844	234	556	330
	4B	314	600	844	234	556	330
	5A	314	600	840	230	556	330

## Motor Description



MOTOR TYPE	SHAFT TYPE	MAIN DIMENSIONS [mm]					
		A	B	C	D	E	F
S1100	4A	172	230	907	234	556	480
S2100	4A	243	230	978	234	556	480
S3100	4A	314	230	1049	234	556	480

### 3.4.2

#### Dimensions of the 2-speed motors

The 2-speed valve increases the main dimensions of the S series motors.

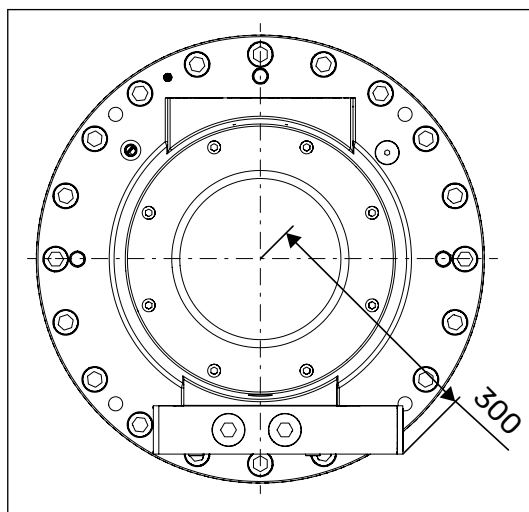
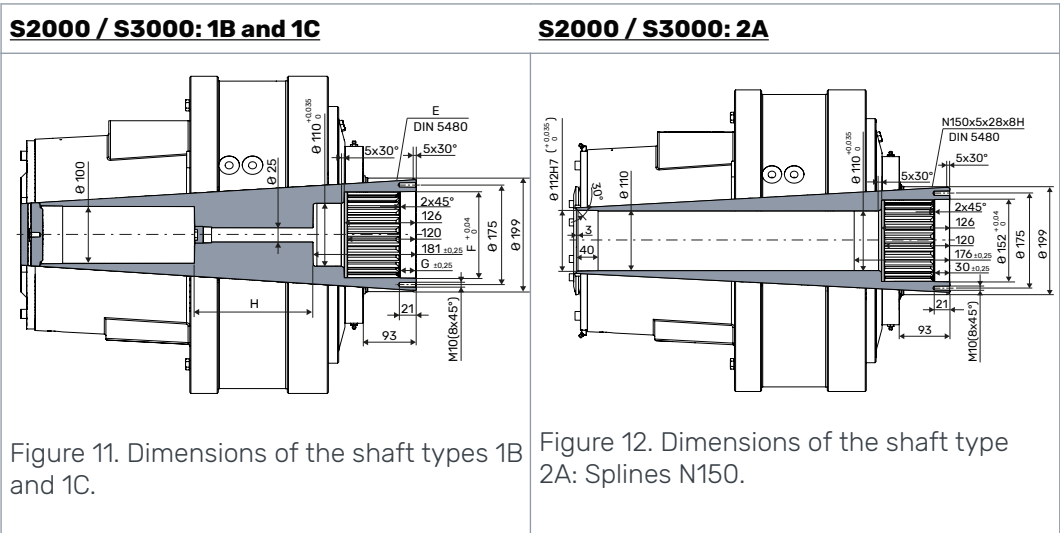
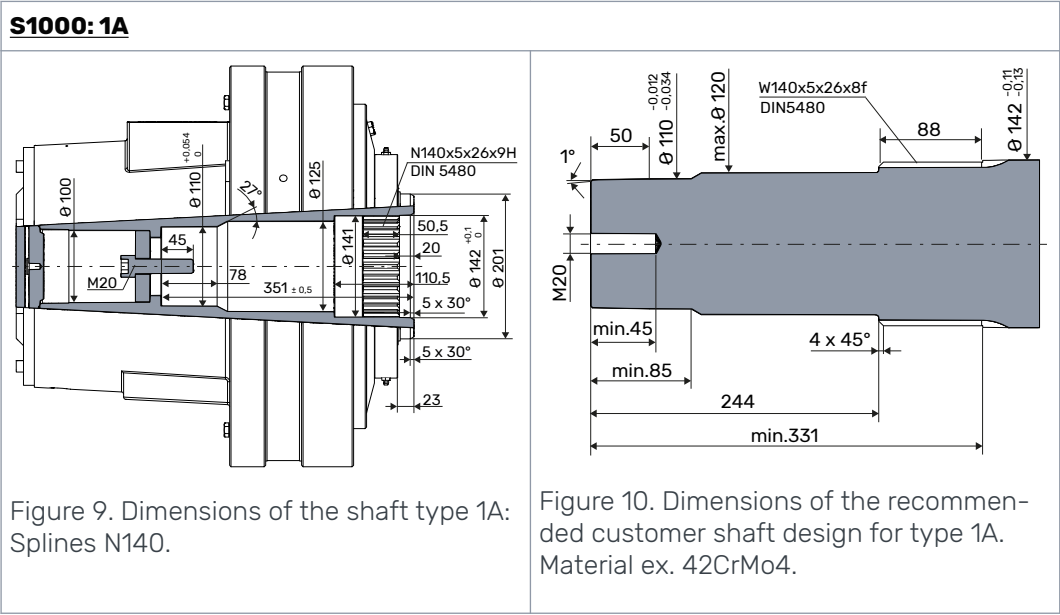
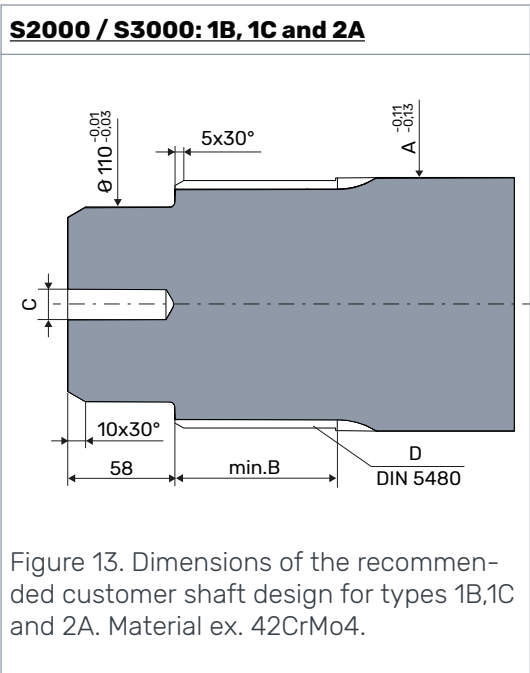

Figure 8. Dimensioning of the 2-speed valve.

**3.4.3 Shaft connection**





		<b>1B</b>	<b>1C,2A</b>
A	[mm]	$\varnothing 142$	$\varnothing 152$
B min (spline length)	[mm]	89	99
C		Threaded hole for mounting bolt	
D	[mm]	W140x5x26x8f	W150x5x28x8f
E	[mm]	N140x5x26x9H	N150x5x28x8H
F	[mm]	$\varnothing 142$	$\varnothing 152$
G	[mm]	40	30
H	[mm]	207,5	207,5 (S2000) 278,5 (S3000)

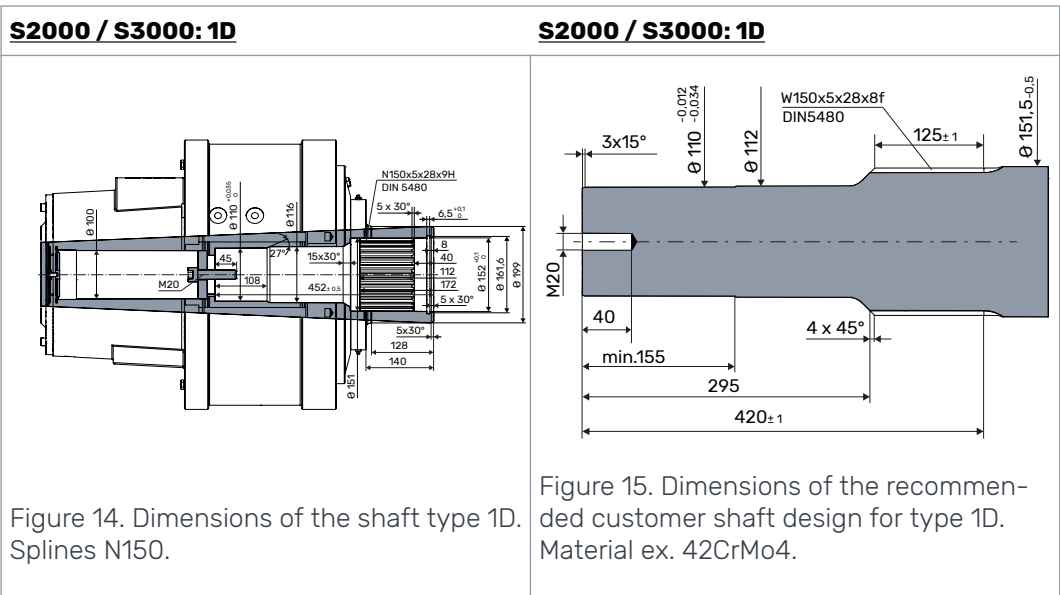



**S2000: 3A**

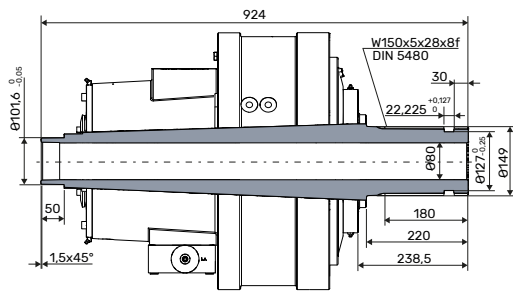

Figure 16. Dimensions of the shaft type 3A, through splines W150.

**S2000 / S3000: 4A, 4B**

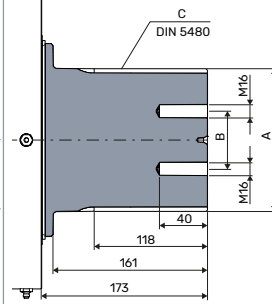

Figure 17. Dimensions of the shaft types 4A and 4B. Solid shaft W150 / W180.

		<b>S2000 / S3000: 4A</b>	<b>S3000: 4B</b>
A	[mm]	$\varnothing 149$	$\varnothing 179$
B	[mm]	60	90
C	[mm]	W150x5x28x8f	W180x5x34x8f

**S3000: 3B**

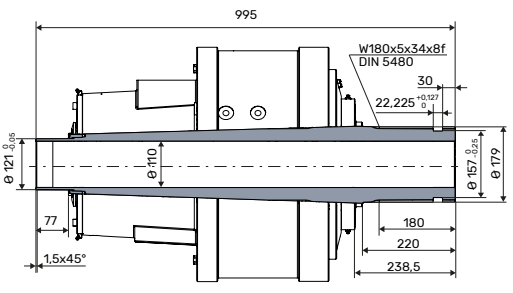

Figure 18. Dimensions of the shaft type 3B, through splines W180.

**S2000 / S3000: 5A**

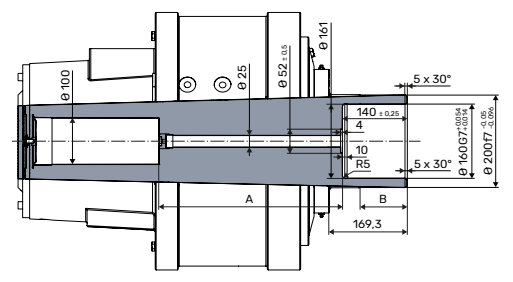

Figure 19. Dimensions of the shaft type 5A, shrink disc.

**S2000 / S3000: 5A**

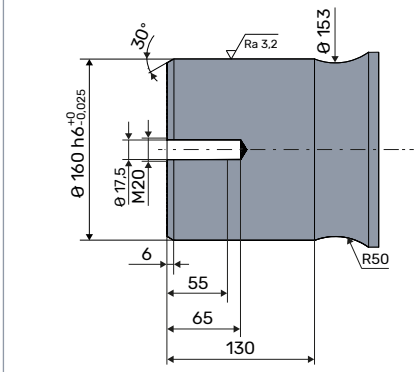

Figure 20. Dimensions of the recommended customer shaft design for type 5A. Material ex. 42CrMo4.

		<b>S2000: 5A</b>	<b>S3000: 5A</b>
A	[mm]	325,15	396,15
B	[mm]	102	123

### 3.4.4 Housing interface

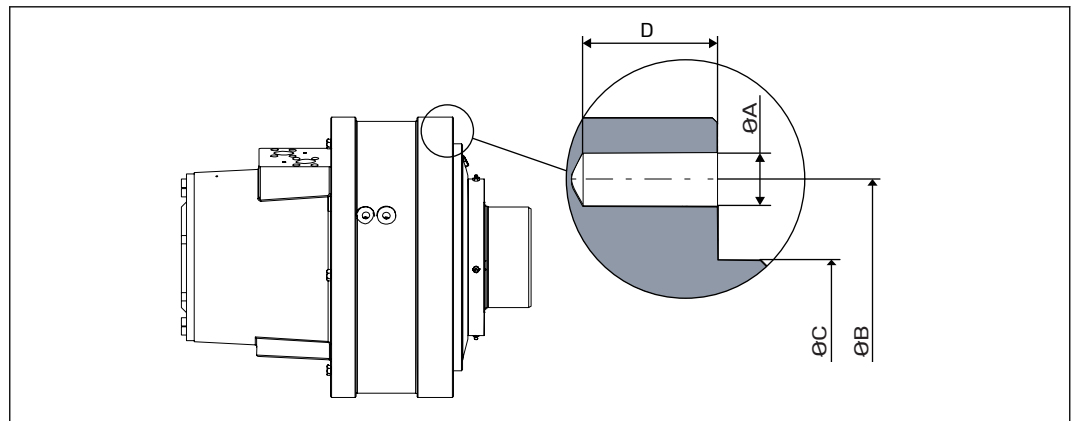

Figure 21. Dimensions of the housing interface.

<b>INTERFACE DIMENSIONS</b>		
<b>Housing interface</b>		
A	size	M24 <sup>1)</sup>
	pattern	20x18°
	strength class <sup>2)</sup>	10,9
	tightening torque <sup>3)</sup> [Nm]	930
B	[mm]	510
C	[mm]	450
	tolerance [mm]	0 / -0,15
D	(thread) [mm]	45

<sup>1)</sup> M24 thread can be replaced with UNC 1"-8 thread, see model code E.

<sup>2)</sup> Strength class as in ISO898-1. If using lower strength class, check interface load capacity and tightening torque.

<sup>3)</sup> Declared values are for reference only. Always use application specific tightening torques when given.



**Note:**

The attachment screws are not included in the motor delivery. Ensure correct dimensioning and availability of the fastening screws.

### 3.4.5 Torque arm

The motor can be mounted to the application with the torque arm.

The length of the torque arm affects the radial force applied to the motor and thus the service lifetime of the bearings.

Shaft types used for torque arm mounting; 1A, 1B, 1C, 1D, 2A and 5A. For torque arm mounting, the splines of the shaft connection must be greased or in oil.

When using a double ended torque arm there would not be a radial load applied to the motor due the torque.

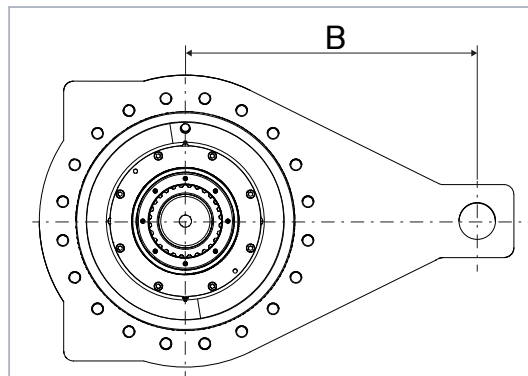

Figure 22. Torque arm length.

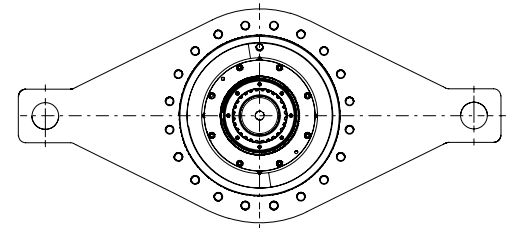

Figure 23. Double ended torque arm.

The minimum length of the torque arm, B:

S1000	=	600 mm
S2000	=	800 mm
S3000	=	1000 mm

### 3.5 Rotating direction

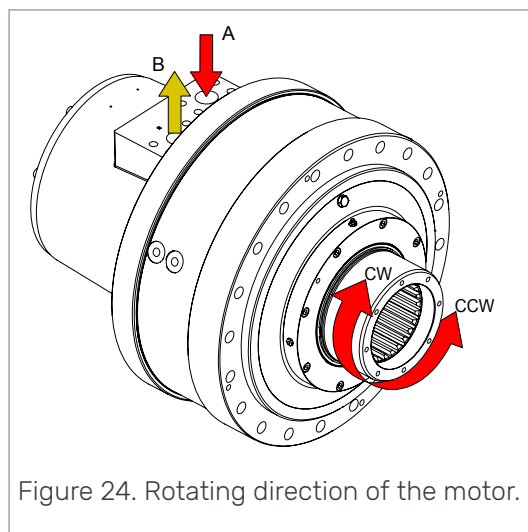

Figure 24. Rotating direction of the motor.

The rotating direction of the motor is defined as the rotating direction of the shaft viewed from the front of the motor.

The rotating direction of the motor and the flow direction in the working lines is given in the table below.

Table 1: Rotating direction and flow direction.

ROTATING DIRECTION	Flow direction	
	A → B	B → A
1N00	CW	CCW
2N0R	CW	CCW
2N0L	CCW	CW

### Preferred operating direction

AAAAA	-	BBBB	-	<b>2NOR</b>	-	DD	-	E
AAAAA	-	BBBB	-	<b>2NOL</b>	-	DD	-	E

The preferred operating direction applies to motors with 2-speed valve block (see [2-speed valve : 2NOR / 2NOL](#) on page 21).

The preferred operating direction is the rotating direction of the motor when the flow direction is from port A to B.

- **2NOR** = CW motor.
- **2NOL** = CCW motor.

## 3.6 Freewheeling function

Freewheeling of the S series motors can be done by pressurizing the casing, when the case pressure pushes the pistons into the cylinder block. The case pressure must be at least 0.5 bar higher than the pressure on the working lines (A and B). The maximum case pressure must not be exceeded. The permissible freewheeling speed and the maximum case pressure can be found in the technical data (see [Technical data](#) on page 10).



### Attention:

Any pressure in the working lines (A and B) or loss of case pressure during the freewheeling pushes the pistons out of the freewheeling position. This causes clattering noise when the pistons connect to the cam ring.

Constant clattering of the pistons may cause premature wear or failure of the motor.

### ENGAGING THE MOTOR

Make sure that the motor is not running when engaging the motor. When engaging the motor, the pressure in the working lines must be less than 100 bar to prevent excessive pressure peak in casing, which may damage the shaft seals.

## 3.7 1-speed : 1N00

AAAAA	-	BBBB	-	<b>1N00</b>	-	DD	-	E
-------	---	------	---	-------------	---	----	---	---

Displacement control selection 1-speed means the motor has a fixed displacement. These motors are known as 1-speed motors and are always in full displacement during operation.

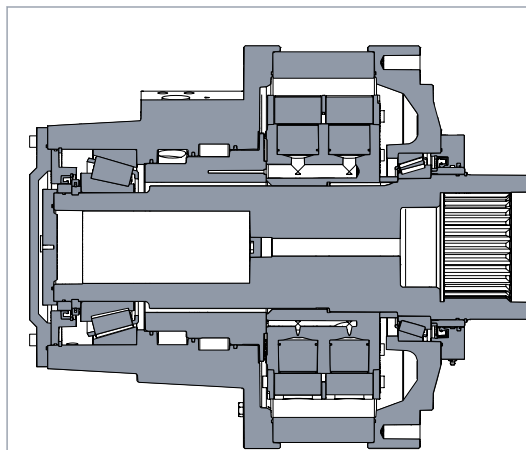

Figure 25. 1-speed motor.

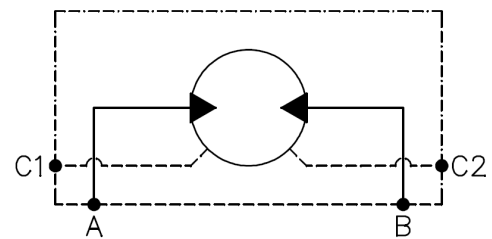

Figure 26. Hydraulic circuit, 1-speed motor.

### 3.8

### 2-speed valve : 2NOR / 2NOL

AAAAA - BBBB - **2NOR** - DD - E  
 AAAAA - BBBB - **2NOL** - DD - E

The 2-speed valve enables change of displacement during operation. The benefit of this function is a more extensive speed range with the same hydraulic system capacity. The motors are also known as 2-speed motors.

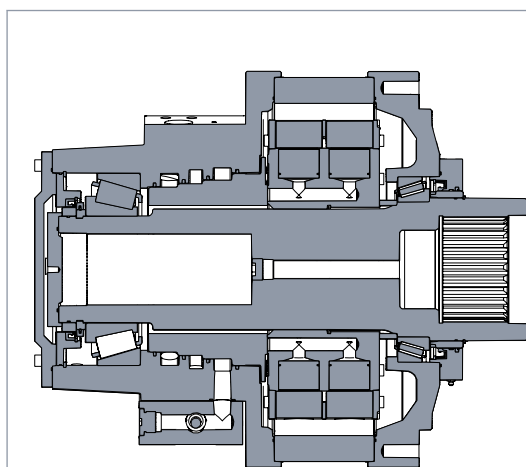

Figure 27. 2-speed motor.

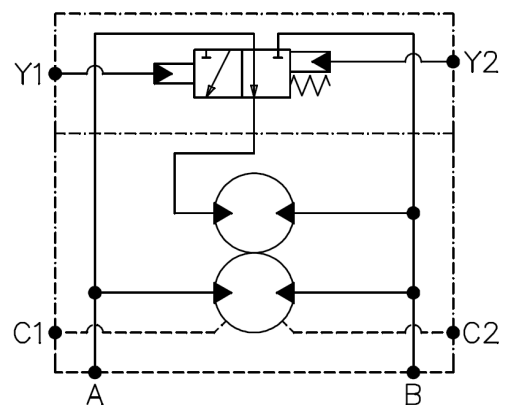

Figure 28. Hydraulic circuit, 2-speed motor.

The change of displacement works by switching the piston to idle on every second stroke. This is done with the in-built 2-speed valve, which changes the fluid circulation in the motor.

#### USING THE 2-SPEED VALVE

Using the 2-speed valve works in the same manner as gear shifting.

- SHIFTING TO HALF DISPLACEMENT

The motor is switched to half displacement by applying the pilot pressure (see [Pilot pressure](#) on page 30) to the pilot line Y1.

## Motor Description

The recommended pressure difference over the pilot lines Y1 and Y2 is 20 bar.

When the motor is not rotated, pressure difference of 10 bar is enough to engage the 2-speed valve.

When the motor operates at half displacement, it rotates twice as fast and generates half of the torque when compared to a motor on full displacement with the same flow rate and pressure.

The working pressure should be primarily applied into the working line A. The motor operates at lower efficiency and the operating temperature may rise if working pressure is applied into the working line B. The motor starting may also be blocked.

- **SHIFTING TO FULL DISPLACEMENT**

The motor is switched back to full displacement by releasing the pressure in the pilot line Y1.

When switching to full displacement during operation, it is recommended to engage the pilot pressure to pilot line Y2 at the same time as the pressure is released from pilot line Y1.

The required pressure difference over the pilot lines Y2 and Y1 can be up to 50 bar depending on the flow rate of the working lines and the hydraulic fluid viscosity.

When switching to full displacement while the motor is stopped, the switching can be done by releasing the pilot pressure from the pilot line Y1. In this case the pilot line Y2 can be connected directly to the drain line.

When the motor operates at full displacement, it works like the 1-speed motor and it may be operated normally on both directions.



**Attention:**

Take the following things into consideration, when changing the speed range during motion.

- Hydraulic system supply must adjust to the rapid change of flow rate.
- The rapid change in flow rate may cause momentary jerk. This may be avoided by throttling the working lines lightly.
- Prevent operating conditions, in which the permissible performance values could be exceeded.

The permissible performance values are in the technical data (see [Technical data](#) on page 10).



**Attention:**

Continuous use of high working pressure in the working line B at half displacement may cause premature wear or failure of the motor.

## 3.9

### Holding brake

The brake used with the S series motors is static brake. Type of the brake is SAHR (Spring Applied, Hydraulics Release) wet multi-disc brake.

#### Mechanical brake release

- Remove the plug from the center of the brake end.
- Tight the screw (M24) with nut and washer to the bottom of the thread in the piston.

- Then tighten the nut until the motor shaft turns freely, needed torque about 750 Nm.

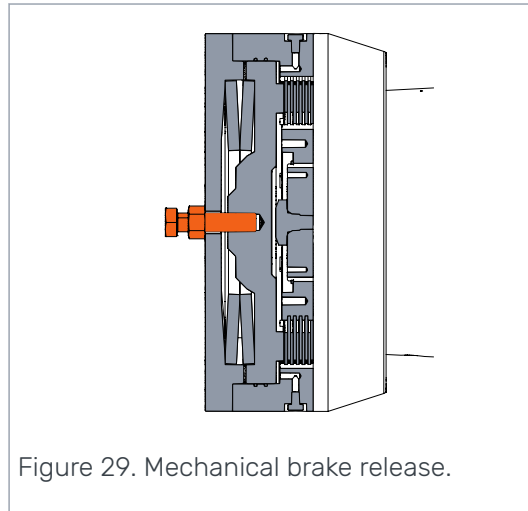

### 3.10 Seal protector

The seal protector is a standard feature of the S series motors.

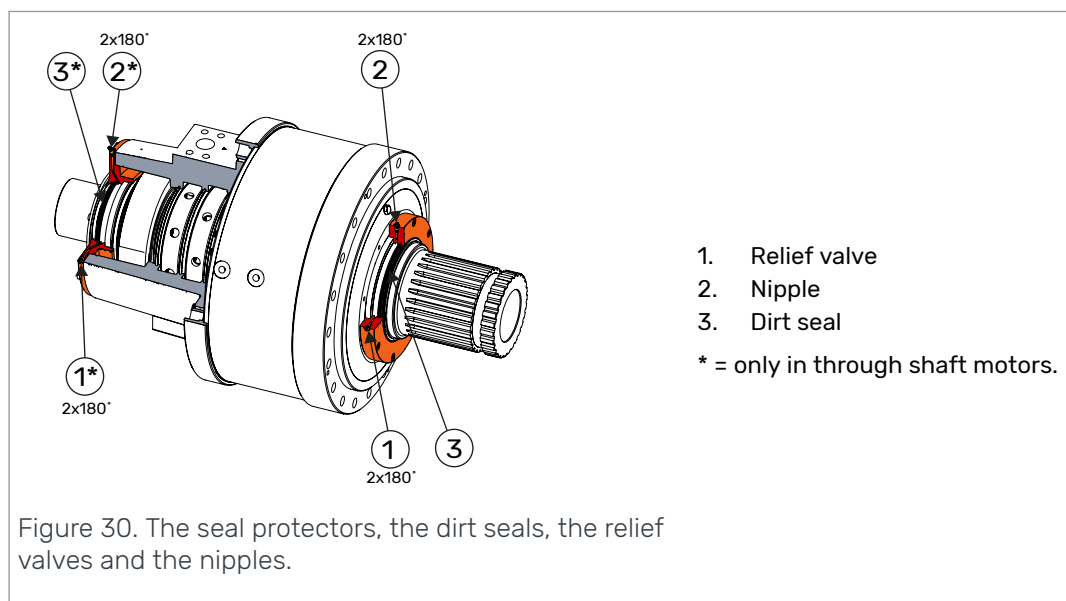

The seal protector prevents dirt and moisture from entering to the motor shaft seal. The operation of the seal protector is based on a sealing lubricant pocket. The seal protector is also known as a grease ring.

#### USING THE SEAL PROTECTOR

The seal protector provides the best protection for the motor when lubricant is added on a regular basis.

- Add lubricant from both nipples during operation. It is recommended to add lubricant when the motor is warm.
- Lubricate the seal protector as part of the machine lubrication routine.
- Observe lubrication adequacy during use and increase or decrease lubrication as needed.

The lubricant pocket is filled with Microlube GL 261 lubricant or equivalent. Use only compatible lubricants. The lubricant is mineral oil-based grease which is precipitated with lithium-soap.

### 3.11 Flushing of the motor case

All the S series motors are equipped with the case flushing line port (C1). The flushing line is an extra case line for cooling the motor.

The motor must be cooled to avoid high temperature in the motor case. High temperature can reduce the performance and the lifetime of the motor.

The motor case must be flushed (see recommended flushing flow rate in *Technical data* on page 10) in all continuous duty applications where the output power is over the 50% of maximum power of the motor. The motor case must be flushed also if in application the motor oil temperature exceed the maximum operating temperature (see *Operating temperature* on page 43).

### 3.12 Accessories

#### 3.12.1 Speed sensor

It is possible to use the speed sensor with all S series motors. The speed sensor and the cable can be ordered separately.

The speed sensor of the S series motors has directional detection and the pulse rate is 100ppr. Technical data of the speed sensor and the cable can be found from the table below.

<b>Sensor model code</b>	SPD
<b>Pulses per revolution</b>	100
<b>Reading range</b>	0,5-2 mm
<b>Supply voltage</b>	8-32 V
<b>Electrical protection</b>	Reverse polarity
<b>Current consumption</b>	20mA max.
<b>Output type</b>	2 push-pull shifted square frequency signals (phase shift minimum 20°)
<b>Frequency range</b>	0 to 15 kHz
<b>Protection rating</b>	IP68
<b>Material</b>	Stainless steel
<b>Cable length</b>	6 m
<b>Cable model code</b>	SPC6
<b>Cable type</b>	Straight: 



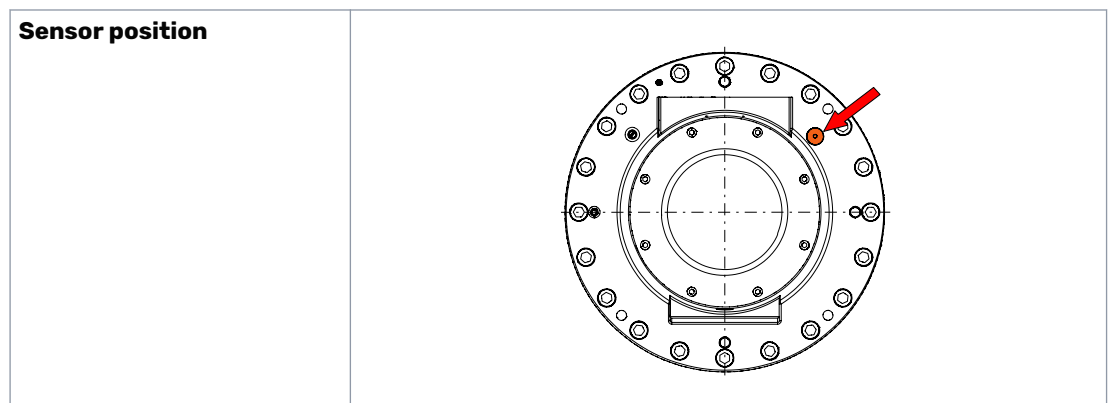

More detailed sensor installation instructions; see the installation manual of the speed sensor.

### 3.12.2

### Shrink discs

These shrink discs are accessories to motors with shaft type 5A.

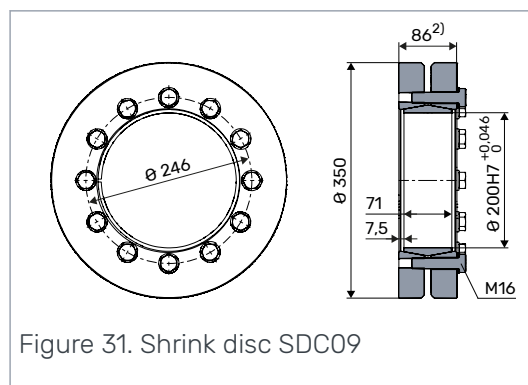

Figure 31. Shrink disc SDC09

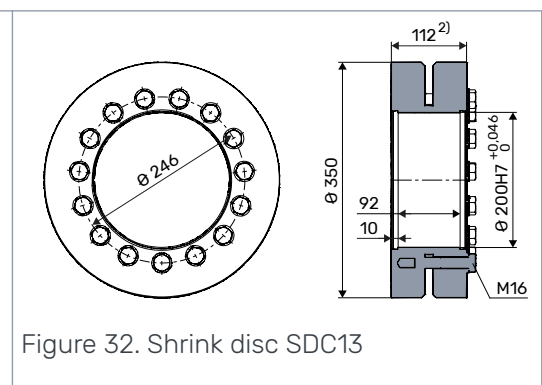

Figure 32. Shrink disc SDC13

		<b>SDC09</b>	<b>SDC13</b>
Locking screws	type	M16 x 70 - strength class 10.9 - DIN 931	M16 x 80 - strength class 12.9 - DIN 931
	amount	12 pcs	15 pcs
	max. torque <sup>1)</sup>	250 Nm	290 Nm
Shrink disc	max. transmittable torque <sup>1)</sup>	88400 Nm	131000 Nm
	weight	39 kg	51 kg
	coating	painted	painted
<sup>1)</sup> Max. transmittable torque is obtained when locking screws are at max. torque.			
<sup>2)</sup> Dimension in unlocked position.			

## 4 System Design

### 4.1 Motor hydraulic circuit

#### 4.1.1 Simple connection

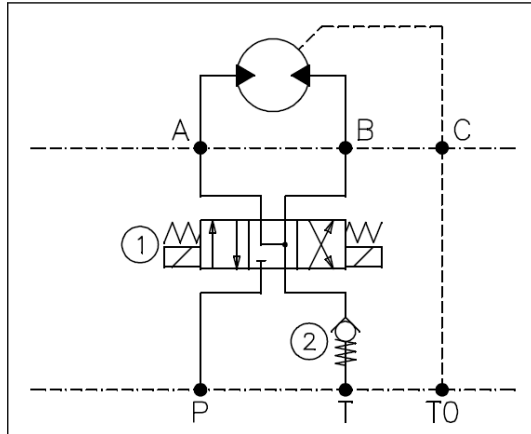

Figure 33. A simple motor hydraulic circuit in an open loop hydraulic system.

In an open loop hydraulic system the hydraulic circuit of the motor is usually implemented roughly as in the figure above.

- Select the operating direction with the directional control valve (1) by applying the working pressure (P) to the other working line (A or B).
- The minimum pressure (see [Working line pressure](#) on page 30) required in the return line (T) is created with the cracking pressure of the check valve (2).
- The case drain line port (C) is connected to the system reservoir (T0) as directly as possible.



**Attention:**

The case drain line of the motor must always be connected to a reservoir, even during freewheeling. The case pressure of the motor may rise significantly, if the motor is completely plugged during use.



**Note:**

Using the motor on a closed loop hydraulic system is different from the open loop system. The closed loop system is more complex, but enables more functions, such as hydrostatic braking, series connection and counter pressure operation.

#### 4.1.2 Counter pressure operation

Counter pressure operation means using the motor with high back pressure in the return line.

The counter pressure operation affects the torque output of the motor due to decreased pressure difference over the working lines.

High counter pressure affects also to the motor efficiency.



**Attention:**

Make sure the combined pressure in the working lines does not exceed the permissible values of the working pressure during counter pressure operation.

Counter pressure operation is not recommended for S series motors, because high back pressure stresses the motor more than usual operation.

### 4.1.3 Hydrostatic braking

Hydrostatic braking means using the output torque of the motor to decelerate the speed. The output torque is generated by closing the return line of the motor, in which case a working pressure will form in the return line. The minimum pressure and feed flow must be maintained in the feed line of the motor during hydrostatic braking.



**Note:**

The hydrostatic braking requires an active hydraulic fluid supply.



**Danger:**

Do not use the hydrostatic braking without relief valves in the working lines. When an external load is rotating the motor, the hydraulic pressure may increase indefinitely. This leads to danger if a hydraulic hose or component brakes under high pressure.

### 4.1.4 Short circuit operation

Short circuit operation means connecting the return flow of the motor directly to the feed line of the motor.

Short circuit operation is needed, if the motor must be rotated faster than the hydraulic system can supply and freewheeling the motor is not possible (see [Freewheeling function](#) on page 20).

Make sure the minimum pressure is maintained in both working lines of the motor during short circuit operation.



**Note:**

The short circuit operation requires an active hydraulic fluid supply.



**Attention:**

Make sure the motor does not overheat during short circuit operation.

## 4.2 Hydraulic connections

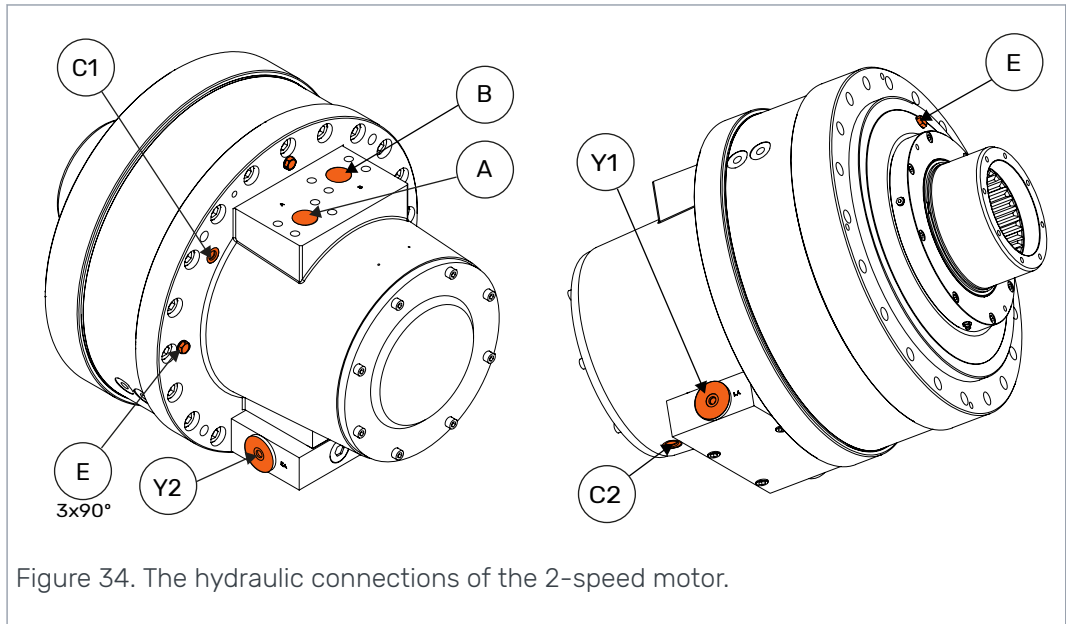

Figure 34. The hydraulic connections of the 2-speed motor.

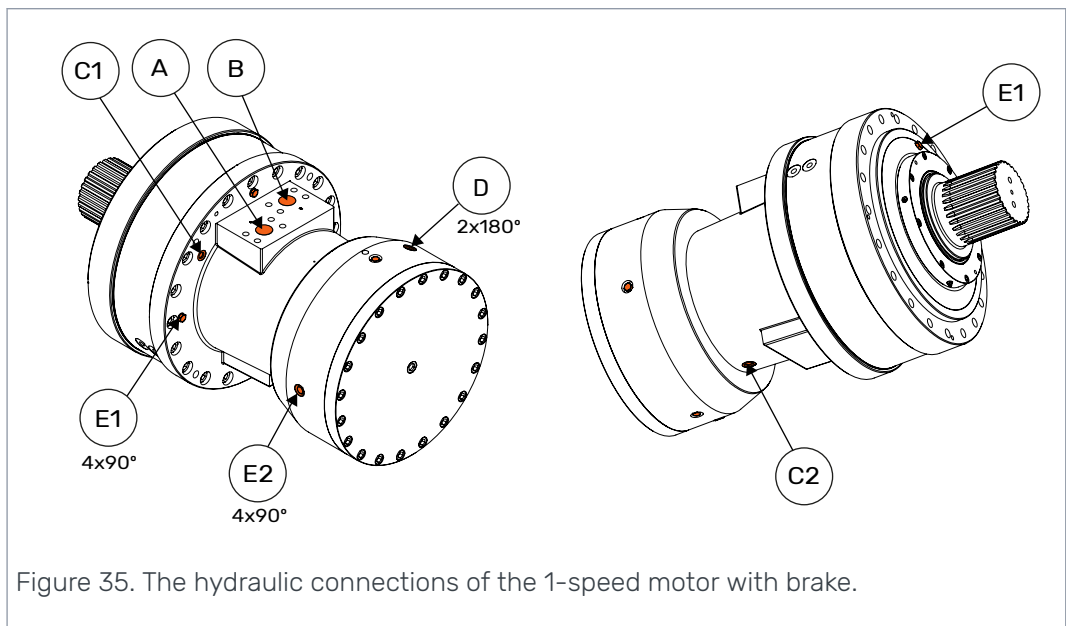

Figure 35. The hydraulic connections of the 1-speed motor with brake.

- **WORKING LINE PORTS (A and B)**  
The working lines, aka the feed and return lines of the motor are the high pressure lines meant for running the motor.
- **FLUSHING LINE PORT (C1)**  
The flushing line is the motor housing flushing inlet line.
- **CASE DRAIN LINE PORT (C2)**  
The case drain line is the return line from the housing cavity.
- **BRAKE LINE PORTS (D)**  
The brake lines are ment for the brake releasing pressure.

There are two ports for the brake so you can choose one of them and plug the other one.

- AIR BLEEDING SCREWS (E/E1)

The air bleed screws are meant for removing the air inside the housing during air bleeding procedure (see [Air bleeding procedure](#) on page 41).

- AIR BLEEDING SCREWS (E2)

The air bleed screws are meant for removing the air inside the brake during air bleeding procedure (see [Air bleeding procedure](#) on page 41).

- PILOT LINE PORTS (Y1 and Y2)

The pilot lines are meant for controlling the 2-speed valve of the motor (see [2-speed valve : 2NOR / 2NOL](#) on page 21).



**Note:**

More detailed information and dimensioning can be found on the product datasheet.

## 4.3 Hydraulic fluid

### 4.3.1 Hydraulic fluid type

Black Bruin hydraulic motors are designed to work with hydraulic fluids based on mineral oil. Consider the following requirements when choosing hydraulic fluid:

- Hydraulic oils in accordance with ISO 6743-4 are recommended to be used.
- Motor oils in accordance with API-grades SF, SG, SH and SL may also be used.
- Fire resistant hydraulic fluids HFB and HFC or similar may be used under certain circumstances.

### 4.3.2 Hydraulic fluid properties

Requirements concerning the hydraulic fluid properties:

- The recommended fluid viscosity range for constant use is 25 - 50 cSt.
- The minimum permissible intermittent viscosity is 15 cSt.
- The maximum permissible viscosity during motor startup is 1000 cSt.
- The viscosity index must be at least 100.
- The water content of hydraulic oil should be less than 500 ppm (0,05 %).
- The hydraulic fluid must reach score 10 on a wear protection test FZG A/8,3/90 in accordance with ISO 14635-1 (DIN 51354)
- The effect of the additives improving the viscosity index can decrease during operation.



**Note:**

Temperature has a significant effect on the viscosity and the lubricating capability of the hydraulic fluid. Take into consideration the real operating temperature when defining the fluid viscosity.

The need for service and the overall service life may be improved by using hydraulic fluids with higher viscosity. In addition higher viscosity may improve the running smoothness.

### 4.3.3 Hydraulic fluid cleanliness

Hydraulic fluid must fulfill cleanliness level 18/16/13 in accordance with ISO 4406 (NAS 1638 grade 7).



**Note:**

The purity of the hydraulic fluid has a significant effect on the need for service and the overall service life of the motor.

## 4.4 Operating pressures

### 4.4.1 Case pressure

The case pressure of the motor affects the lifetime of the sealing. It is recommended to maintain as low case pressure as possible.

When the motor is running, the permissible average case pressure is 2 bar and the highest permissible intermittent case pressure is 10 bar.

When the motor is not running, the highest permissible constant case pressure is 10 bar.



**Attention:**

Running the motor with higher than allowed case pressure shortens the service life of the motor.



**Note:**

The lifetime of the sealing may be improved with an accumulator, which cuts the pressure peaks that are higher than the pre-charge pressure of the accumulator.

Recommended pre-charge pressure is 2 bar and the displacement should be about 25 % of the motor displacement. The accumulator should be connected to the case drain line port as close to the motor as possible.

### 4.4.2 Pilot pressure

AAAAA	-	BBBB	-	<b>2NOR</b>	-	DD	-	E
AAAAA	-	BBBB	-	<b>2NOL</b>	-	DD	-	E

The pilot pressure is used to engage the 2-speed function of the motor and it may be applied to pilot lines Y1 and Y2.

The recommended pilot pressure is 20 to 50 bar and the maximum allowed pilot pressure is 350 bar (see *2-speed valve : 2NOR / 2NOL* on page 21).



**Note:**

When using over 50 bar pilot pressure, it is recommended to lightly throttle the pilot lines.

### 4.4.3 Working line pressure

#### WORKING PRESSURE

The working pressure is the high pressure that generates the output torque of the motor. The following values for the working pressure are in the technical data (see *Technical data* on page 10):

- PEAK PRESSURE

The value of the peak pressure is the maximum allowed value of the working pressure. Make sure the working pressure does not exceed this value under any circumstances.

- INTERMITTENT PRESSURE

The value of the intermittent pressure is a permissible value of the working pressure for a reference period of one minute (1 min). The working pressure may exceed this value for 10 % of the time during the reference period (for 6 seconds).

### MINIMUM PRESSURE

The minimum pressure is a low pressure required in the working lines, which ensures the motor stays engaged when running. The motor is engaged when the pistons of the motor stay constantly connected to the cam ring.

The required minimum pressure depends mainly on the flow rate in the working lines.

The minimum pressure is maintained with back pressure or charge pressure. Type of the hydraulic system affects the implementation.

- BACK PRESSURE

In open loop hydraulic system the minimum pressure may be done with back pressure. The back pressure is usually generated by a suitable check valve with cracking pressure.

- CHARGE PRESSURE

In closed loop hydraulic system the charge pressure is usually used as the minimum pressure.

In open loop hydraulic system the charge pressure may be done by a suitable pressure reducing valve.

When the motor is used in braking mode, value for required minimum pressure can be found in the following figure. Required minimum pressure is 50% of this value, if motor works in driving mode only. In this case pressure may not be lower than 2 bar.

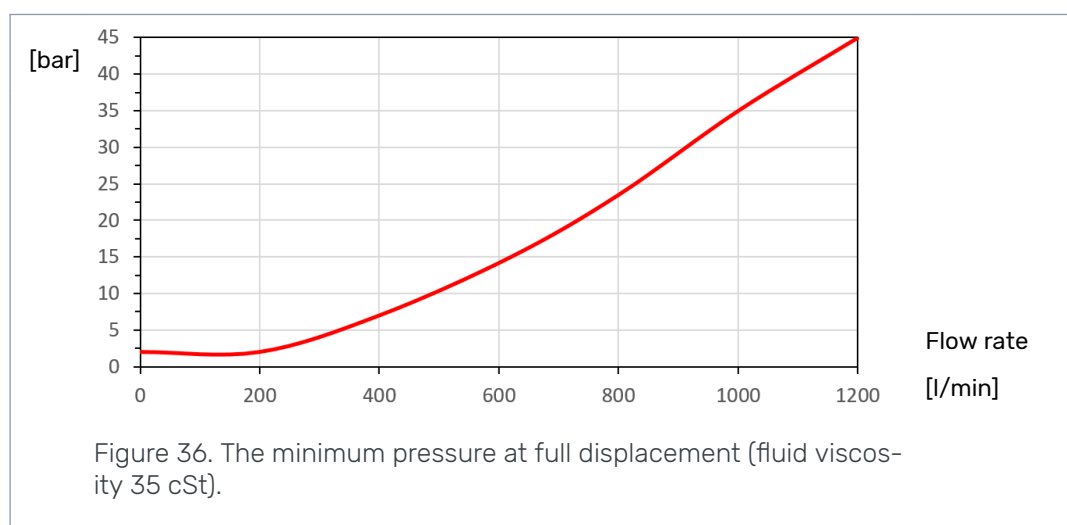

The required minimum pressure of the 2-speed motor in all applications can be found in the following figure.

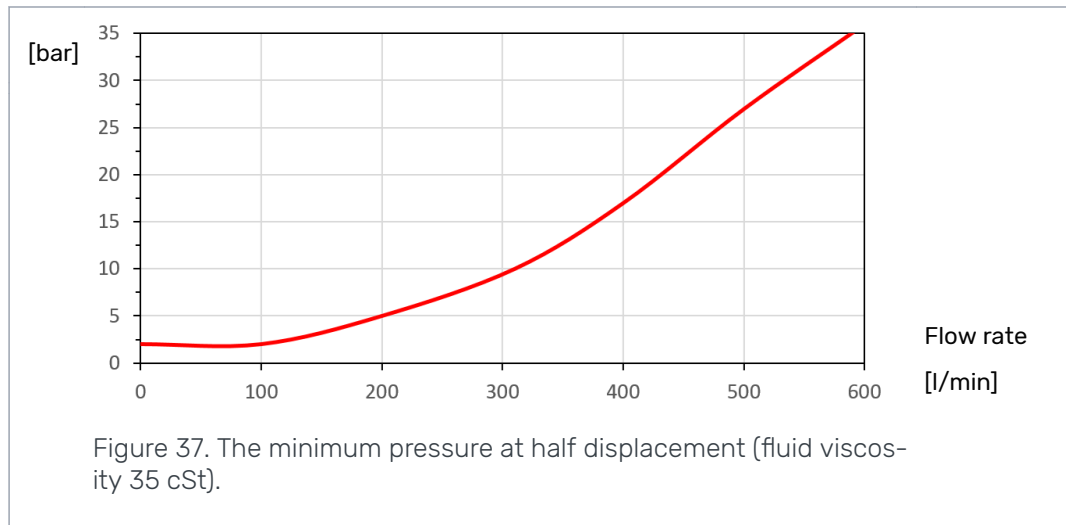

**Attention:**

Too low pressure in the working lines causes the pistons to disconnect from the cam ring when the motor is running. The effect of this is clattering noise when the pistons reconnect.

Constant use with too low working line pressure may cause premature wear or failure of the motor.



## 5 Motor Sizing

### 5.1 Performance

#### 5.1.1 Rotating speed and flow rate

Rotating speed of the motor and required flow rate may be calculated with the following equations:

<u>ROTATING SPEED</u>	
$\text{RPM} = 1000 \cdot \frac{Q}{V}$	RPM = rotating speed [rpm] V = displacement [ccm] Q = flow rate in working lines [l/min]
<u>FLOW RATE</u>	
$Q = \frac{\text{RPM} \cdot V}{1000}$	



**Note:**

Due to motor dynamics, a constant smooth operating speed of under 1 rpm may be difficult to achieve.

#### 5.1.2 Torque and power

##### Torque

The output torque of the motor is generated by the pressure difference of the working lines (pressure difference between ports A and B)

The output torque of the motor may be estimated with the following equations:

<u>MAXIMUM TORQUE</u>	
$T_{\max} = 0,01592 \cdot V \cdot \Delta p$	T = torque [Nm] V = displacement [ccm] $\Delta p$ = pressure difference [bar]

##### Power

The operating power of the motor should be determined for all operating conditions. The operating power may be calculated with the following equation:

$P = \frac{Q \cdot p_w}{600}$	P = power [kW] Q = flow rate in working lines [l/min] RPM = rotating speed [rpm] V = displacement [ccm] $p_w$ = working pressure [bar]
or	
$P = \frac{V \cdot \text{RPM} \cdot p_w}{600\,000}$	



**Note:**

Rough estimate of the operating power may be checked by dividing the available hydraulic power between the motors.

The allowed performance values can be found in the technical data (see [Technical data](#) on page 10) and performance charts (see [Performance charts](#) on page 34).

## 5.2 Performance charts

### 5.2.1 Performance curves

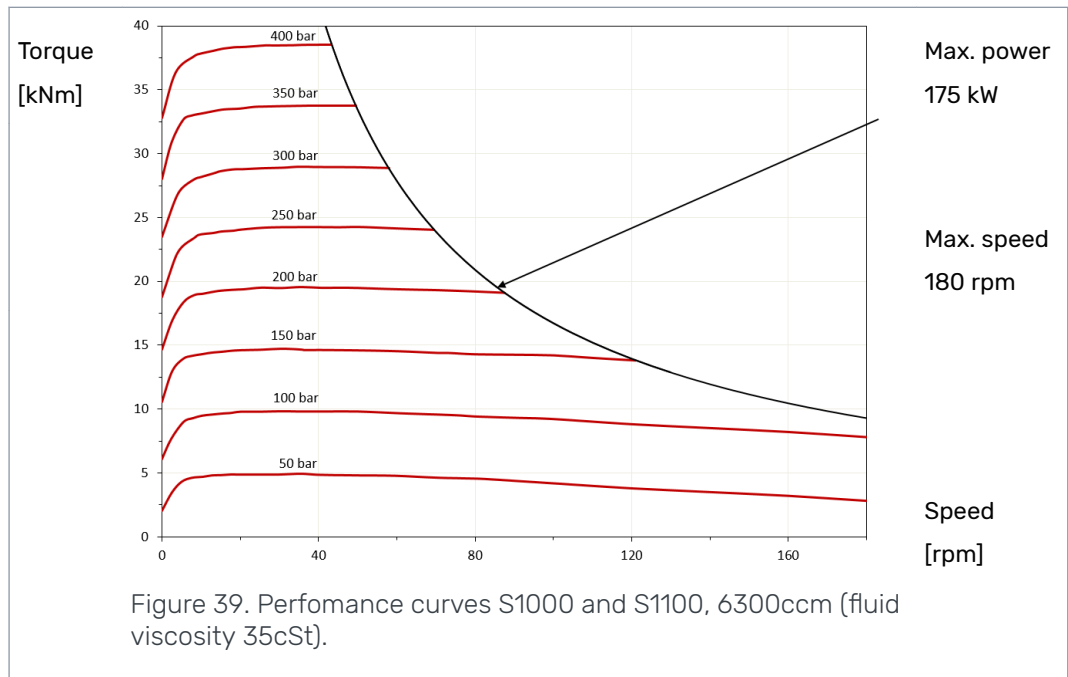
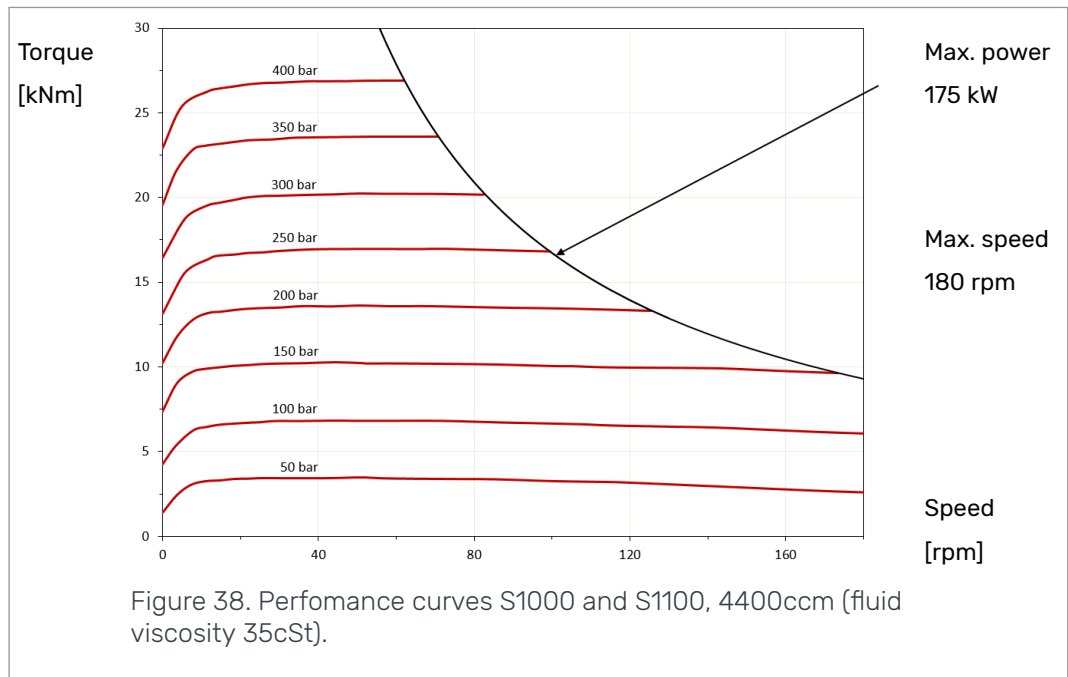

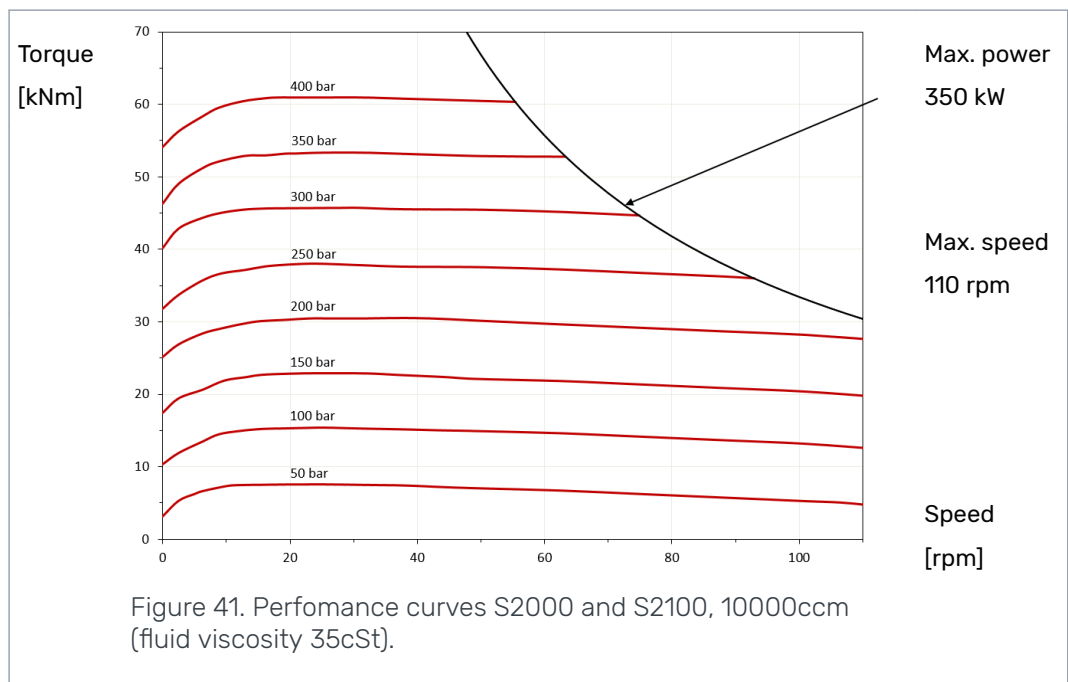
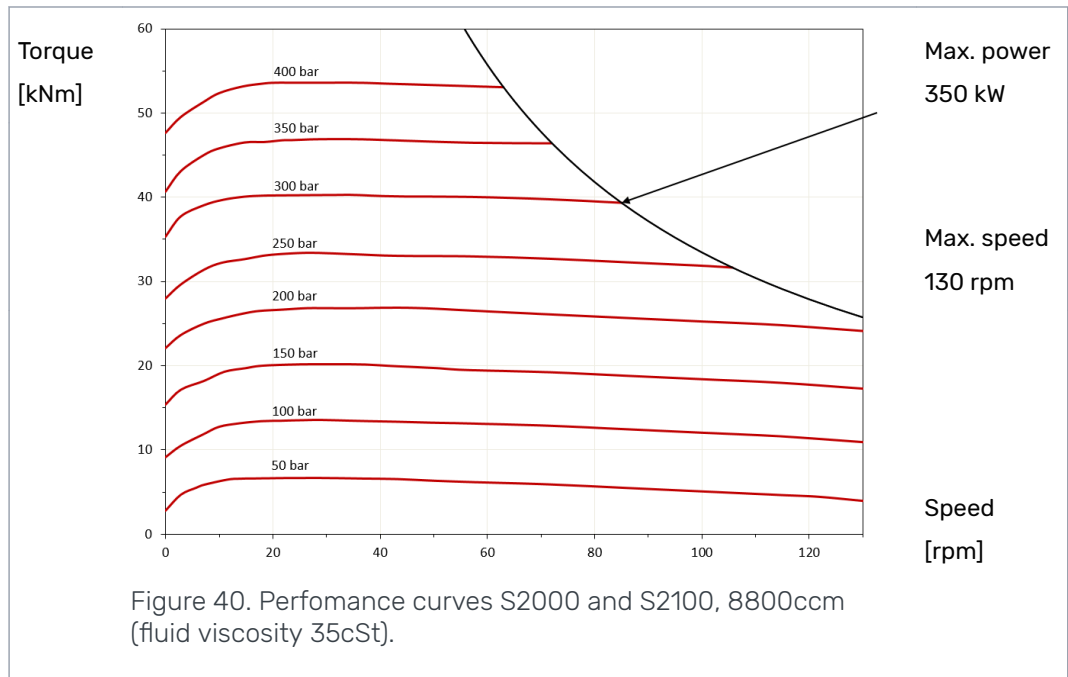

# Motor Sizing

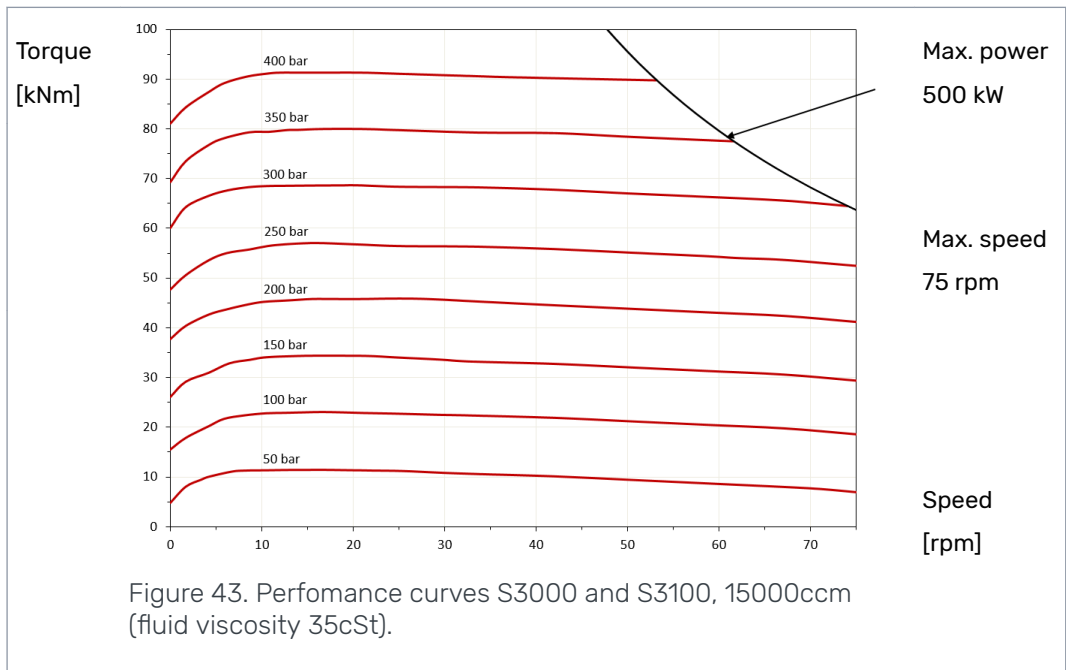
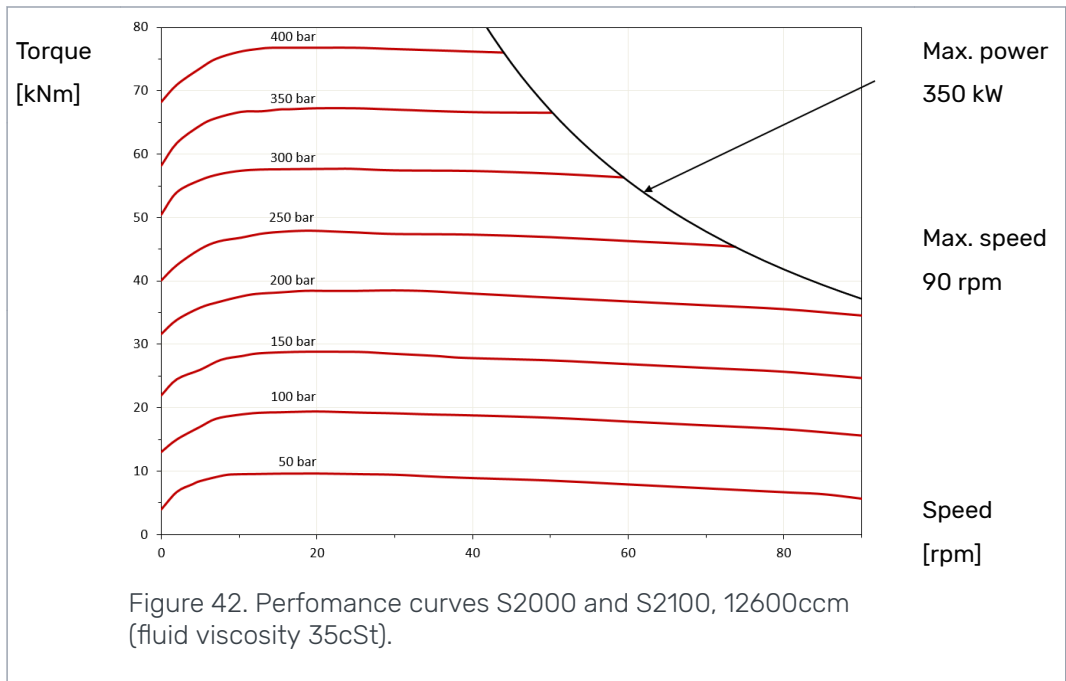

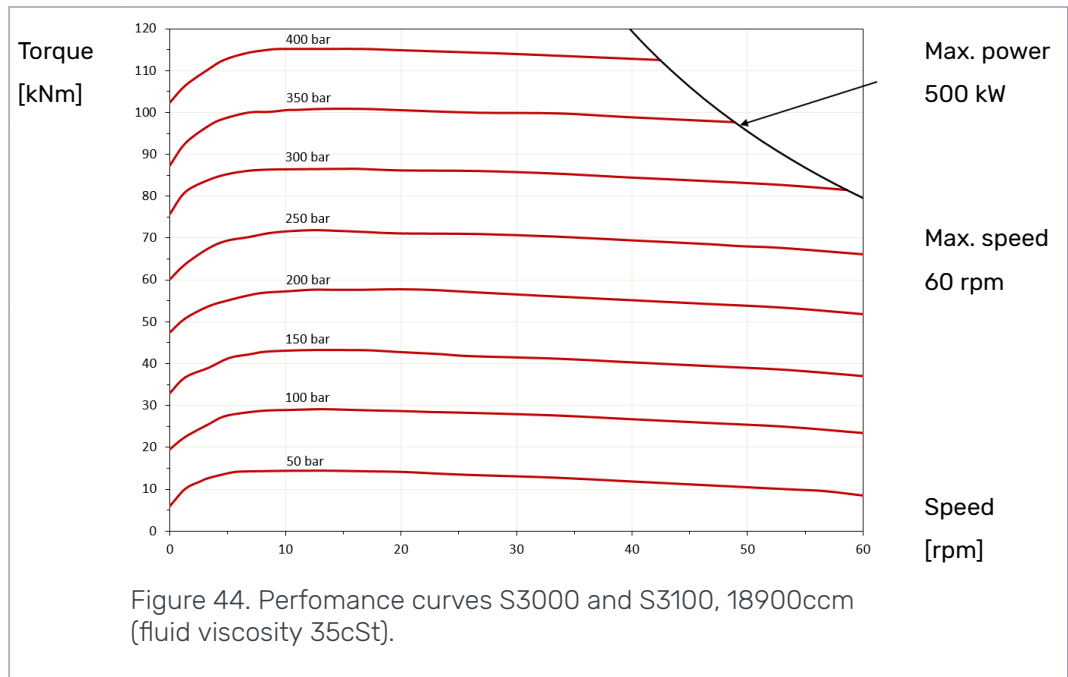

### 5.2.2

#### Pressure loss

The figures below apply to all S series motors.

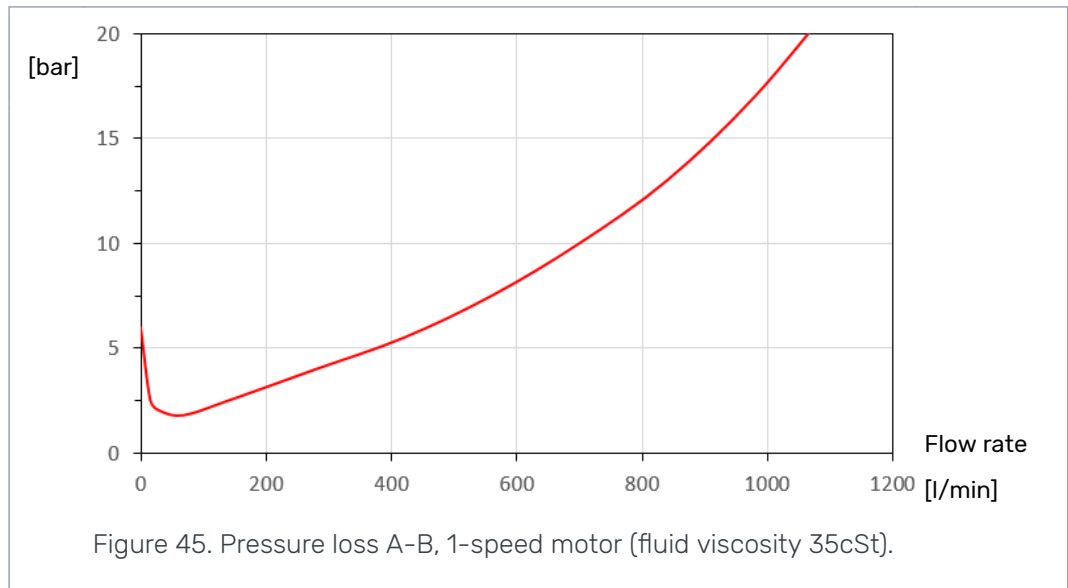

## Motor Sizing

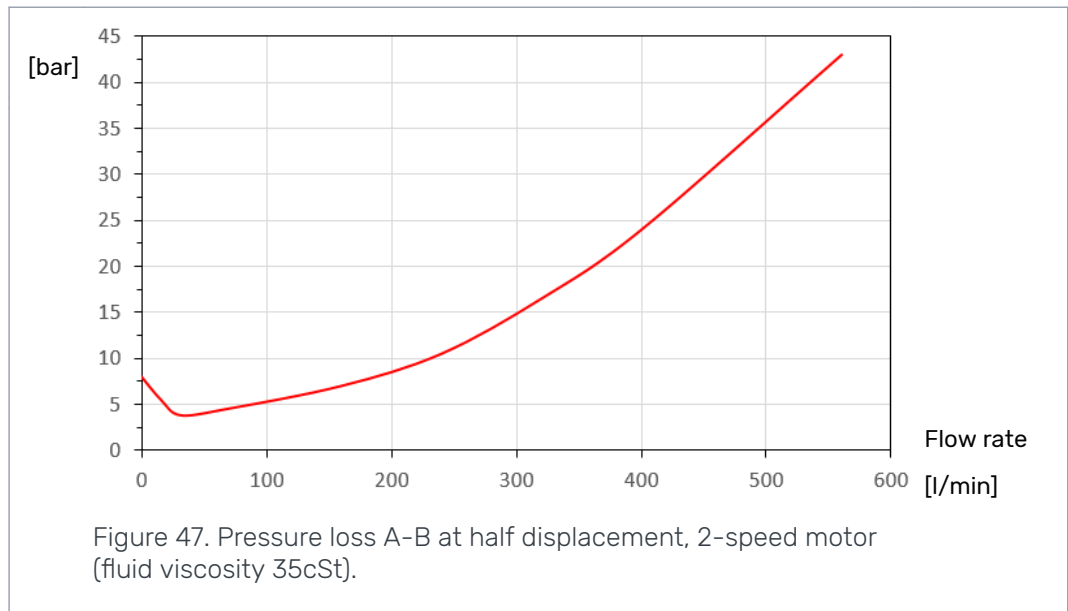
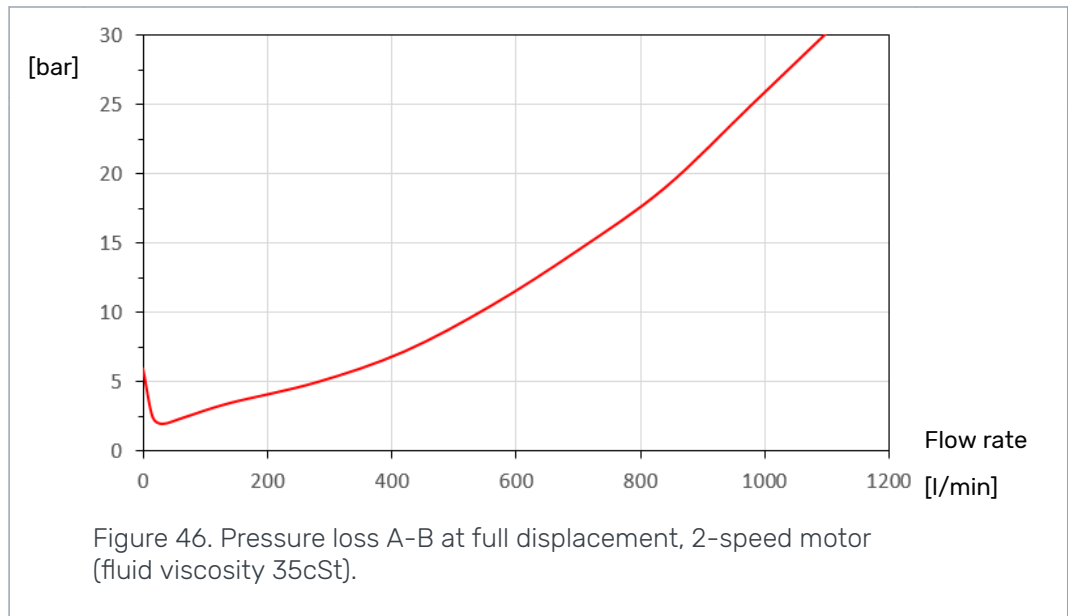

### 5.2.3 Case leakage

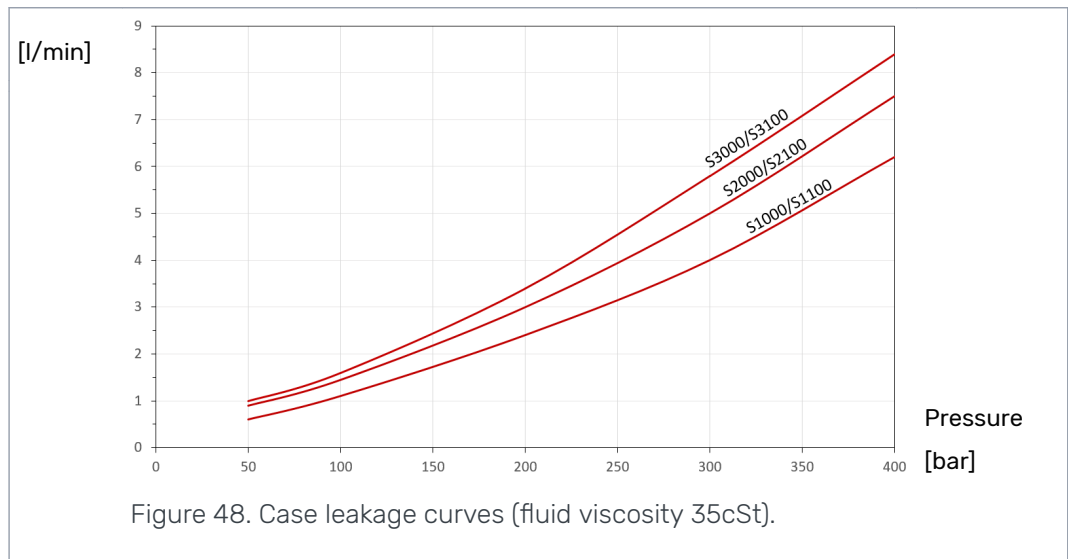

### 5.2.4 Brake torque

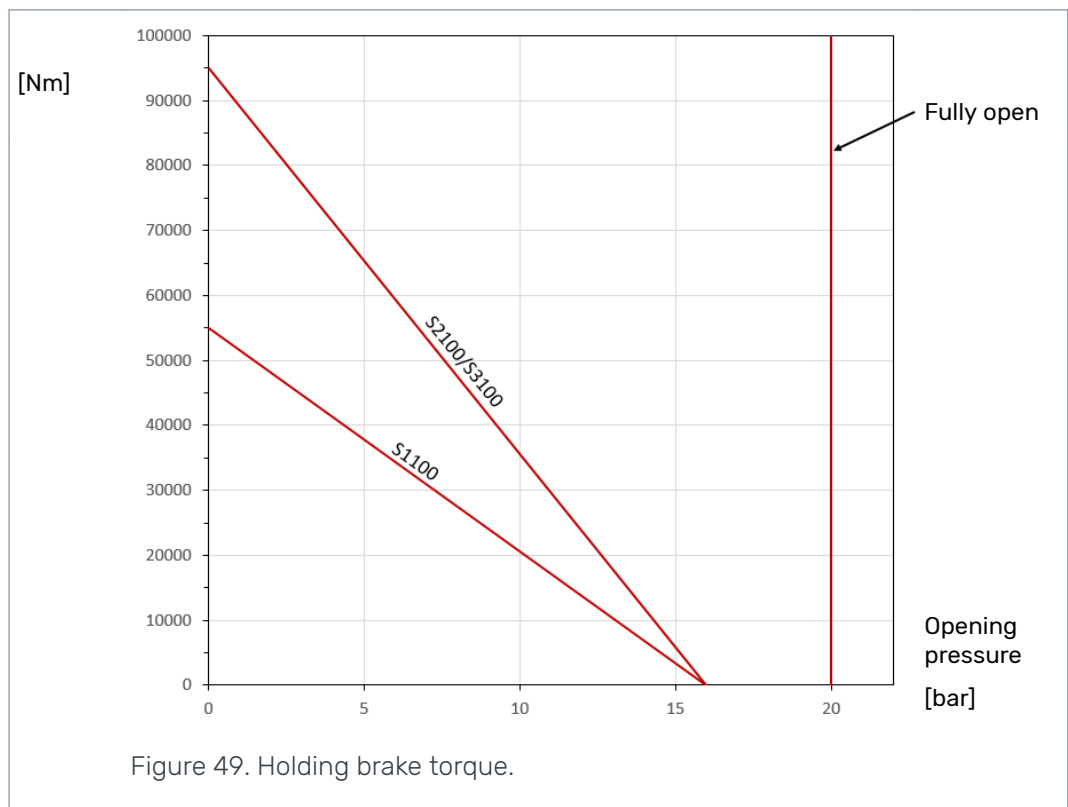

## 5.3 Service life

The service life of the motor is based on the rated life of its bearings. The bearings load curve gives the radial load value, which the motors endures for 10 million rotations with 90 % reliability.

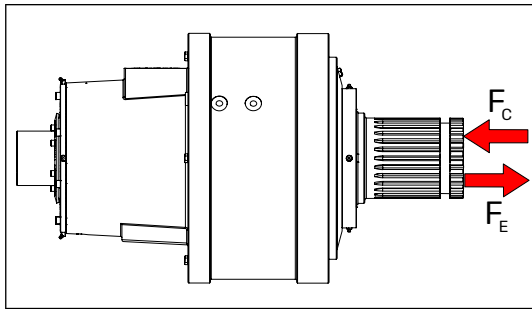
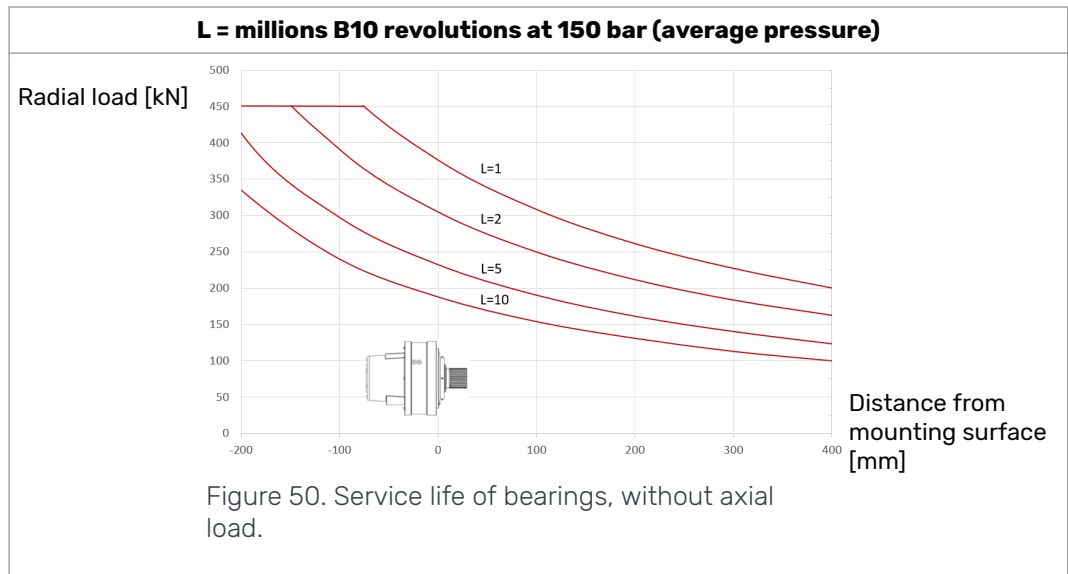

<b>Max. axial load, without radial load (work pressure 0 bar)</b>	
Compression ( $F_C$ )	225 kN
Expansion ( $F_E$ )	460 kN

The service life of the bearings and maximum axial load is influenced by the work pressure. For an accurate calculations, consult your Black Bruin application engineer.



## 6 Installation Instructions

### 6.1 Mounting the motor

The installation dimensions and tightening torques are given in the product datasheet.

Check the following things for mounting the motor:

- The counter surfaces must be clean and even.
- Make sure that the strength class (grade) of the fastening screws is sufficient.
- Make sure that the fastening screws are of suitable size and length.
- The fastening screws should be cleaned and oiled lightly before installing them.
- Use threadlocker only if necessary, removing the old threadlocker may be difficult.
- Remove any old threadlocker before mounting the motor.



**Note:**

When replacing fastening screws with new ones, renew all of the screws.

### 6.2 Flushing the hydraulic system

Prior to connecting the motor as part of the hydraulic system, the hydraulic circuit of the motor must always be flushed by circulating hydraulic fluid through a filter installed in place of the motor.

The flushing is carried out by circulating hydraulic fluid through the entire system with a minimum pressure for at least an hour.

- After flushing, renew all filters.



**Note:**

Flushing the hydraulic system should also be performed after every system modification or repair.

### 6.3 Air bleeding procedure

**For the motor**

Air bleeding procedure is carried out to fill the housing of the motor completely with hydraulic fluid. Air is removed from the housing with air bleeding screws as follows:

- Locate the topmost air bleeding screw (E/E1).
- Make sure the drain line (C2) of the motor is connected.
- Feed hydraulic fluid into the motor with low pressure throughout the procedure.
- Unscrew the air bleeding screw by half a turn and let air escape from the housing.
- Close the screw when only hydraulic fluid is pouring through it.
- Tighten the screw to a torque of  $39 \pm 3$  Nm.

**For the holding brake**

Before using the brake the air bleeding procedure must be taken care of. Air bleeding procedure is carried out to fill the housing of the brake completely with hydraulic fluid. Brake housing is separate from the motor housing so the air bleeding procedure

must be made separately for motor and brake. Air is removed from the brake with air bleeding screws as follows:

- Feed hydraulic fluid into the brake via port D throughout the air bleeding procedure.
- Locate the topmost air bleed screw of the housing (E2).
- Unscrew the air bleeding screw by half a turn and let air escape from the housing.
- Close the screw when only hydraulic fluid is pouring through it.
- Tighten the screw to a torque of  $39 \pm 3$  Nm.



**Note:**

The location of the air bleed screws can be found in [Hydraulic connections](#) on page 28.

If feed pressure is not available, fill the housing manually by pouring hydraulic fluid in the motor through the topmost opening of the housing.

## 6.4 Commissioning procedure

Ensure that the following things are in order before starting a new or replaced motor:

- The hydraulic circuit of the motor is flushed.
- Motor is installed appropriately.
- Air bleeding procedure is carried out.
- The reservoir of the hydraulic system is full.

During the initial stages of use, also take the following things into consideration:

- Do not run the motor immediately with full power. Increase the load and speed of rotation gradually.
- Observe the motor and the hydraulic system for external leaks or abnormal noises during the commissioning procedure.
- Start the motor break-in.



**Note:**

During all installation and service procedures, plug any open ports and hoses.

When filling the reservoir, add hydraulic fluid through a filter.



**Attention:**

Do not start the motor, if the air bleeding procedure has not been carried out.

Stressing an unused motor with full power may cause premature wear or failure of the motor.

## 7 Operating Instructions

### 7.1 Break-in period

The motor achieves its final properties during the first hours of use. Therefore all new and reconditioned motors should go through an initial break-in period.

Things to be considered during break-in period:

- The break-in period should last for at least first eight hours (8 h) of use.
- The power output should remain under 50 % of the maximum power capacity of the motor.
- The power output is limited by limiting the working pressure, the speed of rotation or both.
- The working pressure should be limited so, that pressure peaks which last over two seconds (2 s) remain under 75 % of the permissible values.



**Note:**

During the break-in period, the moving parts of the motor wear against each other so, that the wear of the parts sets to a stable state for the entire service life of the motor.

### 7.2 Use

Things to be considered during use of motors:

- Check the screw connections tightening torque and hydraulic connections regularly.
- Do not use pressure cleaning directly between the shaft and housing of the motor (the shaft seal area).
- Avoid situations in which the motors are completely submerged in water or mud.

### 7.3 Operating temperature

The operating temperature means the internal temperature of the motor. Take into considerations the following requirements for the operating temperature:

- For improved service life, avoid over 70 °C (158 °F) operating temperature.
- The highest permissible intermittent operating temperature is 85 °C (185 °F).
- The lowest permissible operating temperature is -35 °C (-31 °F).
- The temperature difference between the motor and the hydraulic fluid should be under 60 °C (140 °F).

The operating temperature may be measured from the hydraulic fluid returning from the motor. Take into account the temperature of hydraulic fluid returning from the drain line and from the return line (A or B).

### 7.4 Demounting the motor

Take into consideration the following things when demounting the motor for service or replacement:

- Release the pressure in the hydraulic lines and let the motor cool down.
- Disconnect all the hydraulic lines from the motor and plug all openings and hoses.
- Demount the motor and lift it away from its position.

## Operating Instructions

- Clean the outside of the motor thoroughly, but do not use any solvents.
- Protect the cleaned motor from corrosion.
- If possible, drain all the hydraulic fluid from the motor.



**Note:**

Dispose of hydraulic fluid should be done appropriately.

## 8 Special Instructions

### 8.1 Storing the motor

During short term storage of the motor, the following should be taken into consideration:

- Cover any pressure openings and open threaded holes with suitable caps.
- Protect the unpainted surfaces from dirt and moisture.
- Store the motor in a dry place with relatively stable temperature.
- The motor should not be stored in a same place as substances with aggressive corrosive nature (solvents, acids, alkalis and salts).
- The motor should not be exposed to strong magnetic fields.
- The motor should not be exposed to strong vibration.



**Note:**

For long-term storage (over 9 months) the following additional actions are recommended:

- Damages to surface paint must be repaired.
- Protect the unpainted surfaces with suitable anti-corrosion treatment.
- Fill the motor completely with hydraulic fluid.

If these instructions are followed, the motor may be stored for approximately two years. However, as storage conditions do have a significant effect, these times should only be considered as guide values.

# No POWER like it.



## **Black Bruin Inc.**

+358 20 755 0755  
P.O. Box 633, FI-40101 JYVÄSKYLÄ, FINLAND

[www.blackbruin.com](http://www.blackbruin.com)  
[info@blackbruin.com](mailto:info@blackbruin.com)

All the information contained in this publication is based on the latest information available at the time of publication. Black Bruin Inc. reserves the right to make changes without prior notice.