

ez-Wheel **ezW10R** can electrically power :

- Delivery carts
- Personal carriers
- Urban pedestrian vehicles
- ...

#### Immediate fitting

The self-propelled ez-Wheel can be fitted immediately on any vehicle chassis or mobile equipment. No electrical connection is needed, since the wheel is self-powered by the built-in battery and driven by wireless communication.

#### High torque

With peak torque of 55 Nm, the electric motor provides exceptional clearance capability and equipment fitted with the motor can carry loads of several hundred kg.

#### Compact and robust

All electric propulsion components are built into the hub itself, freeing the whole chassis from batteries or electric switch boxes. The aluminium hub fairing protects all components from knocks and splashing.

#### Quiet

The motor technology and mechanical transmission are designed to run extremely quietly and vehicles fitted with them do not cause any noise pollution.

#### Maintenance free

All components are designed for a maintenance-free lifespan of more than 5 years. The very long-life batteries used in the wheel can sustain thousands of use and recharging cycles.



#### Main specifications

Format/Diameter	10" / 400 mm
Type of tyre	Road 100-80-10
Speed	0 to 18 km/h
Nominal power/Peak	250 W / 1kW
Battery capacity	240 Wh
Torque peak	55 Nm
Options	Disc brake holder

#### Environmentally responsible

The approach to ez-Wheel product design is to minimize environmental impact. Collection and recycling are organized for products reaching the end of their lifecycle. Contact your dealer for more information.

## High-Tech built-in solution

All the components necessary for traction are built into the wheel: the electric motor, high energy, very long life batteries, a power controller ensuring optimum motor control and battery management and a wireless interface.

### Motor specification

Technology	Brushless (BLDC PM)
Maximum speed	240 rpm (18km/h)
Nominal power	250 W (S1 at 10 km/h)
Peak power	1 kW
Peak torque	55 Nm

### Battery

Electrochemistry	Ni-MH
Energy	240 Wh
Lifespan	>5 years
Recharging time	3 hours (for 90%)

### Interface

Technology	Wireless (LR WPAN)
Frequency	2.4 GHz
Protocol	Based on IEEE 802.15.4

## Multi-purpose

The wheel can be used inside or outside, over a wide range of temperatures. The components – including the battery – do not need any inspection or maintenance over the product's whole lifespan of more than 5 years.

The aluminium casing enables the wheel to bear a load of up to 300 kg (150 kg per tyre). The robust assembly can withstand the stresses of knocks and severe vibration.

### Conditions of use

Temperature	-20 to +60°C
IP index	IP65
Maintenance period	>5 years

### Weight

Total weight wheel	14.5 kg
Maximum load	150 kg per wheel / tyre

## Warranty

ez-Wheel products are guaranteed 1 year from the date of purchase. Consult the general conditions of sale for more information.

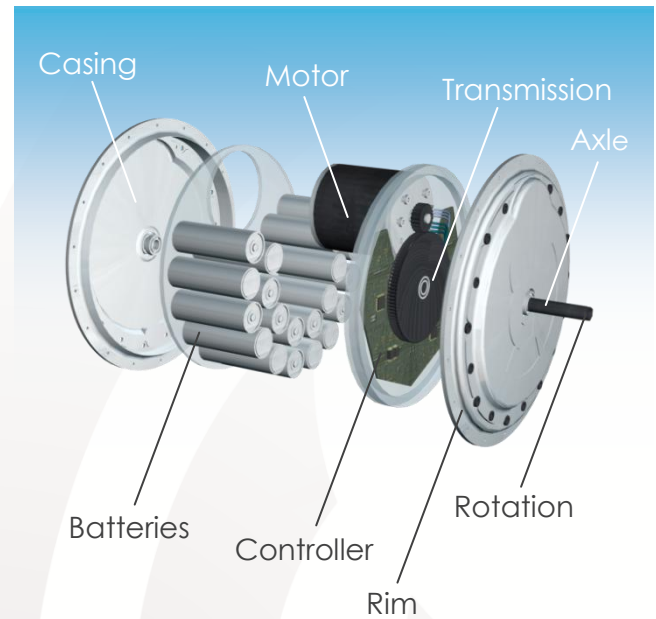

## Standard

The standardized dimensions and mechanical interface make it simple and quick to fit the product. The bored axle of the wheel is mounted on a 16 mm shaft just like a free wheel and the rotation stop consists of a locking collar at the end of the axle.

The hub forms a standardized rim, taking a 100-80-10 tyre fitted with a 3.5-10 inner tube. The wheel is delivered with a "road" tyre.

### Functional dimensions

Outer diameter	400 mm
Bore diameter	16 mm
Width of tyre	103 mm
Width of wheel	131 mm
Width of axle	141 mm

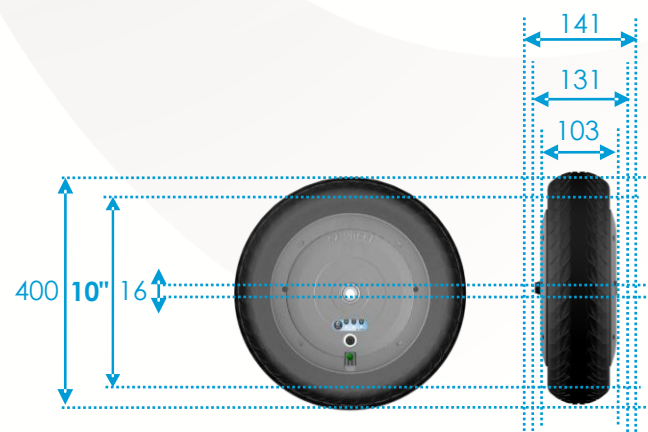

Design blueprint available on the website [www.ez-wheel.com](http://www.ez-wheel.com)